

# VSI OpenVMS

# VSI ACMS for OpenVMS Remote Systems Management Guide

Document Number: DO-DACMMG-01A

Publication Date: October 2019

**Revision Update Information:** This is a new manual.

**Operating System and Version:** VSI OpenVMS Integrity Version 8.4-1H1  
VSI OpenVMS Alpha Version 8.4-2L1

**Software Version:** ACMS for OpenVMS Version 5.3-2

---

## VSI ACMS for OpenVMSRemote Systems Management Guide:



---

Copyright © 2019 VMS Software, Inc., (VSI), Bolton Massachusetts, USA

### Legal Notice

Confidential computer software. Valid license from VSI required for possession, use or copying. Consistent with FAR 12.211 and 12.212, Commercial Computer Software, Computer Software Documentation, and Technical Data for Commercial Items are licensed to the U.S. Government under vendor's standard commercial license.

The information contained herein is subject to change without notice. The only warranties for VSI products and services are set forth in the express warranty statements accompanying such products and services. Nothing herein should be construed as constituting an additional warranty. VSI shall not be liable for technical or editorial errors or omissions contained herein.

HPE, HPE Integrity, HPE Alpha, and HPE Proliant are trademarks or registered trademarks of Hewlett Packard Enterprise.

The VSI OpenVMS documentation set is available on DVD.

<b>Preface .....</b>	<b>ix</b>
1. About this manual .....	ix
2. Document Structure .....	ix
3. Related Documents .....	x
4. VSI Encourages Your Comments .....	xi
5. Conventions .....	xi

## Part I. Introduction

<b>Chapter 1. Overview of Remote Management .....</b>	<b>3</b>
1.1. Architecture and Implementation .....	3
1.2. Remote Management Capabilities .....	4
<b>Chapter 2. Getting Started with the ACMS Remote Manager .....</b>	<b>5</b>
2.1. Running the ACMS Remote Manager .....	5
2.1.1. Server Node Setup .....	5
2.1.1.1. Verify Portmapper (RPC) Setup .....	6
2.1.1.2. Run the ACMS Postinstallation Procedure .....	7
2.1.1.3. Define Process Logicals and Symbols .....	7
2.1.1.4. Prepare the ACMS Environment .....	7
2.1.1.5. Start the ACMS Remote Manager .....	7
2.1.2. Client Node Setup .....	8
2.1.2.1. Run ACMS_POST_INSTALL.COM .....	8
2.1.2.2. Copy Files and Define Symbols .....	9
2.1.3. Communicate with the Remote Manager .....	9
2.2. TCP/IP Setup .....	10
2.2.1. Set Up the Portmapper (RPC) .....	11
2.2.1.1. Determine the Current Portmapper Configuration .....	11
2.2.1.2. Remove the Existing Portmapper Configuration .....	11
2.2.1.3. Configure the Portmapper .....	12
2.2.2. Set Up SNMP .....	13
2.2.2.1. Determine the Current SNMP Configuration .....	13
2.2.2.2. Remove the Existing SNMP Configuration .....	14
2.2.2.3. Configure SNMP .....	14
2.2.2.4. Test SNMP .....	16
2.3. Remote Manager Setup .....	16
2.3.1. Run the Postinstallation Procedure .....	17
2.3.2. Define Process Logicals and Symbols .....	18
2.3.3. Review and Update the Configuration File .....	19
2.3.4. Start the Remote Manager .....	19
2.3.5. Communicate with the Remote Manager .....	20
2.3.5.1. Using ACMSMGR and Logging In Explicitly .....	20
2.3.5.2. Using ACMSMGR and a Proxy Account .....	20
2.4. Troubleshooting the ACMS Remote Manager Startup .....	21
2.4.1. Problems Starting ACMS .....	21
2.4.2. Problems Starting the ACMS Remote Manager .....	22
2.4.2.1. ACMS\$MGMT_SERVER.OUT Messages .....	22
2.4.2.2. Remote Manager Log Entries .....	23
2.4.3. Problems with the ACMSMGR Utility .....	25
2.4.3.1. ACMSMGMT-W-NOCLNT_ATTACH Messages .....	25
2.4.3.2. ACMSMGR Hangs .....	26
<b>Chapter 3. Using the Remote Manager to Manage ACMS .....</b>	<b>27</b>

3.1. Overview of the Remote Manager Web Agent .....	27
3.2. Remote Manager Web Agent Setup .....	27
3.2.1. Install the Remote Manager Web Agent Software .....	28
3.2.2. Install the VSI Management Agents for OpenVMS Software .....	30
3.2.3. Assign Additional Rights Identifiers .....	30
3.2.4. Start the Remote Manager Web Agent Process .....	31
3.2.5. Enable Access to Remote Manager Hosts .....	31
3.2.6. Stop the Remote Manager Web Agent .....	31
3.3. Using the Remote Manager Web Agent .....	32
3.3.1. Accessing the ACMS Remote Management Web Page .....	32
3.3.2. Conventions .....	33
3.3.3. Customizing the Display .....	33
3.3.4. Selecting the Remote Manager Host .....	34
3.4. Issuing Remote Manager Commands .....	34
3.4.1. Using Show Commands .....	34
3.4.2. Using Set Commands .....	35
3.4.3. Using Start and Stop Commands .....	36
3.4.4. Using Add and Delete Commands .....	36
3.5. Troubleshooting the Remote Manager Web Agent .....	37
3.5.1. Reporting Problems .....	38
<b>Chapter 4. Managing the Remote Manager .....</b>	<b>39</b>
4.1. Overview .....	39
4.2. Configuring Remote Manager Startup .....	39
4.2.1. How to Run the ACMSCFG Utility .....	40
4.2.2. Displaying Current Values .....	40
4.2.3. Changing Values .....	41
4.3. Starting and Stopping the Remote Manager .....	42
4.3.1. Remote Manager Startup .....	42
4.3.2. Remote Manager Shutdown .....	43
4.4. Logging In to the Remote Manager .....	43
4.4.1. Authentication .....	43
4.4.1.1. Logging In .....	44
4.4.1.2. Proxy Accounts .....	44
4.4.2. Authorization .....	45
4.4.2.1. Read Access .....	45
4.4.2.2. Write Access .....	45
4.4.2.3. Operate Access .....	45
4.5. Starting and Stopping Interfaces .....	46
4.5.1. Using ACMSCFG to Enable or Disable Interfaces .....	46
4.5.2. Using ACMSMGR to Start or Stop Interfaces .....	46
4.6. Modifying Management Parameters .....	47
4.6.1. Using ACMSCFG to Modify Management Parameters .....	47
4.6.2. Using ACMSMGR to Modify Management Parameters .....	48
4.7. Managing Log Files .....	48
4.7.1. Setting Audit Levels .....	48
4.7.2. Displaying Audit Messages .....	50
4.7.3. Resetting the Audit Log .....	50
<b>Chapter 5. Using the Remote Manager to Manage ACMS .....</b>	<b>51</b>
5.1. Managing Data Collection .....	51
5.1.1. Entities, Classes, Names, and Collections .....	52
5.1.2. Starting and Stopping Collections .....	54

5.1.2.1. Using ACMSCFG to Start or Stop Collections .....	54
5.1.2.2. Using ACMSMGR to Start or Stop Collections .....	55
5.1.2.3. Using SNMP to Start or Stop Collections .....	56
5.2. Displaying Collected Data .....	56
5.2.1. Using ACMSMGR to Display Collected Data .....	56
5.3. Managing ACMS Using the Remote Manager .....	56
5.3.1. Types of Variables .....	57
5.3.1.1. Stored Variables .....	57
5.3.1.2. Active Variables .....	57
5.3.2. How the Remote Manager Makes Changes .....	58
5.3.3. Using ACMSMGR to Modify the ACMS Run-Time System .....	58
5.3.4. Using SNMP to Modify the ACMS Run-Time System .....	59
5.3.4.1. Starting and Stopping Processes Using SNMP .....	60
5.3.4.2. Adding and Deleting Rows Using SNMP .....	60
5.3.4.3. Replacing Application Procedure Servers Using SNMP .....	60
5.3.5. Using ONC RPC to Modify the ACMS Run-Time System .....	60
<b>Chapter 6. Management Programming Using ONC RPC .....</b>	<b>63</b>
6.1. ONC RPC Overview .....	63
6.2. API Overview .....	65
6.3. Initialization and Security .....	65
6.3.1. Initialization Example .....	66
6.4. Get Procedures .....	67
6.4.1. Get Example .....	67
6.5. List Procedures .....	68
6.5.1. Linked List Example .....	69
6.6. Set Procedures .....	72
6.6.1. Set Example .....	73
6.7. Delete Procedures .....	74
6.7.1. Delete Example .....	75
6.8. Add Procedures .....	75
6.8.1. Add Example .....	76
6.9. Start, Stop, and Replace Procedures .....	77
6.9.1. Start Example .....	78
<b>Chapter 7. Management Programming Using SNMP .....</b>	<b>81</b>
7.1. SNMP Overview .....	81
7.2. SNMP Security .....	82
7.3. Initializing the SNMP Interface .....	82
7.4. SNMP Tables .....	83
7.4.1. Data Type Mapping .....	84
7.4.2. Single-Row Tables .....	84
7.4.3. Static Tables .....	84
7.4.4. Dynamic Tables .....	86
7.4.5. Servers and Task Groups .....	86
7.5. SNMP GET Operations .....	87
7.6. SNMP SET Operations .....	87
7.7. Using SNMP to Start and Stop ACMS Entities .....	88
7.8. SNMP Traps .....	88
7.8.1. EXISTS Traps .....	89
7.8.2. EVENT_SEVERITY Traps .....	90
7.9. SNMP Debug Tracing .....	90
7.9.1. Starting SNMP Debug Tracing .....	91

7.9.2. Stopping SNMP Debug Tracing .....	91
7.10. Remote Manager eSNMP Return Codes .....	91

## Part II. Reference Information

<b>Chapter 8. Management APIs .....</b>	<b>95</b>
8.1. Common RPC Fields .....	95
8.1.1. Collection Classes .....	95
8.1.2. Interface Types .....	95
8.1.3. Enable States .....	95
8.1.4. Entity Types .....	96
8.1.5. Facility Types .....	96
8.1.6. Running States .....	97
8.1.7. Severity Codes .....	97
8.1.8. Trap Parameters .....	97
8.2. Thread-Safe and Non-Thread Safe Clients .....	98
8.3. ACMSMGMT_ADD_COLLECTION_2 .....	98
<b>Chapter 9. Remote Manager Reference Tables .....</b>	<b>245</b>
9.1. Data Types .....	245
9.2. ACC Table .....	246
9.2.1. Field Descriptions .....	248
9.3. Agent Table .....	254
9.3.1. Field Descriptions .....	257
9.4. Collection Table .....	261
9.4.1. Field Descriptions .....	262
9.5. CP Table .....	263
9.5.1. Field Descriptions .....	265
9.6. EXC Table .....	268
9.6.1. Field Descriptions .....	271
9.7. Interfaces Table .....	277
9.7.1. Field Descriptions .....	277
9.8. Manager Status Table .....	278
9.8.1. Field Descriptions .....	279
9.9. Parameter Table .....	279
9.9.1. Field Descriptions .....	281
9.10. QTI Table .....	284
9.10.1. Field Descriptions .....	286
9.11. Server Table .....	289
9.11.1. Field Descriptions .....	289
9.12. Task Group Table .....	291
9.12.1. Field Descriptions .....	292
9.13. Trap Table .....	293
9.13.1. Field Descriptions .....	294
9.14. Valid Trap Minimums and Maximums .....	296
9.14.1. Field Descriptions .....	296
9.14.2. Valid Trap Minimums and Maximums .....	298
9.14.3. SNMP Trap Format .....	300
9.15. TSC Table .....	301
9.15.1. Field Descriptions .....	302
9.16. Users Table .....	305
9.16.1. Field Descriptions .....	306

<b>Chapter 10. ACMSCFG Commands</b> .....	<b>309</b>
10.1. ACMSCFG Overview .....	309
10.1.1. Command Format .....	309
10.1.2. Command Objects and Qualifiers .....	309
10.2. ACMSCFG ADD COLLECTION .....	311
10.3. ACMSCFG ADD TRAP .....	314
10.4. ACMSCFG DELETE COLLECTION .....	316
10.5. ACMSCFG DELETE TRAP .....	317
10.6. ACMSCFG SET COLLECTION .....	319
<b>Chapter 11. ACMSMGR Commands</b> .....	<b>333</b>
11.1. ACMSMGR Overview .....	333
11.1.1. Command Format .....	333
11.1.2. Command Objects and Qualifiers .....	333
11.2. ACMSMGR ADD COLLECTION .....	337
11.3. ACMSMGR ADD FILTER .....	341
11.4. ACMSMGR ADD TRAP .....	343
11.5. ACMSMGR DELETE COLLECTION .....	345
11.6. ACMSMGR DELETE FILTER .....	347
11.7. ACMSMGR DELETE TRAP .....	349
11.8. ....	351
11.9. ACMSMGR LOGIN .....	351
11.10. ACMSMGR LOGOUT .....	353
11.11. ACMSMGR REPLACE SERVER .....	355
11.12. ACMSMGR RESET ERROR .....	356
11.13. ACMSMGR RESET LOG .....	357
11.14. ACMSMGR SAVE FILTER .....	359
11.15. ACMSMGR SET ACC .....	360
11.16. ACMSMGR SET AGENT .....	365
11.17. ACMSMGR SET COLLECTION .....	367
11.18. ACMSMGR SET CP .....	371
11.19. ACMSMGR SET EXC .....	373
11.20. ACMSMGR SET INTERFACE .....	376
11.21. ACMSMGR SET PARAMETER .....	378
11.22. ACMSMGR SET QTI .....	381
11.23. ACMSMGR SET SERVER .....	384
11.24. ACMSMGR SET TRAP .....	387
11.25. ACMSMGR SET TSC .....	389
11.26. ACMSMGR SHOW ACC .....	393
11.27. ACMSMGR SHOW AGENT .....	398
11.28. ACMSMGR SHOW COLLECTION .....	402
11.29. ACMSMGR SHOW CP .....	404
11.30. ACMSMGR SHOW ERROR .....	407
11.31. ACMSMGR SHOW EXC .....	410
11.32. ACMSMGR SHOW FILTER .....	412
11.33. ACMSMGR SHOW GROUP .....	414
11.34. ACMSMGR SHOW INTERFACE .....	417
11.35. ACMSMGR SHOW LOG .....	418
11.36. ACMSMGR SHOW MANAGER .....	424
11.37. ACMSMGR SHOW PARAMETER .....	425
11.38. ACMSMGR SHOW PROCESS .....	428
11.39. ACMSMGR SHOW QTI .....	431
11.40. ACMSMGR SHOW SERVER .....	434

11.41. ACMSMGR SHOW TRAP .....	436
11.42. ACMSMGR SHOW TSC .....	438
11.43. ACMSMGR SHOW USER .....	442
11.44. ACMSMGR SHOW VERSION .....	445
11.45. ACMSMGR START EXC .....	447
11.46. ACMSMGR START QTI .....	448
11.47. ACMSMGR START SYSTEM .....	449
11.48. ACMSMGR START TERMINALS .....	451
11.49. ACMSMGR START TRACE_MONITOR .....	452
11.50. ACMSMGR STOP EXC .....	454
11.51. ACMSMGR STOP MANAGER .....	455
11.52. ACMSMGR STOP QTI .....	456
11.53. ACMSMGR STOP SYSTEM .....	458
11.54. ACMSMGR STOP TERMINALS .....	459
11.55. ACMSMGR STOP TRACE_MONITOR .....	460
<b>Chapter 12. ACMSSNAP Commands .....</b>	<b>463</b>
12.1. ACMSSNAP Overview .....	463
12.1.1. Command Format .....	463
12.1.2. Command Objects and Qualifiers .....	463
12.2. ACMSSNAP CLOSE Command .....	464
12.3. ACMSSNAP EXIT Command .....	465
12.4. ACMSSNAP HELP Command .....	466
12.5. ACMSSNAP NEXT Command .....	466
12.6. ACMSSNAP OPEN Command .....	467
12.7. ACMSSNAP PREV Command .....	469
12.8. ACMSSNAP QUIT Command .....	470
12.9. ACMSSNAP RESET Command .....	471
12.10. ACMSSNAP SHOW Command .....	472
12.11. ACMSSNAP TRACE Command .....	475
<b>Appendix A. Remote Manager Logical Names .....</b>	<b>477</b>
A.1. Remote Manager Server .....	477
A.2. Remote Manager Client (ACMSMGR Utility) .....	477
<b>Appendix B. RPC Procedures and Corresponding Rights Identifiers .....</b>	<b>479</b>
<b>Appendix C. RPC Procedures and Corresponding Rights Identifiers .....</b>	<b>481</b>
C.1. Server Messages .....	481
C.2. ACMSMGR Messages .....	490
C.3. ACMSCFG Messages .....	495
C.4. ACMSSNAP Messages .....	501
<b>Index .....</b>	<b>503</b>



# Preface



## 1. About this manual

This manual explains how to use the Remote Manager to manage *Compaq ACMS for OpenVMS* (ACMS) software systems remotely. The manual describes the features of the Remote Manager, which is based on a client/server architecture, how to use the features, and how to manage the Remote Manager. It also provides reference information for the utilities and commands you use in working with the Remote Manager.

## 2. Document Structure

This manual contains ten chapters and three appendixes. The chapters are grouped into two parts. The first part contains chapters concerning the use of remote management features of ACMS. The second part contains chapters concerning reference information for the remote management of ACMS systems. The appendixes follow Part II.

<i>Part I</i>	<i>Introduction</i>
Chapter 1	Introduces the architecture, implementation, and capabilities of ACMS remote management.
Chapter 2	Describes how to get started using the Remote Manager including preparation and startup of the server and client nodes; setting up TCP/IP; setting up SNMP; and troubleshooting the Remote Manager.
Chapter 4	Describes how to manage the ACMS Remote Manager including configuring startup; starting, stopping, and logging in to the Remote Manager; starting and stopping interfaces; and modifying management parameters and log files.
Chapter 5	Describes how to use the Remote Manager to manage ACMS, including managing data collection, displaying collected data, and modifying ACMS systems.
Chapter 6	Describes how programmers can use the Open Network Computing (ONC ) remote procedure call (RPC ) interface to the ACMS Remote Manager to develop their own programs for managing ACMS systems.
Chapter 7	Describes how programmers can use the Simple Network Management Protocol (SNMP ) interface to the ACMS Remote Manager to develop their own programs for managing ACMS systems.
<i>Part II</i>	<i>Reference Information</i>

Chapter 8	Provides reference information about the ACMS remote management APIs, which are procedures that are intended to be called from ONC RPC clients.
Chapter 9	Provides reference information about data types and tables for the ACMS Remote Manager.
Chapter 10	Provides reference information about the commands of the ACMSCFG utility for performing operations on the Remote Manager configuration file.
Chapter 11	Provides reference information about the commands of the ACMSMGR utility for performing operations on running ACMS systems.
<i>Appendices</i>	
Appendix A	Contains information about the logical names used by the Remote Manager server and the Remote Manager client (ACMSMGR utility).
Appendix B	Contains information providing cross-references of remote procedure call (RPC) procedures to rights identifiers.
Chapter 12	Contains a listing of information about Simple Network Management Protocol (SNMP) object identifiers (OIDs) for ACMS management information base (MIB) fields.

### 3. Related Documents

The following table lists the books in the VSI ACMS for OpenVMS documentation set.

**Table 1. Related documents**

<b>Title</b>	<b>Description</b>
<i>VSI ACMS Version 5.0 for OpenVMS Release Notes</i>	Information about the latest release of the software. Available online only.
<i>VSI ACMS Version 5.0 for OpenVMS Installation Guide</i>	Description of installation requirements, the installation procedure, and postinstallation tasks.
<i>VSI ACMS for OpenVMS Getting Started</i>	Overview of ACMS software and documentation. Tutorial for developing a simple ACMS application. Description of the AVERTZ sample application.
<i>VSI ACMS for OpenVMS Concepts and Design Guidelines</i>	Description of how to design an ACMS application.
<i>VSI ACMS for OpenVMS Writing Applications</i>	Description of how to write task, task group, application, and menu definitions using the Application Definition Utility. Description of how to write and migrate ACMS applications on an OpenVMS Alpha system.

Title	Description
<i>VSI ACMS for OpenVMS Writing Server Procedures</i>	Description of how to write programs to use with tasks and how to debug tasks and programs. Description of how ACMS works with the APPC/ LU6.2 programming interface to communicate with IBM CICS applications. Description of how ACMS works with third-party database managers, with ORACLE used as an example.
<i>VSI ACMS for OpenVMS Systems Interface Programming</i>	Description of using Systems Interface (SI) Services to submit tasks to an ACMS system.
<i>VSI ACMS for OpenVMS ADU Reference Manual</i>	Reference information about the ADU commands, phrases, and clauses.
<i>VSI ACMS for OpenVMS Quick Reference</i>	List of ACMS syntax with brief descriptions.
<i>VSI ACMS for OpenVMS Managing Applications</i>	Description of authorizing, running, and managing ACMS applications, and controlling the ACMS system.
<i>VSI ACMS for OpenVMS Remote Systems Management Guide</i>	Description of the features of the Remote Manager for managing ACMS systems, how to use the features, and how to manage the Remote Manager.
Online help	Online help about ACMS and its utilities.

For additional information on the compatibility of other software products with this version of ACMS, refer to the *Compaq ACMS for OpenVMS Software Product Description* (SPD 25.50.xx).

For additional information about the Open Systems Software Group (OSSG) products and services, access the following OpenVMS World Wide Web address:

tbs

## 4. VSI Encourages Your Comments

You may send comments or suggestions regarding this manual or any VSI document by sending electronic mail to the following Internet address: <docinfo@vmssoftware.com>. Users who have OpenVMS support contracts through VSI can contact <support@vmssoftware.com> for help with this product. Users who have OpenVMS support contracts through HPE should contact their HPE Support channel for assistance.

## 5. Conventions

VMScluster systems are now referred to as OpenVMS Cluster systems. Unless otherwise specified, references to OpenVMS Cluster systems or clusters in this document are synonymous with VMScluster systems.

The contents of the display examples for some utility commands described in this manual may differ slightly from the actual output provided by these commands on your system. However, when the behavior of a command differs significantly between OpenVMS Alpha and Integrity servers, that behavior is described in text and rendered, as appropriate, in separate examples.

In this manual, every use of DECwindows and DECwindows Motif refers to DECwindows Motif for OpenVMS software.

The following conventions are also used in this manual:

Convention	Meaning
<b>Ctrl/ x</b>	A sequence such as <b>Ctrl/ x</b> indicates that you must hold down the key labeled Ctrl while you press another key or a pointing device button.
PF1 x	A sequence such as PF1 x indicates that you must first press and release the key labeled PF1 and then press and release another key or a pointing device button.
<b>Return</b>	In examples, a key name enclosed in a box indicates that you press a key on the keyboard. (In text, a key name is not enclosed in a box.)
...	A horizontal ellipsis in examples indicates one of the following possibilities: <ul style="list-style-type: none"> <li>• Additional optional arguments in a statement have been omitted.</li> <li>• The preceding item or items can be repeated one or more times.</li> <li>• Additional parameters, values, or other information can be entered.</li> </ul>
. . .	A vertical ellipsis indicates the omission of items from a code example or command format; the items are omitted because they are not important to the topic being discussed.
( )	In command format descriptions, parentheses indicate that you must enclose the options in parentheses if you choose more than one.
[ ]	In command format descriptions, brackets indicate optional choices. You can choose one or more items or no items. Do not type the brackets on the command line. However, you must include the brackets in the syntax for OpenVMS directory specifications and for a substring specification in an assignment statement.
[   ]	In command format descriptions, vertical bars separate choices within brackets or braces. Within brackets, the choices are options; within braces, at least one choice is required. Do not type the vertical bars on the command line.
{ }	In command format descriptions, braces indicate required choices; you must choose at least one of the items listed. Do not type the braces on the command line.
<b>bold text</b>	This typeface represents the introduction of a new term. It also represents the name of an argument, an attribute, or a reason.
<i>italic text</i>	Italic text indicates important information, complete titles of manuals, or variables. Variables include information that varies in system output (Internal error <i>number</i> ), in command lines ( <code>/PRODUCER= name</code> ), and in command parameters in text (where <i>dd</i> represents the predefined code for the device type).
UPPERCASE TEXT	Uppercase text indicates a command, the name of a routine, the name of a file, or the abbreviation for a system privilege.
Monospace type	Monospace type indicates code examples and interactive screen displays.  In the C programming language, monospace type in text identifies the following elements: keywords, the names of independently compiled external functions and files, syntax summaries, and references to variables or identifiers introduced in an example.

<b>Convention</b>	<b>Meaning</b>
-	A hyphen at the end of a command format description, command line, or code line indicates that the command or statement continues on the following line.
numbers	All numbers in text are assumed to be decimal unless otherwise noted. Nondecimal radices—binary, octal, or hexadecimal—are explicitly indicated.



---

# Part I. Introduction

Part I contains information about using the remote management features of ACMS. It contains an overview of the Remote Manager, as well as information on how it is managed and operates. It also contains information on how to manage data collection and how to use the Remote Manager to modify a running ACMS system. Finally, this part shows you how to write programs that perform remote management using RPC and SNMP.

---



# Chapter 1. Overview of Remote Management

This chapter provides an overview of ACMS remote management.

## 1.1. Architecture and Implementation

The ACMS Remote Manager provides ACMS system managers with the capability of monitoring and managing their ACMS application environment across a network. The facilities that comprise the Remote Manager are based on a client/server architecture. Two protocols are supported for accessing the ACMS remote management server: Open Network Computing Remote Procedure Call (ONC RPC), which is used by command line utilities (provided with the remote management option) and can be called directly from user-written programs; and Simple Network Management Protocol (SNMP), for use with third-party management consoles.

Figure 1.1 shows the architecture of the ACMS Remote Manager.

**Figure 1.1. ACMS Remote Manager Architecture**

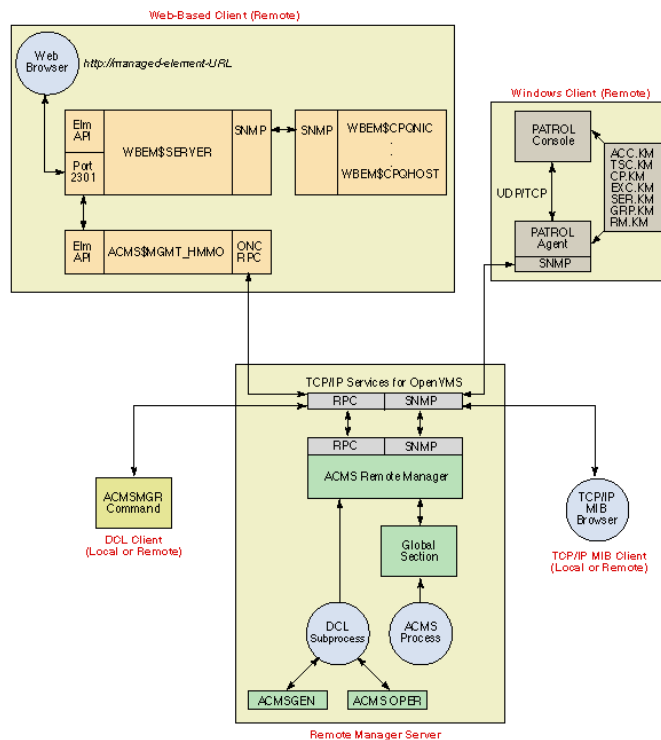

As Figure 1.1 shows, users communicate with the ACMS Remote Manager using one of the supported interfaces over a TCP/IP network. Communications between the ACMS Remote Manager and the ACMS run-time system are transparent. Users may be on the same or a different node than the Remote Manager, but the Remote Manager must be running on the same node as the ACMS run-time system it is monitoring or accessing.

The **command line utility** provides command line access to management information as well as control of the Remote Manager process. This utility uses the RPC interface and can be run from any OpenVMS node that has TCP/IP network connectivity to the ACMS node.

The **SNMP interface** provides network access to ACMS management information using the industry standard SNMP protocol. This protocol is supported by most leading system management packages (including PATROL ® from BMC ® and Compaq Insight Manager from Compaq).

The **RPC interface** provides local or remote access to ACMS management information and is used by user-written programs to access ACMS management information.

ACMS system managers control the data being collected as well as automatic variable monitoring and the management interfaces themselves through either SNMP or RPC commands.

The Remote Manager obtains initial configuration information during process startup from a user-maintained configuration file (described in Chapter 4). Once started, the Remote Manager provides ACMS system managers remote access to their ACMS application environment through the interfaces.

## 1.2. Remote Management Capabilities

The Remote Manager provides ACMS system managers with the ability to:

- Remotely manage the Remote Manager (Chapter 4)
- Remotely manage data collection (Section 5.1), including:
  - Remotely configure SNMP traps
  - Remotely view ACMS Management Information on line
- Remotely modify ACMS run-time systems (Section 5.3)
- Write programs that remotely access management information on line using ONC RPC (Chapter 6) and SNMP (Chapter 7)

# Chapter 2. Getting Started with the ACMS Remote Manager

This chapter describes how to prepare and run the ACMS Remote Manager software on a node where *VSI ACMS Version 4.3 for OpenVMS* has been installed. This chapter does not describe the actual installation. For information about installing *VSI ACMS Version 4.3 for OpenVMS*, refer to the *VSI ACMS Version 5.0 for OpenVMS Installation Guide*.

---

## Note

The procedures in this chapter assume VSI TCP/IP Services Version 5.0 for OpenVMS or higher is installed. The image and process names changed in Version 5.0 from UCX\* to TCPIP\*. If you are using a machine with an older version of TCP/IP Services installed, you should substitute UCX wherever you see TCPIP in the instructions in this chapter.

---

## Terminology

The following terms are used in this chapter:

- **Server node**

A node on which ACMS Version 4.3 has been installed and on which the ACMS Remote Manager server will run. Server nodes can be either ACMS application or submitter nodes, and can be managed either locally or remotely using one of the supported interfaces (RPC or SNMP). Server nodes are automatically client nodes, but not all client nodes are server nodes.

- **Client node**

A node on which ACMS Version 4.3 may or may not be installed. Client nodes can get information from and perform operations on server nodes. However, users cannot obtain ACMS system management information from or perform system management functions on nodes that are client nodes only.

## 2.1. Running the ACMS Remote Manager

The following sections outline the steps required to get the ACMS Remote Manager running on an OpenVMS system. If you are an inexperienced user of ACMS, you should first read Section 2.2 and Section 2.3 for detailed information about how to set up a node for ACMS remote management.

This section describes setup for both client and server nodes. Server nodes automatically support all client functions; once a node is set up as a server, it can function as a client and a server without additional work. Client nodes can function only as clients.

When you complete the following procedures, the ACMS Remote Manager will be running on your system and you can access it using the ACMSMGR command line utility.

### 2.1.1. Server Node Setup

Before you begin, you must have already installed the ACMS Version 4.3 kit on your system. Also ensure that you have the minimum supported version of TCP/IP (as described in the ACMS Software

Product Description [SPD 25.50. xx]) installed on your node, and that it is operational. (If TCP/IP is not installed and operational, the ACMS Remote Manager will not run.) For information about TCP/IP setup, see Section 2.2.

Once you have installed the ACMS and TCP/IP software, perform the following steps to set up a Remote Manager server node:

1. Verify Portmapper (RPC) setup (see Section 2.1.1.1)
2. Run the ACMS postinstallation procedure (see Section 2.1.1.2)
3. Define process logicals and symbols (see Section 2.1.1.3)
4. Prepare the ACMS environment (see Section 2.1.1.4)
5. Start the ACMS Remote Manager (see Section 2.1.1.5)

Server nodes are automatically client nodes. Therefore, you do not need to perform the tasks in Section 2.1.2 for nodes that you set up as server nodes.

### 2.1.1.1. Verify Portmapper (RPC) Setup

Before you attempt to start the Remote Manager, ensure that the proper TCP/IP support is in place. This section provides an overview of the Portmapper (RPC) verification process. If you need more detailed information, or if you will be using third-party tools or writing your own SNMP management tools, see Section 2.2.

1. Look for the process TCPIP\$PORTM (UCX\$PORTM on older versions):

```
$ SHOW SYSTEM/PROCESS=TCPIP*
```

If you find the TCPIP\$PORTM process, RPC is running and you can skip to Section 2.1.1.2. Otherwise, go to step 2.

2. See whether the Portmapper service is enabled:

```
$ TCPIP
TCPIP> SHOW SERVICE PORTMAPPER
```

Service	Port	Proto	Process	Address	State
PORTMAPPER	111	TCP,UDP	TCPIP\$PORTM	0.0.0.0	Enabled

The Portmapper should have both the TCP and UDP protocols defined. If it does not, you may need to configure the Portmapper (see Section 2.2.1). If the Portmapper state is Enabled, skip to Section 2.1.1.2. Otherwise, go to step 3.

3. To enable the Portmapper, enter the following commands:

```
$ TCPIP
TCPIP> ENABLE SERVICE PORTMAPPER
TCPIP> SET CONFIGURATION ENABLE SERVICE PORTMAPPER
TCPIP> EXIT
```

Then restart TCP/IP. The Portmapper process does not automatically start when TCP/IP starts, so you may not see the TCPIP\$PORTM process. The process starts the first time the Portmapper is accessed.

### 2.1.1.2. Run the ACMS Postinstallation Procedure

If you did not run the postinstallation procedure when you installed the ACMS Version 4.3 kit, do so now. For details, see Section 2.3.

1. Run the postinstallation procedure as follows:

```
$ @SYS$STARTUP:ACMS_POST_INSTALL
```

2. When you are asked whether you want to configure the ACMS Remote Manager, answer YES:

```
Do you want to SETUP and CONFIGURE the ACMS Remote System Manager [Y]?  
YES
```

3. Answer the questions according to the needs of your organization.

### 2.1.1.3. Define Process Logicals and Symbols

The ACMS\$MGMT\_ENV.COM command procedure is provided to define some symbols that make using the ACMSMGR utility simpler. For more information, see Section 2.3.2, or run the procedure now by entering the following command:

```
$ @SYS$STARTUP:ACMS$MGMT_ENV.COM
```

### 2.1.1.4. Prepare the ACMS Environment

You are now ready to start the Remote Manager. If you need more information about this procedure, see Section 2.3.3. Then follow these steps:

1. Ensure that the ACMSTART.COM procedure has been run by entering the following command:

```
$ ACMS/SHOW SYSTEM
```

If you get the following error, you must invoke the SYS\$STARTUP:ACMSTART.COM procedure described in step 2:

```
%DCL-W-ACTIMAGE, error activating image ACMSHR
```

If you get a message indicating that the ACMS system is stopped, or if some information about the ACMS system is displayed, go to Section 2.1.1.5.

2. Invoke the ACMSTART command procedure:

```
$ @SYS$STARTUP:ACMSTART
```

### 2.1.1.5. Start the ACMS Remote Manager

To start the ACMS Remote Manager, follow these steps:

1. Enter the following command:

```
$ STARTMGR
```

2. Check that the ACMS\$MGMT\_SVR process started by entering the following command:

```
$ SHOW SYSTEM/PROCESS=ACMS$MGMT_SVR
```

3. If the process is running, you should be able to communicate with it using ACMSMGR commands (see Section 2.1.3).

If the process is not running, you can look for information in either of two places:

- Type out the `SYSS$ERRORLOG:ACMS$MGMT_SERVER.OUT` text file:

```
$ TYPE/PAGE SYSS$ERRORLOG:ACMS$MGMT_SERVER.OUT
```

- View the Remote Manager log file by using the following command:

```
$ ACMSMGR SHOW LOG/LOCAL
```

For more information about these sources, refer to Section 2.4.2.1 and Section 2.4.2.2.

## 2.1.2. Client Node Setup

All ACMS Remote Manager client nodes require that TCP/IP be installed and operational. (For information about TCP/IP setup, refer to Section 2.2.) Other than TCP/IP connectivity to the server node, no additional TCP/IP setup is required. (The Portmapper does not need to be running on the client node.)

The following sections describe how to set up an ACMS Remote Manager client node. You can skip these sections if you are installing the ACMS Remote Management server; server nodes are automatically client nodes.

If the client node will not be used as an ACMS submitter node, the ACMS Remote Option kit does not need to be installed. How you set up the client node depends upon whether the ACMS Remote Option kit has been installed.

- If the ACMS Remote Option kit has been installed, simply run the `ACMS_POST_INSTALL.COM` command procedure (see Section 2.1.2.1).
- If the ACMS Remote Option kit has not been installed, you must copy some files and define several symbols before you can use the ACMSMGR utility on a client node (see Section 2.1.2.2).

Once you have completed these tasks, you can try to communicate with a Remote Manager on a server node using the procedure in Section 2.1.3.

Note that you cannot obtain ACMS system management information or perform system management functions on nodes that are client nodes only. Client nodes can get information from and perform operations on server nodes only.

### 2.1.2.1. Run ACMS\_POST\_INSTALL.COM

Follow these steps to run the `ACMS_POST_INSTALL.COM` command procedure:

1. Run the postinstallation procedure as follows:

```
$ @SYS$STARTUP:ACMS_POST_INSTALL
```

2. When you are asked whether you want to configure the ACMS Remote System Manager, answer YES:

```
Do you want to SETUP and CONFIGURE the ACMS Remote System Manager [Y]?  
YES
```

3. Answer the questions according to the needs of your organization.
4. Now execute the `ACMS$MGMT_ENV.COM` command procedure to define some symbols that make using the `ACMSMGR` utility simpler:

```
$ @SYS$STARTUP:ACMS$MGMT_ENV.COM
```

### 2.1.2.2. Copy Files and Define Symbols

If you did not install the ACMS Remote Option kit (that is, if this node will not be an ACMS submitter node), follow this procedure. You will need access to a node with one of the ACMS Version 4.3 Run-Time kits installed.

1. Copy the `ACMSMGR` executable to your node from `SYSS$SYSTEM` on the node that has ACMS Version 4.3 installed. Which executable to copy depends on the version of Compaq TCP/IP Services for OpenVMS (TCP/IP) you have installed:
  - If you are running Version 4.2 of Compaq TCP/IP, copy the `ACMS$MGMT_CMD_UCX.EXE` file to `SYSS$SYSTEM` on your node.
  - If you are running TCP/IP Version 5.0 or higher, copy the `ACMS$MGMT_CMD_TCPIP.EXE` file to `SYSS$SYSTEM` on your node.
2. Copy `ACMS$MGMT_ENV.COM` to your node and run it. This file is located in `SYSS$STARTUP` of a node where ACMS Version 4.3 is installed. `ACMS$MGMT_ENV.COM` defines some symbols that make using the `ACMSMGR` utility simpler. Execute the command procedure as follows:

```
$ @SYS$STARTUP:ACMS$MGMT_ENV.COM
```

### 2.1.3. Communicate with the Remote Manager

Before you issue any `ACMSMGR` commands, you must either log in to the Remote Manager (see step 1) or use an ACMS proxy (see step 2). For detailed information, see Section 2.3.5.

1. To log in to the Remote Manager, you must have a valid user account and password on the node on which the Remote Manager is running. The following example commands log in to the Remote Manager on node `SERVER`, using account `MYACCT` and password `MYPASS`. (For more details, see Section 2.3.5.1.)

```
$ DEFINE ACMS$MGMT_SERVER_NODE SERVER
$ DEFINE ACMS$MGMT_USER MYACCT
$ ACMSMGR LOGIN
```

```
ACMS Remote Management -- Command line utility
Password:MYPASS
```

If the login succeeds, no messages are displayed. Go to step 3.

If the login fails, check the following possible reasons:

- You typed in an invalid user name or password.
- You defined the `ACMS$MGMT_SERVER_NODE` logical incorrectly (wrong or misspelled node name).

- You defined the ACMS\$MGMT\_USER logical incorrectly (wrong or misspelled node name).
- The Remote Manager is not running on the node you specified.

Refer to Section 2.4 for more help.

2. If you will be using ACMS proxies to access the Remote Manager, and you already know that you have a valid proxy account, go to step 3. If you have not set up proxies but would like to use them, create a proxy file on the node on which the Remote Manager will run. (For more information, see Section 2.3.5.2.)

```
$ SET DEFAULT SYS$SYSTEM $ MCR ACMSUDU UDU> CREATE/PROXY
```

Now you can add a proxy. To add a proxy, you need to know the following information:

- The nodes and accounts from which you will access the Remote Manager
- The account on the Remote Manager node you will use

For example, assume you will be on node CLIENT using account MYACCT, and you will be accessing node SERVER using account SRVACCT. Enter the following command on node SERVER:

```
UDU> ADD/PROXY CLIENT::MYACCT SRVACCT
```

3. You can now enter any of the ACMSMGR commands. For example:

```
$ ACMSMGR SHOW INTERFACES
```

This command results in output similar to the following:

```
ACMS Remote Management -- Command line utility
```

```
ACMS V4.4-0 Interfaces Display                               Time: 18-APR-2001
13:59:15.51
```

Node	Interface	Enabled State	Running State	Get Requests	Set Requests	Alarms Sent	Time Last Alarm Sent
SERVER	rpc	enabled	started	987	0	0	17-NOV-1858
	00:00:00.00						
SERVER	snmp	enabled	started	0	0	0	17-NOV-1858
	00:00:00.00						

If you get error messages instead, refer to Section 2.4.

## 2.2. TCP/IP Setup

There are two components to the TCP/IP setup for the ACMS Remote Manager:

- Portmapper (RPC) setup (see Section 2.2.1)

Portmapper setup is required if you will be using the DCL command line utility ACMSMGR for remote management, or if you intend to write your own programs using the RPC API.

- SNMP setup (see Section 2.2.2)



SNMP setup is required if you will be using third-party tools (such as PATROL from BMC) for remote system management, or if you will be writing your own SNMP management tools.

The information in the following sections applies only to nodes on which the ACMS Remote Manager will run. It is not relevant for ACMS Remote Manager client nodes.

## 2.2.1. Set Up the Portmapper (RPC)

Perform this task if the Portmapper has not previously been set up on the node you are using, or if it has been set up incorrectly.

The procedure described here may require a restart of TCP/IP on the node you are using.

---

### Note

When you configure RPC, you are providing network access to the node. This may have significant security implications. Be sure you understand these implications before you configure SNMP. If you are in doubt, consult your network or security administrator.

---

### 2.2.1.1. Determine the Current Portmapper Configuration

To determine whether the Portmapper is configured, use the following commands:

```
$ TCPIP TCPIP> SHOW SERVICE PORTMAPPER
```

If the Portmapper is configured, you will see a display similar to the following:

Service	Port	Proto	Process	Address	State
PORTMAPPER	111	TCP,UDP	TCPIP\$PORTM	0.0.0.0	Enabled

If you get an error message indicating that the record is not found, or if both protocols are shown but the state is not Enabled, go to Section 2.2.1.3.

If the service is displayed, make sure that both TCP and UDP are shown in the "Proto" column and that the state is Enabled. If both protocols are not shown or if you suspect that the Portmapper is not working correctly, go to Section 2.2.1.2.

If both protocols are shown and the state is Enabled, then the Portmapper is configured on this node and no additional work must be performed.

### 2.2.1.2. Remove the Existing Portmapper Configuration

Perform this task if you suspect the Portmapper is not working correctly, or if you were directed here from Section 2.2.1.1.

Enter the following commands:

```
$ TCPIP TCPIP> SET NOSERVICE PORTMAPPER
```

Enter Y at the "Remove? [N]:" prompt, and then exit the utility.

Now shut down and restart TCP/IP on this node:

```
$ @SYS$STARTUP:TCPIP$SHUTDOWN
$ @SYS$STARTUP:TCPIP$STARTUP
```

---

## Note

If you logged in to this node using TCP/IP, you will lose connectivity after the first command executes. You may have to reboot the machine in order to log in and complete the procedure. To avoid this problem, put the shutdown and startup commands into a command procedure, and submit the procedure to a batch queue that is guaranteed to run on this node.

---

### 2.2.1.3. Configure the Portmapper

To configure the Portmapper, run the SYSS\$MANAGER:TCPIP\$CONFIG command procedure. Select option 3 (Server components) and then option 8 (PORTMAPPER). Select the option to "Enable service on this node." For example:

```
$ @SYS$MANAGER:TCPIP$CONFIG

Compaq TCP/IP Services for OpenVMS Configuration Menu

Configuration options:

    1 - Core environment
    2 - Client components
    3 - Server components
    4 - Optional components
    5 - Shutdown Compaq TCP/IP Services for OpenVMS
    6 - Startup Compaq TCP/IP Services for OpenVMS
    7 - Run tests

    A - Configure options 1 - 4
    [E] - Exit configuration procedure

Enter configuration option: 3

Compaq TCP/IP Services for OpenVMS SERVER Components Configuration Menu

Configuration options:

    1 - BIND           Disabled
    2 - BOOTP          Disabled
    3 - TFTP           Disabled
    4 - FTP            Enabled
    5 - LPR/LPD        Disabled
    6 - NFS            Disabled
    7 - PC-NFS         Disabled
    8 - PORTMAPPER     Enabled
    9 - TELNET/RLOGIN  Enabled
   10 - SNMP           Enabled
   11 - NTP            Disabled
   12 - METRIC         Disabled
   13 - POP            Disabled
   14 - FINGER         Disabled
   15 - RMT            Disabled
   16 - LBROKER        Disabled
   17 - DHCP           Disabled
```

```
A - Configure options 1 - 17
[E] - Exit menu
```

Enter configuration option: 8

PORTMAPPER SERVER configuration options:

```
1 - Enable service on all nodes
2 - Enable service on this node

E - Exit PORTMAPPER configuration
```

Enter configuration option: 2

To exit from the command procedure, enter E twice.

Now shut down and restart TCP/IP on this node:

```
$ @SYS$STARTUP:TCPIP$SHUTDOWN
$ @SYS$STARTUP:TCPIP$STARTUP
```

---

## Note

If you logged in to this node using TCP/IP, you will lose connectivity after the first command executes. You may have to reboot the machine in order to log in and complete the procedure. To avoid this problem, put the shutdown and startup commands into a command procedure, and submit the procedure to a batch queue that is guaranteed to run on this node.

---

After TCP/IP starts up, the Portmapper should be ready to use. The Portmapper process itself does not start until it is needed, but you should make sure it is defined as described in Section 2.2.1.1.

You can test RPC access to the Remote Manager by using ACMSMGR commands. But you will need to get the ACMSMGR running first (see Section 2.3).

## 2.2.2. Set Up SNMP

Perform this task if SNMP is not set up on the node you are using, or if SNMP is set up incorrectly.

This procedure may require that you restart TCP/IP on the node you are using.

---

## Note

When you configure SNMP, you must configure the SNMP communities to which the node will belong. SNMP communities govern SNMP network access to the node, which may have significant security implications. Be sure you understand these implications before you configure SNMP. If you are in doubt, consult your network or security administrator. If the SNMP communities are not configured properly, you may be unable to access the ACMS Remote Manager.

---

### 2.2.2.1. Determine the Current SNMP Configuration

To determine whether SNMP is configured, enter the following commands:

```
$ TCPIP TCPIP> SHOW SERVICES
```

If SNMP is configured, you will see a display similar to the following:

Service	Port	Proto	Process	Address	State
...					
ESNMP	242	UDP	ESNMP	0.0.0.0	Disabled
SNMP	161	UDP	TCPIP\$SNMP	0.0.0.0	Enabled
...					

If you do not see both of these services, proceed to Section 2.2.2.3. If both services are displayed, SNMP is configured on this node. If you suspect that SNMP is not working correctly, you can proceed to Section 2.2.2.2. Otherwise, there is no additional work to be performed. (Note: It is fine if ESNMP has a state of Disabled.)

### 2.2.2.2. Remove the Existing SNMP Configuration

Perform this step if you suspect SNMP is not working correctly or if you were directed here from Section 2.2.2.1.

Enter the following commands:

```
$ TCPIP TCPIP> SET NOSERVICE SNMP
```

Enter Y at the "Remove? [N]:" prompt, and then enter:

```
TCPIP> SET NOSERVICE ESNMP
```

Enter Y again at the "Remove? [N]:" prompt, and then exit the utility.

Now shut down and restart TCP/IP on this node:

```
$ @SYS$STARTUP:TCPIP$SNMP_SHUTDOWN  
$ @SYS$STARTUP:TCPIP$SNMP_STARTUP
```

### 2.2.2.3. Configure SNMP

To configure SNMP, run the SYSS\$MANAGER:TCPIP\$CONFIG command procedure. Select option 3 (Server components) and then option 10 (SNMP Configuration). Select the option to "Enable service on this node", and respond to the prompts as shown in the following example.

---

#### Note

Configuring SNMP communities must be coordinated among all nodes that will participate. If you are unsure which SNMP communities to configure, contact your network administrator.

---

```
$ @SYS$MANAGER:TCPIP$CONFIG
```

```
Compaq TCP/IP Services for OpenVMS Configuration Menu
```

```
Configuration options:
```

- 1 - Core environment
- 2 - Client components
- 3 - Server components
- 4 - Optional components
- 5 - Shutdown Compaq TCP/IP Services for OpenVMS

- 6 - Startup Compaq TCP/IP Services for OpenVMS
- 7 - Run tests
  
- A - Configure options 1 - 4
- [E] - Exit configuration procedure

Enter configuration option: 3

Compaq TCP/IP Services for OpenVMS SERVER Components Configuration Menu

Configuration options:

- 1 - BIND Disabled
- 2 - BOOTP Disabled
- 3 - TFTP Disabled
- 4 - FTP Enabled
- 5 - LPR/LPD Disabled
- 6 - NFS Disabled
- 7 - PC-NFS Disabled
- 8 - PORTMAPPER Enabled
- 9 - TELNET/RLOGIN Enabled
- 10 - SNMP Enabled
- 11 - NTP Disabled
- 12 - METRIC Disabled
- 13 - POP Disabled
- 14 - FINGER Disabled
- 15 - RMT Disabled
- 16 - LBROKER Disabled
- 17 - DHCP Disabled
- A - Configure options 1 - 17
- [E] - Exit menu

Enter configuration option: 10

SNMP SERVER configuration options:

- 1 - Enable service on all nodes
- 2 - Enable service on this node
  
- E - Exit PORTMAPPER configuration

Enter configuration option: 2

Do you want to provide the public community [Y]: <site dependent>  
Do you want to provide another community [N]: <site dependent>  
Enter contact person(s): <site administrator>  
Enter the location of the system: <site location>

To exit from the command procedure, enter E twice.

After exiting from the procedure, you may need to modify the public communities you just specified to allow SNMP reads, writes, or traps. The following example shows how to do so. (Community names are case sensitive. Also note the use of double quotes.) To allow SNMP writes to occur on the node, you also need to enable the set flag, as follows:

```
$ TCPIP
TCPIP> SET CONFIG SNMP/COMMUNITY="PUBLIC"/TYPE=WRITE
```

```
TCPIP> SET CONFIG SNMP/COMMUNITY="PUBLIC" /TYPE=TRAP
TCPIP> SET CONFIG SNMP/FLAGS=SETS
```

Now exit the TCP/IP utility and restart TCP/IP on this node:

```
$ @SYS$STARTUP:TCPIP$SHUTDOWN
$ @SYS$STARTUP:TCPIP$STARTUP
```

---

## Note

If you logged in to this node using TCP/IP, you will lose connectivity after the first command executes. You may have to reboot the machine in order to log in and complete the procedure. To avoid this problem, put the shutdown and startup commands into a command procedure, and submit the procedure to a batch queue that is guaranteed to run on this node.

---

After TCP/IP starts, SNMP should be ready to use. The following SNMP processes should be running:

```
TCPIP$ESNMP
TCPIP$OS_MIBS
```

### 2.2.2.4. Test SNMP

TCP/IP includes a DCL command line utility that can be used to issue SNMP commands to SNMP agents on OpenVMS. To use this utility, define the following foreign commands:

```
$ SNMPGET ::= $SYS$SYSTEM:TCPIP$SNMP_REQUEST
<your node name> PUBLIC GET -W 20 $ SNMPSET ::= $SYS$SYSTEM:TCPIP
$SNMP_REQUEST
<your node name> PUBLIC SET -W 20
```

Then, after starting the ACMS Remote Manager (see Section 2.3), test access to SNMP:

```
$ SNMPGET 1.3.6.1.4.1.36.2.18.48.5.1.10.1
1.3.6.1.4.1.36.2.18.48.5.1.10 = 14

$ SNMPSET 1.3.6.1.4.1.36.2.18.48.5.1.10.1 -I 15
1.3.6.1.4.1.36.2.18.48.5.1.10 = 15
```

In this example, the first command issues an SNMP GET to get the value of the parameter `mgr_audit_level` (the audit level of the main thread). The second command sets the value of the `mgr_audit_level` parameter to 15 (log all messages). Following each command, the current value of the field is returned.

If these commands fail to return the expected results, refer to Section 2.4.

## 2.3. Remote Manager Setup

Setting up the Remote Manager primarily involves preparing the OpenVMS environment to start the Remote Manager. While many of the steps in this procedure can be performed without having previously configured TCP/IP, it is strongly suggested that you perform TCP/IP setup tasks described in Section 2.2 before you attempt to start and access the Remote Manager.

Most of what you need to know to set up the ACMS Remote Manager is covered in Chapter 4. Please read that chapter before you set up the ACMS Remote Manager.

## 2.3.1. Run the Postinstallation Procedure

The postinstallation procedure creates two important command procedures:

- ACMS\$MGMT\_SETUP.COM
- ACMS\$MGMT\_ENV.COM

Both of these procedures are required to start and run the ACMS Remote Manager successfully.

In addition, the postinstallation procedure modifies ACMSTART.COM to execute ACMS\$MGMT\_SETUP.COM to ensure that important logicals are defined whenever the ACMS run-time system is started.

Run the ACMS\_POST\_INSTALL.COM command procedure as follows:

```
$ @SYS$STARTUP:ACMS_POST_INSTALL
```

Respond appropriately to all prompts until you reach the following prompt:

```
Do you want to SETUP and CONFIGURE the ACMS Remote System Manager [Y]?
```

Be sure to respond YES (the default) to this prompt. Several more questions are posed. The procedure continues with the following questions. Your responses are stored in the ACMS\$MGMT\_SETUP.COM file.

```
Do you want to allow Proxy Authorization [Y]?
```

All clients must be authenticated and authorized to access the ACMS Remote Manager. Proxy access allows ACMS proxies to be used for this purpose. Proxy access is described in detail in Section 4.4.1.2.

Enter Y to enable proxy authentication and authorization when the Remote Manager is started.

```
(ACMS$MGMT_CONFIG) Enter the file specification for the configuration
file used by the ACMS Remote Manager
Equivalence string [ SYS$SPECIFIC:[SYSEXE]ACMS$MGMT_CONFIG.ACM ]:
```

The configuration file contains the default startup configuration for both ACMS data collections and the Remote Manager. Section 4.2 describes how to use the ACMSCFG utility to manage this file. The default location is SYS\$SYSROOT:[SYSEXE]ACMS\$MGMT\_CONFIG.ACM. The information in this file is not node dependent; however, you may choose to configure the nodes in your cluster differently. If you configure all nodes in the cluster the same, you can put this file in the cluster common root. Otherwise, the default value places it in the node-specific root.

Either press Return to accept the default, or type the file specification you want to use.

```
(ACMS$MGMT_TEMP) Enter the directory where the temp command procedures
will be created
Equivalence string [ SYS$SPECIFIC:[SYSMGR] ]:
```

The Remote Manager uses temporary command procedures (see Section 5.3.2 to update the ACMS run-time system. The default location of the command procedures is SYS\$MANAGER. This directory should not be a cluster common directory.

Either press Return to accept the default, or type the directory specification you want to use. If the directory does not exist, the command procedure creates it for you.

(ACMS\$MGMT\_LOG) Enter the directory for the ACMS Remote Manager's Log file Equivalence string [ SYS\$SPECIFIC:[ACMS\_RM.LOG] ]:

The Remote Manager log file (described in Section 4.7 contains a variety of messages generated by the Remote Manager at run time. The default location of the audit log is SYSSYSROOT:[ACMS\_RM.LOG]ACMS\$MGMT\_LOG.LOG. If you choose to place this log in a cluster common directory, be sure that the file name is different for each node.

Either press Return to accept the default, or type the file specification you want to use.

(ACMS\$MGMT\_CREDS\_DIR) Enter the directory for the ACMS Remote Manager Credential's Equivalence string [ SYS\$SPECIFIC:[ACMS\_RM.CREDS] ]:

Client credential files (described in Section 4.4.1.1 contain encrypted client identity information used for client authorization. The default location for these files is SYSSYSROOT:[ACMS\_RM.CREDS]. Credential files are created with unique names and can be safely placed in a cluster common directory.

Either press Return to accept the default, or type the directory specification you want to use. If the directory does not exist, the command procedure creates it for you.

Please enter the UIC for the ACMS\$SNMP account, in the form [ggggg,nnnnn]  
UIC:

This account is used to control SNMP access to ACMS system management information and functions. Section 4.4.1 and Section 7.2 describe the uses of this account. In general, if you will be using an SNMP-based management console to access ACMS, you should create this account.

Please enter a password of at least 8 characters, using only the following characters: ABCDEFGHIJKLMNOPQRSTUVWXYZ0123456789\$\_

Password:

The password for this account is never used. Enter any combination of the characters shown. However, keep in mind that you will be prompted to verify whatever you type.

After you run the postinstallation procedure, you should rerun SYS\$STARTUP:ACMSTART.COM to ensure that the newly created ACMS\$MGMT\_SETUP.COM is run.

## 2.3.2. Define Process Logicals and Symbols

Four symbols are defined in the ACMS\$MGMT\_ENV.COM procedure:

- ACMSMGR: Used to invoke the ACMSMGR utility, which provides remote access to the ACMS Remote Manager. The ACMSMGR utility is described in detail in Chapter 11.
- ACMSCFG: Used to invoke the ACMSCFG utility, which allows the Remote Manager configuration file to be managed. The ACMSCFG utility is described in detail in Chapter 10.
- ACMS\$SNAP (and ACMS\$SNAP): Used to invoke the ACMS\$SNAP utility, which enables users to view ACMS Remote Manager data snapshot files. This utility and its use is described in detail in Chapter 12.
- STARTMGR: Used to invoke the Remote Manager startup procedure.
- SNMPGET and SNMPSET: Used to issue SNMP get and set commands to the Remote Manager. Requires knowledge of ACMS MIB OIDs, which are listed in the file MIB\_OID.LIS available from the directory ACMS\$RM\_EXAMPLES.



Before you attempt to run any of these utilities, run the ACMS\$MGMT\_ENV.COM procedure:

```
$ @SYS$STARTUP:ACMS$MGMT_ENV.COM
```

### 2.3.3. Review and Update the Configuration File

The ACMS\$MGMT\_CONFIG system logical points to the configuration file. This logical is defined in the ACMS\$MGMT\_SETUP.COM procedure, which is executed by the ACMSTART.COM procedure. If this logical is not defined, the ACMSCFG utility will not be able to locate the file. If you have not already run ACMSTART.COM, do so before issuing any ACMSCFG commands.

The ACMS\_POST\_INSTALL.COM procedure creates a configuration file with default values in SYS\$SYSROOT:[SYSEXE]ACMS\$MGMT\_CONFIG.ACM.

The configuration file contains the startup configuration for ACMS data collections and provides many defaults for the Remote Manager. Section 4.2 describes how to use the ACMSCFG utility to manage this file.

In particular, consider the following:

- Interfaces

By default, both RPC and SNMP interfaces are enabled. The RPC interface must be enabled if you intend to use the ACM\$MGR command line utility, or if you will be writing programs that use the RPC API. The SNMP interface is required only if you will use a third-party SNMP management tool to manage ACMS. The following command disables the SNMP interface:

```
$ ACMSCFG SET INTERFACE/INTERFACE=SNMP/STATE=DISABLED
```

- Data collections

By default, only ID and CONFIG class data is collected by all ACMS processes. If you intend to use the Remote Manager to monitor run-time or pool data, you must enable data collection for those classes. The following commands enable run-time and pool data collection for all processes:

```
$ ACMSCFG ADD COLL/ENT=*/CLASS=RUNTIME/COLL_STATE=ENABLED  
$ ACMSCFG ADD COLL/ENT=*/CLASS=POOL/COLL_STATE=ENABLED
```

- Traps

Configuring traps is optional. Traps are used only if your SNMP management console listens for traps. Section 7.8 discusses traps in more detail. If you are unsure about whether you need to configure traps, use the defaults.

- Parameters

The parameters in the configuration file control various aspects of the Remote Manager. In general, use the default values unless you have a particular reason to modify them. Refer to Section 9.9 includes a table with descriptions of each parameter.

### 2.3.4. Start the Remote Manager

At this point, you can start the Remote Manager. You can start the Remote Manager before or after you start the ACMS run-time system. Start the Remote Manager by entering the following command:

```
$ STARTMGR
```

If you prefer, you can run the startup procedure directly:

```
$ @SYS$STARTUP:ACMS$MGMT_STARTUP
```

Once this command completes, you should be able to see the Remote Manager process running by issuing the following command:

```
$ SHOW SYSTEM/PROCESS=ACMS$MGMT_SVR
```

If this process is not running, refer to Section 2.4.

## 2.3.5. Communicate with the Remote Manager

If the ACMS\$MGMT\_SVR process is running and you have enabled both the RPC interface and proxy access, you should be able to communicate with the Remote Manager. The exact commands you will use depends on the interfaces you have enabled and the mode of authentication you want to use. This section shows two examples of communicating with the Remote Manager:

- Using ACMSMGR and logging in explicitly
- Using ACMSMGR and a proxy account

### 2.3.5.1. Using ACMSMGR and Logging In Explicitly

If you will not be using proxy accounts, or if you have not set them up yet, you can log in directly to the Remote Manager and communicate with it. To reduce typing, define the process logicals ACMS\$MGMT\_USER to be the user account you will log in with, and ACMS\$MGMT\_SERVER\_NODE to be the node on which the Remote Manager is running:

```
$ DEFINE ACMS$MGMT_USER MYNAME  
$ DEFINE ACMS$MGMT_SERVER_NODE NODE_SERVER_RUNS_ON
```

Then you can log in as follows (the ACMSMGR utility will prompt you for your password):

```
$ ACMSMGR LOGIN Password: MYPASSWORD
```

If no error messages are returned, you have successfully logged in to the Remote Manager. You can now issue ACMSMGR commands from this process. Try the following command:

```
$ ACMSMGR SHOW USERS
```

### 2.3.5.2. Using ACMSMGR and a Proxy Account

If you will be using proxy accounts, you must set them up prior to issuing any ACMSMGR commands. If you have already set them up, you can skip to the example ACMSMGR command.

If you have not set up your proxies, you start by running the ACMSUDU utility. It's best to run this from the SYS\$SYSTEM directory, since that is where ACMSUDU expects to find the file in which it stores proxies.

Start ACMSUDU as follows:

```
$ SET DEFAULT SYS$SYSTEM  
$ MCR ACMSUDU UDU>
```

If you have never set up an ACMS proxy before, create the proxy file now. Use the following command:

```
UDU> CREATE/PROXY
```

Now you need to define the proxy accounts. Proxy accounts have three components: the remote node, the remote account, and the local account.

The remote node is the node from which you will be accessing this node. You can either specify a node name or use the asterisk wildcard (\*). Be aware that the Remote Manager treats every access as a remote access. This means that even if you access the Remote Manager only from the same node it runs on, you must create a proxy. In that case, the remote and local nodes are the same.

The remote account is the account on the remote node that will be accessing the Remote Manager. This is the user name on the remote node.

The local account is the account on the local node that will be used for authorization. It must be a valid account on the local node.

To add the proxy record, use the following command:

```
UDU> ADD/PROXY remote-node::remote-account local-account
```

Once the proxy record has been added, you can attempt to access the Remote Manager. Using a proxy does not require a separate login; you just issue the command. Also, do not define the ACMS \$MGMT\_USER logical. If it is defined, the ACMSMGR utility will look for login information and will not attempt proxy access.

Try this command:

```
$ AMCMSGR SHOW USERS/NODE=remote-manager-node
```

If no error messages are returned, a list of users logged in to the Remote Manager will be displayed. To reduce typing when issuing more commands, define the process logical ACMS \$MGMT\_SERVER\_NODE to be the name of the node you want to access; this eliminates the need for using the /NODE qualifier in ACMSMGR commands.

If an error is returned, refer to Section 2.4.

## 2.4. Troubleshooting the ACMS Remote Manager Startup

The following sections provide troubleshooting information for the following problems:

- Problems starting ACMS ( Section 2.4.1)
- Problems starting the ACMS Remote Manager ( Section 2.4.2)
- Problems with ACMSMGR ( Section 2.4.3)

### 2.4.1. Problems Starting ACMS

The following message is displayed when the ACMS run-time system is being started and the ACMS Central Controller (ACC) cannot open the Remote Manager configuration file:

```
%ACMSMGMT-I-CFGNOTOPEN, Unable to open management config file, using defaults
```

Possible reasons for this message include:

- The logical name ACMS\$MGMT\_CONFIG is not defined.

*Solution:* This logical is typically defined in the file SYS\$STARTUP:ACMS\$MGMT\_SETUP.COM, which is created by the SYS\$STARTUP:ACMS\_POST\_INSTALL.COM command procedure. If the ACMS\$MGMT\_SETUP.COM file does not exist, run ACMS\_POST\_INSTALL.COM. If it does exist, edit it and add the definition of ACMS\$MGMT\_CONFIG. In either case make sure to run ACMS\$MGMT\_SETUP.COM, and then run the ACMSCFG utility to create a new, default file.

- The logical name ACMS\$MGMT\_CONFIG does not point to the configuration file, or the file has not been created.

*Solution:* Ensure that the logical is defined properly (see the first bullet). If it is, you can create a new file by running the ACMSCFG utility. ACMSCFG will ask whether you want to create a new file. Answer yes, and then review the default settings.

- The ACC process does not have read access to the file pointed to by the logical name ACMS\$MGMT\_CONFIG.

*Solution:* Modify the permissions on the file and restart ACMS.

- The ACMS\_POST\_INSTALL.COM procedure has not been run.

*Solution:* Run this procedure to prepare your system to run the ACMS Remote Manager. See the first bullet for more information.

## 2.4.2. Problems Starting the ACMS Remote Manager

The Remote Manager writes error messages to two locations. If you are experiencing problems with the Remote Manager, check both locations for messages.

- SYS\$ERRORLOG:ACMS\$MGMT\_SERVER.OUT (see Section 2.4.2.1)
- Remote Manager log, pointed to by logical ACMS\$MGMT\_LOG (see Section 2.4.2.2)

### 2.4.2.1. ACMS\$MGMT\_SERVER.OUT Messages

This is an ASCII text file that contains the redirected SYS\$OUTPUT from the Remote Manager process. In general, messages appear in this log only if the Remote Manager is unable to write to its log file. The following conditions are exceptions:

- The literal "log\_to\_sysout" is passed to the Remote Manager startup procedure as P1 (for example, @SYS\$STARTUP:ACMS\$MGMT\_STARTUP.COM log\_to\_sysout). Except for rare debugging circumstances, the "log\_to\_sysout" literal should not be passed to the Remote Manager startup procedure as P1.
- The Remote Manager experiences an access violation or other nontrapped fatal error.

Under these circumstances, OpenVMS exception output is written to ACMS\$MGMT\_SERVER.OUT.

If you experience problems with SNMP, refer to Section 7.9 for information about obtaining SNMP debug output.

**LOG: Could not open file acms\$mgmt\_log**

This message indicates that the Remote Manager could not open the file pointed to by the logical ACMS\$MGMT\_LOG. Possible reasons for this include:

- The logical is not defined, or is improperly defined.

*Solution:* This logical is typically defined in the file SYS\$STARTUP:ACMS\$MGMT\_SETUP.COM, which is created by the SYS\$STARTUP:ACMS\_POST\_INSTALL.COM command procedure. If the ACMS\$MGMT\_SETUP.COM file does not exist, run ACMS\_POST\_INSTALL.COM. If it does exist, edit it and add the definition of ACMS\$MGMT\_LOG. In either case, make sure to run ACMS\$MGMT\_SETUP.COM, and then start the Remote Manager again.

- The device is full.

*Solution:* If there is insufficient space for the log file, either redefine the logical to point to another device or make room on the device.

- The Remote Manager does not have write access to the file.

*Solution:* Modify the permissions on the file or directory to which the ACMS\$MGMT\_LOG logical points.

- The ACMS\_POST\_INSTALL.COM procedure has not been run.

*Solution:* Run this procedure to prepare your system to run the ACMS Remote Manager. See the first bullet for more information.

**2.4.2.2. Remote Manager Log Entries**

The messages written to the Remote Manager are determined by Remote Manager parameter settings (for example, mgr\_audit\_level, rpc\_audit\_level, and so on). Changing the parameter values results in either more or fewer messages appearing in the Remote Manager log. By default, messages with a severity of warning (w), error (e), or fatal (f) are written to the Remote Manager log. The log is pointed to by logical ACMS\$MGMT\_LOG.

You can use the ACMSMGR SHOW LOG command to display messages in the Remote Manager log. If the Remote Manager is not running, use the /LOCAL qualifier to read the log file directly. You must be logged in to a node with direct access to the log file in order to use the /LOCAL switch. For instance:

```
$ ACMSMGR SHOW LOG/LOCAL
```

See Section 4.7 for detailed information about the log file maintained by the ACMS Remote Manager.

**mgr: f : Failure opening config file**

The Remote Manager could not open the configuration file. See the discussion in Section 2.4.2.1.

**mgr: f : No Interfaces were enabled. Process will shutdown**

At least one interface must be enabled when the Remote Manager is started. Otherwise, it is impossible to communicate with the Remote Manager. If both interfaces are disabled, the Remote Manager will not start.

*Solution:* Issue the following command to see the current interface settings in the configuration file:

```
$ ACMSCFG SHOW INTERFACE
```

Enable at least one of the interfaces as follows (substitute SNMP for RPC if you want to enable the SNMP interface instead of the RPC interface):

```
$ ACMSCFG SET INTERFACE/INTERFACE=RPC/STATE=ENABLED
```

Now restart the Remote Manager.

### **procmon: e : Failure obtaining current collection states. Bypassingqti**

This message can safely be ignored. It is generated when an ACMS entity is not started and the Remote Manager is parsing the collection table.

### **procmon: f : Failure waiting on mgmt\$x\_proc\_mon\_cond\_var**

This message can safely be ignored. It is generated when the process monitor thread is unexpectedly interrupted, generally during Remote Manager shutdown.

### **Remote Manager hangs during process startup**

Most Remote Manager hangs during process startup are due to problems with the Portmapper. Verify that the Portmapper is functioning properly, and restart the Remote Manager.

### **rpc: f : Unable to initialize security. Aborting**

The Remote Manager was unable to find a rights identifier in the UAF.

*Solution:* Create the rights identifier.

### **sec: e : Failure obtaining uaf info for ACMS\$SNMP**

If the SNMP interface is enabled, the ACMS\$SNMP account must exist. Otherwise, it can perform no operations. If the account exists, it must be granted at least one of the following rights identifiers: ACMS\$MGMT\_READ, ACMS\$MGMT\_WRITE, ACMS\$MGMT\_OPER.

*Solution:* Either disable the SNMP interface (`[$ACMSCFG,ACMSMGR] SET INTERFACE/INTERFACE=SNMP/STATE=DISABLED`), or create the ACMS\$SNMP account and grant it one of the rights.

### **sec: e : MGMT\$L\_ACMS\$MGMT\_READ Rights identifier not found in rights db!**

The Remote Manager was unable to find the rights identifier in the UAF.

*Solution:* Create the rights identifier.

### **sec: f : ACMS\$SNMP user has been granted no rights.**

If the SNMP interface is enabled, the ACMS\$SNMP account must be granted at least one of the following rights identifiers: ACMS\$MGMT\_READ, ACMS\$MGMT\_WRITE, ACMS\$MGMT\_OPER. Otherwise, the account cannot perform any operations. If it is not granted any rights identifiers, the thread will not start.

*Solution:* Either disable the SNMP interface (`[$ACMSCFG,ACMSMGR] SET INTERFACE/INTERFACE=SNMP/STATE=DISABLED`), or grant one of the rights to the ACMS\$SNMP account.

**snmp: e : Terminating....**

This is a general error that simply reports that the thread is exiting. Look in the log file for the reason the thread is exiting. If there are no other error messages, look in `SYSS$ERRORLOG:ACMS$MGMT_SERVER.OUT`.

**snmp: f : Internal Initialization failed, exiting...**

This is a general error that simply reports that the thread is exiting. Look in the log file for the reason the thread is exiting. If there are no other error messages, look in `SYSS$ERRORLOG:ACMS$MGMT_SERVER.OUT`.

**snmp: w : An esnmp error has occurred: -1**

This message, if followed by termination of the SNMP thread, usually indicates that SNMP has not been set up properly on the node.

*Solution:* Configure and enable the SNMP interface. Restart TCP/IP and then restart the Remote Manager.

If this message is received, but is not followed by termination of the SNMP thread, the SNMP interface was able to recover from this error and there is no action that must be taken.

**snmp: w : An esnmp error has occurred: -5**

This is a warning message that refers to a problem communicating with the SNMP master agent. These errors usually are recoverable and the SNMP interface continues to work. In general, you can ignore this message.

However, frequent occurrences of this error may be attributable to a busy system and may indicate a need to modify one or more of the following parameters: `snmp_agent_time_out`, `snmp_are_you_there`, `snmp_sel_time_out`.

## 2.4.3. Problems with the ACMSMGR Utility

ACMSMGR problems typically fall into two categories:

- ACMSMGMT-W-NOCLNT\_ATTACH messages (see Section 2.4.3.1)
- ACMSMGR hangs (see Section 2.4.3.2)

### 2.4.3.1. ACMSMGMT-W-NOCLNT\_ATTACH Messages

ACMSMGR can display the following message:

```
%ACMSMGMT-W-NOCLNT_ATTACH, Cannot create client for node NODE\NOCLNT_ATTACH
```

This message usually is followed by these messages:

```
%ACMSMGMT-E-NOCLIENTS, No clients created, cannot continue
%ACMSMGMT-E-FAIL, Operation failed
```

These messages usually are returned when the Remote Manager is not running on the target node. Possible reasons for this include:

- The Remote Manager is not started.

*Solution:* Start the Remote Manager as follows:

```
$ @SYS$STARTUP:ACMS$MGMT_STARTUP
```

- The Remote Manager is not fully initialized. Complete initialization of the Remote Manager may take several seconds.

*Solution:* Wait several seconds and then reissue the command that resulted in this error.

- The node name is incorrect.

*Solution:* Double-check the spelling of the node name in the /NODE qualifier or in the ACMS \$MGMT\_SERVER\_NODE logical.

### 2.4.3.2. ACMSMGR Hangs

ACMSMGR hangs are generally the result of a problem with the Portmapper or the Remote Manager. To verify that the Remote Manager has connected to the Portmapper, issue the following commands on the node on which the Remote Manager is running:

```
$ TCPIP
TCPIP> SHOW PORTMAPPER
```

If the Remote Manager has connected, you will see a display similar to the following:

Program Number	Version	Protocol	Port-number	Process	Service-name
000186A0 (	100000)	2	TCP	111 20407E5E	PORTMAPPER
000186A0 (	100000)	2	UDP	111 20407E5E	PORTMAPPER
20000099 (	536871065)	1	UDP	1023 20408675	
20000099 (	536871065)	1	TCP	1023 20408675	

If the bottom two lines are missing (program number 20000099, version 1), then the Remote Manager is not connected to the Portmapper. Either the Remote Manager is not started or has terminated, or the RPC interface is not enabled.

If no lines are displayed (that is, if a “record not found” message is displayed), the Portmapper is not started. Refer to Section 2.2 for more information.

*Solution:* Correct the problem with the Remote Manager or the Portmapper.



# Chapter 3. Using the Remote Manager to Manage ACMS

This chapter describes how to prepare and run the ACMS Remote Manager web agent.

## 3.1. Overview of the Remote Manager Web Agent

With the Remote Manager web agent, system managers can use their web browser to monitor and tune remote ACMS systems. The ACMS for OpenVMS Alpha Development and Run-time kits include the Remote Manager Hyper-Media Management Object (HMMO), which is integrated into the VSI web-based enterprise management (WBEM) environment. Known as the Remote Manager web agent, this object functions as a Remote Manager client through the ONC RPC interface.

---

### Note

ACMS HMMO will work only with Insight Management Agents using the ELM HTTP/HTTPS server. It will not work with versions of Insight Management Agent using the System Management Homepage as the HTTP/HTTPS server.

---

The Remote Manager web agent environment consists of the following host systems:

- **Web client** – One or more local systems running a web browser that supports Java plug-ins, JavaScript, and Cascading Style Sheets (CSS).
- **Web server** – An OpenVMS Alpha system where the web agent (ACMS\$MGMT\_HMMO) and WBEM management server (WBEM\$SERVER) processes are running. This system serves the ACMS Remote Management web page and handles all communication between the web client and Remote Manager server systems.
- **Remote Manager server** – One or more OpenVMS Alpha or I64 systems where Remote Manager server processes (ACMS\$MGMT\_SVR) are running. The ACMS information displayed on the web agent home page is a result of executing ACMSMGR commands on the Remote Manager servers.

As shown in Figure 1.1, the Remote Manager web agent (ACMS\$MGMT\_HMMO) relies on the WBEM management server (WBEM\$SERVER) to relay data to and from the web browser. The web agent uses its internal web server to connect to the ACMS Remote Management page. All command input is then relayed to Remote Manager server through the HMMO.

## 3.2. Remote Manager Web Agent Setup

Before you begin, you must have already installed OpenVMS Alpha Version 8.2 on the web server system. Also, ensure that all web client systems are running one of the currently supported web browsers. See the *VSI ACMS for OpenVMS Software Product Description* (SPD 25.50.xx) for a list of the currently supported web browsers.

Once the OpenVMS Alpha software is installed, perform the following steps to set up the Remote Manager web agent on the web server system:

- Install the Remote Manager web agent software (Section 3.2.1)

- Install the VSI Management Agents for OpenVMS software (Section 3.2.2)
- Assign additional rights identifiers (Section 3.2.3)
- Start the web agent (Section 3.2.4)
- Enable access to Remote Manager hosts (Section 3.2.5)

### 3.2.1. Install the Remote Manager Web Agent Software

The Remote Manager web agent software is bundled with the ACMS for OpenVMS Alpha Run-time and Development kits. To install the web agent software, choose to install the WBEM-related files component of either kit.

This section contains excerpts from an ACMS Development kit installation. Refer to the *VSI ACMS Version 5.0 for OpenVMS Installation Guide* for detailed information about the entire ACMS installation procedure.

1. Run the VSI ACMS for OpenVMS Alpha 5.0 installation procedure for either the ACMS Run-time or Development kit, in as described in Section 3.2.1 of the *VSI ACMS Version 5.0 for OpenVMS Installation Guide*. For example:

```
$ @SYS$UPDATE:VMSINSTAL ACMSDEVA_050 MTA0: OPTIONS N,AWD=DISK1
OpenVMS AXP Software Product Installation Procedure V8.2
```

```
It is 22-JUN-2001 at 11:00.
```

```
Enter a question mark (?) at any time for help.
```

2. A series of product-specific questions are displayed that prompt you to choose the appropriate installation options. Answer the following prompts accordingly:

```
* Do you want the full ACMS installation [NO]? N
* Do you want to install the ACMS component software [YES]? N
* Do you want to install the WBEM-related files for ACMS [YES]? Y
* Do you want to update the LSE environment for ACMS [YES]? N
```

The installation procedure then checks for prerequisite software and adequate disk space and lists a summary of the components to be installed, as follows:

```
CHECKING INSTALLATION PREREQUISITES
```

```
-----
      (required and optional software checked)
      (product licenses checked)
      (disk space checked)
```

```
ACMS PREVIOUS INSTALLATION
```

```
-----
      (previous installation of ACMS is compatible with current
      installation)
```

```
ACMS WBEM CHECK
```

```
-----
SUMMARY OF THIS ACMS INSTALLATION
```

```
-----
      The following steps will be taken to complete this installation:
      o WBEM environment will be updated for ACMS
```

The rest of the installation will take approximately 7 minutes. Note that this time is heavily dependent your system load, hardware and kit media. The time mentioned was measured on a stand-alone DEC 3000 (Alpha) system with a disk-resident kit. Your time may vary.

3. When prompted to continue the installation, answer YES. The procedure enters the ACMS WBEM Setup phase.
4. The WBEM setup procedure (SYS\$STARTUP:ACMS\$WBEM\_SETUP.COM) is then invoked, which creates or updates the ACMS\$WBEM account and creates the necessary directories and web agent files.

Do one of the following:

- If the account does not exist, you are prompted to supply a UIC and password for the account, as follows:

```
The ACMS$WBEM account used to execute ACMSMGR WBEM commands is not
available.
You must supply a UIC and password for this account so that it can be
created.
Please enter the UIC for the ACMS$WBEM account, in the form
 [ggggg,nnnnn]
UIC: [320,525]
```

```
Please enter a password of at least 8 characters, using only
the following characters: ABCDEFGHIJKLMNOPQRSTUVWXYZ0123456789$_
Password:
Verification:
```

Enter the appropriate UIC and password. The ACMS\$WBEM account is then created and assigned the ACMS\$MGMT\_READ rights identifier.

- If the account already exists, a list of the rights identifiers currently assigned to the account are displayed, as follows:

```
*****
*                               ACMS WBEM Setup                               *
*****
Checking for user account ACMS$WBEM
Identifier for ACMS$MGMT_READ exists in RIGHTSLLIST
Identifier for ACMS$MGMT_WRITE exists in RIGHTSLLIST
Identifier for ACMS$MGMT_OPER exists in RIGHTSLLIST
Identifier for ACMS$MGMT_SYSUPD exists in RIGHTSLLIST
```

The account ACMS\$WBEM exists.

The identifiers on the account ACMS\$WBEM are

Identifier	Value	Attributes
ACMS\$MGMT_READ	%X8001012E	
ACMS\$MGMT_WRITE	%X8001012F	
ACMS\$MGMT_OPER	%X80010130	
ACMS\$MGMT_SYSUPD	%X800101DB	

```
Do you wish to reset the account ACMS$WBEM to the default values
[N] ? y
```

You can choose to reset the identifiers at this time by answering YES.

The setup procedure then completes by creating the following directories and files on the web server system:

The ACMS WBEM setup has completed.  
The following files were copied:

```
To SYS$SYSROOT:[WBEM]
    ACMS$MGMT_HMMO.EXE
    RUN_ACMS_HMMO.COM
    STOP_ACMS_HMMO.COM

To SYS$SYSROOT:[WBEM.WEB.IM.ACMSHMMO.ENG]
    ACMS.CSS
    ACMSHMMO.JS
    ACMSMENUTREE.JAR
    ACMS_BANNER.HTML
    ACMS_INDEX.HTML
    ACMS_MENU.HTML
    ACMS_OUTPUT.HTML

To SYS$SYSROOT:[WBEM.WEB.IM.ACMSHMMO.IMAGES]
    ACMSHMMO.GIF
    HPLOGO.GIF
    WEBBUM.GIF

To SYS$COMMON:[SYSLIB]
    ACMS$TRACE_SHR.EXE

You may wish to purge these directories.
```

Once the ACMS installation is complete, download and install the VSI Management Agent for OpenVMS software, as described in the next section.

## 3.2.2. Install the VSI Management Agents for OpenVMS Software

If you have not already installed the VSI Management Agents for OpenVMS software, do so now. You can download this software from the web page listed in Section 3.1.

Follow the associated instructions to copy, unpack, and install the appropriate VSI Management Agents for OpenVMS PCSI kit. Once the software is installed, issue the following command to start the management agent process:

```
$ SET DEFAULT SYS$SPECIFIC:[WBEM]
$ @WBEM$RUN_WEBSERVER.COM
```

Note that the WBEM server (WBEM\$SERVER) is the only process started by this procedure. None of the other Management Information Base (MIB) processes included in the WBEM kit (such as, WBEM\$CPQHOST) are used by the Remote Manager agent. If you plan to use software on this system that relies on the MIB processes, run the WBEM\$STARTUP.COM procedure, as described in the WBEM installation material.

## 3.2.3. Assign Additional Rights Identifiers

The installation procedure automatically grants the ACMS\$MGMT\_READ rights identifier to the ACMS\$WBEM account when it is created. This enables all SHOW commands to be executed from

the web agent. In order to enable all other non-read operations (such as SAVE, SET, START, STOP, RESET, ADD, and DELETE), grant one or more of the following rights identifiers to the ACMS \$WBEM account:

- ACMS\$MGMT\_WRITE
- ACMS\$MGMT\_OPER
- ACMS\$MGMT\_SYSUPD

See Section 4.4.2 for more information on the use of rights identifiers.

### 3.2.4. Start the Remote Manager Web Agent Process

Enter the following command to start the Remote Manager web agent process:

```
$ SUBMIT/NOTIFY/LOG=SYS$SYSROOT:[WBEM]/QUEUE=queue-name -
_ $ /USER=ACMS$WBEM SYS$SPECIFIC:[WBEM]RUN_ACMS_HMMO.COM
```

where *queue-name* is a valid OpenVMS batch queue. If the process is already running, this command restarts the process.

### 3.2.5. Enable Access to Remote Manager Hosts

In order for the Remote Manager web agent to access a Remote Manager server system, the logical ACMS\$MGMT\_ALLOW\_PROXY\_ACCESS on the host system must be set to a value of 1, which enables proxy access.

Also, an ACMS proxy entry for the ACMS\$WBEM account is required. For example, the following proxy entry grants the user ACMS\$WBEM access to the local host from any known system:

```
$ MCR ACMSUDU
UDU>SHOW /PROXY *::ACMS$WBEM
Remote User: *::ACMS$WBEM                Local User: ACMS$WBEM
```

The rights identifiers on the local ACMS\$WBEM account control the level of access allowed on the host system.

---

#### Note

Even if the Remote Manager is running on the same node as the web agent, it is still considered a remote host and the requirements above still apply.

---

### 3.2.6. Stop the Remote Manager Web Agent

Use the following command to stop the web agent process:

```
$ @SYS$SPECIFIC:[WBEM]STOP_ACMS_HMMO.COM
```

If you also want to stop the WBEM server process, enter the following command:

```
$ @SYS$SPECIFIC:[WBEM]WBEM$STOP_WEBSERVER.COM
```

## 3.3. Using the Remote Manager Web Agent

The following sections describe how to access and use the Remote Manager web agent interface.

### 3.3.1. Accessing the ACMS Remote Management Web Page

From a browser on the web client system, enter the following URL to connect to the web server system:

```
http://server-host:2301/acmshmmo/eng/acms_index.html
```

where *server-host* represents the address of the OpenVMS Alpha system on which the web agent software is running. This address can be expressed in any of the following forms:

```
node (node name)
node.company.com (URL)
165.112.94.78 (IP address)
```

The ACMS Remote Management page is displayed, similar to the figure below.

**Figure 3.1. Remote Manager Web Agent Page**

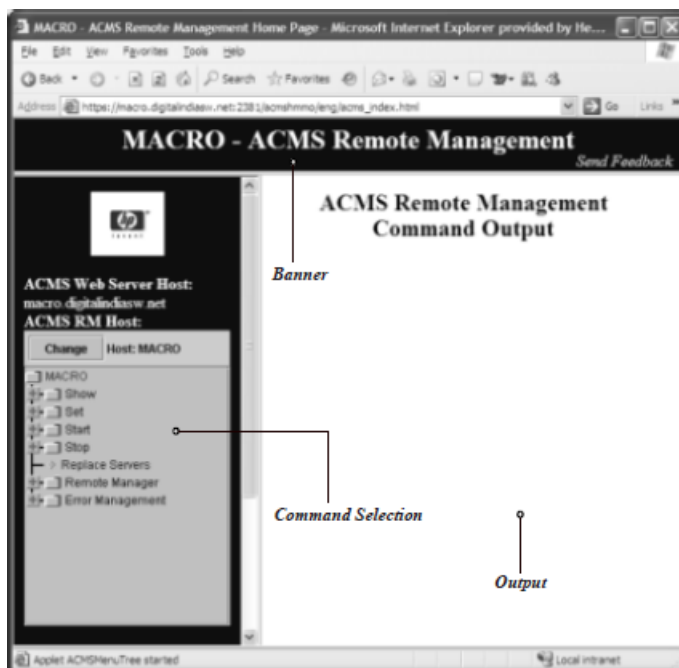

This page consists of the following frames:

#### Banner frame

Displays the application name as well as the name of the web server system. This frame also contains a link that you can use to send feedback about the web agent directly to VSI.

#### Command Selection frame

Displays a tree that contains selections representing the various ACMSMGR commands. The items in this tree are grouped by common command verbs (such as, SHOW and SET) or by object

(such, as Remote Manager). This frame also contains a series of links to pertinent VSI WBEM and ACMS information, such as to the HTML version of this guide.

#### Output frame

Displays the results of the selected command. Brief instructions on how to interact with the data in this frame are displayed along with the related output and status messages (if any).

### 3.3.2. Conventions

The web agent uses color and font highlighting to indicate the different states and types of data displayed in the output frame. The default conventions are described in the table below. Note, however, that you can change these conventions as described in the following section.

**Table 3.1. Remote Manager Web Agent Conventions**

Text appearing in...	Indicates...
White with teal or blue background	Active and stored values that can be changed. To set a value, single click on the item. (Set commands)
Teal italics	Dynamic configuration fields. (Show commands)
Gray	Inactive data; old process data that is still available will be displayed. The node name is also prefixed with an asterisk, similar to ACMSMGR displays. (Show commands)
Red	Warning or error messages. (All)
Blue	Disabled collection state. Data displayed for the related class may not be current. (Show commands)

### 3.3.3. Customizing the Display

The Remote Management web page relies on a cascading style sheet (CSS) to manage its formatting. Based on the CSS level 2 specification (CSS2) from the World Wide Web Consortium (W3C), the ACMS.CSS file functions as a template for information displayed in the output frame.

If you are familiar with CSS files, you can customize the formatting of information in the output frame by editing the file ACMS.CSS located in SYSSYSROOT: [WBEM.WEB.IM.ACMSHMMO.ENG].

For example, to remove the background image in the output frame, open the CSS file and search for the following statement:

```
BODY {background-color: white; background-image:
url(/acmshmmo/images/webbum.gif); color: black;}
```

Replace this statement with the following:

```
BODY {background-color: white; color: black;}
```

To learn more about CSS files or the CSS2 specification, visit the W3C web site for the latest information and resource listings:

<http://www.w3.org/Style/CSS>

---

## Note

Each browser may interpret style sheet properties differently. Be aware that slight variations in format may occur depending upon the browser that you use.

---

### 3.3.4. Selecting the Remote Manager Host

When you first access the ACMS Remote Management web page, the name of the web server is displayed as the Remote Manager host.

To choose a different Remote Manager host, click the Change button in the command selection frame. The Select Host popup window is displayed, similar to the figure below.

**Figure 3.2. Select Host**

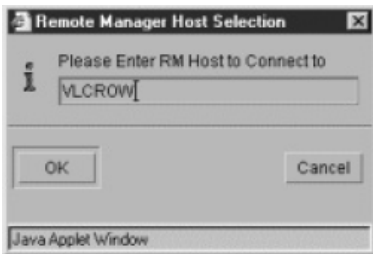

Enter the name of the Remote Manager host, and click OK. Note that if you enter a URL or IP address, only the short form of the name is displayed in the command selection frame.

## 3.4. Issuing Remote Manager Commands

The Remote Manager web agent interface provides detailed usage instructions on each page displayed within the output frame. Therefore, the following sections are only intended to provide a brief overview of issuing the most common Remote Manager commands with the web agent.

The Remote Manager web agent interface provides you with much of the same capability as ACMSMGR in managing ACMS systems. The main functional differences are that with the web agent:

- You cannot view TRAP information.
- There is no equivalent to the SHOW LOG/LOCAL and SHOW ERROR/LOCAL commands.
- You can only connect to one Remote Manager host system per window.

You can quickly reissue any web agent command using the **Refresh** (or **Reload**) option of your browser to reload the page in the output frame. To save frequently issued commands, bookmark the page in the output frame.

### 3.4.1. Using Show Commands

To display information about an ACMS entity or object:



1. In the command selection frame, click **Show** to expand the list of valid entities and Remote Manager objects.
2. Click on the appropriate entity (such as, **TSC**) or object (such as, **Process**). If you selected an entity, click on the appropriate type of information to display (such as, **Config**), and choose the scope of display (such as, **Brief/Stored**).

The results of the command are displayed in the output frame, similar to the figure below. Note that all dynamic data is displayed in italics.

**Figure 3.3. Show TSC**

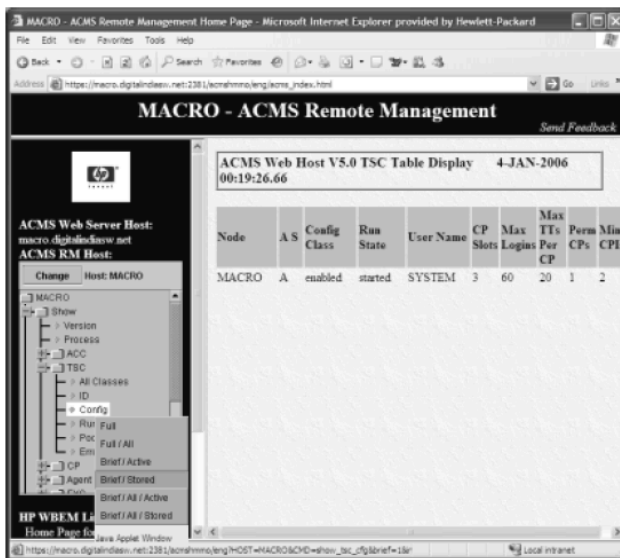

### 3.4.2. Using Set Commands

To change information related to an ACMS entity or Remote Manager object:

1. In the command selection frame, click **Set** to expand the list of valid entities and Remote Manager objects.
2. Click on the appropriate entity (such as, **ACC**) or object (such as, **Remote Manager > Collection**). If you selected an entity, click on the appropriate type of information you want to change (such as, **ACMSGEN**).

The available values are displayed in the output frame, similar to the figure below. Note that any active and stored data that can be changed is displayed reverse highlight.

Figure 3.4. Set ACC

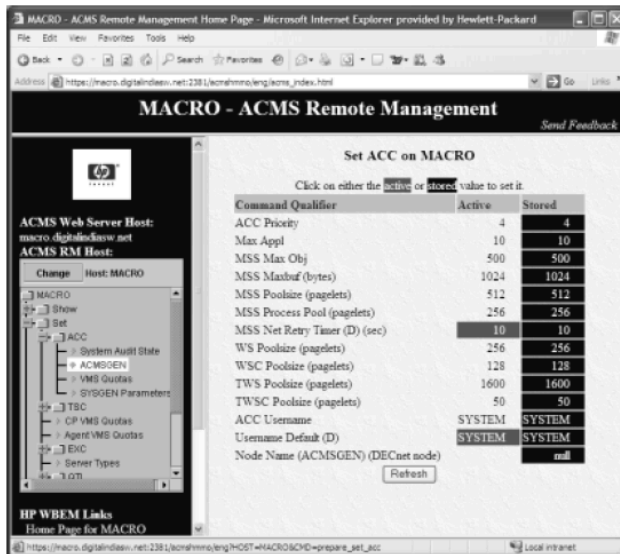

3. Move the cursor over the value you want to change until the link cursor appears, and then click on the value. A popup window is displayed prompting you for a new value.
4. Enter the new value in the popup window, and click **OK**.

Note that you can update the values displayed in the output frame at any time by clicking the **Refresh** button.

### 3.4.3. Using Start and Stop Commands

To start or stop an ACMS object, such as an application (EXC):

1. In the command selection frame, click **Start** or **Stop** to expand the list of objects.
2. Click on the appropriate object (such as, **Remote Manager > Collection**).

Except for System, the command is executed as soon as it is selected. If you chose **Start** or **Stop System**, additional choices are displayed in the output frame.

3. Click on the appropriate check boxes to set or unset one or more values, and click the **Start SYSTEM** or **Stop SYSTEM** button.

### 3.4.4. Using Add and Delete Commands

To add or delete a Remote Manager object, such as an error filter:

1. In the command selection frame, click on the appropriate entry, either **Error Management** or **Remote Manager**.
2. Click on the subentries until you reach the item you want to add or delete (such as, **Add Filter**).

A form with related parameter information is displayed, similar to the figure below.

Figure 3.5. Add Error Filter

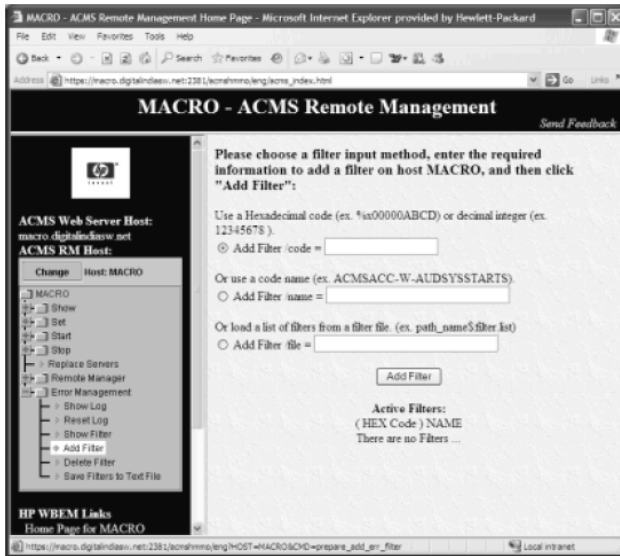

3. Complete form and click **Add** or **Delete**.

## 3.5. Troubleshooting the Remote Manager Web Agent

- **WBEM Home Page does not display the ACMS Icon**

ACMS HMMO is not registered with the WBEM\$SERVER process. After starting the WBEM server with the following command:

```
$ @SYSS$SPECIFIC:[WBEM]WBEM$RUN_WEBSEVER.COM
```

You may need to delay starting the ACMS HMMO until the WBEM\$SERVER process is in the HIB state. If the ACMS HMMO is started too soon it may not register with the WBEM\$SERVER. The SYSS\$SPECIFIC:[WBEM]WBEM\$RUN\_WEBSEVER.COM must be run prior to running SYSS\$SPECIFIC:[WBEM]RUN\_ACMS\_HMMO.COM.

- **WBEM Home Page does not display**

If you access the WBEM Home Page at `http://host_name:2301/`, and the page does not display, it may be that the WBEM\$SERVER is not started. Another possibility is that the ACMS \$MGMT\_HMMO process was started prior to the WBEM\$SERVER process. To ensure proper startup, stop both processes and then restart them in the correct order.

- **Remote Manager web page displays, but remote commands fail.**

This indicates that the Remote Manager web agent cannot connect to the specified Remote Manager server host. If all commands fail, ensure that the Remote Manager server process is running on the host system and that access to it has been properly setup (as described in Section 3.2.5. If some commands work and others fail, the ACMS\$WBEM account may not have the required rights identifier; see Section 3.2.3.

- **Page Refresh or Reload does not update the output frame.**

This behavior is browser dependent. To refresh the information displayed in the output frame, move the cursor inside the frame to specifically refresh or reload the information within it.

### 3.5.1. Reporting Problems

If the ACMS\$MGMT\_HMMO process crashes, the following files will contain any error information that was available: SYSS\$SPECIFIC:[WBEM]ACMS\$MGMT\_HMMO.LOG;\* SYSS\$SPECIFIC:[WBEM]ACMS\$MGMT\_HMMO.ERR;\*

If there are any new dump files you may want to examine the file to locate the problem source. SYSS\$SPECIFIC:[WBEM]\*.DMP;\*

If the problem is with WBEM\$SERVER process, send the dump file to your VSI support representative. If the problem is with the ACMS HMMO process, please have the following files ready for analysis in addition to a procedure that reproduces the situation:

SYSS\$SPECIFIC:[WBEM]ACMS\$MGMT\_HMMO.LOG;\*

SYSS\$SPECIFIC:[WBEM]ACMS\$MGMT\_HMMO.ERR;\*

SYSS\$SPECIFIC:[WBEM]\*.html;\*

SYSS\$SPECIFIC:[WBEM]\*.txt;\*

SYSS\$SPECIFIC:[WBEM]SYS\$OUTPUT.\*;

SYSS\$SPECIFIC:[WBEM]\*.DMP;\*

# Chapter 4. Managing the Remote Manager

This chapter describes how to manage the ACMS Remote Manager.

## 4.1. Overview

The ACMS Remote Manager runs on the same node as the ACMS run-time system but runs independently of it. The Remote Manager may be started and stopped at any time without affecting the ACMS run-time system. Similarly, the ACMS system can be started and stopped at any time without affecting the Remote Manager process. Remote management can be performed only on nodes where the Remote Manager has been started.

ACMS system managers configure the Remote Manager process (for example, which interfaces are enabled, what alarms to send) using a combination of the ACMSCFG utility (which provides initial configuration settings at process startup) and the ACM SMGR utility (to change settings once the process has started). Management consoles that support SNMP can also be used to configure and manage the Remote Manager.

Before the Remote Manager process can communicate with external entities, either SNMP or RPC must be configured and running on the appropriate nodes. See the VSI ACMS Version 5.0 for OpenVMS Installation Guide for information about configuring and starting SNMP and RPC.

## 4.2. Configuring Remote Manager Startup

Before the Remote Manager is started, the **configuration file** should contain the appropriate settings. Both the ACMS run-time system and the Remote Manager read the configuration file during startup. If the ACMS Central Controller (ACC) process cannot read the configuration file when starting up, it uses default values. If the Remote Manager cannot read the configuration file when starting up, it logs an error and exits. By default, the configuration file is stored in SYSSYSTEM:ACMS \$MGMT\_CONFIG.ACM. This location can be changed using the systemwide logical ACMS \$MGMT\_CONFIG. Use the ACMSCFG utility to change values in this file. The ACMSCFG utility allows ACMS system managers to set:

- The interfaces to be started
- Data-collection options
- Remote Manager run-time parameters
- SNMP traps

The configuration file is created during postinstallation with a set of default values. ACMS system managers should review these settings prior to starting the Remote Manager to determine whether the settings are appropriate for the node on which the process will run. Use the ACMSCFG SHOW commands as follows to display the settings:

```
$ ACMSCFG SHOW INTERFACE
$ ACMSCFG SHOW COLLECTION
$ ACMSCFG SHOW PARAMETER
$ ACMSCFG SHOW TRAP
```

## Note

Changes made to the ACMSCFG file are not automatically reflected in the running system. The ACMSCFG file is read during Remote Manager and ACMS system startup only. The Remote Manager process must be restarted in order for configuration file changes to the Parameter, Interface, and Trap tables to become active. The ACMS run-time system must be restarted in order for configuration file changes to the Collection table to become active. After the Remote Manager process has been started, you can use the ACMSMGR utility to make dynamic changes to the active system.

---

### 4.2.1. How to Run the ACMSCFG Utility

The ACMSCFG utility is a DCL command line tool that is invoked using a foreign command. The ACMSCFG utility accepts a number of command line arguments that determine what operations it should perform. The basic syntax for running the ACMSCFG utility is as follows:

```
ACMSCFG verb object qualifier
```

For example, to display the current data collection settings, you would use the following command:

```
$ ACMSCFG SHOW COLLECTION
```

You can get help on the available ACMSCFG commands and their syntax using the following command:

```
$ ACMSCFG HELP
```

You can define your own foreign command by using the following DCL command:

```
$ MYCOMMAND ::= $SYS$SYSTEM:ACMS$MGMT_CONFIG_CMD
```

If you do this, you would substitute MYCOMMAND for ACMSCFG in the preceding examples.

When the ACMSCFG utility is started, it attempts to locate the ACMS\$MGMT\_CONFIG.ACM file by translating the logical name ACMS\$MGMT\_CONFIG. If that attempt fails, it looks in the default location, SYSSYSTEM:ACMS\$MGMT\_CONFIG. If that lookup fails, ACMSCFG asks the user whether to create a new file. New files are created with default values in the directory that the logical name ACMS\$MGMT\_CONFIG translates to. If the logical name is not defined or does not include a directory specification, the default directory location is the current directory.

### 4.2.2. Displaying Current Values

Current ACMSCFG values can be displayed using the SHOW command, as follows:

```
ACMSCFG SHOW object
```

Valid SHOW objects are:

- Collection
- Control
- Interface
- Parameter

- Trap

The values for each object type correspond directly to fields in management configuration tables. These tables are discussed in Chapter 9.

The following is an example SHOW command and its output:

```
SPARKS> ACMSCFG SHOW COLLECTION
```

Entity		Collect	Collect	Storage		
Type	Entity Name	Class	State	Storage Location	State	Interval
*	*	id	enabled	acms\$mgmt_snapshot	enabled	3600
*	*	config	enabled	acms\$mgmt_snapshot	disabled	3600
*	*	error	enabled	acms\$mgmt_snapshot	disabled	300

### 4.2.3. Changing Values

ACMSCFG values can be changed using one of three verbs:

- ADD

The ADD verb is used to add rows for the following objects:

- Collection
- Trap

Example:

```
$ ACMSCFG ADD COLLECTION/ENTITY=*/NAME=*/CLASS=RUNTIME
```

- DELETE

The DELETE verb is used to delete rows for the following objects:

- Collection
- Trap

Example:

```
$ ACMSCFG DELETE COLLECTION/ENTITY=*/NAME=*/CLASS=RUNTIME
```

- SET

The SET verb is used to add rows for the following objects:

- Collection
- Interface
- Parameter
- Trap

Example:

```
$ ACMSCFG SET COLLECTION/ENTITY=*/NAME=*/CLASS=RUNTIME/  
COLL_STATE=ENABLED
```

Each object has unique qualifiers that determine which values are to change. Qualifiers are either **mandatory** or **optional**. **Mandatory** qualifiers have no default and must be specified by the user. **Optional** qualifiers have default values and do not have to be specified. See Chapter 10 for a complete description of the syntax for each command and the qualifiers they support.

## 4.3. Starting and Stopping the Remote Manager

The following information discusses starting and stopping the ACMS Remote Manager.

### 4.3.1. Remote Manager Startup

The Remote Manager is started as a detached process using the command procedure SYS \$STARTUP:ACMS\$MGMT\_STARTUP, as follows:

```
$ @SYS$STARTUP:ACMS$MGMT_STARTUP
```

You should run this file from the SYSTEM account during system startup. You can run the file either before or after the ACMS run-time system has been started. Alternatively, you can run it at any time from a privileged account.

During process startup, the Remote Manager reads the ACMSCFG file (located in SYS \$SYSTEM:ACMS\$MGMT\_CONFIG.ACM or wherever the ACMS\$MGMT\_CONFIG logical points). If the file cannot be found and opened, the Remote Manager will not start.

The Remote Manager writes errors to the ACMS\$MGMT\_LOG file. This is a binary file that can be displayed using the ACMSMGR utility, as follows:

```
$ ACMSMGR SHOW LOG
```

The ACMSMGR utility generally performs operations on remote nodes. If the Remote Manager fails to start, it will not be accessible remotely. You will need to log in to the node on which it failed to start, and issue the following command:

```
$ ACMSMGR SHOW LOG/LOCAL
```

This command instructs the ACMSMGR utility to read the log file directly, bypassing the Remote Manager. See Chapter 11 for a complete description of the ACMSMGR utility, commands, and command syntax.

In addition to writing messages to the ACMS\$MGMT\_LOG file, the Remote Manager writes messages to SYSS\$OUTPUT if it cannot access the log file. You can have all messages written to SYS \$OUTPUT by invoking the startup procedure with the LOG\_TO\_SYSOUT parameter, as follows:

```
$ @SYS$STARTUP:ACMS$MGMT_STARTUP LOG_TO_SYSOUT
```

The ACMS\$MGMT\_STARTUP procedure redirects SYSS\$OUTPUT for the Remote Manager to a file called ACMS\$MGMT\_SERVER.OUT in the SYSS\$ERRORLOG directory.



## 4.3.2. Remote Manager Shutdown

The Remote Manager is stopped using the `ACMSMGR STOP MANAGER` command, which has the following syntax:

```
ACMSMGR STOP MANAGER /NODE=node-name
```

The `/NODE` qualifier can be omitted if the `ACMS$MGMT_SERVER_NODE` logical is defined. If the `/NODE` qualifier is provided, it overrides the `ACMS$MGMT_SERVER_NODE` logical.

The Remote Manager can be stopped independently of the ACMS run-time system. Stopping the Remote Manager has no effect on the running ACMS system. Note, however, that simply stopping the Remote Manager does not stop any active data collections. Data collections can be stopped only by using `ACMSMGR` commands, or from an SNMP management console that has access to the Remote Manager.

Note also that prior to issuing this command, the user must either have logged in to the Remote Manager, or the user must have a valid proxy (and proxy access must have been enabled). Regardless of how access is gained, the user must hold the `ACMS$MGMT_OPER` rights identifier on the node the Remote Manager is running in order to stop it. See Section 4.4 for a description of how to log in to the Remote Manager.

The `ACMSMGR STOP MANAGER` command executes asynchronously of the actual shutdown. That is, the command will complete (control will return to the user) before the shutdown has completed.

If the Remote Manager fails to shut down, it can be stopped by using the `DCL` command `STOP/ID`, which has the following syntax:

```
STOP/ID=pid
```

Determine the PID of the Remote Manager using the `DCL` command `SHOW SYSTEM`, and then look for the process named `ACMS$MGMT_SVR`.

## 4.4. Logging In to the Remote Manager

The Remote Manager requires that each client is authenticated and that each access attempt is authorized.

### 4.4.1. Authentication

Authentication can be performed in one of two ways: either through an explicit login (using a valid OpenVMS user name and password) or through a valid ACMS proxy account.

The exception to this rule is SNMP access, which is controlled by the presence of the `ACMS$SNMP` account in the local rights database. Authentication for external entities that communicate with the Remote Manager through the SNMP protocol is allowed only when a valid OpenVMS account exists for the user `ACMS$SNMP`. If this account exists and is not disusered, the user is considered to be an authentic user. Authorization for SNMP users is treated the same as for any other user — by OpenVMS rights identifier. See Section 4.4.2 for more information about authorization.

All access for an interface can be disabled by disabling the interface itself, either through the `ACMSCFG` utility prior to management startup, or through the `ACMSMGR` utility after Remote Manager startup.

The total number of users that can be simultaneously logged in to the Remote Manager (regardless of authentication mechanism) is controlled by the Remote Manager parameter `MAX_LOGINS`, which can be modified by the Remote Manager. (This parameter is not the same as the `MAX_LOGINS` ACMS system parameter in `ACMSGEN`.) When the number of users currently logged in is equal to the value of this parameter, new logins are rejected until some users have logged out, or until their credentials have expired. You can set the initial value of `MAX_LOGINS` with the `ACMSCFG` utility. You can change the value of `MAX_LOGINS` dynamically (but nondurably) with the `ACMSMGR` utility.

Attempts to log in to the Remote Manager are recorded in the Remote Manager log file if the `security_audit_level` parameter is set for informational level logging (any odd value, up to and including F). By default, informational messages are not logged. See Section 4.7.1 for more information.

Use the `SHOW USER` command of the `ACMSMGR` utility to display a list of users currently logged in to the Remote Manager. (*Note:* You must be authenticated in order to issue this command.)

```
$ ACMSMGR SHOW USER
```

### 4.4.1.1. Logging In

Login is performed using the `ACMSMGR LOGIN` command, which has the following syntax:

```
ACMSMGR LOGIN /USER=user-name /PASSWORD=password /NODE=node-name
```

The `/USER` qualifier can be omitted if the `ACMS$MGMT_USER` logical is defined. If the qualifier is provided, it overrides the `ACMS$MGMT_USER` logical. If neither the logical nor the qualifier is present, the `ACMSMGR` utility prompts the user for the user name.

If the `/PASSWORD` qualifier is not present, the `ACMSMGR` utility prompts the user for the password. There is no logical name for the password.

The `/NODE` qualifier can be omitted if the `ACMS$MGMT_SERVER_NODE` logical is defined. If it is provided, it overrides the `ACMS$MGMT_SERVER_NODE` logical. If neither the qualifier nor the logical name is provided, no login is attempted.

For each node to which a user logs in, a **credentials file** is created, either in the current directory or in the directory pointed to by the logical name `ACMS$MGMT_CREDS_DIR`. The credentials file contains encrypted security information (password is not stored in the file) and can be used by subsequent executions of the `ACMSMGR` utility. Credentials are specific to the process that created them and cannot be used by other processes. Prior to creating a new credentials file, any old credential files for the process are deleted.

Once a user has logged in to the Remote Manager, the user's credentials are valid for the duration of the credentials lifetime period, as specified by the parameter `LOGIN_CREDS_LIFETIME`. You can set the initial value of `LOGIN_CREDS_LIFETIME` with the `ACMSCFG` utility. You can change the value of `LOGIN_CREDS_LIFETIME` dynamically (but nondurably) with the `ACMSMGR` utility.

Once a user's credentials have expired, the user must log in to the server again.

### 4.4.1.2. Proxy Accounts

Proxy access to the management server is supported if the logical name `ACMS$MGMT_ALLOW_PROXY_ACCESS` is defined on the Remote Manager node. The valid values for this logical name are: 1, T, t, Y, y, TRUE, and true. If the name is defined to be any other value or if the logical name is not defined, proxy access is disabled.

When proxy access is allowed, users do not need to explicitly log in to the Remote Manager with a user name and password, and no credentials file is created. See Section 4.4.1.1 for a description of how to log in with user name and password.

In order for a user to be granted proxy access, there must be an entry in the ACMSPROXY.DAT for the combination of node and user attempting access. See VSI ACMS for OpenVMS Managing Applications for more information. The first time a user attempts to access a management function without having first logged in using user name and password, the Remote Manager looks for a valid ACMS proxy. If one is found, the OpenVMS account specified by the proxy is used for authorization.

The Remote Manager maintains a cache of users who have been logged in by proxy. Records remain in the cache for the duration of the proxy credentials' lifetime, as specified by the PROXY\_CREDS\_LIFETIME parameter. You can set the initial value of PROXY\_CREDS\_LIFETIME with the ACMSCFG utility. You can change the value of PROXY\_CREDS\_LIFETIME dynamically (but nondurably) with the ACM SMGR utility. Proxy credentials are automatically refreshed when they expire.

## 4.4.2. Authorization

Authorization consists of ensuring that the user attempting access holds the appropriate rights identifier on the node they are attempting to access. There are three levels of access, each with its own identifier, as shown in Table 4.1.

**Table 4.1. Node Access Types and Rights Identifiers**

Access Type	Rights Identifier
Operate	ACMS\$MGMT_OPER
Read	ACMS\$MGMT_READ
Write	ACMS\$MGMT_WRITE

### 4.4.2.1. Read Access

Read access allows users to perform the following functions:

- Log in
- Log out
- Issue SHOW commands

### 4.4.2.2. Write Access

Write access allows users to issue the following commands:

- ADD
- DELETE
- SET

### 4.4.2.3. Operate Access

Operate access allows users to issue the following commands:

- REPLACE
- RESET
- START
- STOP

## 4.5. Starting and Stopping Interfaces

You can control which interfaces are started or stopped by using either the ACMSCFG utility prior to Remote Manager startup or the ACMSMGR utility after Remote Manager startup. The Remote Manager supports two interfaces:

- RPC

The RPC interface is used by the ACMSMGR utility, and also by any user-written programs based on the MGMT API. Most users will enable the RPC interface.

- SNMP

The SNMP interface is used by third-party system management packages to access ACMS management information. If no SNMP enabled packages are being used, this interface can safely be disabled.

Either the RPC or SNMP interface should always be enabled. If both are disabled, there is no way to communicate with the Remote Manager.

For a more complete discussion of the available interfaces and their attributes, see Section 9.7.

### 4.5.1. Using ACMSCFG to Enable or Disable Interfaces

Use the ACMSCFG utility to configure which interfaces should be enabled or disabled when the Remote Manager starts up. Either the SNMP or RPC interface should always be enabled. If both are disabled, there is no way to communicate with the Remote Manager.

Use the ACMSCFG SET INTERFACE command to enable or disable an interface. This command has the following syntax:

```
ACMSCFG SET INTERFACE /INTERFACE=interface-name /STATE=state
```

In this format:

- *interface-name* is one of the supported interfaces (SNMP or RPC).
- *state* is one of the following states: ENABLED or DISABLED.

Use the ACMSCFG SHOW INTERFACE command to determine the state of an interface in the configuration file:

```
$ ACMSCFG SHOW INTERFACE
```

### 4.5.2. Using ACMSMGR to Start or Stop Interfaces

Use the ACMSMGR utility to dynamically enable or disable an interface after the Remote Manager has already been started. As noted previously, at least one of either the SNMP or RPC interfaces

should always be enabled. If both are disabled, there is no way to communicate with the Remote Manager (for example, to shut it down or to enable an interface). Changes made with the ACMSMGR interface are not stored in the ACMSCFG file and are lost when the Remote Manager is stopped. Use the ACMSCFG utility to save changes to the ACMSCFG file.

An interface cannot disable itself. Since the ACMSMGR utility uses the RPC interface, it cannot be used to disable the RPC interface. To disable the RPC interface, either use the ACMSCFG utility and restart the Remote Manager, or use the SNMP interface.

Use the ACMSMGR SET INTERFACE command to disable the SNMP interface. The command has the following syntax:

```
ACMSMGR SET INTERFACE /INTERFACE=interface-name /STATE=state
```

In this format:

- *interface-name* must be SNMP.
- *state* is one of the following states: ENABLED or DISABLED.

Use the ACMSMGR SHOW INTERFACE command to determine the state of an interface:

```
$ ACMSMGR SHOW INTERFACE
```

## 4.6. Modifying Management Parameters

There are a large number of parameters that affect the internal processing of the ACMS Remote Manager. In general, most of these parameters will not need to be changed. However, you may need to alter some of these parameters in order to make the ACMS Remote Manager operate more efficiently or to meet your computing needs. You can modify these parameters using both the ACMSCFG and the ACMSMGR utilities.

For a more complete discussion of the available management parameters and their functions, see Section 9.9.

### 4.6.1. Using ACMSCFG to Modify Management Parameters

Use the ACMSCFG utility to set the values of management parameters when the Remote Manager starts up.

Use the ACMSCFG SET PARAMETER command to modify the value of a parameter. The command has the following syntax:

```
ACMSCFG SET PARAMETER /parameter-name=value
```

In this format:

- *parameter-name* is one of the management parameters listed in Section 9.9.
- *value* is the new value for the parameter.

Use the ACMSCFG SHOW PARAMETER command to determine the current value of the parameter in the configuration file:

```
$ ACMSCFG SHOW PARAMETER
```

## 4.6.2. Using ACM SMGR to Modify Management Parameters

Use the ACM SMGR utility to dynamically modify a management parameter after the Remote Manager has already been started. Not all parameters can be modified dynamically. Also, changes made with the ACM SMGR interface are not stored in the ACM SCFG file and are lost when the Remote Manager is stopped.

Use the ACM SMGR SET PARAMETER command to modify the value of a parameter. The command has the following syntax:

```
ACMSMGR SET PARAMETER /parameter-name=value
```

In this format:

- *parameter-name* is one of the dynamic management parameters listed in Section 9.9.
- *value* is the new value for the parameter.

Use the ACM SMGR SHOW PARAMETER command to determine the current value of the parameter in the configuration file:

```
$ ACM SMGR SHOW PARAMETER
```

## 4.7. Managing Log Files

The ACMS Remote Manager maintains an audit log of internally generated messages. The log is stored in a location determined by the logical name ACMS\$MGMT\_LOG. If the logical is not defined, the default location is in the default directory for the account under which the Remote Manager process runs.

Depending on the tracing levels specified, the size of this file will vary. It is strongly suggested that ACMS system managers monitor this file to ensure that it does not grow too large.

If the Remote Manager is unable to write to the audit log, it prints a message to file SYS \$ERRORLOG:ACMS\$MGMT\_SERVER.OUT and terminates. This can occur if logical name ACMS \$MGMT\_LOG is incorrectly defined, if the output device is full, or if the Remote Manager does not have sufficient privilege to write to the file.

### 4.7.1. Setting Audit Levels

Facilities within the Remote Manager write audit log messages based on the parameter settings, as shown in Table 4.2.

**Table 4.2. Audit Level Parameters**

Parameter	Function
DCL_AUDIT_LEVEL	Controls auditing for the DCL subprocess (used internally to modify the ACMS run-time system).
MGR_AUDIT_LEVEL	Controls auditing for the main Remote Manager process.

Parameter	Function
MSG_PROC_AUDIT_LEVEL	Controls auditing for the message processing thread (used internally to handle communications from ACMS processes).
PROC_MON_AUDIT_LEVEL	Controls auditing for the process monitor.
RPC_AUDIT_LEVEL	Controls auditing for the RPC interface.
SECURITY_AUDIT_LEVEL	Controls auditing for security access (authorization and authentication).
SNMP_AUDIT_LEVEL	Controls auditing for the SNMP interface.
TIMER_AUDIT_LEVEL	Controls auditing for the timer thread.

The value of each parameter determines what level of information is stored in the Remote Manager audit log. Table 4.3 shows the four levels of auditing and the integer value for each.

**Table 4.3. Auditing Levels and Their Values**

Auditing Level	Integer Value
Informational	1
Warning	2
Error	4
Fatal	8

Auditing values can be combined by logically ORing the integer values in order to have multiple levels of auditing in effect for a given facility. Table 4.4 shows the valid auditing values.

**Table 4.4. Auditing Level Combinations and Their Values**

Auditing Level	Value
None	0
Info	1
Warn	2
Info, Warn	3
Error	4
Info, Error	5
Warn, Error	6
Info, Warn, Error	7
Fatal	8
Info, Fatal	9
Warn, Fatal	A
Info, Warn, Fatal	B
Error, Fatal	C
Info, Error, Fatal	D
Warn, Error, Fatal	E
All	F

Parameter settings are stored in the ACMSCFG file and can also be modified dynamically using the ACMSMGR utility. For example, in order to specify that all messages and events generated by the security routines should be stored in the audit log, use the following command:

```
$ ACMSCFG SET PARAMETER/SECURITY_AUDIT_LEVEL=F
```

Alternatively, to dynamically modify an auditing level, use the following ACMSMGR utility command:

```
$ ACMSMGR SET PARAMETER/SECURITY_AUDIT_LEVEL=F
```

## 4.7.2. Displaying Audit Messages

Use the SHOW LOG command in the ACMSMGR utility to display Remote Manager audit messages. This command accepts a number of qualifiers, including a qualifier that identifies the node from which to get audit messages (/NODE) and a qualifier that specifies the beginning time of messages to display (/SINCE).

The following example shows how to display audit messages from the node SPARKS:

```
$ ACMSMGR SHOW LOG/NODE=SPARKS
```

You can display audit messages from a node other than the current node only if the Remote Manager is running on the target node. If the Remote Manager is not running on the target node, you must first log in to the target node, and then issue the SHOW LOG command using the /LOCAL qualifier.

The following example shows how to display audit messages on the current node when the Remote Manager process is not running:

```
$ ACMSMGR SHOW LOG/LOCAL
```

For a complete description of the ACMSMGR commands and qualifiers, see Chapter 11.

## 4.7.3. Resetting the Audit Log

Use the ACMSMGR RESET LOG command to close the current audit log file and open a new version. You may want to reset the log if it has grown too large.

The following example shows how to reset the log on node SPARKS:

```
$ ACMSMGR RESET LOG/NODE=SPARKS
```



# Chapter 5. Using the Remote Manager to Manage ACMS

## 5.1. Managing Data Collection

Data collection is the mechanism by which ACMS run-time data is made available to the ACMS Remote Manager and, consequently, to other processes. Data collections do not involve disk or network read or write operations. All data collection is performed in memory on the local node.

ACMS systems managers control what data is collected by manipulating entries in the Collection table. In the Collection table, the data to be collected is specified by a combination of entity, class, and name.

- *Entity* refers to an ACMS run-time process type, such as ACC, EXC, or CP.
- *Class* refers to the class of data to be collected (see Section 5.1.1).
- *Name* refers to a process or application name that uniquely identifies a particular ACMS run-time process.

Using the combination of entity, class, and name gives ACMS system managers a great deal of flexibility in configuring the data to be collected.

Data collection can be managed either statically, through the ACMSCFG file, or dynamically, using one of the supported interfaces. For example, the ACMSMGR SET COLLECTION command can be used to dynamically enable or disable data collection on a local or remote node. Similarly, SNMP management tools can issue SNMP SET commands to dynamically modify entries in the Collection table. Users can also write their own programs and use the remote procedure call ACMSMGMT\_SET\_COLLECTION\_1 (see Chapter 8) to dynamically manage data collection.

In general, management information is not collected unless an ACMS system manager has specifically enabled it. The exceptions are identification and configuration information. By default, these two classes of data are enabled for all ACMS entities. Having these classes enabled by default is an optimization that imposes little run-time overhead and ensures that process startup information is available. VSI recommends that you leave these classes enabled.

Data collection for other entities and classes is not enabled by default. When the ACMS system is started, the ACMS processes read either the configuration file (if the Remote Manager is not already running) or the Collection table to determine which classes of data to collect. Thereafter, external processes use the SNMP or RPC management interfaces to enable or disable data collection for a given entity, class, and name.

For each entity and class for which collection is enabled, a table of data values is populated by the appropriate ACMS processes (determined by name) and can be accessed by external entities using one of the data access interfaces (SNMP or RPC).

ACMS entities that collect data do so continuously when collection has been enabled for that entity/class/name combination. With the exception of event notifications (generated as the result of ACMS process startup or shutdown), and POOL information (which is updated based on timer intervals), collection data is modified when it changes.

## 5.1.1. Entities, Classes, Names, and Collections

ACMS system managers control data collection by modifying entries in the Collection table. The Collection table is keyed to entity, class, and name.

An *entity* is an ACMS run-time process or object. The valid ACMS entities are:

- ACC
- CP
- EXC
- QTI
- SERVER
- TASK GROUP
- TSC
- \* or ALL
- \* (all)

The wildcard value '\*' is valid, and specifies all entities. When specifying an entity, you are specifying the type of process that it is. The asterisk (\*) wildcard value is valid and specifies all entities. When specifying an entity, you are specifying its process type. The asterisk (\*) wildcard value is valid and specifies all entities. When specifying an entity, you are specifying its process type.

A *class* is a set of run-time data values that entities set. Referring to data by class is a convenient method of referring to a set of related data values. However, the actual values contained in a class are entity specific. The following are valid classes:

- Configuration

This class is a set of values that can be changed for the process and that controls some fundamental aspects of the execution. Configuration values are entity specific. An example of a Configuration class value for ACC is the maximum number of applications that may be running. An example value for a Server is the maximum number of instances.

- Identification

This class is a set of values that do not change for the process as long as it is running and that help identify the process. Examples of Identification class values are process name, PID, and version.

- Pool

This class is a set of values related to the current or historical MSS or workspace pool processing for the process. MSS pool values are the same for all entities except ACC. An example of a Pool class value for ACC is the current free amount in the MSS shared pool. An example value for other processes is the current free amount in the MSS process pool.

- Run-time

This class is a set of values that reflect either current or historical run-time processing for the process. Run-time values are also entity specific. An example of a Runtime class value for ACC is current number of applications. An example value for an EXC is the current number of executing tasks.

- \*

The asterisk is a wildcard value that specifies all classes.

A *name* specifies one or more specific processes of an entity type. The name field is entity specific. An example name for EXCs is the application name. An example name for CPs is process name. The wildcard value '\*' is also supported, and for CPs is process name. The asterisk (\*) wildcard value is also supported and matches all names.

Entity, class, and name are used in combination to determine which processes will collect which values. Duplicate rows (that is, rows with the same entity, class, and name) are not allowed, but it is possible to have overlapping entries in the Collection table if the wildcard value '\*' is used. Consider the example in table if the asterisk wildcard value is used. Consider the example in Table 5.1.

**Table 5.1. Example 1: Collection with Wildcards**

Name	Entity	Class
*	ACC	*
*	ACC	Runtime

In this example, the entries overlap but are not duplicates. This is allowed because the attributes of each collection may be different. But users should be cautious when using the wildcard to avoid redundant processing.

When more than one row applies, the most specific row will be used, based on the column precedence of name, then entity, and then class. Within a particular column, wildcards are the least specific. In Table 5.1, both rows are equivalent in name and entity, but the second row is more specific in class. In this case, the values from the first row will be used for all classes except the Runtime class. The values from the second row will be used for the Runtime class.

Consider the example in Table 5.2.

**Table 5.2. Example 2: Collection with Wildcards**

Name	Entity	Class	Collection State
*	*	Runtime	Enabled
*	EXC	Runtime	Disabled
VR_APPL	EXC	Runtime	Enabled

In this example, the first row enables run-time data collection for all entities. The second row disables it for all EXCs. The third row enables it for the VR\_APPL. As a result, among applications, only the VR\_APPL will collect run-time data.

As an aide to identifying which row is the most specific and therefore will apply to a given process, the ACMSMGR command SHOW COLLECTIONS includes a column that represents the weight of a given row. A row with higher weight overrides a row with lower weight when they apply to the same

class and process. Consider the following example, which is the same as the example in Table 5.2 but includes the weights (in the column labelled "Wt") of each row.

```
SPARKS> ACMSMGR SHOW COLLECTION
ACMS Remote Management -- Command line utility

ACMS V4.4-0 Entity/Collection Table Display Time: 19-APR-2001
11:46:36.49

Node          Wt Entity          Collect Collect
Storage      Storage
                Type   Entity Name   Class   State   Storage Location
State        Interval
-----
SPARKS        2  *           *           runtime enabled acms$mgmt_snapshot
enabled      3600
SPARKS        4  exc         *           runtime disabled acms$mgmt_snapshot
disabled    10
SPARKS        8  exc         VR_APPL     runtime enabled acms$mgmt_snapshot
disabled    10
```

In this example, the last row has the highest weight, and will override the other two rows for the RUNTIME class for the VR\_APPL.

## 5.1.2. Starting and Stopping Collections

Users start and stop data collections by modifying the *data collection state* field in the Collection table. The Collection table is accessed through either the ACMSCFG utility prior to management startup, or through the ACMSMGR utility after Remote Manager startup.

By default, the ACMSCFG file includes entries to enable collection for the Identification and Configuration classes for all processes. Unless specific action has been taken to disable these collections, identification and configuration information is always available for all running processes.

Before a collection can be modified, it must be added to the entity collection table. By default, if the collection state is not specified when a collection is added, the collection state is DISABLED. Otherwise, the collection state is whatever was specified.

When the data collection state is set to ENABLED, the Remote Manager sends messages to the appropriate ACMS processes (based on the entity and name fields in the Collection table row) to begin collection for the class. When the data collection state is set to DISABLED, a similar message is sent to stop collection for the class. Once collection has started, it continues until the data collection state is set to DISABLED.

The requesting user must have ACMSS\$MGMT\_WRITE privilege in order to start or stop a collection.

### 5.1.2.1. Using ACMSCFG to Start or Stop Collections

Use the ACMSCFG utility to set the state for a collection when the Remote Manager starts up. Some ACMSCFG commands are described here; for details on all ACMSCFG commands, see Chapter 10.

Use the ACMSCFG ADD COLLECTION command to create a new collection record. The command has the following syntax:

```
ACMSCFG ADD COLLECTION /ENTITY=entity /CLASS=class /NAME=name /
COLL_STATE=state
```

Use the ACMSCFG SET COLLECTION command to modify the state of an existing collection record in the configuration file. The command has the following syntax:

```
ACMSCFG SET COLLECTION /ENTITY=entity /CLASS=class /NAME=name /  
COLL_STATE=state
```

Use the ACMSCFG DELETE COLLECTION command to delete a collection. The command has the following syntax:

```
ACMSCFG DELETE COLLECTION /ENTITY=entity /CLASS=class /NAME=name
```

Deleting a collection can cause the Remote Manager to disable the class for a process because collections are disabled by default. The collection state for a process becomes disabled when no collections remain to specifically enable the class.

Use the ACMSCFG SHOW COLLECTION command to determine which collections already exist and their collection states. The command has the following syntax:

```
ACMSCFG SHOW COLLECTION
```

---

## Note

You cannot use the ACMSCFG utility to add, delete, or modify Collection and Identification class records.

---

### 5.1.2.2. Using ACMSMGR to Start or Stop Collections

Use the ACMSMGR utility to dynamically modify the state of a collection after the Remote Manager has already been started. Note that changes made with the ACMSMGR interface are not automatically stored in the ACMSCFG file and are lost when the Remote Manager is stopped.

Use the ACMSMGR ADD COLLECTION command to create a new collection record. The command has the following syntax:

```
ACMSMGR ADD COLLECTION /ENTITY=entity /CLASS=class /NAME=name /  
COLL_STATE=state
```

Use the ACMSMGR SET COLLECTION command to modify the state of an existing collection. The command has the following syntax:

```
ACMSMGR SET COLLECTION /ENTITY=entity /CLASS=class /NAME=name /  
COLL_STATE=state
```

Use the ACMSMGR DELETE COLLECTION command to delete a collection. The command has the following syntax:

```
ACMSMGR DELETE COLLECTION /ENTITY=entity /CLASS=class /NAME=name
```

Deleting a collection can cause the Remote Manager to disable the class for a process because collections are disabled by default. The collection state for a process becomes disabled when no collections remain to specifically enable the class.

Use the ACMSMGR SHOW COLLECTION command to determine which collections already exist and their collection states. The command has the following syntax:

```
ACMSMGR SHOW COLLECTION
```

### 5.1.2.3. Using SNMP to Start or Stop Collections

Use the SNMP interface to dynamically modify the state of a collection after the Remote Manager has already been started. Note that changes made with the SNMP interface are not stored in the ACMSCFG file and are lost when the remote Remote Manager is stopped.

The SNMP interface responds to SNMP commands issued by SNMP consoles. An SNMP console issues an SNMP SET command to the Remote Manager to modify the Collection table.

The SNMP OID (object ID) for the collection state columns are listed in the file MIB\_OID.LIS in ACMS\$RM\_EXAMPLES. The data type for the field is INTEGER. Possible settings for this field have the following meanings:

- 0 = Collection is disabled.
- 1 = Collection is enabled.
- 9 = Collection record is deleted.

You cannot add a collection record using the SNMP interface.

## 5.2. Displaying Collected Data

Management data can be displayed using either the ACMSMGR utility or one of the programming interfaces (SNMP or ONC RPC). Data is displayed by entity and, optionally, by class.

### 5.2.1. Using ACMSMGR to Display Collected Data

Use the ACMSMGR SHOW command to display collected data. See Chapter 11 for a description of each command.

The following ACMSMGR command displays ACC data:

```
$ ACMSMGR SHOW ACC /NODE=SPARKS /ID
```

The following example shows output from this command:

```
ACMS Remote Management Option -- Command line utility
ACMS V4.4-0   ACC Table Display                       Time: 19-APR-2001
11:59:09.56
```

Node	ID				
User Name	Class	PID	Process Name	Start Time	
	Version				
sparks	enabled	2020C8BB	ACMS01ACC001000	18-APR-2001	14:44:47.29
SYSTEM	V4.4-0				

## 5.3. Managing ACMS Using the Remote Manager

The ACMS Remote Manager provides the ability to modify the running ACMS system using either the SNMP or the RPC interface. In general, only Configuration class variables can be modified at run

time. However, not all Configuration class variables can be modified. Chapter 9 lists all Configuration class variables by entity and indicates which ones can be modified.

## 5.3.1. Types of Variables

Many Configuration class variables can have the following two forms:

- Stored variable (see Section 5.3.1.1)
- Active variable (see Section 5.3.1.2)

The programming interfaces expose stored and active values as separate variables.

### 5.3.1.1. Stored Variables

Stored variables are maintained by the ACMS run-time system on disk, either in the ACMSGEN file or as part of an ADB or TDB file. For example, `mss_maxobj` is a run-time variable that is stored in the ACMSGEN file. The auditing state for a particular application is a run-time variable that is stored in the application database (ADB).

As you might expect, the ACMS Remote Manager allows ACMSGEN stored values to be modified, but it does not allow modifications to values that are stored in application executables.

Changes to stored values are durable but not dynamic. That is, if the stored value of a variable is modified, the value survives the restart of the ACMS run-time system. However, changes to stored values do not take effect immediately. Some or all of the ACMS run-time system needs to be restarted before the new value takes effect.

For example, to change the value of the `mss_net_retry_timer` parameter in the ACMSGEN file using ACMSMGR, use the following command:

```
$ ACMSMGR SET ACC/MSS_NET_RETRY_TIMER=50/STORED
```

To change the value in ACMSGEN file using the RPC interface, set the `mss_net_retry_timer_stored` field in the `acc_config_rec` using the `ACMSMGMT_SET_ACC` procedure. To change the same value using an SNMP console, set the `acc_mss_net_retry_timer_stored` field in the ACC Table.

Note that none of these changes would effect the running system. To effect the running system, you must change the active value (see Section 5.3.1.2.)

### 5.3.1.2. Active Variables

Active variables are maintained in memory by the ACMS run-time system. All Configuration class variables are active because they have an in-memory value. Although the ACMS Remote Manager allows most active values to be modified, not all changes to active values are dynamic. Refer to Chapter 9 to determine whether a particular active value is dynamic. Changes to nondynamic active variables are essentially useless.

Changes to active values are never durable; that is, they never survive a restart of the system.

For example, to change the active value of the `mss_net_retry_timer` using ACMSMGR, use the following command:

```
$ ACMSMGR SET ACC/MSS_NET_RETRY_TIMER=50/ACTIVE
```

To change the value using the RPC interface, set the `mss_net_retry_timer_active` field in the `acc_config_rec` using the `ACMSMGMT_SET_ACC` procedure. To change the same value using an SNMP console, set the `acc_mss_net_retry_timer_active` field in the ACC table.

Note that none of these changes would survive a system restart. To change a value and have it survive a system restart, you have to change the stored value (see Section 5.3.1.1.)

## 5.3.2. How the Remote Manager Makes Changes

The ACMS Remote Manager applies changes to the ACMS run-time system either by using the `ACMSGEN` parameter file and utility, or through the `ACMSOPER` utility. In either case, the ACMS Remote Manager server applies updates to the running system by creating temporary command procedures that are executed by a spawned DCL subprocess (process name `ACMS$MGMT_DCL`).

The temporary command procedures are written to and read from the directory pointed to by the logical name `ACMS$MGMT_TEMP`. If this logical is not defined when the Remote Manager starts, it will define the logical to point to `SY$MANAGER`.

Temporary command procedures are given names unique to the procedure instance that creates them, but the names are not unique across nodes. These names are deleted after they have been executed.

If the Remote Manager server does not have access to the directory pointed to by `ACMS$MGMT_TEMP`, all update attempts fail. However, the definition of the logical can be changed without restarting the Remote Manager. Changing the definition at run time should be done cautiously. One or more updates could fail if the logical is changed in the middle of an update operation.

If the `ACMSMGR` or RPC interface is used, any errors that occur during the system update are returned to the user and are written to the Remote Manager log file. Depending on the current setting of the `dcl_audit_level` parameter, some messages may not be written to the log.

User accounts (including proxy accounts and the `ACMS$SNMP` account, if SNMP is being used) must be granted the `ACMS$MGMT_WRITE` or `ACMS$MGMT_OPERATE` rights identifier in order to modify Configuration class values. See Section 4.4.2 for a list of functions and the rights identifier required for each.

## 5.3.3. Using ACMSMGR to Modify the ACMS Run-Time System

The `ACMSMGR` utility can be used to dynamically modify Configuration class parameters for ACMS run-time entities. More than one value can be modified at once, on one or more nodes. The command executes synchronously; that is, it does not complete until an attempt has been made to update all parameters. Multiple node updates are processed serially; all updates are performed on one node before any updates are attempted on subsequent nodes.

Use the `ACMSMGR SET` command to modify a Configuration class variable. The syntax of the command is as follows:

```
ACMSMGR SET entity [/parameter=value,...]
```

For example, the following command disables ACMS auditing on the node specified by ACC:

```
$ ACMSMGR SET ACC /AUDIT_STATE=DISABLED
```



Two qualifiers are provided to control whether the active (/ACTIVE) or stored (/STORED) value of the variable is to be modified. The default is /STORED. Both qualifiers can be specified in a single command to update both values. For example, the following command modifies both the active and stored values of the ACC Configuration class variable *node\_name*:

```
$ ACMSMGR SET ACC/NODE_NAME=SPARKS/ACTIVE/STORED
```

If a specified qualifier does not apply (for example, /ACTIVE is specified for a nondynamic variable), the qualifier is ignored.

For a complete list of Configuration class variables, see Chapter 9.

The ACMSMGR START and STOP commands can be used to dynamically start and stop the following processes:

- ACC (starts or stops the entire ACMS run-time system)
- EXC
- MANAGER (Remote Manager; stop only)
- QTI
- TRACE\_MONITOR
- TSC (starts or stops the TSC and any CPs)

In addition, ACMS procedure servers can be replaced (stopped and restarted) using the ACMSMGR REPLACE command.

Different qualifiers are available for each command and process.

For more information about ACMSMGR commands, refer to Chapter 11.

### **5.3.4. Using SNMP to Modify the ACMS Run-Time System**

The SNMP interface can be used to dynamically modify Configuration class parameters for ACMS run-time entities. Updates to Configuration class parameters are synchronous; the SNMP command does not complete until an attempt has been made to update the parameter.

The SNMP interface responds to SNMP commands issued by SNMP consoles. An SNMP console issues an SNMP SET command to the Remote Manager to modify Configuration class parameters.

There are both active and stored values for many of the Configuration class variables. In the ACMS MIB, each value is given a separate variable (OID).

Because the SNMP protocol offers only GET and SET commands, the SNMP interface handles the following operations differently from the RPC interface in order to perform the full range of management activities:

- Starting and stopping processes (see Section 5.3.4.1)
- Adding and deleting table rows ( Section 5.3.4.2)

- Replacing servers ( Section 5.3.4.3)

Not all operations that can be performed by the RPC interface can be performed by the SNMP interface. The following sections indicate which operations are not available in the SNMP interface.

### 5.3.4.1. Starting and Stopping Processes Using SNMP

To start or stop the following ACMS processes, issue an SNMP SET command on the Configuration class variable *acms\_state*, and specify the state as either 1 (to start the process) or 0 (to stop the process).

- ACC
- QTI
- TSC

You cannot start or stop CP processes.

To start an ACMS application, issue an SNMP SET command on the *exc-appl-name* field in the *excTable*, specifying a row that is not currently in use and that is less than the value of the *acc-max-appl-active* field in the *accTable*.

To stop an ACMS application, issue an SNMP SET command on the *exc-acms-state* field, specifying a value of 0.

You cannot start or stop application procedure servers or task groups.

### 5.3.4.2. Adding and Deleting Rows Using SNMP

Currently, no tables allow rows to be added using SNMP.

The Collection and Trap tables allow rows to be deleted using SNMP.

- To delete rows from the Collection table, set the *collection-state* field to 9. (A value of 1 enables the collection; a value of 0 disables the collection; a value of 9 deletes the collection.)
- To delete rows from the Trap table, set the *trap-delete* field to 1. This is the only value allowed for this field.

### 5.3.4.3. Replacing Application Procedure Servers Using SNMP

To replace an ACMS application procedure server, issue an SNMP SET command on the *ser-replace-flag* field in the Server table, specifying a nonzero value.

## 5.3.5. Using ONC RPC to Modify the ACMS Run-Time System

The RPC interface can be used to dynamically modify Configuration class parameters for ACMS run-time entities. Configuration class parameter updates are synchronous; the RPC command does not complete until an attempt has been made to update the parameter.

There are both active and stored values for many of the Configuration class variables. In the *ACMSMGMT\_RPC.X* IDL file, each value is given a separate variable.

Separate RPC commands for each entity type are provided for modifying Configuration class variables. In addition, RPC commands are provided to perform start, stop, add, delete, replace, and reset functions. Chapter 8 provides details about all of the RPC commands.



# Chapter 6. Management Programming Using ONC RPC

Programmers who want to access and maintain the ACMS Remote Manager from their own programs can use the following two interfaces:

- Simple Network Management Protocol (SNMP)

The SNMP interface is provided for integration with enterprise management packages such as PATROL ® from BMC ® and Tivoli from IBM ®. For more information, see Chapter 7.

- Open Network Computing (ONC) Remote Procedure Call (RPC)

The ONC RPC interface is for system managers and system programmers who want to write custom tools and applications that access the ACMS Remote Manager.

This chapter describes the ONC RPC interface. Programmers who are familiar with the C programming language and RPC mechanisms can use this information when coding and building their own client programs. For a more complete discussion of ONC RPC programming, see *Power Programming with RPC* by John Bloomer, published by O'Reilly & Associates, Inc., Sebastopol, CA.

## 6.1. ONC RPC Overview

ONC RPC is a widely used and supported remote procedure call (RPC) mechanism. Similar to other RPC mechanisms, the ONC RPC protocol supports a request/response model, in which client applications make requests of servers and receive responses. Clients typically make synchronous calls to remote servers over a network. The RPC mechanism hides the network operations from the programmer, making each remote procedure call appear to be a local function invocation.

Unlike the SNMP interface, which connects to the ACMS Remote Manager using the SNMP master agent, access through ONC RPC is directly to the ACMS Remote Manager.

Figure 6.1 provides a graphical overview of the ONC RPC interface.

**Figure 6.1. ONC RPC Interface Overview**

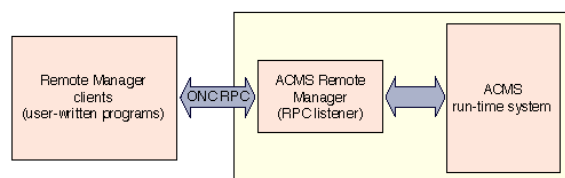

Programming for ONC RPC is based on interface definitions coded in Interface Definition Language (IDL). Functions and their arguments are described in IDL source files, which are precompiled using an IDL compiler. The outputs from the IDL compiler are a set of C source and header files that are then compiled and linked with client and server programs to form run-time executables. (For Remote Manager client development, server stub files are not needed and can be discarded.)

Figure 6.2 provides a graphical overview of programming for ONC RPC.

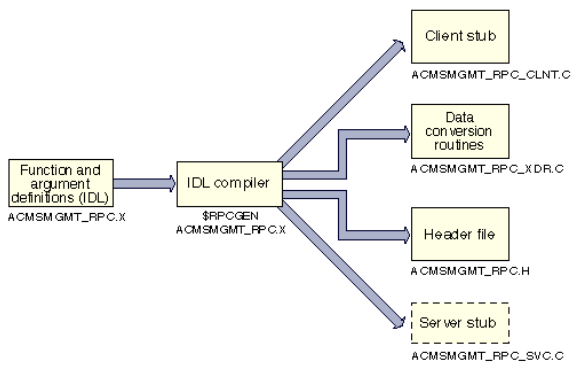
**Figure 6.2. ONC RPC Programming Overview**

The IDL that describes the procedures supported by the ACMS Remote Manager is provided with the ACMS Remote Manager installation and provides the basis for ACMS management programming. Users write their own client programs, calling the functions described in the ACMS Remote Manager IDL file (ACMSMGMT\_RPC.X). They precompile the IDL file with the precompiler provided by their TCP/IP package, and then compile and link their client programs. No compilation or linking is required for the Remote Manager; it contains all the support required by ONC RPC client programs.

The ACMS Remote Manager provides several types of procedures that are callable through the ONC RPC interface. These procedures provide read and write access to each table maintained by the Remote Manager, as well as command routines (such as start and stop). Table 6.1 summarizes the types of procedures available.

**Table 6.1. Procedures for Accessing Remote Manager Functions**

Procedure Type	Table or Object	Description
Add	Collection, Trap	Allows entries to be added to configuration tables.
Delete	Collection, Trap	Allows entries to be removed from configuration tables.
Get	ACC, MGR_STATUS, PARAM, QTI, TSC	Returns all columns in the table.
List	Collection, CP, EXC, Interfaces, Log, Process, Trap, Server, Task Group, Users	Returns a linked list of records based on selection criteria. All columns in the table are returned with each row.
Replace	Server	Allows an application server to be replaced.
Reset	Log	Allows the current version of the Remote Manager log to be closed and a new version to be opened.
Set	ACC, CP, Collection, EXC, Interfaces, Trap, Param, QTI, SERVER, TSC	Allows modifications to the table. For configuration tables, set functions allow rows to be added to tables. (Entity rows can only be added by starting the appropriate process.)

Procedure Type	Table or Object	Description
Start	ACC, TSC, QTI, EXC, Trace Monitor	Allows ACMS processes to be started.
Stop	Manager, ACC, TSC, QTI, EXC, Trace Monitor	Allows ACMS processes to be stopped.

The procedure names and arguments for each procedure type are similar — all get calls have similar names and arguments; set calls have similar names and arguments, and so on.

The sections that follow describe in more detail how to write programs that access these functions.

## 6.2. API Overview

Remote management client programs follow a typical programming model that involves the following phases:

- Initialization

During the *initialization* phase, client programs establish connections with the Remote Managers they will be calling. As part of this phase, the programs select a security mode (explicit or implicit). Once this phase is complete, the Remote Managers have been verified to be available, and the client authentication has been verified. This phase involves using a combination of ONC RPC function calls and an ACMS Remote Manager function call (if explicit authentication is being used).

- Processing

During the *processing* phase, client programs make procedure calls to the Remote Managers. During this phase, clients obtain or modify management information. This phase involves the use of the functions defined in the `ACMS$RM_EXAMPLES:ACMSMGMT_RPC.X` IDL file.

- Termination

During the *termination* phase, clients halt execution. There is no API support or programming requirement for this phase.

## 6.3. Initialization and Security

In order to perform initialization, ACMS remote client programs must first determine the type of authentication (explicit or implicit) they will use. The type of authentication determines whether or not the client program must obtain credentials.

The Remote Manager performs authentication either *explicitly*, using a valid OpenVMS account name and password, or *implicitly*, using ACMS proxies. Implicit authentication is allowed only if it has been enabled on the Remote Manager node, and does not require the use of credentials. Explicit authentication requires the use of credentials and also requires that the client process execute a separate login using the `ACMSMGR` utility.

See Section 4.4 for a discussion of the various security modes and how to log in using `ACMSMGR`.

Once the authentication mode has been determined, remote management clients perform the following tasks:

- Establish an RPC connection with the Remote Manager on the target node.

The `clnt_create` function call establishes RPC client connections.

- Establish the security context and, optionally, populate it with credentials information.

The security context is established by calling the `authunix_create_default` function. As a result of this call, client process-identity information is passed to the server on each procedure call. The Remote Manager uses this information to authorize the user for each function.

The default security context is not sufficient if explicit authentication is being used. Clients that need to support explicit authentication call the `acms$mgmt_get_credentials` function to obtain a client ID, which was previously issued for the client process by executing a login through the ACMSMGR utility. This client ID is used on subsequent RPC calls.

---

## Note

In order for credentials information to be created, the client process must first execute the login command of the ACMSMGR utility. The only way to create credentials files is by using the ACMSMGR utility.

---

### 6.3.1. Initialization Example

The following example code shows a client program that establishes an RPC connection with the Remote Manager, establishes the security context, and then populates it with credentials information if a logical name (ACMS\$MGMT\_USER) has been defined.

```
#include <rpc/rpc.h>
#include string
#include "acmsmgmt_rpc.h"

CLIENT *cl;
char sname[] = "sparks";
char *username_p, username[13] = "";
int client_id;
int status;

int acms$mgmt_get_creds();

int main ()
{
    /* if the logical is defined, credential information will be used */
    username_p = getenv("ACMS$MGMT_USER");
    if (username_p)
        strcpy(username, username_p);

    /* establish an rpc connection to the server */
    cl = clnt_create(sname, ACMSMGMT_RPC, ACMSMGMT_VERSION, "tcp");

    /* if the connection was established */
    if (cl != NULL) {

        /* create a security context */
        cl->cl_auth = authunix_create_default();
```



```

    client_id = 0;

    /* optionally, get credentials for this user & server */
    if (strlen(username))
        status = acms$mgmt_get_creds(sname,username,&client_id);

    }

return(1);
}

```

## 6.4. Get Procedures

Get procedures are available for all ACMS Remote Manager tables. Get procedures return all columns from a single table row.

As Table 6.2 shows, a separate get procedure is available for each entity and table.

Input arguments to get procedures are **client\_id**. See Chapter 8 for details about each call.

**Table 6.2. Get Procedures**

Procedure	Description
acmsmgmt_get_acc_1	No keys; only 1 ACC per node.
acmsmgmt_get_mgr_status_1	No keys; only one row in the Manager Status table.
acmsmgmt_get_param_1	No keys; only one row in the Parameter table.
acmsmgmt_get_qti_1	No keys; only 1 QTI per node.
acmsmgmt_get_tsc_1	No keys; only 1 TSC per node.

### 6.4.1. Get Example

The following example code shows how a client program calls the `acmsmgmt_get_param_1` procedure and displays the current value of a parameter.

```

int get_param_data(int client_id,CLIENT *cl)
{
    int x = 0;
    int y = 0;

    param_rec2      *params;
    param_rec_out2  *param_rec;
    static struct sub_id_struct sub_rec;
    int status;

    sub_rec.client_id = client_id;

    param_rec = acmsmgmt_get_param_2(&sub_rec,cl);

    if (!param_rec) {
        printf("\n RPC Call to get Parameter data failed");
        return(MGMT_FAIL);
    }
}

```

```

if (param_rec->status != MGMT_SUCCESS) {
    printf("\n Call to get Parameter data failed, returning status code
%d",
        param_rec->status);
    status = param_rec->status;
    xdr_free(xdr_param_rec_out2, param_rec);
    free(param_rec);
    return(status);
}

params = &param_rec->param_rec_out2_u.data;

printf("\n Maximum logins allowed is %d",params->max_logins);
xdr_free(xdr_param_rec_out2, param_rec);
free(param_rec);
return(0);
}

```

## 6.5. List Procedures

List procedures operate on all rows in a table. Procedures are available for each entity and each configuration table with more than one row. There are no list procedures for the following tables, since they contain only one row:

- ACC table
- TSC table
- QTI table
- Parameter table

As Table 6.3 shows, separate list procedures are provided for the remainder of the management information and configuration tables. Input to a list procedure is a selection criteria record, which varies depending on the table being accessed. Some key values in the selection criteria records will support wildcards (\*, %). support wildcards (\*, %).

**Table 6.3. List Procedures**

Procedure	Description
acmsmgmt_list_collections_1	Key value is table index.
acmsmgmt_list_cp_1	No keys.
acmsmgmt_list_exc_1	Key value is application name or table index.
acmsmgmt_list_interfaces_1	No keys.
acmsmgmt_list_log_1	No keys; selection criteria is before_time, since_time, file_name, facility, severity.
acmsmgmt_list_proc_1	No keys.
acmsmgmt_list_server_1	Key value is application name, server name, or table index.
acmsmgmt_list_tg_1	Key value is application name, task group name, or table index.

Procedure	Description
acmsmgmt_list_trap_1	No keys.
acmsmgmt_list_users_1	No keys.

For all list procedures, only entire rows (that is, all columns in the row) are returned. Data is returned in a linked list. The number of nodes in the list is determined by the systemwide parameter table field `max_rpc_return_recs`. When the number of rows to be returned exceeds the value of `max_rpc_return_recs`, the caller must reissue the call, providing the appropriate key values to fetch the next set of rows. The call returns status `MGMT_NO_MORE_ROWS` if there are no more rows available. Procedures with no keys return all rows in the table on the first call, regardless of the value of the `max_rpc_return_recs` field.

## 6.5.1. Linked List Example

Data from list calls is returned in a linked list. The example in this section uses the `acmsmgmt_list_log_1` procedure to illustrate how linked list processing works.

The call to the `acmsmgmt_list_log_1` procedure requires the following input structure:

```
struct log_sel_struct {
    int         client_id;
    string      before_time<TIME_SIZE_A>;
    string      since_time<TIME_SIZE_A>;
    string      file_name<STORAGE_LOC_SIZE>;
    int         dup_count;
    int         facility;
    int         severity;
};
```

In the code example that follows, the lines of code beginning with `log_rec` initialize the fields in this structure as follows:

- `Client_id` is set to 0 to select proxy authentication.
- `Before_time` is set to a NULL string to specify no end date for viewing log entries. Note that you cannot provide a NULL pointer.
- `Since_time` is set to the 1st of January 1998. Log entries from this date and later will be viewed.
- `File_name` is set to an empty string, which causes the active log file to be used.
- `Dup_count` is set to -1. This field is used to uniquely identify log records with identical times.
- `Facility` is set to -1, which causes entries for all facilities to be returned.
- `Severity` is set to -1, which causes entries of all severity levels to be returned.

The following example code shows the initialization of the client and the call to the `acmsmgmt_list_log_1` procedure:

```
static struct log_sel_struct log_rec; log_data_list *log; log_link
    *nl; char null_time_str[24] = ""; char first_of_jan[24] = "01-
JAN-1998 00:00:00.00"; char file_spec[] = "ACMS$MGMT_LOG"; char sname[]
    = "sparks"; int skip_rec = 0; /* Initialize client connection; if that
```

```

fails, exit*/ cl = clnt_create(sname, ACMS_MGMT_RPC, ACMS_MGMT_VERSION,
"tcp"); if (!cl) return(FAIL); /* Create a default security context */
cl->cl_auth = authunix_create_default(); /* So far so good. Initialize
log selection data */ log_rec.client_id = 0; log_rec.before_time =
null_time_str; log_rec.since_time = first_of_jan; log_rec.file_name =
file_spec; #include
<rpc/rpc.h> #include
<stdio.h> #include string #include "acmsmgmt_rpc.h" CLIENT *cl;
int main () { int skip_rec = 0; char null_time_str[24] = ""; char
first_of_jan[24] = "01-JAN-1998 00:00:00.00"; char file_spec[] =
""; /* use default, i.e. active log file */ char sname[] = "sparks";
char time_cache[MGMT_S_TIME_A+1]; top; /* Now make RPC */ log =
acmsmgmt_list_log(log_rec,cl);

static struct log_sel_struct log_rec; log_data_list *log; log_link *nl; /* Initialize client connection;
if that fails, exit*/ cl = clnt_create(sname, ACMSMGMT_RPC, ACMSMGMT_VERSION,
"tcp"); if (!cl) return(MGMT_FAIL); /* Create a default security context */ cl->cl_auth =
authunix_create_default(); /* So far so good. Initialize log selection data */ log_rec.client_id = 0;
log_rec.before_time = null_time_str; log_rec.since_time = first_of_jan; log_rec.file_name = file_spec;
log_rec.dup_count = -1; log_rec.facility = -1; /* don't match on facility */ log_rec.severity = -1; /*
don't match on severity */ top; /* Now make RPC */ log = acmsmgmt_list_log_1(&log_rec,cl);

```

The return value from the calls to all list procedures (including `acmsmgmt_list_log_1`) is a pointer to a union. If the pointer returned is `NULL`, the call has failed. RPC error checking must be used to determine the cause of the error. If a valid pointer has been returned, it will point to a structure containing a union with the following structure:

```

#include <rpc/rpc.h>
#include <stdio.h>
#include string
#include "acmsmgmt_rpc.h"

CLIENT *cl;

int main ()
{

int skip_rec = 0;

char null_time_str[24] = "";
char first_of_jan[24] = "01-JAN-1998 00:00:00.00";
char file_spec[] = ""; /* use default, i.e. active log file */
char time_cache[MGMT_S_TIME_A+1];
static struct log_sel_struct log_rec;
log_data_list *log;
log_link *nl;

/* Initialize client connection; if that fails, exit*/

cl = clnt_create(sname, ACMSMGMT_RPC, ACMSMGMT_VERSION, "tcp");
if (!cl)
    return(MGMT_FAIL);

/* Create a default security context */

cl->cl_auth = authunix_create_default();

```

```

/* So far so good. Initialize log selection data */

log_rec.client_id    = 0;
log_rec.before_time = null_time_str;
log_rec.since_time  = first_of_jan;
log_rec.file_name   = file_spec;
log_rec.dup_count   = -1;
log_rec.facility    = -1; /* don't match on facility */
log_rec.severity    = -1; /* don't match on severity */

top:
/* Now make RPC */
log = acmsgmt_list_log_1(&log_rec,cl);

```

The status field determines which structure is being returned. If the status is equal to `MGMT_FAIL`, the `rc` field is returned. The `rc` field contains a status code indicating the reason for failure.

If the status field is not equal to `MGMT_FAIL`, a pointer to a linked list has been returned.

The `log_list` field is defined as a pointer to linked list node, as follows:

```
typedef struct log_link *log_list;
```

The linked list node has the following structure:

```

struct log_link {
    logging_rec log_data;
    log_list pNext;
};

```

In this structure, `log_data` is of type `logging_rec`, which is a record structure containing the log data. The `pNext` field is a pointer to the next node in the linked list (which is of type `log_link`).

Figure 6.3 illustrates the return structure and how the linked list is constructed.

**Figure 6.3. Linked List: Return Structure and Construction**

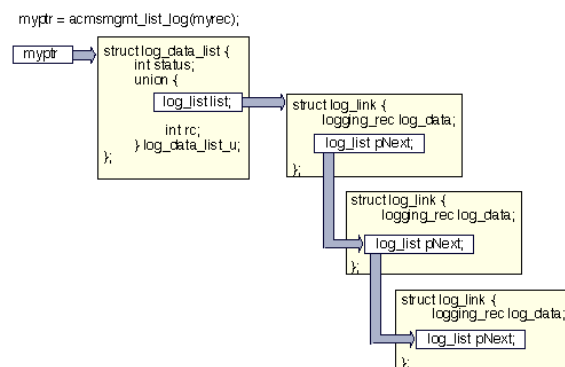

The following example code shows how to check whether the call completed successfully, and how to traverse the linked list to display the data:

```

/* if a NULL pointer was returned, the RPC failed */
if (!log)
    return(MGMT_FAIL);

/* if bad status was returned, something failed in our call.

```

```

        log->log_data_list_u.rc contains the status */
if (log->status == MGMT_FAIL)
    return(log->log_data_list_u.rc);

/* while more data in the list, display the data */
for (nl = log->log_data_list_u.list; nl != NULL; nl = nl->pNext) {
    if (skip_rec)
        skip_rec = 0;
    else
        printf("\n %-12s\t%-s",sname,nl->log_data.log_msg);

    /* save last time received to use as next time to read forward from
    */
    memcpy(&time_cache[0],nl->log_data.log_msg,23);
    log_rec.dup_count = nl->log_data.dup_count;
    log_rec.since_time = time_cache;
}
if (log->status == MGMT_NOMORE_DATA)
    printf("\n *** End of data ***");
else {
    skip_rec = 1;
    goto top;
}

return(1);
}

```

In this example, the returned pointer is checked for whether data has been returned (log is not NULL). Then the status code is checked for whether the call completed successfully.

If the call completed successfully, the code drops into a FOR loop and starts printing the data. For this particular call, the client prints all the records the very first time the RPC is called; on subsequent calls, the first record is a duplicate of the last one from the previous call and is not printed.

After printing a record, the key data is saved to be used again on a subsequent call. Remember that only `max_rpc_return_recs` is returned in each call to the `acmsmgmt_list_log_data_1` procedure. There may be more log records than can be sent at once. It is the responsibility of the client to initialize the call properly to get the next set of records.

Once all the returned records have been returned, the code will call the `acmsmgmt_list_log_data_1` procedure again if the status code from the call was not `MGMT_NOMORE_DATA`. In this way, all the records are retrieved.

## 6.6. Set Procedures

Set procedures are available for many of the ACMS Remote Manager tables. Set procedures allow you to modify ACMS entity and Remote Manager configuration information. As Table 6.4 shows, a separate set procedure is available for each entity and table.

**Table 6.4. Set Procedures**

Procedure	Description
<code>acmsmgmt_set_acc_1</code>	No keys; only 1 ACC per node.
<code>acmsmgmt_set_coll_1</code>	Key value is entity, ID, and class.

Procedure	Description
acmsmgmt_set_exc_1	Key value is application name.
acmsmgmt_set_interface_1	Key value is interface name.
acmsmgmt_set_param_1	No keys; only one row in the parameter table.
acmsmgmt_set_qti_1	No keys; only 1 QTI per node.
acmsmgmt_set_server_1	Key value is application name and server name.
acmsmgmt_set_trap_1	Key value is entity, ID, and parameter.
acmsmgmt_set_tsc_1	No keys; only 1 TSC per node.

For Entity tables, set procedures allow fields to be modified for a particular entry. A unique key value must be provided to identify the particular table row to be updated for tables with more than one row. Only configuration class fields can be modified in entity tables.

For the Trap and Collection tables, add and delete procedures (described in Section 6.7 and Section 6.8) are available along with set procedures. Each procedure requires a unique key value.

For all tables, some or all fields in a row can be modified in a single call. The Remote Manager scans the input record for uninitialized fields (that is, fields that are not set to the default value of -1); if a field contains an initialized value, the Remote Manager attempts to apply the update. The corresponding field in the return record is updated with the completion status of the update. Updates are applied serially, but the Remote Manager attempts to update all initialized fields regardless of the outcome of any individual update. The exception to this processing is if an internal error occurs, in which case processing is aborted.

All calls are synchronous.

See Chapter 8 for details about each call.

### 6.6.1. Set Example

The following example code shows how a client program calls the `acmsmgmt_set_param_1` procedure to change the values of the `proc_mon_interval` and `mss_coll_interval` parameters.

This example assumes client initialization has been performed as described in Section 6.3.

```
int set_param_data(int client_id, CLIENT *cl)
{
    int x = 0;
    int y = 0;

    static param_config_rec2 set_struct;
    param_status_rec2 *ret_struct;
    static int *status;

    /* initialize input argument; values < 0 are not processed
       by the server */
    memset(&set_struct, -1, sizeof(set_struct));

    /* establish the client id */
    set_struct.client_id = client_id;
    set_struct.params.proc_mon_interval = 60;
    set_struct.params.mss_coll_interval = 60;
}
```

```
ret_struct = acmsgmt_set_param_2(&set_struct,cl);

if (!ret_struct) {
    printf("\nCall to modify parameters failed");
    return(MGMT_FAIL);
}

if (ret_struct->status != MGMT_SUCCESS) {

    if (ret_struct->status != MGMT_WARN) {
        printf("\nCall to modify parameters failed, returning %d",
            ret_struct->status);
        status=ret_struct->status;
        xdr_free(xdr_param_status_rec2, ret_struct);
        free(ret_struct);
        return(MGMT_FAIL);
    }

    if (ret_struct->param_status_rec_u.data.proc_mon_interval !=
MGMT_SUCCESS)
        printf("\n Call to modify proc_mon_interval failed");
    if (ret_struct->param_status_rec_u.data.mss_coll_interval !=
MGMT_SUCCESS)
        printf("\n Call to modify mss_coll_interval failed");
        xdr_free(xdr_param_status_rec2, ret_struct);
        free(ret_struct);
    return(MGMT_FAIL);
}
else
    printf("\n Call to update parameters successful");
    xdr_free(xdr_param_status_rec2, ret_struct);
    free(ret_struct);
    return(0);
}
```

In this example, note that the input argument (**set\_struct**) is initialized to negative values prior to the call. The Remote Manager will attempt to apply updates for any positive values found; negative values are ignored.

Following the call to the update routine, the return record pointer is tested to ensure that it is not NULL (that is, that the call completed). Then individual return codes are tested to determine the status of the updates. The first status check (`ret_rec->status`) determines the overall call status. For instance, security violations will be recorded in this field. If that status field contains a failure code, no updates were attempted. If that status field contains `MGMT_SUCCESS`, updates were attempted for the two fields. The subsequent status checks in the return record determine the outcome of those updates.

## 6.7. Delete Procedures

Delete procedures are available for the Collection and Trap tables. Delete procedures allow you to remove rows from the corresponding table. As Table 6.5 shows, a separate delete procedure is available for each of these tables.

The delete procedures require an input record with key data to be passed by the caller. A simple status code is returned indicating the success or failure of the operation.

All calls are synchronous.



See Chapter 8 for details about each call.

**Table 6.5. Delete Procedures**

Procedure	Description
acmsmgmt_delete_collection_1	Key value is entity, ID, and class.
acmsmgmt_delete_trap_1	Key value is entity, ID, and parameter.

### 6.7.1. Delete Example

The following example code shows how a client program calls the `acmsmgmt_delete_collection_1` procedure to remove a collection row.

This example assumes that client initialization has been performed as described in Section 6.3.

```
int del_coll_data(int client_id, CLIENT *cl)
{
    static int *status;
    static coll_del_rec set_struct;
    static char ent_name[MGMT_S_ENTITY_NAME];

    set_struct.client_id = client_id;
    set_struct.entity_type      = MGMT_ACC;
    strcpy(ent_name, "*");
    set_struct.entity_name      = ent_name;
    set_struct.collection_class = MGMT_CLASS_ALL;

    status = acmsmgmt_delete_collection_1(&set_struct, cl);

    if (!status) {
        printf("\n Call to delete collection failed");
        return(MGMT_FAIL);
    }

    if (*status != MGMT_SUCCESS) {
        printf("\nCall to delete collection failed with status
%d", *status);
        return(MGMT_FAIL);
    }
    else
        printf("\nCall to delete collection was executed");
        free(status)
        return(0);
}
```

In this example, the input record is prepared with key information, and then the call to delete the row is performed. Following the call to the delete routine, the value pointed by `status` is checked for success or failure. In either event, a message is printed out indicating the completion status of the call.

## 6.8. Add Procedures

Add procedures are available for the Collection and Trap tables. Add procedures provide the ability to add rows to the corresponding table. As shown in Table 6.6, a separate add procedure is available for each of these tables.

The add procedures require an input record with an entire table row, including unique key data to be passed by the caller. The Remote Manager validates the input fields before adding the record, including checking for duplicate keys. A record is returned with an overall status code indicating the success or failure of the operation, and with individual status codes for each field indicating which fields are invalid.

All calls are synchronous.

See Chapter 8 for details about each call.

**Table 6.6. Add Procedures**

Procedure	Description
acmsmgmt_add_collection_1	Key value is entity, ID, and class.
acmsmgmt_add_trap_1	Key value is entity, ID, and parameter.

## 6.8.1. Add Example

The following example code shows how a client program calls the `acmsmgmt_add_collection_1` procedure to add a collection row.

This example assumes client initialization has been performed as described in Section 6.3.

```
int add_collection_data(int client_id, CLIENT *cl)
{
    static char c_name_all[2]      = "*";
    static coll_config_rec_2 set_struct;
    struct coll_status_rec_2 *status_rec;

    set_struct.client_id          = client_id;
    set_struct.coll.entity_type   = MGMT_ACC;
    set_struct.coll.entity_name   = c_name_all;
    set_struct.coll.collection_class = MGMT_CLASS_ALL;
    set_struct.coll.collection_state = MGMT_STATE_ENABLED;

    status_rec = acmsmgmt_add_collection_2(&set_struct, cl);

    if (!status_rec) {
        printf("\n Call to add collection record failed");
        return(MGMT_FAIL);
    }

    if (status_rec->status == MGMT_WARN) {
        printf("\nThe following fields are invalid: ");
        if (status_rec->coll_status_rec_2_u.data_warn.entity_type ==
MGMT_FAIL)
            printf("\n    entity_type");
        if (status_rec->coll_status_rec_2_u.data_warn.collection_class
== MGMT_FAIL)
            printf("\n    collection_class");
        if (status_rec->coll_status_rec_2_u.data_warn.collection_state
== MGMT_FAIL)
            printf("\n    coll_state");
        return(0);
    }
    else if (status_rec->status != MGMT_SUCCESS) {
```

```

    printf("\nCall to add collection failed with status",
           status_rec->coll_status_rec_2_u.rc);
    xdr_free(xdr_coll_status_rec_2,status_rec);
    free(status_rec);
    return(0);
}
else
    printf("\nCall to add collection was executed");
    xdr_free(xdr_coll_status_rec_2,status_rec);
    free(status_rec);
    return(1);
}

```

In this example, the input record is prepared with key and data values, and then the call to add the row is performed.

Following the call to the add routine, the return record pointer is tested to ensure that it is not NULL (that is, that the call completed). Then the overall status code (`status_rec->status`) is checked to determine whether the add was performed.

A status value of `MGMT_WARN` indicates that some fields were in error, so individual return codes are tested to determine which fields were invalid.

A status value other than `MGMT_WARN` or `MGMT_SUCCESS` means a general error occurred. A value of `MGMT_SUCCESS` means the record was added.

## 6.9. Start, Stop, and Replace Procedures

These three types of procedures are similar in the way they are called and in the data that is returned to them, even though they do very different operations. Start and stop procedures are used to start or stop various ACMS processes; the replace procedure is used to replace a running procedure server in an application.

An exception is the call to the `acmsmgmt_stop_1` procedure, which requests the Remote Manager to shut down. For more information about the `acmsmgmt_stop_1` procedure, see Chapter 8.

For the rest of the start, stop, and replace procedures, an input record, which contains key data or startup or shutdown qualifier flags, is provided by the caller; the return data contains a status code and a linked list of status messages. Status messages are generated by `ACMSOPER` and are returned in their entirety. (Linked-list processing is illustrated in Section 6.5.1.)

All calls are synchronous.

See Chapter 8 for details about each call.

**Table 6.7. Start, Stop, and Replace Procedures**

Procedure	Description
<code>acmsmgmt_replace_server_1</code>	Key is application name and server name.
<code>acmsmgmt_start_acc_1</code>	No keys; specify auditing, QTI, and terminal disposition.
<code>acmsmgmt_start_exc_1</code>	Key is application name; no startup qualifiers.
<code>acmsmgmt_start_qti_1</code>	No keys or qualifiers.
<code>acmsmgmt_start_tsc_1</code>	No keys or qualifiers.

Procedure	Description
acmsmgmt_stop_acc_1	No keys; specify cancel disposition.
acmsmgmt_stop_exc_1	Key is application name; specify cancel disposition.
acmsmgmt_stop_qti_1	No keys or qualifiers.
acmsmgmt_stop_tsc_1	No keys or qualifiers.

## 6.9.1. Start Example

The following example code shows how a client program calls the `acmsmgmt_start_acc_1` procedure to start ACMS on a remote node. In this example, the QTI and TSC are started along with the system, and system auditing is enabled.

This example assumes client initialization has been performed as described in Section 6.3.

```
int start_acc(int client_id, CLIENT *cl)
{
    dcl_link      *nl;
    static acc_startup_rec start_struct;
    static cmd_output_rec *ret_struct;

    start_struct.client_id = client_id;
    start_struct.audit_sw = 1;
    start_struct.qti_sw = 1;
    start_struct.terminals_sw = 1;

    ret_struct = acmsmgmt_start_acc_1(&start_struct, cl);

    if (!ret_struct) {
        printf ("\n Call to start ACMS system failed");
        return(MGMT_FAIL);
    }

    if (ret_struct->status != MGMT_SUCCESS) {

        if (ret_struct->status != MGMT_WARN) {
            printf("\nCall to start ACMS system failed with status %d",
                ret_struct->status);
            xdr_free(xdr_cmd_output_rec, ret_struct);
            free(ret_struct);
            return(0);
        }

        printf("\n Call to start ACMS system completed with warnings or
            errors");

        for (nl = ret_struct->cmd_output_rec_u.data.cmd_output; nl !=
            NULL;
            nl = nl->pNext)
            printf("\n %s", nl->dcl_msg);
            xdr_free(xdr_cmd_output_rec, ret_struct);
            free(ret_struct);
        return(MGMT_FAIL);
    }
    else {
```

```
    printf("\nCall to start ACMS system was executed");
    for (nl = ret_struct->cmd_output_rec_u.data.cmd_output; nl !=
NULL;
        nl = nl->pNext)
        printf("\n %s",nl->dcl_msg);
    }
    xdr_free(xdr_cmd_output_rec, ret_struct);
    free(ret_struct);
return(0);
}
```

In this example, the input record is prepared with qualifier data, and then the call to start the system is performed. Auditing is enabled, and QTI and TSC will be started with the system.

The return value from the calls to the start, stop (except `acmsmgmt_stop_1`), and replace procedures is a pointer to a union. If the pointer returned is `NULL`, the call has failed. RPC error checking must be used to determine the cause of the error. If a valid pointer is returned, it points to a structure containing a union with the following structure:

```
union cmd_output_rec switch (int status) {
    case MGMT_WARN:
        cmd_rec data_warn;
    case MGMT_SUCCESS:
        cmd_rec data;
    case MGMT_FAIL:
        int rc;
    default:
        void;
};
```

The status field determines which structure is being returned. If the status is equal to `MGMT_FAIL`, the `rc` field is returned. The `rc` field contains a status code indicating the reason for failure.

If the status field is not equal to `MGMT_WARN` or `MGMT_SUCCESS`, a pointer to a linked list has been returned. The linked list contains a text field and a forward pointer. By following the forward pointers, all the records in the list can be retrieved. Section 6.5.1 illustrates how to follow the linked list.

In either case, the example code prints out the contents of all the strings in the linked list. These strings are status messages returned by `ACMSOPER`.



# Chapter 7. Management Programming Using SNMP

Programmers who want to access and maintain the ACMS Remote Manager from their own programs can use the following two interfaces:

- Open Network Computing (ONC) Remote Procedure Call (RPC)

The ONC RPC interface is for system managers and system programmers who want to write custom tools and applications that access the ACMS Remote Manager. For more information, see Chapter 6.

- Simple Network Management Protocol (SNMP)

The SNMP interface is provided for integration with enterprise management packages such as PATROL<sup>®</sup> from BMC<sup>®</sup> and Tivoli from IBM<sup>®</sup>.

This chapter discusses the SNMP interface. Programmers who are familiar with SNMP console programming can use this information when writing routines that interact with the ACMS Remote Manager using the SNMP protocol. The information in this chapter is also useful for programmers who are integrating the ACMS Remote Manager with other enterprise management packages through the SNMP protocol.

The ACMS Remote Manager implements the management information base (MIB) for SNMP. To access ACMS MIB information through SNMP, you must have an SNMP-enabled console (such as PATROL<sup>®</sup> from BMC<sup>®</sup>) or you can use an SNMP MIB browser such as the one provided by Compaq TCP/IP Services for OpenVMS, which includes the TCPIP\$SNMP\_REQUEST.EXE utility.

Alternatively, you can write your own SNMP interface. For more information about programming SNMP, refer to *Windows NT SNMP* by James D. Murray, published by O'Reilly & Associates, Inc., Sebastopol, CA.

## 7.1. SNMP Overview

The ACMS Remote Manager implements a MIB for ACMS. When the SNMP interface is enabled, either during or after Remote Manager process startup, it registers the ACMS subtree with the local SNMP master agent. SNMP console requests go first to the SNMP master agent (provided by the installed TCP/IP software, such as Compaq TCP/IP Services for OpenVMS), which in turn delivers them to the ACMS Remote Manager. Figure 7.1 illustrates the SNMP interface with the ACMS Remote Manager.

**Figure 7.1. SNMP Program Interface with Remote Manager**

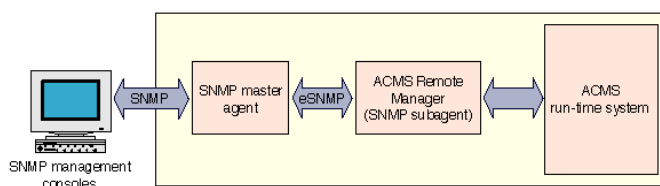

Communications between the SNMP interface and the master agent use the eSNMP protocol. This protocol is transparent to SNMP consoles.

The ACMS Remote Manager provides management information to SNMP management platforms in response to `snmp_get` and `snmp_getnext` messages. Management platforms can modify many management data elements by sending the appropriate `snmp_set` message. If any traps have been configured, the ACMS Remote Manager will generate SNMP traps when the Remote Manager detects a trap condition (for example, when an ACMS process starts or stops).

All Management table fields are available to SNMP management applications through get operations, but not all fields can be set. In general, the fields that can be set are Configuration class fields (in ACMS entity tables) and nearly all Manager configuration table fields. See Chapter 9 for a list of all tables and fields.

## 7.2. SNMP Security

Security for the SNMP interface is enforced first by the SNMP master agent (not the ACMS MIB). SNMP supports the concept of communities, which are essentially node inclusion lists. Whoever installs and configures the SNMP software package (typically the network manager) sets up SNMP communities. Nodes that are part of the SNMP community to which the subagent belongs can connect to the master agent; any node that can connect to the master agent can connect and interact with the subagent. All SNMP communities are allowed any combination of read, write, and trap access. Nodes that are not part of the community do not have access to the master agent.

Note that communities work at the node level only. It is not possible to restrict the access of individual user accounts on the node, although it may be possible to restrict access to the SNMP console software on a per-user basis. Note also that node authentication itself is relatively weak and provides no safeguards against masquerades or other forms of network deception.

As a second level of security, the ACMS Remote Manager requires that a special OpenVMS account (ACMS\$SNMP) be created for the SNMP interface on nodes on which the Remote Manager runs. The account must be granted OpenVMS rights for read, write, or operate access (or some combination of these) to Remote Manager data and functions. This allows ACMS system managers to grant read access, for instance, through the SNMP interface, but to prevent write or operate access. See Section 4.4 for a discussion of how to configure Remote Manager authentication and authorization for the SNMP interface.

## 7.3. Initializing the SNMP Interface

In order for SNMP consoles to communicate with the ACMS Remote Manager through SNMP, the Remote Manager SNMP interface must have been started. The SNMP interface runs as a separate thread in the Remote Manager and can be started or stopped at any time without restarting the Remote Manager.

The SNMP interface is started using the `SET INTERFACE` command. The current state of the interface can be determined using the `SHOW INTERFACE` command. Refer to Section 4.5 for more information about using `ACMSCFG` and `ACMSMGR` to start and stop interfaces.

During startup, the SNMP interface first performs some housekeeping tasks and then attempts to register with the SNMP master agent.

In order for the SNMP interface to initialize successfully, the following conditions must be met:

- The ACMS\$SNMP account on the Remote Manager node must exist.
- The ACMS\$MGMT\_READ, ACMS\$MGMT\_WRITE, and ACMS\$MGMT\_OPER rights identifiers must exist. At least one of these identifiers must be granted to the ACMS\$SNMP account.



- The SNMP master agent must be running on the Remote Manager node.

If any of the initialization tasks fail, or if registration fails, the SNMP interface writes error messages to the Remote Manager log and the thread exits. In this case, users should check the Remote Manager log for messages, correct the problem, and restart the interface.

During initialization, the Remote Manager establishes a timeout that the master agent will use when communicating with it. The timeout is based on the value of the Remote Manager parameter `SNMP_AGENT_TIME_OUT`.

If initialization is successful, the SNMP interface thread waits for incoming SNMP requests. The wait times out periodically (based on the Remote Manager parameters `SNMP_SEL_TIME_OUT` and `SNMP_ARE_YOU_THERE` stored in the Parameter table), and checks to make sure the SNMP master agent is still running by sending an “are you there” message to the master agent. If the master agent responds, the Remote Manager continues to wait for incoming messages. If the master agent does not respond, the SNMP interface thread attempts to restart the connection. If the restart fails, the SNMP thread exits.

## 7.4. SNMP Tables

The tables in Chapter 9 and the tables defined in the ACMS MIB map to each other on a one-to-one basis. However, data types are slightly different between SNMP and RPC, most significantly in the use of the gauge structure type. Section 7.4.1 describes data type mapping.

When accessing any of the ACMS MIB tables, it is important to keep in mind the dynamic nature of the ACMS run-time system. ACMS entities may be stopped and restarted; collection states for the entities may change dynamically; new processes (especially EXC and CPs) may be created. It is also important to understand that the size of some ACMS MIB tables may change when either the ACMS run-time system is restarted, or even as certain processes are started and stopped.

If the proper access strategies are not used when getting or setting ACMS MIB data, unpredictable and erroneous results can occur.

Different access strategies must be used for different types of tables. In the ACMS MIB, there are three types of tables. Specific access strategies for each table type are discussed in separate sections, as follows:

- Single-row tables (see Section 7.4.2)
- Static tables (see Section 7.4.3)
- Dynamic tables (see Section 7.4.4)

Also refer to Section 7.4.5 for a discussion of how the Server and Task Group tables are indexed.

Regardless of the type of table, identity and state validation should be performed for all ACMS entity tables (ACC, TSC, CP, QTI, EXC, server, task group).

Identity validation is performed by storing the PID field of the process occupying the row the first time the row is accessed. Then, when revisiting the table, get the PID along with the data values. Then check that the PID has not changed. If it has, the data refers to a new process.

Note that the process name is not a good means of identifying a process, because process names can be reused between entity executions.

Also note PID is not an ID class field for servers and task groups. For these two entity types, the EXC PID should be used.

State validation is performed by checking the collection state for the class that contains the field. For instance, if the `exc-current-waiting-tasks-num` (in the EXC run-time class) is being monitored, ensure that the `exc-rt-coll-state` is enabled (equal to 1). Otherwise, the value in that field is no longer being updated by the EXC, and is no longer accurate.

## 7.4.1. Data Type Mapping

The ACMS Remote Manager implements three data types:

- Integer
- String
- Gauge

The *integer* and *string* data types map directly to the SNMP INTEGER and DisplayString data types.

The *gauge* data type defined for the Remote Manager is not the same as the SNMP Gauge type. In order to avoid confusion, the Remote Manager SNMP interface maps the Remote Manager gauge fields to SNMP INTEGER and DisplayString data types. So for each Remote Manager *gauge* data type, three fields are defined in the MIB: the current field value, the maximum (or minimum) field value, and the maximum (or minimum) field value time.

For example, consider the ACC run-time field `current_appls`. This is defined as a Remote Manager *gauge* data type in Section 9.2. In the MIB, three fields are defined:

```
acc-current-appls-num          INTEGER ,
acc-current-appls-max          INTEGER ,
acc-current-appls-time         DisplayString
```

This is the case for all Remote Manager *gauge* data types. For Remote Manager *min gauge* data types, there is a `-min` field instead of a `-max` field. For both *gauge* data types, time is expressed in the form *DD-MMM-YYYY HH:MM:SS.hh*.

## 7.4.2. Single-Row Tables

Access to single-row tables is straightforward, because only a single row is ever accessed. The following are single-row tables:

- ACC table
- QTI table
- TSC table
- Parameter table
- Remote Manager table

Bounds checking need not be performed. However, for Entity tables (ACC, QTI, TSC), both identity and state validation must be performed.

## 7.4.3. Static Tables

Static tables are sized when the parent process starts and do not change as long as the parent process is running. For each static table, there is a field in the table of the parent process that indicates the upper bound of the static table.

Table 7.1 shows the static tables, their parent process, and the field that indicates the upper bound of the table.

**Table 7.1. Static Tables**

Table	Parent Process	Upper Bound (field and table)
CP	TSC	tsc-cp-slots-active in the TSC table
EXC	ACC	acc-max-appl-active in the ACC table
Server	EXC	exc-server-types in the EXC table
Task Group	EXC	exc-task-groups in the EXC table
Interfaces	Remote Manager	rmIfCt in the Remote Manager table
Collection	Remote Manager	totl-entity-slots in the Parameter table

In static tables, table data is not always contiguous and table rows can be reused. The PID field should be used to establish process identity.

For example, consider the following CP table. Assume that the first CP is permanent, and the second two are not.

Table Row	CP process name	CP PID
1	ACMS01CP001000	2040013D
2	ACMS01CP002000	2040013E
3	ACMS01CP003000	2040013F

An SNMP console searching this table sequentially would find all three CP instances; access to table row 4 would return an error. However, if the users attached to the CP in table row 2 log out, the CP terminates and the table now looks like this:

Table Row	CP process name	CP PID
1	ACMS01CP001000	2040013D
2		
3	ACMS01CP003000	2040013F

An SNMP console searching this table sequentially and stopping when the first error is returned would find only the first CP. Access to the second row would return an error. Therefore, when scanning static tables, it is important to examine all rows of the table before terminating the scan; that is, perform a loop based on the tsc-cp-slots-active field in the TSC table.

Finally, consider what happens if a new CP now starts. The table would look as follows:

Table Row	CP process name	CP PID
1	ACMS01CP001000	2040013D
2	ACMS01CP002000	20400140
3	ACMS01CP003000	2040013F

Table row 2 is now valid again, but a different process occupies it. Therefore, any cached information for table row 2 is invalid and must be refreshed with the data from the new process.

## 7.4.4. Dynamic Tables

Dynamic tables do not have a fixed upper bound; they grow and shrink as entries are added and removed. However, data in dynamic tables is always contiguous, so there are never invalid rows stored between valid rows. When a row becomes invalid because it is empty or unoccupied, it is removed from the table and the remaining rows are renumbered.

The following are dynamic tables:

- User table
- Log table
- Trap table

To see how a dynamic table changes when a table row is removed, assume that a user table has the following contents:

Table row	User Name	Client Id
1	User1	1
2	User2	2
3	User3	3
4	User4	4

If User2 logs out, the contents of the table would change as follows:

Table row	User Name	Client Id
1	User1	1
2	User3	3
3	User4	4

As with static tables, you must ensure that the table row being accessed has not been reused or renumbered. Among dynamic tables, only the Trap table allows updates. Note that entries are never deleted or modified in the Log table; new entries are always appended to the end.

## 7.4.5. Servers and Task Groups

The Servers and Task Group tables are indexed by a compound index. For both tables, the first key value is the table row of the owning EXC; the second key value is the Server or Task Group row. When fetching or setting Server or Task Group rows, you must first determine the EXC (application) they belong to, and then determine the particular server or task group.

For example, assume the EXC table has a total of four rows. Application Appl1 occupies row 1, and has two servers (ServerA and ServerB) and one task group (TaskGroupA). Application Appl2 occupies row 3 and has two servers (ServerC and ServerD) and two task groups (TaskGroupB, TaskGroupC). EXC table rows 2 and 4 are unused. Table 7.2 and Table 7.3 list the contents of each table.

**Table 7.2. EXC Table (OID 1.3.6.1.4.1.36.2.18.48.13)**

Row	Contents
1	Appl1
2	(unused)
3	Appl2

Row	Contents
4	(unused)

**Table 7.3. Server Table (OID 1.3.6.1.4.1.36.2.18.48.13)**

Key 1 (EXC)	Key 2 (Server)	Contents
1	1	ServerA
1	2	ServerB
3	1	ServerC
3	2	ServerD

**Table 7.4. Task Group Table (OID 1.3.6.1.4.1.36.2.18.48.13)**

Key 1 (EXC)	Key 2 (Task Group)	Contents
1	1	TaskGroupA
3	1	TaskGroupB
3	2	TaskGroupC

In order to access the ser-server-name field for ServerA in application Appl1, the OID would be 1.3.6.1.4.1.36.2.18.48.14.1.3.1.1 To access the same field for ServerD in Appl2, the OID would be 1.3.6.1.4.1.36.2.18.48.14.1.3.3.2.

There is no way to determine to which task group a server belongs. In contrast, you can always determine from the OID which application a server belongs to because ACMS requires that each server be given a unique name within the application.

## 7.5. SNMP GET Operations

SNMP get requests are satisfied at the time they are received by the subagent. Get requests can take one of three forms: get, get next, and get bulk.

- Get operations are simple requests for single data items.
- Get next requests are iterative requests for logically sequential information.
- Get bulk requests obtain a logical sequence of information in a single request.

The SNMP subagent for ACMS supports only the first operation. SNMP “walks”, if performed, return unpredictable results.

OID's for ACMS Management tables are documented in Section x.x (THIS SECTION IS TO BE DETERMINED).

## 7.6. SNMP SET Operations

SNMP set requests are executed at the time they are received by the subagent and are applied to the running system. However, not all fields that can be set are dynamic; the actual implementation of modification may not occur until the affected entities are restarted.

For more discussion about updates that modify the ACMS run-time system, see Section 5.3.

OIDs for ACMS Management tables are documented in the file MIB\_OID.LIS available from the directory ACMS\$RM\_EXAMPLES. The MIB definition for the ACMS subtree is provided in the ACMS\$RM\_EXAMPLES directory in file MGMTMIB.MY.

In order for SNMP set requests to complete successfully, the following conditions must be met:

- The ACMS\$SNMP account on the Remote Manager node must be granted the ACMS \$MGMT\_WRITE or ACMS\$MGMT\_OPER identifier, depending on the operation being performed (see Appendix B).
- The SNMP interface must already be started.
- The ACMS run-time system must already be started (to update ACMS entity information).

General eSNMP return codes for SNMP get requests are returned from the Remote Manager (see Section 7.10). For details about a specific error, refer to the Remote Manager log.

## 7.7. Using SNMP to Start and Stop ACMS Entities

To start and stop ACMS entities (or to stop the Remote Manager), the Remote Manager allows SNMP users to modify the ID class field `running_state`. In general, ID class fields are read only. However, since SNMP does not support a START or STOP command, the SET command must be used.

Modifications to the `running_state` fields are not performed directly by the Remote Manager. Instead, the Remote Manager uses ACMSOPER commands to request the shutdown or startup of the ACMS entity. The ACMS entities update the `running_state` field when they start or stop.

For instance, to start the ACMS run-time system, an SNMP console program issues an SNMP SET command for the ACC `running_state` OID, specifying the value “started”. The Remote Manager interprets this message as an attempt to start the system and issues the appropriate ACMSOPER command.

The SNMP set call is synchronous. That is, it does not complete until the ACMS operation has completed.

Failure messages related to start or stop requests are written to the Remote Manager log.

## 7.8. SNMP Traps

SNMP traps provide a means of automatically notifying the system support team when a warning or error condition exists. Users configure SNMP traps in the SNMP trap table; however, note that traps are not generated unless a corresponding entry exists in the entity/collection table. Refer to the *Data Abstraction* for the contents of each of these tables.

At runtime, SNMP traps can be generated either as the result of an error event occurring (i.e. a new entry being made in the Class 6 table), or if a monitored parameter exceeds (or falls below) a user defined threshold. The SNMP interface will monitor both sources of data, and will generate traps accordingly. Note that SNMP traps themselves will result in error records being written, but are not themselves trappable.

Error events are inspected at the time they are detected by the error collection routines to determine if a trap should be generated or not. Thresholds are checked on a user defined interval to determine

if a trap should be generated or not. For both sources of traps, a gating factor is used to prevent a persistent error from flooding the system. After  $n$  number of consecutive alarms (where  $n$  is the gating factor), the monitoring interval is continuously doubled, until the error condition does not re-occur. As a matter of implementation, monitoring of the value is not suspended when the interval is doubled. Instead, traps are discarded for the duration of the inflated monitoring interval.

It is possible to have SNMP traps generated for the following events: SNMP trap table; when a matching condition or event occurs, an SNMP trap is generated. SNMP management consoles listen for SNMP traps and then respond in a console-dependent (and usually user-configurable) manner.

See Section 9.13 for a discussion of the Trap table and the format of trap messages.

At run time, SNMP traps can be generated as the result of either an ACMS process starting or stopping, or an event that occurred within the Remote Manager (for example, a failure in communications with ACMS).

ACMS system managers configure traps by modifying the Trap table, either by using the ACMSCFG utility prior to Remote Manager startup or by using the ACMSMGR utility after the Remote Manager has been started. Changes made using ACMSCFG do not affect the running system until the Remote Manager is restarted; changes made using ACMSMGR are not saved when the Remote Manager stops.

The configuration process is the same with either utility. You use the ADD TRAP command to add new traps, use the DELETE TRAP command to remove traps, and use the SET TRAP command to modify traps.

Keep in mind that although you can add, delete, or modify entries in the trap table at almost any time, traps will not be generated unless the SNMP interface is started. In addition, traps are not queued if the SNMP interface is disabled.

The combination of entity, name, and parameter uniquely identify a trap in the Trap table. For each trap, a minimum and a maximum value can be specified, along with a severity. Minimum and maximum trap values specify thresholds that trigger traps when the associated parameter is either greater than or less than the threshold. Minimum and maximum trap values are parameter specific.

A special value of -1 is used as a placeholder when creating a trap for which a minimum or maximum does not apply. In many situations, only the minimum or maximum value setting is meaningful. In this instance, set the desired field (minimum or maximum) to the threshold value, and set the other to -1.

Two trap parameters are supported:

- EXISTS (see Section 7.8.1)
- EVENT\_SEVERITY (see Section 7.8.2)

### 7.8.1. EXISTS Traps

The trap parameter EXISTS allows traps to be generated based on whether an ACMS process starts or stops.

Specifying a minimum trap value of 1 for a process specifies, in effect, that a trap should be generated whenever the process stops — that is, when the process existence is less than 1.

Specifying a maximum value of 0 specifies that a trap should be generated whenever the process starts — that is, when the processes existence is greater than 0.

A minimum value of 0 or a maximum value of 1, while valid, is basically useless, since the EXISTS parameter is never greater than 1 or less than 0.

## 7.8.2. EVENT\_SEVERITY Traps

The trap parameter EVENT\_SEVERITY allows traps to be generated based on the facility and severity of events being logged to the Remote Manager log. For example, an EVENT\_SEVERITY trap can be configured for Remote Manager SNMP events with severity higher than WARNING (such as ERROR or FATAL). Any time a Remote Manager SNMP operation fails with a severity higher than WARNING, an SNMP trap is generated.

Other facilities that can be monitored are:

- \* (all)
- MGR (Remote Manager main process)
- PROCMON (process monitor thread)
- RPC (RPC interface thread)
- SNMP (SNMP interface thread)
- SEC (security routines)
- LOG (event logging thread)
- TIMER (internal timer thread)
- DCL (DCL subprocess management thread)
- MSG\_PROC (processes incoming ACMS errors)
- TRAP (trap sender thread)

Use care when you configure traps so that you do not create unnecessary traps. In general, traps are intended to be used to signal significant events. For instance, specifying a minimum severity of FATAL or ERROR causes all informational and warning messages to generate traps. This is probably not a good use of network or console resources.

## 7.9. SNMP Debug Tracing

In addition to the normal logging the Remote Manager performs, it is possible to enable debug-level SNMP tracing. This level of tracing is performed by the eSNMP TCP/IP code layer and may not be available for all TCP/IP products. The *Compaq TCP/IP Services for OpenVMS* product supports debug-level SNMP tracing. If you use a third-party TCP/IP product, check with that vendor regarding support for this option.

Debug-level tracing of the Remote Manager SNMP interface can be valuable for developing SNMP console applications or for trying to debug a particular SNMP environmental problem. However, it is relatively resource intensive and should be performed in a controlled environment for short durations.

To enable debug-level SNMP tracing, the Remote Manager must be started with the command line argument LOG\_TO\_SYSOUT, as follows:

```
@sys$startup:acms$mgmt_startup LOG_TO_SYSOUT
```



The `SNMP_AUDIT_LEVEL` parameter must be greater than 0. When the SNMP interface is started, it will enable debug-level tracing in the eSNMP code layer. All output is directed to `SYSS$OUTPUT` for the Remote Manager process, which is redirected by the startup command procedure to `SYSS$ERRORLOG:ACMS$MGMT_SERVER.OUT`.

## 7.9.1. Starting SNMP Debug Tracing

To start the Remote Manager with debug-level SNMP tracing, run the startup command procedure `SYSS$STARTUP:ACMS$MGMT_STARTUP`, specifying `LOG_TO_SYSOUT` as the only parameter to the command procedure, as follows:

```
$ @SYSS$STARTUP:ACMS$MGMT_STARTUP LOG_TO_SYSOUT
```

Once the Remote Manager has been started and the SNMP interface has been enabled, make sure that the `SNMP_AUDIT_LEVEL` parameter is greater than 0. To do this, use the following `ACMSMGR` command:

```
$ ACMSMGR SET PARAM/SNMP_AUDIT_LEVEL=F
```

The SNMP debug output is written to `SYSS$ERRORLOG:ACMS$MGMT_SERVER.OUT`, which is an ASCII file that can be typed or edited.

## 7.9.2. Stopping SNMP Debug Tracing

To stop debug-level SNMP tracing, either restart the Remote Manager (without the `LOG_TO_SYSOUT` parameter), or use the following command to set the `SNMP_AUDIT_LEVEL` parameter to 0:

```
$ ACMSMGR SET PARAM/SNMP_AUDIT_LEVEL=0
```

# 7.10. Remote Manager eSNMP Return Codes

Table 7.5 describes the return codes returned by the Remote Manager eSNMP routines.

**Table 7.5. Remote Manager eSNMP Routines Return Codes**

Return Code	Description
<code>ESNMP_MTHD_commitFailed</code>	An attempt to apply an update failed. This is also returned from a start or stop attempt that fails. Refer to the Remote Manager log for details.
<code>ESNMP_MTHD_genErr</code>	An internal error occurred. This could be due to security violations, a failure updating a particular field, or an internal processing error. Refer to the Remote Manager log for details.
<code>ESNMP_MTHD_noCreation</code>	The table does not allow new rows to be created. The OID specified for the set operation indicates a table row that does not exist, and the table does not allow new rows to be created.
<code>ESNMP_MTHD_noError</code>	The set operation was successful.
<code>ESNMP_MTHD_noSuchInstance</code>	A request was made for a variable that does not exist. Either the OID is invalid, or the particular table row does not exist (is out of bounds).

<b>Return Code</b>	<b>Description</b>
ESNMP_MTHD_noSuchObject	The column specified does not exist.
ESNMP_MTHD_notWritable	An attempt was made to set a variable that is read only.
ESNMP_MTHD_resourceUnavailable	The table row exists (is within the bounds of the table ) but is currently unused (empty ).
ESNMP_MTHD_wrongValue	An attempt was made to update a field with an invalid value.

---

# Part II. Reference Information

Part II contains reference information for the ACMS Remote Manager.

---

# Chapter 8. Management APIs

The Management APIs are intended to be called from Open Network Computing (ONC) Remote Procedure Call (RPC) clients. ONC RPC Interface Definition Language (IDL) for all procedures is contained in the file `ACMS$RM_EXAMPLES:ACMSMGMT_RPC.X`.

Programmers who write client programs are strongly urged to become familiar with the contents of this file. Many programming questions can be answered by looking at the actual RPC definitions. All structure definitions, for example, are contained within this file.

---

## Note

The `acms$mgmt_get_creds` procedure is not included in the `ACMSMGMT_RPC.X` IDL because it is not a remote procedure call. It is a statically linked, locally executed function for those clients performing explicit authentication. The `ACMS$MGMT_GET_CREDENTIALS.OBJ` object module is located in the `ACMS$RM_EXAMPLES` directory.

The `acms$mgmt_get_creds` procedure is for use by ONC RPC clients only.

---

## 8.1. Common RPC Fields

The tables in this section list commonly used fields and their values.

### 8.1.1. Collection Classes

Table 8.1 shows the symbolic names for Remote Manager collection classes.

**Table 8.1. Collection Classes**

Symbolic Name	Description
<code>MGMT_CLASS_ALL</code>	All classes
<code>MGMT_CLASS_CFG</code>	Config class
<code>MGMT_CLASS_ID</code>	ID class
<code>MGMT_CLASS_POOL</code>	Pool class
<code>MGMT_CLASS_RT</code>	Runtime class

### 8.1.2. Interface Types

Table 8.2 shows the symbolic names for Remote Manager interfaces.

**Table 8.2. Interface Types**

Symbolic Name	Description
<code>MGMT_IF_RPC</code>	Remote Procedure Call (RPC) interface
<code>MGMT_IF_SNMP</code>	Simple Network Management Protocol (SNMP) interface

### 8.1.3. Enable States

shows the symbolic names for Remote Manager enable states.

**Table 8.3. Enable States**

Symbolic Name	Description
MGMT_STATE_DISABLED	Disabled
MGMT_STATE_ENABLED	Enabled

## 8.1.4. Entity Types

Table 8.4 shows the symbolic names for Remote Manager entity types.

**Table 8.4. Entity Types**

Symbolic Name	Description
MGMT_ACC	Application Central Controller (ACC ) process
MGMT_ALL	All entities
MGMT_CP	Command Process (CP ) process
MGMT_EXC	Application Execution Controller (EXC ) process
MGMT_MGR	Remote Manager process
MGMT_QTI	Queued Task Initiator (QTI ) process
MGMT_SER	Procedure server types
MGMT_TG	Task groups
MGMT_TSC	Terminal Subsystem Controller (TSC ) process
MGMT_UNSUPPORTED	Null value

## 8.1.5. Facility Types

Table 8.5 shows the symbolic names for Remote Manager facility types.

**Table 8.5. Facility Types**

Symbolic Name	Description
MGMT_FAC_ALL	Any facility type.
MGMT_FAC_DCL	A thread that manages a spawned DCL process. The DCL process is used to execute ACMSOPER commands.
MGMT_FAC_LOG	The event log writer thread.
MGMT_FAC_MGR	The mainline Remote Manager process.
MGMT_FAC_MSGPROC	A thread that handles messages coming in from ACMS processes.
MGMT_FAC_PROCMON	A thread dedicated to monitoring processes.
MGMT_FAC_RPC	The RPC interface thread (listener and procedures ).
MGMT_FAC_SEC	Security routines in the Remote Manager.
MGMT_FAC_SNMP	The SNMP interface thread (message loop and procedures ).

Symbolic Name	Description
MGMT_FAC_TIMER	A thread that controls timers for the Remote Manager.
MGMT_FAC_TRAP	A thread that sends out SNMP traps.

## 8.1.6. Running States

Table 8.6 shows the symbolic names for Remote Manager running states.

**Table 8.6. Running States**

Symbolic Name	Description
MGMT_STATE_INITED	Process or object has initialized.
MGMT_STATE_INITING	Process or object is initializing.
MGMT_STATE_LOAD_DONE	Process or object has finished loading.
MGMT_STATE_LOADING	Process or object is loading itself.
MGMT_STATE_STARTED	Process or object has started and is ready to run.
MGMT_STATE_STARTING	Process or object is starting the mainline.
MGMT_STATE_STOPPED	Process or object is stopped.

## 8.1.7. Severity Codes

Table 8.7 shows the symbolic names for Remote Manager severities.

Severities are generally reported as simple severities (informational, warning, error, fatal) but may be combined by logically ORing the values when used as selection criteria (such as for selecting log records).

**Table 8.7. Severity Codes**

Symbolic Name	Description
MGMT_SEV_ERR	Error
MGMT_SEV_FATAL	Fatal
MGMT_SEV_INFO	Informational
MGMT_SEV_NONE	Null value
MGMT_SEV_WARN	Warning

## 8.1.8. Trap Parameters

The table below shows the symbolic names for Remote Manager trap parameters.

**Table 8.8. Trap Parameters**

Symbolic Name	Description
MGMT_EXISTS	Existence traps
MGMT_SEVERITY	Remote Manager severity traps

## 8.2. Thread-Safe and Non-Thread Safe Clients

Each of the procedures documented in this chapter (and those in `ACMS$MGMT_EXAMPLES.C`) are designed to use the thread-safe client stub provided with the Remote Manager, as described in the file `ACMS$MGMT_EXAMPLES_BUILD.COM`. As a result, each procedure contains one or more "free" calls that prevent memory leaks in multithreaded client implementations.

If you intend to build a multithreaded client, you must modify any existing, customized API functions to include these calls, then recompile them along with the thread-safe client stub.

If you want to implement a non-thread safe client using the RPC-generated stub, omit the "free" calls. See `ACMS$MGMT_EXAMPLES_BUILD.COM` for detailed build instructions.

## 8.3. ACMSMGMT\_ADD\_COLLECTION\_2

### ACMSMGMT\_ADD\_COLLECTION\_2

`ACMSMGMT_ADD_COLLECTION_2` — This procedure adds entries to the Remote Manager Collection table. Collection table entries can also be modified and deleted.

#### Format

```
coll_status_rec_2 *acmsmgmt_add_collection_2(coll_config_rec_2 *set_struct, CLIENT *cl)
```

#### Parameters

##### set struct

Type:	Coll_config_rec_2	
Access:	Read	
Mechanism:	By reference	
Usage:	Structure that contains the following client identification and Collection table fields.	
	<b>client_id</b>	
	Type:	Integer
	Access:	Read
	Mechanism:	By value
	Usage:	If explicit authentication is being used, a valid client ID must be provided. If the value for <code>client_id</code> is 0, proxy access is used. <code>client_id</code> is obtained by calling the <code>acms\$mgmt_get_creds</code> procedure.
	<b>coll</b>	
	Type:	Coll_update_rec_r_2



Access:	Read
Mechanism:	By value
Usage:	Structure containing a Collection table record. Collection table fields are described in Section 9.4. See the Description section for information on how to initialize this record.

**cl**

Type:	CLIENT *
Access:	Read
Mechanism:	By value
Usage:	Pointer to an RPC client handle previously obtained by calling the RPC routine CLNT_CREATE.

**Return Value**

Type:	Coll_status_rec_2																				
Access:	write																				
Mechanism:	By reference																				
Usage:	<p>Pointer to a record that contains a union consisting of either a failure code or a structure of type coll_update_rec_r_2, which contains status codes for each field. See the Description section for a discussion of how to determine the update status for any field. The following are the contents of this union:</p> <table border="1"> <tr> <td colspan="2"><b>status</b></td> </tr> <tr> <td>Type:</td> <td>Integer</td> </tr> <tr> <td>Access:</td> <td>write</td> </tr> <tr> <td>Mechanism:</td> <td>By value</td> </tr> <tr> <td>Usage:</td> <td>Failure return code.</td> </tr> <tr> <td colspan="2"><b>data_warn</b></td> </tr> <tr> <td>Type:</td> <td>Coll_output_rec_r_2</td> </tr> <tr> <td>Access:</td> <td>write</td> </tr> <tr> <td>Mechanism:</td> <td>By value</td> </tr> <tr> <td>Usage:</td> <td>Structure containing a Collection table record. The entries in this field contain status codes corresponding to the fields in the coll structure. See the Description section for a discussion of how to determine the update status for any field.</td> </tr> </table>	<b>status</b>		Type:	Integer	Access:	write	Mechanism:	By value	Usage:	Failure return code.	<b>data_warn</b>		Type:	Coll_output_rec_r_2	Access:	write	Mechanism:	By value	Usage:	Structure containing a Collection table record. The entries in this field contain status codes corresponding to the fields in the coll structure. See the Description section for a discussion of how to determine the update status for any field.
<b>status</b>																					
Type:	Integer																				
Access:	write																				
Mechanism:	By value																				
Usage:	Failure return code.																				
<b>data_warn</b>																					
Type:	Coll_output_rec_r_2																				
Access:	write																				
Mechanism:	By value																				
Usage:	Structure containing a Collection table record. The entries in this field contain status codes corresponding to the fields in the coll structure. See the Description section for a discussion of how to determine the update status for any field.																				

## Description

This procedure adds a row to the Collection table (see Section 9.4).

Additions to this table are not durable; that is, they do not survive a restart of the Remote Manager. To make nondynamic, permanent updates to the Collection table, use the ACMSCFG utility.

Calls to this procedure must specify `entity_type`, `entity_name`, and `collection_class`. The combination of these fields must be unique within the collection table for the row to be added. Tables above contain symbolic values used to populate the `entity_type` and `collection_class` fields; `entity_name` is specified as a null-terminated string.

ID and Config class rows cannot be added. By default, these classes are always enabled for all ACMS processes.

The Collection table contains a fixed number of rows, which is determined by the Remote Manager parameter `total_entity_slots`. This is a nondynamic parameter and requires a restart of the ACMS system in order to be changed. The default is 20 rows.

Additions to the Collection table are processed immediately, and may affect more than one ACMS process.

## Example

```
int add_collection_data(int client_id, CLIENT *cl)
{
    static char c_name_all[] = "*";
    static coll_config_rec_2    set_struct;
    static coll_status_rec_2   *status_rec;

    set_struct.client_id        = client_id;
    set_struct.coll.entity_type = MGMT_ALL;
    set_struct.coll.entity_name = c_name_all;
    set_struct.coll.collection_class = MGMT_CLASS_RT;
    set_struct.coll.collection_state = MGMT_STATE_DISABLED;

    status_rec = acmsmgmt_add_collection_2(&set_struct, cl);

    if (!status_rec) {
        printf("\n Call to add collection failed");
        return(MGMT_FAIL);
    }

    if (status_rec->status == MGMT_WARN) {
        printf("\nThe following updates failed: ");
        if (status_rec->coll_status_rec_2_u.data_warn.entity_type ==
MGMT_FAIL)
            printf("\n    entity type invalid");
        if (status_rec->coll_status_rec_2_u.data_warn.collection_state
            == MGMT_FAIL)
            printf("\n    coll_state invalid");
        if (status_rec->coll_status_rec_2_u.data_warn.storage_state ==
MGMT_FAIL)
            printf("\n    storage_state invalid");
        if (status_rec->coll_status_rec_2_u.data_warn.storage_interval
            == MGMT_FAIL)
```

```

        printf("\n      storage_interval invalid");
    }
    else if (status_rec->status != MGMT_SUCCESS) {
        printf("\nCall to add collection with status %d",
            status_rec->coll_status_rec_2_u.rc);
        xdr_free(xdr_coll_status_rec_2, status_rec);
        free(status_rec);
        return(MGMT_FAIL);
    }
    else
        printf("\nCall to add collection was executed");
        xdr_free(xdr_coll_status_rec_2, status_rec);
        free(status_rec);
    return(0);
}

```

In the preceding example, the `ACMSMGMT_ADD_COLLECTION_2` procedure is called to add a row to the Collection table. The row added is for entity type of \* (all), entity name of \* (all), and collection class RUNTIME. The collection state is set to DISABLED. If the call succeeds, a Collection table row is added, and the RUNTIME collection state for some processes may be disabled. Otherwise, an error message is displayed.

## ACMSMGMT\_ADD\_ERR\_FILTER\_2

`ACMSMGMT_ADD_ERR_FILTER_2` — This procedure adds entries to the ACMS Error Filter table. Error Filter table entries can also be deleted.

### Format

```

error_filter_config_rec_r_2 *acmsmgmt_add_err_filter_2(err_filter_config_rec_r_2
*err_filter_cfg_rec, CLIENT *cl2)

```

### Parameters

#### `err_filter_cfg_rec`

Type:	Err_filter_config_rec_r_2	
Access:	Read	
Mechanism:	By reference	
Usage:	Structure that contains the following client identification and Error Filter table fields.	
	<b>client_id</b>	
	Type:	Integer
	Access:	Read
	Mechanism:	By value
	Usage:	If explicit authentication is being used, a valid client ID must be provided. If the value of <code>client_id</code> is 0, proxy

	access is used. Client_id is obtained by calling the acms \$mgmt_get_creds procedure.
<b>error_code</b>	
Type:	Integer
Access:	Read
Mechanism:	By value
Usage:	Structure containing an Error Filter table record. Error Filter table fields are described in Section 9.4. See the Description section for information on how to initialize this record.

**cl2**

Type:	CLIENT *
Access:	Read
Mechanism:	By value
Usage:	Pointer to an RPC client handle previously obtained by calling the RPC routine CLNT_CREATE.

**Return Value**

Type:	Err_filter_status_rec
Access:	Write
Mechanism:	By reference
Usage:	Pointer to a record that contains a union consisting of either a failure code or a structure of type err_filter_update_rec_r, which contains status codes for each field. See the Description section for a discussion of how to determine the update status for any field. The following are the contents of this union:
<b>status</b>	
Type:	Integer
Access:	Write
Mechanism:	By value
Usage:	Failure return code.
<b>data_warn</b>	
Type:	Err_filter_update_rec_r
Access:	Write
Mechanism:	By value
Usage:	Structure containing an Error Filter table record. The entries

	in this field contain status codes corresponding to the fields in the <code>err_filter_entry</code> structure. See the Description section for a discussion of how to determine the update status for any field.
--	--

## Description

This procedure adds a row to the Error Filter table.

Additions to this table are durable; that is, they do survive a restart of the Remote Manager.

Calls to this procedure must specify a valid `message_code` for the row to be added.

The Error Filter table is dynamic and does not have a fixed upper boundary. The size of the table fluctuates as entries are added and deleted. When a row becomes empty or unoccupied, it is removed and the remaining rows are renumbered.

Additions to the Error Filter table are processed immediately, and may affect more than one ACMS process.

## Example

```
int add_err_filter(int client_id, CLIENT *cl2)
{
    int *status;
    err_filter_config_rec_r_2 set_struct;

    set_struct.client_id          = client_id;
    set_struct.err_code           = 16637820;

    status = acmsgmt_add_err_filter_2(&set_struct, cl2);

    if (!status) {
        printf("\n Call to add filter failed");
        return(MGMT_FAIL);
    }

    if (*status != MGMT_SUCCESS) {
        printf("\nCall to add error filter failed with status %d", *status);
        free(status);
        return(MGMT_FAIL);
    }
    else {
        printf("\nCall to add error filter was executed");
    }
    free(status);
    return(0);
}
```

In the preceding example, the `acmsgmt_add_err_filter_2` procedure is called to add a row to the Error Filter table. If the call succeeds, the filter is added to the Error Filter table. Otherwise, an error message is displayed.

## ACMSMGMT\_ADD\_TRAP\_1

ACMSMGMT\_ADD\_TRAP\_1 — This procedure adds entries to the Remote Manager Trap table. Trap table entries can also be modified and deleted.

### Format

```
trap_status_rec *acmsmgmt_add_trap_1(trap_config_rec *set_struct, CLIENT *cl)
```

### Parameters

#### set\_struct

Type:	Trap_config_rec	
Access:	Read	
Mechanism:	By reference	
Usage:	Structure that contains the following client identification and Trap table fields.	
	<b>client_id</b>	
	Type:	Integer
	Access:	Read
	Mechanism:	By value
	Usage:	If explicit authentication is being used, a valid client ID must be provided. If the value of client_id is 0, proxy access is used. Client_id is obtained by calling the acms \$mgmt_get_creds procedure.
	<b>trap_entry</b>	
	Type:	Trap_update_rec_r
	Access:	Read
	Mechanism:	By value
	Usage:	Structure containing a Trap table record. See the Description section for information on how to initialize this record.

#### cl

Type:	CLIENT *
Access:	Read
Mechanism:	By value

Usage:	Pointer to an RPC client handle previously obtained by calling the RPC routine CLNT_CREATE.
--------	---

## Return Value

Type:	Trap_status_rec	
Access:	Write	
Mechanism:	By reference	
Usage:	<p>Pointer to a record that contains a union consisting of either a failure code or a structure of type trap_update_rec_r, which contains status codes for each field. See the Description section for a discussion of how to determine the update status for any field. The following are the contents of this union:</p>	
<b>status</b>		
Type:	Integer	
Access:	Write	
Mechanism:	By value	
Usage:	Failure return code.	
<b>data_warn</b>		
Type:	Trap_update_rec_r	
Access:	Write	
Mechanism:	By value	
Usage:	Structure containing a Trap table record. The entries in this field contain status codes corresponding to the fields in the trap_entry structure. See the Description section for a discussion of how to determine the update status for any field.	

## Description

This procedure adds a row to the Trap table.

Additions to this table are not durable; that is, they do not survive a restart of the Remote Manager. To make nondynamic, permanent updates to the Trap table, use the ACMSCFG utility.

Calls to this procedure must specify entity\_type, entity\_name, and param\_to\_trap. The combination of these fields must be unique within the Trap table for the row to be added. Table 8-1 and Table 8-4 contain symbolic values used to populate the collection\_class and entity\_type fields.

Setting fields trap\_min, trap\_max and/or severity to -1 causes them to be ignored when trap conditions are evaluated at run time. Otherwise, they must contain valid values for the row to be added (trap\_min and trap\_max must be position numbers; severity must be one of the valid severities).

Additions to the Trap table are processed immediately, and may affect more than one ACMS process.

The size of the Trap table is unbounded.

## Example

```
int add_trap_data(int client_id, CLIENT *cl)
{
    static char c_name_all[2] = "*";
    static trap_config_rec    set_struct;
    struct trap_status_rec    *status_rec;

    set_struct.client_id      = client_id;
    set_struct.trap_entry.entity_type    = MGMT_ACC;
    set_struct.trap_entry.entity_name    = c_name_all;
    set_struct.trap_entry.param_to_trap = MGMT_EXISTS;
    set_struct.trap_entry.min           = -1;
    set_struct.trap_entry.max           = 0;
    set_struct.trap_entry.severity      = MGMT_SEV_ERR;

    status_rec = acmsmgmt_add_trap_1(&set_struct, cl);

    if (!status_rec) {
        printf("\n Call to add trap failed");
        return(MGMT_FAIL);
    }

    if (status_rec->status == MGMT_WARN) {
        printf("\nThe following fields are invalid: ");
        if (status_rec->trap_status_rec_u.data_warn.entity_type ==
MGMT_FAIL)
            printf("\n    entity_type not found or invalid");
        if (status_rec->trap_status_rec_u.data_warn.param_to_trap ==
MGMT_FAIL)
            printf("\n    param not found or invalid");
        if (status_rec->trap_status_rec_u.data_warn.min == MGMT_FAIL)
            printf("\n    min invalid");
        if (status_rec->trap_status_rec_u.data_warn.max == MGMT_FAIL)
            printf("\n    max invalid");
        if (status_rec->trap_status_rec_u.data_warn.severity == MGMT_FAIL)
            printf("\n    severity invalid");
    }
    else if (status_rec->status != MGMT_SUCCESS) {
        printf("\nCall to add trap failed with status %d",
            status_rec->trap_status_rec_u.rc);
        xdr_free(xdr_trap_status_rec, status_rec);
        free(status_rec);
        return(MGMT_FAIL);
    }
    else
        printf("\nCall to add trap was executed");
        xdr_free(xdr_trap_status_rec, status_rec);
        free(status_rec);
    return(0);
}
```

In the preceding example, the ACMSMGMT\_ADD\_TRAP\_1 procedure is called to add a row to the Trap table. The new row will contain an entity type of ACC, an entity name of \* (all), and a trap parameter of EXISTS. The value of the trap\_min field is -1 (ignored), and the value of the trap\_max



field is 0. The severity of the trap will be error. The effect of this addition is to cause an error-level trap to be generated whenever the ACC is started on the target node. If the call succeeds, the trap is added to the Trap table. Otherwise, an error message is displayed.

## ACMSMGMT\_DELETE\_COLLECTION\_1

ACMSMGMT\_DELETE\_COLLECTION\_1 — This procedure deletes entries from the Remote Manager Collection table. Collection table entries can also be added and updated.

### Format

```
int *acmsmgmt_delete_collection_1(coll_del_rec *set_struct,CLIENT *cl)
```

### Parameters

#### set\_struct

Type:	Coll_del_rec	
Access:	Read	
Mechanism:	By reference	
Usage:	Structure that contains the following client identification and Collection table fields.	
	<b>client_id</b>	
Type:	Integer	
Access:	Read	
Mechanism:	By value	
Usage:	If explicit authentication is being used, a valid client ID must be provided. If the value for client_id is 0, proxy access is used. Client_id is obtained by calling the acms \$mgmt_get_creds procedure.	
	<b>entity_type</b>	
Type:	Integer	
Access:	Read	
Mechanism:	By value	
Usage:	The type of ACMS entity the process is.	
	<b>entity_name</b>	
Type:	Null-terminated string	
Access:	Read	

	Mechanism:	By reference
	Usage:	Pointer to a character string containing a full or partial entity name. May contain wildcard characters (*, !).
<b>collection_class</b>		
	Type:	Integer
	Access:	Read
	Mechanism:	By value
	Usage:	The type of collection class to delete.

**cl**

Type:	CLIENT *
Access:	Read
Mechanism:	By value
Usage:	Pointer to an RPC client handle previously obtained by calling the RPC routine CLNT_CREATE.

**Return Value**

Type:	Integer
Access:	Write
Mechanism:	By reference
Usage:	Pointer to a status code containing a success or failure status code. MGMT_SUCCESS indicates success. Other values indicate failure.

**Description**

This procedure deletes a row from the Collection table.

Calls to this procedure must specify `entity_type`, `entity_name`, and `collection_class`. The combination of these fields must exactly match an existing row in the table for the row to be deleted. Table 8-1 and Table 8-4 contain symbolic values used to populate the `collection_class` and `entity_type` fields; `entity_name` is specified as a null-terminated string.

ID and CONFIG class rows cannot be deleted.

The Collection table contains a fixed number of rows, which is determined by the Remote Manager Parameter table field `total_entity_slots`. This is a nondynamic parameter and requires a restart of the ACMS system in order to be changed. The default is 20 rows. When a row is deleted, it becomes immediately available for reuse.

Deletions from the collection table are processed immediately, and may affect more than one ACMS process.

## Example

```
int delete_collection_data(int client_id,CLIENT *cl)
{
    static char c_name_all[] = "*";
    static coll_del_rec set_struct;
    int *status;

    set_struct.client_id      = client_id;
    set_struct.entity_type    = MGMT_ALL;
    set_struct.entity_name    = c_name_all;
    set_struct.collection_class = MGMT_CLASS_RT;

    status = acmsmgmt_delete_collection_1(&set_struct,cl);

    if (!status) {
        printf("\n Call to delete collection failed");
        return(MGMT_FAIL);
    }

    if (*status != MGMT_SUCCESS) {
        printf("\n Call to delete collection failed with status
%d",*status);
        free (status);
        return(MGMT_FAIL);
    }
    else
        printf("\nCall to delete collection was executed");
        free (status);
        return(0);
}
```

In the preceding example, the `ACMSMGMT_DELETE_COLLECTION_1` procedure is called to delete a row from the Collection table. The row deleted is for entity type of \* (all), entity name of \* (all), and a collection class of RUNTIME. If the call succeeds, the collection table row is deleted, and the RUNTIME collection state for some processes may be changed depending on the collection state of the row before it was deleted. Otherwise, an error message is displayed.

## ACMSMGMT\_DELETE\_ERR\_FILTER\_2

`ACMSMGMT_DELETE_ERR_FILTER_2` — This procedure deletes entries from the Remote Manager Error Filter table. Error Filter table entries can also be added.

### Format

```
int *acmsmgmt_delete_err_filter_2(err_del_rec *set_struct,CLIENT *cl2)
```

### Parameters

#### set\_struct

Type:	Err_del_rec
Access:	Read
Mechanism:	By reference

Usage:	Structure that contains the following client identification and Error Filter table fields.	
	<b>client_id</b>	
Type:	Integer	
Access:	Read	
Mechanism:	By value	
Usage:	If explicit authentication is being used, a valid client ID must be provided. If the value for client_id is 0, proxy access is used. Client_id is obtained by calling the acms \$mgmt_get_creds procedure.	
	<b>error_code</b>	
Type:	Integer	
Access:	Read	
Mechanism:	By value	
Usage:	The type of ACMS entity the process is.	

**cl2**

Type:	CLIENT *
Access:	Read
Mechanism:	By value
Usage:	Pointer to an RPC client handle previously obtained by calling the RPC routine CLNT_CREATE.

**Return Value**

Type:	Integer
Access:	Write
Mechanism:	By reference
Usage:	Pointer to a status code containing a success or failure status code. MGMT_SUCCESS indicates success. Other values indicate failure.

**Description**

This procedure deletes rows from the Error Filter table.

The Error Filter table is dynamic and does not have a fixed upper boundary. The size of the table fluctuates as entries are added and deleted. When a row becomes empty or unoccupied, it is removed and the remaining rows are renumbered.

Changes to the Error Filter table are processed immediately, and may affect more than one ACMS process.

## Example

```
int delete_err_filter(int client_id,CLIENT *cl2)
{
    int *status;
    err_filter_config_rec_r_2 set_struct;

    set_struct.client_id      = client_id;
    set_struct.err_code       = 16638720;

    status = acmsmgmt_delete_err_filter_2(&set_struct,cl2);

    if (!status) {
        printf("\n RPC Call to delete filter failed");
        return(MGMT_FAIL);
    }

    if (*status != MGMT_SUCCESS) {
        printf("\n Call to delete error filter failed with status
%d",*status);
        free(status);
        return(MGMT_FAIL);
    }
    else {
        printf("\n Call to delete error filter was executed");
    }
    free(status);
    return(0);
}
```

In the preceding example, the `acmsmgmt_delete_err_filter_2` procedure is called to delete a row from the Error Filter table.

## ACMSMGMT\_DELETE\_TRAP\_1

`ACMSMGMT_DELETE_TRAP_1` — This procedure deletes entries from the Remote Manager Trap table. Trap table entries can also be added and updated.

### Format

```
int *acmsmgmt_delete_trap_1(trap_del_rec *set_struct,CLIENT *cl)
```

### Parameters

#### set\_struct

Type:	Trap_del_rec
Access:	Read
Mechanism:	By reference
Usage:	Structure that contains the following client identification and Trap table fields.

<b>client_id</b>	
Type:	Integer
Access:	Read
Mechanism:	By value
Usage:	If explicit authentication is being used, a valid client ID must be provided. If the value for client_id is 0, proxy access is used. Client_id is obtained by calling the acms \$mgmt_get_creds procedure.
<b>entity_type</b>	
Type:	Integer
Access:	Read
Mechanism:	By value
Usage:	The type of ACMS entity the process is.
<b>entity_name</b>	
Type:	Null-terminated string
Access:	Read
Mechanism:	By reference
Usage:	Pointer to a character string containing a full or partial entity name. May contain wildcard characters (*, !).
<b>param_to_trap</b>	
Type:	Integer
Access:	Read
Mechanism:	By value
Usage:	The type of parameter to be monitored for trap conditions.

**cl**

Type:	CLIENT *
Access:	Read
Mechanism:	By value
Usage:	Pointer to an RPC client handle previously obtained by calling the RPC routine CLNT_CREATE.

**Return Value**

Type:	Integer
-------	---------

Access:	Write
Mechanism:	By reference
Usage:	Pointer to a status code containing a success or failure status code. MGMT_SUCCESS indicates success. Other values indicate failure.

## Description

This procedure deletes rows from the Trap table.

Calls to this procedure must specify `entity_type`, `entity_name`, and `param_to_trap`. These fields must exactly match an existing record in the Trap table for the delete to be performed. Table 8-1 and table 8-4 contain symbolic values used to populate the `collection_class` and `entity_type` fields; symbolic values to the `param_to_trap` field are described in Table 8-8.

Deletions from the Trap table are processed immediately and may affect more than one ACMS process.

## Example

```
int delete_trap_data(int client_id, CLIENT *cl)
{
    static char c_name_all[2] = "*";
    static trap_del_rec set_struct;
    static int *status;

    set_struct.client_id      = client_id
    set_struct.entity_type    = MGMT_ACC;
    set_struct.entity_name    = c_name_all;
    set_struct.param_to_trap  = MGMT_EXISTS;

    status = acmsgmt_delete_trap_1(&set_struct, cl);

    if (!status) {
        printf("\n Call to delete trap failed");
        return(MGMT_FAIL);
    }

    if (*status != MGMT_SUCCESS) {
        printf("\nCall to delete trap failed with status %d", *status);
        free(status);
        return(MGMT_FAIL);
    }
    else
        printf("\nCall to delete trap was executed");
        free(status);
        return(0);
}
```

In the preceding example, the `ACMSMGMT_DELETE_TRAP_1` procedure is called to delete a row from the Trap table. The row to be deleted contains an entity type of `ACC`, an entity name of `*` (all), and a trap parameter of `EXISTS`. If the call succeeds, the trap is deleted from the Trap table. Otherwise, an error message is displayed.

## ACMSMGMT\_GET\_ACC\_2

ACMSMGMT\_GET\_ACC\_2 — ACMS Remote Manager clients call this procedure to obtain class information about an ACMS Central Controller (ACC) on a local or remote node.

### Format

acc\_rec\_out\_2 \*acmsmgmt\_get\_acc\_2 (sub\_id\_struct \*sub\_rec, CLIENT \*cl)

### Parameters

#### sub\_rec

Type:	Sub_id_struct	
Access:	Read	
Mechanism:	By reference	
Usage:	Structure that contains the following client authorization information.	
	<b>client_id</b>	
	Type:	Integer
	Access:	Read
	Mechanism:	By value
Usage:	If explicit authentication is being used, a valid client ID must be provided. If the value for client_id is 0, proxy access is used. Client_id is obtained by calling the acms \$mgmt_get_creds procedure.	

#### cl

Type:	CLIENT *
Access:	Read
Mechanism:	By value
Usage:	Pointer to an RPC client handle previously obtained by calling the RPC routine CLNT_CREATE.

### Return Value

Type:	Acc_rec_out_2
Access:	Write
Mechanism:	By reference
Usage:	Pointer to record returned. If NULL, the RPC has failed. If not null, the record contains either an error code in the status field (the RPC succeeded, but the call failed for another reason) or the data requested.



## Description

This procedure obtains class information about an ACC. The return pointer points to a record of type `acc_rec_out_2`, which contains a union consisting of either a failure return code or a pointer to an ACC record.

If the ACMS run-time system is not running when this call is issued, the Remote Manager returns the `MGMT_NOT_MAPPED` error code.

## Example

```
int get_acc_data(int client_id, CLIENT *cl)
{
    acc_rec_r_2      *accs;
    acc_rec_out_2    *acc_rec;
    static struct sub_id_struct sub_rec;
    int status;

    sub_rec.client_id = client_id;

    acc_rec = acmsgmt_get_acc_2(&sub_rec, cl);

    if (!acc_rec) {
        printf("\n RPC Call to get ACC data failed");
        return(MGMT_FAIL);
    }

    if (acc_rec->status != MGMT_SUCCESS) {
        printf("\n Call to get ACC data failed, returning status code %d",
            acc_rec->status);
        xdr_free(xdr_acc_rec_out_2, acc_rec);
        free(acc_rec);
        return(status);
    }

    accs = &acc_rec->acc_rec_out_2_u.acc_rec;

    printf("\n ACC version is %s", accs->acms_version);
    xdr_free(xdr_acc_rec_out_2, acc_rec);
    free(acc_rec);
    return(0);
}
```

In the preceding example, the `ACMSMGMT_GET_ACC_2` procedure is called to fetch ACC management information. If the call succeeds, the ACC version is printed from the retrieved record. Otherwise, an error message is displayed.

## ACMS\$MGMT\_GET\_CREDS

`ACMS$MGMT_GET_CREDS` — Clients that support explicit authentication call this procedure to obtain a client ID. A client ID is issued for the client process when the client process logs in to the ACMS Remote Manager using the `ACMSMGR LOGIN` command. Once obtained by this procedure, the client ID is used on subsequent RPC calls.

## Format

```
int acms$mgmt_get_creds(char *server_node,char *user_name, int *client)
```

## Parameters

### server\_node

Type:	String
Access:	Read
Mechanism:	By reference
Usage:	Name of the node the server that issued the client ID was running on; the node that will be accessed. Client_id is valid only for the server that issued it.

### user\_name

Type:	String
Access:	Read
Mechanism:	By reference
Usage:	Name of the user the client ID was issued to, and on whose behalf the client ID is used. The name may be the same as or different than the account name of the client process.

### client

Type:	Integer
Access:	Write
Mechanism:	By reference
Usage:	The client ID to be used for the target user on the target server node. The client ID is valid only for the client process that created it.

## Return Value

Type:	Integer								
Access:	Write								
Mechanism:	By value								
Usage:	The completion status of the call. The following are possible return values:								
	<table border="1"> <thead> <tr> <th>Value</th> <th>Description</th> </tr> </thead> <tbody> <tr> <td>MGMT_SUCCESS</td> <td>Client ID was fetched; credentials verified.</td> </tr> <tr> <td>MGMT_NO_NODELOGICAL</td> <td>Can't translate UCX \$INET_HOST logical name to get local node name.</td> </tr> <tr> <td>MGMT_NO_CREDS_FILE</td> <td>Credentials file was not found.</td> </tr> </tbody> </table>	Value	Description	MGMT_SUCCESS	Client ID was fetched; credentials verified.	MGMT_NO_NODELOGICAL	Can't translate UCX \$INET_HOST logical name to get local node name.	MGMT_NO_CREDS_FILE	Credentials file was not found.
Value	Description								
MGMT_SUCCESS	Client ID was fetched; credentials verified.								
MGMT_NO_NODELOGICAL	Can't translate UCX \$INET_HOST logical name to get local node name.								
MGMT_NO_CREDS_FILE	Credentials file was not found.								

	MGMT_CREDS_DATA_ERR	Credentials file is corrupt.
	MGMT_WRONG_PID	PID in credentials file doesn't match client process's PID.
	MGMT_WRONG_NODE	Node name in credentials file doesn't match server_node argument.

## Description

Clients call this procedure to fetch a previously created client ID from an encrypted credentials file. Credentials files can be created only by the ACMSMGR LOGIN command. They are stored in the directory pointed to by the logical name ACMS\$MGMT\_CREDS\_DIR (or SYS\$LOGIN if ACMS\$MGMT\_CREDS\_DIR is not defined). Credentials files are named using the following format:

```
user-name_pid_target-node_current-node.dat
```

In this format:

- *user-name* must match the user\_name argument string.
- *pid* must match the PID of the client process.
- *target-node* must match the server\_node argument string.
- *current-node* must be the local node name (as determined by the logical name UCX \$INET\_HOST).

---

## Note

For credentials information to be created, the client process must first execute the login command of the ACMSMGR utility. The only way to create credentials files is by using the ACMSMGR utility.

If the credentials file cannot be located, opened, and read, an error is returned. Once opened and read, the credentials in the file are verified. If the credentials are acceptable, the client\_id field is populated and the procedure returns a status that indicates success.

This procedure is statically linked and locally executed.

## Example

```
#include <rpc/rpc.h>
#include string
#include "acmsmgmt_rpc.h"

CLIENT *cl;
char sname[] = "sparks";
char *username_p, username[13] = "";
int client_id;
int status;

int acms$mgmt_get_creds();

int main ()
{
```

```

/* if the logical is defined, credential information will be used */
username_p = getenv("ACMS$MGMT_USER");
if (username_p)
    strcpy(username,username_p);

/* establish an rpc connection to the server */
cl = clnt_create(sname, ACMSMGMT_RPC, ACMSMGMT_VERSION, "tcp");

/* if the connection was established */
if (cl != NULL) {

    /* create a security context */
    cl->cl_auth = authunix_create_default();
    client_id = 0;

    /* optionally, get credentials for this user & server */
    if (strlen(username))
        status = acms$mgmt_get_creds(sname,username,&client_id);

}

return(1);
}

```

The preceding example is a program that performs initialization for an ACMS Remote Manager client. The program calls the `acms$mgmt_get_creds` procedure to obtain the client ID for the user whose name is defined by the logical name `ACMS$MGMT_USER` on the node `SPARKS`.

## ACMSMGMT\_GET\_ERR\_FILTER\_2

`ACMSMGMT_GET_ERR_FILTER_2` — ACMS Remote Manager clients call this procedure to obtain a listing of system messages currently being filtered from the Remote Manager, and subsequently, the error log.

### Format

```
int *acmsmgmt_get_err_filter_2 (sub_id_struct *sub_id_rec,CLIENT *cl2)
```

### Parameters

#### sub\_id\_rec

Type:	Sub_id_struct	
Access:	Read	
Mechanism:	By reference	
Usage:	Structure that contains the following client authorization information.	
	<b>client_id</b>	
	Type:	Integer
	Access:	Read
	Mechanism:	By value

	Usage:	If explicit authentication is being used, a valid client ID must be provided. If the value for <code>client_id</code> is 0, proxy access is used. <code>Client_id</code> is obtained by calling the <code>acms \$mgmt_get_creds</code> procedure.
--	--------	---

**cl2**

Type:	CLIENT *
Access:	Read
Mechanism:	By value
Usage:	Pointer to an RPC client handle previously obtained by calling the RPC routine <code>CLNT_CREATE</code> .

**Return Value**

Type:	Err_filter_data_list_2
Access:	Write
Mechanism:	By reference
Usage:	Pointer to record returned. If NULL, the RPC has failed. If not null, the record contains either an error code in the status field (the RPC succeeded, but the call failed for another reason) or the data requested.

**Description**

This procedure obtains class information about an Error Filter. The return pointer points to a record of type `err_filter_data_list_2`, which is a union containing either an error code or a pointer to an Error Filter record.

If the ACMS run-time system is not running when this call is issued, the Remote Manager returns the `MGMT_NOT_MAPPED` error code.

**Example**

```
int get_err_filter(int client_id, CLIENT *cl2)
{
    int status;
    err_filter_data_list_2    *err_filter;
    err_filter_link_2        *nl;
    struct sub_id_struct sub_rec;

    sub_rec.client_id = client_id;

    err_filter = acmsmgmt_get_err_filter_2(&sub_rec, cl2);

    if (!err_filter) {
```

```

        printf("\n RPC Call to get Error Filter failed");
        return(MGMT_FAIL);
    }

    if (err_filter->status != MGMT_SUCCESS) {
        printf("\n Call to get Error Filter failed, returning status code
%d",
            err_filter->status);
        status = err_filter->status;
        xdr_free(xdr_err_filter_data_list_2, err_filter);
        free(err_filter);
        return(status);
    }

    for (nl = err_filter->err_filter_data_list_2_u.list; nl != NULL;
        nl = nl->pNext) {
        printf("Filter name = %s, and code =%X\n",
            nl->err_filter_data.err_msg_name,
            nl->err_filter_data.err_code);
    }

    xdr_free(xdr_err_filter_data_list_2, err_filter);
    free(err_filter);
    return(0);
}

```

In the preceding example, the `acmsmgmt_get_err_filter_2` procedure is called to fetch error filter information. If the call succeeds, the message code and symbolic name are fetched. Otherwise, an error message is displayed.

## ACMSMGMT\_GET\_MGR\_STATUS\_1

`ACMSMGMT_GET_MGR_STATUS_1` — ACMS Remote Manager clients call this procedure to obtain run-time status information about a Remote Manager on a particular node.

### Format

`mgr_status_rec_out *acmsmgmt_get_mgr_status_1(sub_id_struct *sub_rec, CLIENT *cl)`

### Parameters

#### `sub_rec`

Type:	Sub_id_struct	
Access:	Read	
Mechanism:	By reference	
Usage:	Structure that contains the following client authorization information.	
	<b>client_id</b>	
	Type:	Integer
	Access:	Read

	Mechanism:	By value
	Usage:	If explicit authentication is being used, a valid client ID must be provided. If the value for client_id is 0, proxy access is used. Client_id is obtained by calling the acms \$mgmt_get_creds procedure.

**cl**

Type:	CLIENT *
Access:	Read
Mechanism:	By value
Usage:	Pointer to an RPC client handle previously obtained by calling the RPC routine CLNT_CREATE.

**Return Value**

Type:	Mgr_status_rec_out
Access:	Write
Mechanism:	By reference
Usage:	Pointer to a record that contains a union consisting either of a failure code or a pointer to a structure of type mgr_status_rec, which contains the status data. The following are the contents of this union:
<b>rc</b>	
Type:	Integer
Access:	Write
Mechanism:	By value
Usage:	Failure return code.
<b>data</b>	
Type:	Mgr_status_rec
Access:	Write
Mechanism:	By reference
Usage:	Remote Manager status data record. Contains the fields from the Manager Status table.

**Description**

This procedure gets run-time information about a Remote Manager on a particular node. The return pointer points to a record of type mgr\_status\_rec\_out, which contains a union consisting of a failure returns code or a pointer to a manager status record.

This procedure does not require the ACMS run-time system in order to execute.

## Example

```

int get_mgr_data(int client_id, CLIENT *cl)
{
    mgr_status_rec          *mgrs;
    mgr_status_rec_out      *mgr_data;
    static struct sub_id_struct sub_rec;
    int status;

    sub_rec.client_id = client_id;

    mgr_data = acmsmgmt_get_mgr_status_1(&sub_rec, cl);

    if (!mgr_data) {
        printf("\n RPC Call to get RM data failed");
        return(MGMT_FAIL);
    }

    if (mgr_data->status != MGMT_SUCCESS) {
        printf("\n Call to get RM data failed, returning status code %d",
            mgr_data->status);
        status = mgr_data->status;
        xdr_free(xdr_mgr_status_rec_out, mgr_data);
        free(mgr_data);
        return(status);
    }

    mgrs = &mgr_data->mgr_status_rec_out_u.data;

    printf("\n RPC UDP state is %d", mgrs->rpc_udp_state);
    xdr_free(xdr_mgr_status_rec_out, mgr_data);
    free(mgr_data);
    return(0);
}

```

In the preceding example, the `ACMSMGMT_GET_MGR_STATUS_1` procedure is called to fetch the contents of the Manager Status table. If the call succeeds, the current state of the TCP/UDP protocol in the RPC interface is printed from the retrieved record. Otherwise, an error message is displayed.

## ACMSMGMT\_GET\_PARAM\_2

`ACMSMGMT_GET_PARAM_2` — ACMS Remote Manager clients call this procedure to obtain configuration information about a Remote Manager on a particular node.

### Format

```
param_rec_out2 *acmsmgmt_get_param_2(sub_id_struct *sub_rec, CLIENT *cl)
```

### Parameters

#### sub\_rec

Type:	Sub_id_struct
Access:	Read



Mechanism:	By reference	
Usage:	Structure that contains the following client authorization information.	
	<b>client_id</b>	
	Type:	Integer
	Access:	Read
	Mechanism:	By value
	Usage:	If explicit authentication is being used, a valid client ID must be provided. If the value for client_id is 0, proxy access is used. Client_id is obtained by calling the acms \$mgmt_get_creds procedure.

**cl**

Type:	CLIENT *
Access:	Read
Mechanism:	By value
Usage:	Pointer to an RPC client handle previously obtained by calling the RPC routine CLNT_CREATE.

**Return Value**

Type:	Param_rec_out2
Access:	Write
Mechanism:	By reference
Usage:	Pointer to record returned. If NULL, the RPC has failed. If not null, the record contains either an error code in the status field (the RPC succeeded, but the call failed for another reason), or the data requested.

**Description**

This procedure gets configuration information about a Remote Manager on a particular node. The return pointer points to a record of type param\_rec\_out2, which contains a union consisting of either a failure return code or a pointer to a Parameter record.

This procedure does not require the ACMS run-time system in order to execute.

**Example**

```
int get_param_data(int client_id, CLIENT *cl)
{
    int x = 0;
    int y = 0;
```

```

param_rec2      *params;
param_rec_out2  *param_rec;
static struct sub_id_struct sub_rec;
int status;

sub_rec.client_id = client_id;

param_rec = acmsmgmt_get_param_2(&sub_rec,cl);

if (!param_rec) {
    printf("\n RPC Call to get Parameter data failed");
    return(MGMT_FAIL);
}

if (param_rec->status != MGMT_SUCCESS) {
    printf("\n Call to get Parameter data failed, returning status code
%d",
        param_rec->status);
    status = param_rec->status;
    xdr_free(xdr_param_rec_out2, param_rec);
    free(param_rec);
    return(status);
}

params = &param_rec->param_rec_out2_u.data;

printf("\n Maximum logins allowed is %d",params->max_logins);
xdr_free(xdr_param_rec_out2, param_rec);
free(param_rec);
return(0);
}

```

In the preceding example, the `ACMSMGMT_GET_PARAM_2` procedure is called to fetch the contents of the Parameter table. If the call succeeds, the maximum number of logins is printed from the retrieved record. Otherwise, an error message is displayed.

## ACMSMGMT\_GET\_QTI\_2

`ACMSMGMT_GET_QTI_2` — ACMS Remote Manager clients call this procedure to obtain class information about a Queued Task Initiator (QTI) on a local or remote node.

### Format

`qti_rec_out_2 *acmsmgmt_get_qti_2(sub_id_struct *sub_rec, CLIENT *cl)`

### Parameters

#### sub\_rec

Type:	Sub_id_struct
Access:	Read
Mechanism:	By reference
Usage:	Structure that contains the following client authorization information.

	<b>client_id</b>	
Type:		Integer
Access:		Read
Mechanism:		By value
Usage:		If explicit authentication is being used, a valid client ID must be provided. If the value for client_id is 0, proxy access is used. Client_id is obtained by calling the acms \$mgmt_get_creds procedure.

**cl**

Type:	CLIENT *
Access:	Read
Mechanism:	By value
Usage:	Pointer to an RPC client handle previously obtained by calling the RPC routine CLNT_CREATE.

**Return Value**

Type:	Qti_rec_out2
Access:	Write
Mechanism:	By reference
Usage:	Pointer to record returned. If NULL, the RPC has failed. If not null, the record contains either an error code in the status field (the RPC succeeded, but the call failed for another reason) or the data requested.

**Description**

This procedure obtains class information about a QTI on a local or remote node. The return pointer points to a record of type qti\_rec\_out\_2, which contains a union consisting of either a failure return code or a pointer to a QTI record.

If the ACMS run-time system is not running when this call is issued, the Remote Manager returns the MGMT\_NOT\_MAPPED error code.

**Example**

```
int get_qti_data(int client_id, CLIENT *cl)
{
    qti_rec_r_2      *qtis;
    qti_rec_out_2    *qti_rec;
    static struct sub_id_struct sub_rec;
    int status;

    sub_rec.client_id = client_id;
```

```

qti_rec = acmsmgmt_get_qti_2(&sub_rec,cl);

if (!qti_rec) {
    printf("\n RPC Call to get QTI data failed");
    return(MGMT_FAIL);
}

if (qti_rec->status != MGMT_SUCCESS) {
    printf("\n Call to get QTI data failed, returning status code %d",
        qti_rec->status);
    status = qti_rec->status;
    xdr_free(xdr_qti_rec_out_2, qti_rec);
    free(qti_rec);
    return(status);
}

qtis = &qti_rec->qti_rec_out_2_u.qti_rec;

printf("\n QTI process name is %s",qtis->process_name);
xdr_free(xdr_qti_rec_out_2, qti_rec);
free(qti_rec);
return(0);
}

```

In the preceding example, the `ACMSMGMT_GET_QTI_2` procedure is called to fetch QTI management information. If the call succeeds, the QTI process name is printed from the retrieved record. Otherwise, an error message is displayed.

## ACMSMGMT\_GET\_TSC\_2

`ACMSMGMT_GET_TSC_2` — ACMS Remote Manager clients call this procedure to obtain class information about a Terminal Subsystem Controller (TSC) on a local or remote node.

### Format

`tsc_rec_out_2 *acmsmgmt_get_tsc_2(sub_id_struct *sub_rec, CLIENT *cl)`

### Parameters

#### `sub_rec`

Type:	Sub_id_struct	
Access:	Read	
Mechanism:	By reference	
Usage:	Structure that contains the following client authorization information.	
	<b>client_id</b>	
	Type:	Integer
	Access:	Read
	Mechanism:	By value

	Usage:	If explicit authentication is being used, a valid client ID must be provided. If the value for <code>client_id</code> is 0, proxy access is used. <code>Client_id</code> is obtained by calling the <code>acms \$mgmt_get_creds</code> procedure.
--	--------	---

**cl**

Type:	CLIENT *
Access:	Read
Mechanism:	By value
Usage:	Pointer to an RPC client handle previously obtained by calling the RPC routine <code>CLNT_CREATE</code> .

**Return Value**

Type:	Tsc_rec_out_2
Access:	Write
Mechanism:	By reference
Usage:	Pointer to record returned. If NULL, the RPC has failed. If not null, the record contains either an error code in the status field (the RPC succeeded, but the call failed for another reason) or the data requested.

**Description**

The return pointer points to a record of type `tsc_rec_out_2`, which contains a union consisting of either a failure return code or a pointer to a TSC record.

If the ACMS run-time system is not running when this call is issued, the Remote Manager returns the `MGMT_NOT_MAPPED` error code.

**Example**

```
int get_tsc_data(int client_id, CLIENT *cl)
{
    tsc_rec_r_2      *tscs;
    tsc_rec_out_2    *tsc_rec;
    static struct sub_id_struct sub_rec;
    int status;

    sub_rec.client_id = client_id;

    tsc_rec = acmsmgmt_get_tsc_2(&sub_rec, cl);

    if (!tsc_rec) {
        printf("\n RPC Call to get TSC data failed");
        return(MGMT_FAIL);
    }
}
```

```

if (tsc_rec->status != MGMT_SUCCESS) {
    printf("\n Call to get TSC data failed, returning status code %d",
        tsc_rec->status);
    status = tsc_rec->status;
    xdr_free(xdr_tsc_rec_out_2, tsc_rec);
    free(tsc_rec);
    return(status);
}

tscs = &tsc_rec->tsc_rec_out_2_u.tsc_rec;

printf("\n TSC process name is %s",tscs->process_name);
xdr_free(xdr_tsc_rec_out_2, tsc_rec);
free(tsc_rec);
return(0);
}

```

In the preceding example, the `ACMSMGMT_GET_TSC_2` procedure is called to fetch TSC management information. If the call succeeds, the TSC's process name is printed from the retrieved record. Otherwise, an error message is displayed.

## ACMSMGMT\_GET\_VERSION\_2

`ACMSMGMT_GET_VERSION_2` — ACMS Remote Manager clients call this procedure to obtain version information for ACMS.

### Format

`version_data_list_2 *acmsmgmt_get_version_2(sub_id_struct *sub_rec, CLIENT *cl)`

### Parameters

#### sub\_rec

Type:	Sub_id_struct	
Access:	Read	
Mechanism:	By reference	
Usage:	Structure that contains the following client authorization information.	
	<b>client_id</b>	
	Type:	Integer
	Access:	Read
	Mechanism:	By value
Usage:	If explicit authentication is being used, a valid client ID must be provided. If the value for <code>client_id</code> is 0, proxy access is used. <code>Client_id</code> is obtained by calling the <code>acms \$mgmt_get_creds</code> procedure.	

**cl**

Type:	CLIENT *
Access:	Read
Mechanism:	By value
Usage:	Pointer to an RPC client handle previously obtained by calling the RPC routine CLNT_CREATE.

**Return Value**

Type:	version_data_list_2
Access:	Write
Mechanism:	By reference
Usage:	Pointer to record returned. If NULL, the RPC has failed. If not null, the record contains either an error code in the status field (the RPC succeeded, but the call failed for another reason) or the data requested.

**Description**

The return pointer points to a record of type `version_data_list_2`, which contains a union consisting of either a failure return code or a pointer to a version record.

If the ACMS run-time system is not running when this call is issued, the Remote Manager returns the `MGMT_NOT_MAPPED` error code.

**Example**

```
int get_version_data(int client_id, CLIENT *cl2)
{
    struct sub_id_struct sub_rec;
    version_data_list_2 *version;
    int status;

    sub_rec.client_id = client_id;

    version = acmsmgmt_get_version_2(&sub_rec, cl2);

    if (!version) {
        printf("\n RPC Call to get Version data failed");
        return(MGMT_FAIL);
    }

    if (version->status != MGMT_SUCCESS) {
        printf("\n Call to get Version data failed, returning status code
%d",
            version->status);
        status = version->status;
        xdr_free(xdr_version_data_list_2, version);
        free(version);
        return(status);
    }
}
```

```

}

printf("\n ACMS version is %s",version->
    version_data_list_2_u.data.acms_version);
xdr_free(xdr_version_data_list_2, version);
free(version);
return(0);
}

```

In the preceding example, the `ACMSMGMT_GET_VERSION_2` procedure is called to fetch ACMS version information. If the call succeeds, the version of the installed ACMS software is printed from the retrieved record. Otherwise, an error message is displayed.

## ACMSMGMT\_LIST\_COLLECTIONS\_2

`ACMSMGMT_LIST_COLLECTIONS_2` — ACMS Remote Manager clients call this procedure to obtain a list of Collection table entries.

### Format

`coll_data_list_2 *acmsmgmt_list_collections_2(coll_sel_struct *coll_rec, CLIENT *cl)`

### Parameters

#### `coll_rec`

Type:	Coll_sel_struct	
Access:	Read	
Mechanism:	By reference	
Usage:	Defines starting point for list of records to be returned. Also identifies the user. The <code>coll_rec</code> structure contains the following fields:	
	<b>client_id</b>	
	Type:	Integer
	Access:	Read
	Mechanism:	By value
	Usage:	If explicit authentication is being used, a valid client ID must be provided. If the value for <code>client_id</code> is 0, proxy access is used.
	<b>starting_rec</b>	
	Type:	Integer
	Access:	Read
	Mechanism:	By value
	Usage:	Sequential record number (starting at 0) of record to begin list from. Records are returned



sequentially from the table. Up to `max_rpc_return_recs` (Parameter table configuration value) are returned in each call.

**cl**

Type:	CLIENT *
Access:	Read
Mechanism:	By value
Usage:	Pointer to an RPC client handle previously obtained by calling the RPC routine <code>CLNT_CREATE</code> .

**Return Value**

Type:	Coll_data_list_2	
Access:	Write	
Mechanism:	By reference	
Usage:	<p>Pointer to a union. The union contains either a failure code or a pointer to a structure of type <code>coll_list</code>, which contains the start of a linked list of records. The following are the contents of this union:</p>	
	<b>rc</b>	
	Type:	Integer
	Access:	Write
	Mechanism:	By value
	Usage:	Failure return code.
	<b>list</b>	
	Type:	Coll_list_2
	Access:	Write
	Mechanism:	By reference
	Usage:	Start of linked list. Pointer to a structure of collection table record, and a forward pointer to the next node in the linked list. The following are the contents of this structure:
	<b>pNext</b>	
	Type:	Coll_list_2
	Access:	Write
	Mechanism:	By value
	Usage:	Start of linked list. Pointer to a structure of type <code>coll_list</code> .
	<b>coll_data</b>	
	Type:	Coll_rec_2
	Access:	Write
	Mechanism:	By reference

		Usage:	Collection table row. Collection table fields are described in Section 9.4.
--	--	--------	---

## Description

The `ACMSMGMT_LIST_COLLECTIONS_2` procedure returns a linked list of collection table rows. The number of rows returned in a single call is bounded by the value of the Parameter table field `max_rpc_return_recs`. More than one call may be required to fetch all the rows. The selection record field `starting_rec` determines the table row to begin with. Records are returned sequentially from the table, beginning with the `starting_rec` row. Row numbering begins at 0.

Entire table rows are returned. See Section 9.4 for a description of the fields in the `coll_rec` structure.

If the ACMS run-time system is not running when this call is issued, the Remote Manager returns the `MGMT_NOT_MAPPED` error code.

If the end of the table is reached during execution of this procedure, `MGMT_NOMORE_DATA` is returned in the status field.

## Example

```
int list_collection_data(int client_id, CLIENT *cl)
{
    int rec_count = 0;
    coll_data_list_2 *coll;
    coll_link_2 *nl;
    static struct coll_sel_struct coll_rec;
    int status;
    char c_states[2][9] = {"enabled", "disabled"};
    char c_entities[10][9] = {"unknown", "*", "acc", "tsc", "qti", "cp", "exc",
                             "server", "group", "mgr"};
    char c_classes[6][8] = {"*", "id", "config", "runtime", "pool", "error"};

    coll_rec.client_id = client_id;
top:
    coll_rec.starting_rec = rec_count;

    coll = acmsgmt_list_collections_2(&coll_rec, cl);

    if (!coll) {
        printf("\n RPC Call to get Collection data failed");
        return(MGMT_FAIL);
    }

    if ((coll->status != MGMT_SUCCESS) && (coll->status !=
MGMT_NOMORE_DATA)) {
        printf("\n Call to get Collection data failed, returning status code
            %d", coll->status);
        xdr_free(xdr_coll_data_list2, coll);
        free(coll);
        return(status);
    }

    for (nl = coll->coll_data_list_2_u.list; nl != NULL; nl = nl->pNext) {
        rec_count++;
        if (nl->coll_data.entity_name_s > 0)

```

```

    printf("\n Entity: %-9s  Name: %-32s  Class: %-9s
           Collection State: %-9s",
           c_entities[nl->coll_data.entity_type],
           nl->coll_data.entity_name,
           c_classes[nl->coll_data.collection_class],
           c_states[nl->coll_data.collection_state]);
}

if (coll->status != MGMT_NOMORE_DATA)
    goto top;

printf("\n End of data");
xdr_free(xdr_coll_data_list_2, coll);
free(coll);
return(0);
}

```

In the preceding example, the `ACMSMGMT_LIST_COLLECTIONS_2` procedure is called to fetch the contents of the Collection table. If the call succeeds, the entity type, name, class, and collection state are printed for each row in the table. Otherwise, an error message is displayed.

## ACMSMGMT\_LIST\_CP\_2

`ACMSMGMT_LIST_CP_2` — ACMS Remote Manager clients call this procedure to obtain a list of Command Process (CP) table entries.

### Format

`cp_data_list_2 *acmsmgmt_list_cp_2(cp_sel_struct *sub_rec, CLIENT *cl)`

### Parameters

#### sub\_rec

Type:	Cp_sel_struct	
Access:	Read	
Mechanism:	By reference	
Usage:	Structure that contains the following client authorization information.	
	<b>client_id</b>	
	Type:	Integer
	Access:	Read
	Mechanism:	By value
	Usage:	If explicit authentication is being used, a valid client ID must be provided. If the value for <code>client_id</code> is 0, proxy access is used. <code>Client_id</code> is obtained by calling the <code>acms \$mgmt_get_creds</code> procedure.
	<b>proc_name</b>	

Type:	String
Access:	Read
Mechanism:	By value
Usage:	String that lists the OpenVMS process name for each CP.

**cl**

Type:	CLIENT *
Access:	Read
Mechanism:	By value
Usage:	Pointer to an RPC client handle previously obtained by calling the RPC routine CLNT_CREATE.

**Return Value**

Type:	Cp_data_list_2																														
Access:	Write																														
Mechanism:	By reference																														
Usage:	<p>Pointer to a record that contains a union consisting of either a failure code or a pointer to a structure of type cp_data_list2, which contains the start of a linked list of records. The following are the contents of this union:</p> <p><b>rc</b></p> <table border="1"> <tr> <td>Type:</td> <td>Integer</td> </tr> <tr> <td>Access:</td> <td>Write</td> </tr> <tr> <td>Mechanism:</td> <td>By value</td> </tr> <tr> <td>Usage:</td> <td>Failure return code.</td> </tr> </table> <p><b>list</b></p> <table border="1"> <tr> <td>Type:</td> <td>Cp_list_2</td> </tr> <tr> <td>Access:</td> <td>Write</td> </tr> <tr> <td>Mechanism:</td> <td>By reference</td> </tr> <tr> <td>Usage:</td> <td>Start of linked list. Pointer to a structure of CP table record, and a forward pointer to the next node in the linked list. The following are the contents of this structure:</td> </tr> <tr> <td colspan="2"><b>pNext</b></td> </tr> <tr> <td>Type:</td> <td>Cp_list_2</td> </tr> <tr> <td>Access:</td> <td>Write</td> </tr> <tr> <td>Mechanism:</td> <td>By value</td> </tr> <tr> <td>Usage:</td> <td>Start of linked list. Pointer to a structure of type coll_list.</td> </tr> <tr> <td colspan="2"><b>cp_data</b></td> </tr> <tr> <td>Type:</td> <td>Cp_rec_r_2</td> </tr> </table>	Type:	Integer	Access:	Write	Mechanism:	By value	Usage:	Failure return code.	Type:	Cp_list_2	Access:	Write	Mechanism:	By reference	Usage:	Start of linked list. Pointer to a structure of CP table record, and a forward pointer to the next node in the linked list. The following are the contents of this structure:	<b>pNext</b>		Type:	Cp_list_2	Access:	Write	Mechanism:	By value	Usage:	Start of linked list. Pointer to a structure of type coll_list.	<b>cp_data</b>		Type:	Cp_rec_r_2
Type:	Integer																														
Access:	Write																														
Mechanism:	By value																														
Usage:	Failure return code.																														
Type:	Cp_list_2																														
Access:	Write																														
Mechanism:	By reference																														
Usage:	Start of linked list. Pointer to a structure of CP table record, and a forward pointer to the next node in the linked list. The following are the contents of this structure:																														
<b>pNext</b>																															
Type:	Cp_list_2																														
Access:	Write																														
Mechanism:	By value																														
Usage:	Start of linked list. Pointer to a structure of type coll_list.																														
<b>cp_data</b>																															
Type:	Cp_rec_r_2																														

		Access:	Write
		Mechanism:	By reference
		Usage:	CP table row. CP table fields are described in Section 9.5.

## Description

The `ACMSMGMT_LIST_CP_2` procedure returns a linked list of CP table rows. All CP table rows are returned in each call. Records are returned sequentially from the table, beginning at the start of the table.

Entire table rows are returned. See Section 9.5 for a description of the fields in the `cp_rec_r` structure.

If the ACMS run-time system is not running when this call is issued, the Remote Manager returns the `MGMT_NOT_MAPPED` error code.

Rows in the CP table are subject to reuse. Rows are assigned round-robin, and are not cleared until they have been reassigned. So some rows may contain data for inactive CPs. It is the caller's responsibility to examine the `record_state` field to determine whether this row belongs to an active (`record_state` field is `MGMT_VALID`) or inactive (`record_state` field is `MGMT_INACTIVE`) CP, and to process the row accordingly.

## Example

```
int list_cp_data(int client_id, CLIENT *cl)
{
    static char c_all_cps[2] = "*";
    cp_data_list_2 *cp_data;
    cp_link_2 *nl;
    static struct cp_sel_struct sub_rec;
    int status;

    sub_rec.client_id = client_id;
    sub_rec.proc_name = c_all_cps;

    cp_data = acmsmgmt_list_cp_2(&sub_rec, cl);

    if (!cp_data) {
        printf("\n RPC Call to get CP data failed");
        return(MGMT_FAIL);
    }

    if (cp_data->status == MGMT_FAIL) {
        if (cp_data->cp_data_list_2_u.rc == MGMT_NOMORE_DATA) {
            printf("\n No CP data found");
            xdr_free(xdr_cp_data_list_2, cp_data);
            free(cp_data);
            return(MGMT_FAIL);
        }
        printf("\n Call to get CP data failed, returning status code %d",
            cp_data->cp_data_list_2_u.rc);
        status = cp_data->cp_data_list_2_u.rc;
        xdr_free(xdr_cp_data_list_2, cp_data);
        free(cp_data);
        return(status);
    }
}
```

```

if (cp_data->status == MGMT_WARN)
    printf("\n ** Warning, some data may be from inactive processes
**");

for (nl = cp_data->cp_data_list_2_u.list; nl != NULL; nl = nl->pNext) {
    if (nl->cp_data.record_state == MGMT_INACTIVE)
        printf("\n INACTIVE ");
    else
        printf("\n          ");
    printf(" PID: %8X  Process Name: %-s",
        nl->cp_data.pid,
        nl->cp_data.process_name);
}

printf("\n End of data");
xdr_free(xdr_cp_data_list_2, cp_data);
free(cp_data);
return(0);
}

```

In the preceding example, the `ACMSMGMT_LIST_CP_2` procedure is called to fetch the contents of the CP table. If the call succeeds, the state of the CP (if `INACTIVE`), its PID, and process name are displayed for each table row returned. Otherwise, an error message is displayed.

## ACMSMGMT\_LIST\_EXC\_2

`ACMSMGMT_LIST_EXC_2` — ACMS Remote Manager clients call this procedure to obtain a list of Application Execution Controller (EXC) (ACMS application) table entries.

### Format

`exc_data_list_2 *acmsmgmt_list_exc_2(exc_sel_struct *sub_rec, CLIENT *cl)`

### Parameters

#### `sub_rec`

Type:	Exc_sel_struct	
Access:	Read	
Mechanism:	By reference	
Usage:	Structure that contains client information and application selection criteria. The structure contains the following fields.	
	<b>client_id</b>	
	Type:	Integer
	Access:	Read
	Mechanism:	By value
	Usage:	If explicit authentication is being used, a valid client ID must be provided. If the value for <code>client_id</code> is 0, proxy access is used. <code>Client_id</code> is

		obtained by calling the acms \$mgmt_get_creds procedure.
	<b>appl_name</b>	
Type:		Null-terminated string
Access:		Read
Mechanism:		By reference
Usage:		A pointer to an application name. The name may contain wildcard characters (*, !). Specify in all uppercase characters.

**cl**

Type:	CLIENT *
Access:	Read
Mechanism:	By value
Usage:	Pointer to an RPC client handle previously obtained by calling the RPC routine CLNT_CREATE.

**Return Value**

Type:	Exc_data_list_2	
Access:	Write	
Mechanism:	By reference	
Usage:	Pointer to a record that contains a union consisting of either a failure code or a pointer to a structure of type exc_data_list_2, which contains the start of a linked list of records. The following are the contents of this union:	
	<b>rc</b>	
Type:	Integer	
Access:	Write	
Mechanism:	By value	
Usage:	Failure return code.	
	<b>list</b>	
Type:	Exc_list_2	
Access:	Write	
Mechanism:	By reference	
Usage:	Start of linked list. Pointer to a structure containing an EXC table record, and a forward pointer to the next node in the linked list. The following are the contents of this structure:	
	<b>pNext</b>	
Type:	Exc_list_2	
Access:	Write	

	Mechanism:	By value
	Usage:	Start of linked list. Pointer to a structure of type coll_list.
<b>exc_data</b>		
	Type:	Exc_rec_r_2
	Access:	Write
	Mechanism:	By reference
	Usage:	EXC table row. EXC table fields are described in Section 9.6.

## Description

The ACMSMGMT\_LIST\_EXC\_2 procedure returns a linked list of EXC table rows. All EXC table rows whose application\_name field matches the appl\_name field in the selection record are returned in each call.

Entire table rows are returned. See Section 9.6 for a description of the fields in the exc\_rec\_r structure.

If the ACMS run-time system is not running when this call is issued, the Remote Manager returns the MGMT\_NOT\_MAPPED error code.

Rows in the EXC table are subject to reuse. Rows are assigned round-robin, and are not cleared until they have been reassigned. Therefore, some rows may contain data for inactive EXCs. It is the caller's responsibility to examine the record\_state field to determine whether this row belongs to an active (record\_state field is MGMT\_VALID) or inactive (record\_state field is MGMT\_INACTIVE) EXC, and to process the row accordingly.

## Example

```
int list_exc_data(int client_id, CLIENT *cl)
{
    static char c_all_appls[2] = "*";
    exc_data_list_2 *exc_data;
    exc_link_2 *nl;
    static struct exc_sel_struct sub_rec;
    int status;

    sub_rec.client_id = client_id;
    sub_rec.appl_name = c_all_appls;

    exc_data = acmsgmt_list_exc_2(&sub_rec, cl);

    if (!exc_data) {
        printf("\n RPC Call to get EXC data failed");
        return(MGMT_FAIL);
    }

    if (exc_data->status == MGMT_FAIL) {
        if (exc_data->exc_data_list_2_u.rc == MGMT_NOMORE_DATA) {
            printf("\n No EXC data found");
            xdr_free(xdr_exc_data_list_2, exc_data);
        }
    }
}
```



```

        free(exc_data);
        return(MGMT_FAIL);
    }
    printf("\n Call to get EXC data failed, returning status code %d",
        exc_data->exc_data_list_2_u.rc);
    status = exc_data->exc_data_list_2_u.rc;
    xdr_free(xdr_exc_data_list_2, exc_data);
    free(exc_data);
    return(status);
}

if (exc_data->status == MGMT_WARN)
    printf("\n ** Warning, some data may be from inactive processes
**");

for (nl = exc_data->exc_data_list_2_u.list; nl != NULL; nl = nl->pNext)
{
    if (nl->exc_data.record_state == MGMT_INACTIVE)
        printf("\n INACTIVE ");
    else
        printf("\n          ");
    printf(" PID: %8X  Application : %-s",
        nl->exc_data.pid,
        nl->exc_data.appl_name);
}

printf("\n End of data");
xdr_free(xdr_exc_data_list_2, exc_data);
free(exc_data);
return(0);
}

```

In the preceding example, the `ACMSMGMT_LIST_EXC_2` procedure is called to fetch the contents of the EXC table. If the call succeeds, the state of the EXC (if inactive), its PID, and its application name are displayed for each table row returned. Otherwise, an error message is displayed.

## ACMSMGMT\_LIST\_INTERFACES\_1

`ACMSMGMT_LIST_INTERFACES_1` — ACMS Remote Manager clients call this procedure to obtain information about all configured interfaces for a Remote Manager server on a local or remote node.

### Format

`interfaces_rec_out *acmsmgmt_list_interfaces_1 (sub_id_struct *sub_rec, CLIENT *cl)`

### Parameters

#### sub\_rec

Type:	Sub_id_struct
Access:	Read
Mechanism:	By reference
Usage:	Structure that contains the following client authorization information.

<b>client_id</b>	
Type:	Integer
Access:	Read
Mechanism:	By value
Usage:	If explicit authentication is being used, a valid client ID must be provided. If the value for client_id is 0, proxy access is used. Client_id is obtained by calling the acms \$mgmt_get_creds procedure.

**cl**

Type:	CLIENT *
Access:	Read
Mechanism:	By value
Usage:	Pointer to an RPC client handle previously obtained by calling the RPC routine CLNT_CREATE.

**Return Value**

Type:	Interfaces_rec_out
Access:	Write
Mechanism:	By reference
Usage:	Pointer to a record that contains a union consisting of either a failure code or a pointer to the start of a linked list of records. See the Description section for a discussion of the structure of the union. The records contain all the fields of the Interfaces table (see Section 9.7).

**Description**

The ACMSMGMT\_LIST\_INTERFACES\_1 procedure returns an array of Remote Manager Interfaces table rows. All records in the table are returned. Each record represents a separate interface, as determined by the interface\_type field.

The return record is a union containing either a failure code or the first record in the list, as follows:

```

struct interfaces_rec_out {
    int status;
    union {
        interfaces_rec_out_r interfaces;
        int rc;
    } interfaces_rec_out_u;
};

```

To determine the status of the call and the contents of the return record, first check the status field. The following are possible values in the status field:

- MGMT\_FAIL

The call has failed and the rc field contains a specific error code describing the failure.

- MGMT\_SUCCESS

The call completed successfully. All rows in the table were returned.

The array is contained in a structure of type *interfaces\_rec\_out\_r* with an integer field (*num\_elements*) containing the size of the array, as follows:

```
struct interfaces_rec_out_r {
    int          num_elements;
    interfaces_rec  values[MGMT_K_MAX_IF];
};
```

## Example

```
int list_interfaces_data(int client_id, CLIENT *cl)
{
    interfaces_rec_out  *if_ptr;
    interfaces_rec_out_r *inter;
    static struct sub_id_struct sub_rec;
    int status;

    sub_rec.client_id = client_id;

    if_ptr = acmsgmt_list_interfaces_1(&sub_rec, cl);

    if (!if_ptr) {
        printf("\n RPC Call to get Interfaces data failed");
        return(MGMT_FAIL);
    }

    inter = &if_ptr->interfaces_rec_out_u.interfaces;
    if (if_ptr->status == MGMT_FAIL) {
        printf("\n Call to get Interfaces data failed, returning status code
            %d", if_ptr->interfaces_rec_out_u.rc);
        status = if_ptr->interfaces_rec_out_u.rc;
        xdr_free(xdr_interfaces_rec_out, if_ptr);
        free(if_ptr);
        return(status);
    }

    printf("\n RPC interface has processed %d read requests",
        inter->values[0].get_request_count);
    printf("\n SNMP interface has processed %d read requests",
        inter->values[1].get_request_count);
    xdr_free(xdr_interfaces_rec_out, if_ptr);
    free(if_ptr);
    return(0);
}
```

In the preceding example, the ACMSMGMT\_LIST\_INTERFACES\_1 procedure is called to fetch the contents of the Interfaces table. If the call succeeds, the number of read requests by each interface is printed from the retrieved record. Otherwise, an error message is displayed. The example in Section 6.4.1 shows how to declare and initialize the input arguments to this procedure.

## ACMSMGMT\_LIST\_LOG\_1

ACMSMGMT\_LIST\_LOG\_1 — ACMS Remote Manager clients call this procedure to obtain information from a Remote Manager log on a local or remote node.

### Format

log\_data\_list \*acmsmgmt\_list\_log\_1 (log\_sel\_struct \*log\_rec, CLIENT \*cl)

### Parameters

#### log\_rec

Type:	Log_sel_struct	
Access:	Read	
Mechanism:	By reference	
Usage:	Defines which log records to return. The log_sel_struct contains the following fields:	
	<b>client_id</b>	
Type:	Integer	
Access:	Read	
Mechanism:	By value	
Usage:	If explicit authentication is being used, a valid client ID must be provided. If the value for client_id is 0, proxy access is used.	
	<b>before_time</b>	
Type:	Null-terminated character string	
Access:	Read, optional	
Mechanism:	By reference	
Usage:	Pointer to a null-terminated character string containing a valid OpenVMS ASCII time string. This field determines the chronological starting point for the list of records to be returned. If omitted, records are returned beginning at the start of the file. Format is OpenVMS ASCII time ( <i>DD-MMM-YY HH:MM:SS.hh</i> ).	
	<b>since_time</b>	
Type:	Null-terminated character string	
Access:	Read, optional	
Mechanism:	By reference	

Usage:	Pointer to a null-terminated character string containing a valid OpenVMS ASCII time string. This field determines the chronological ending point for the list of records to be returned. If omitted, records are returned until end of file is reached. Format is OpenVMS ASCII time ( <i>DD-MMM-YY HH:MM:SS.hh</i> ).
<b>file_name</b>	
Type:	Null-terminated character string
Access:	Read, optional
Mechanism:	By reference
Usage:	Pointer to a null-terminated character string containing either a valid OpenVMS file specification or a logical name pointing to a valid OpenVMS file specification. This field determines the log file to be processed. An empty string requests the default (currently open) log file.
<b>dup_count</b>	
Type:	Integer
Access:	Read
Mechanism:	By value
Usage:	A sequential counter of records with the same time. This allows records to be unique even if they were generated at the same time. Set this value to -1 for the initial call.
<b>facility</b>	
Type:	Integer
Access:	Read, optional
Mechanism:	By value
Usage:	Value of a valid Remote Manager facility. If specified, only audit records with matching facility codes are returned.
<b>severity</b>	
Type:	Integer

Access:	Read, optional
Mechanism:	By value
Usage:	Value of a valid Remote Manager severity. If specified, only audit records with matching severity are returned.

**cl**

Type:	CLIENT *
Access:	Read
Mechanism:	By value
Usage:	Pointer to an RPC client handle previously obtained by calling the RPC routine CLNT_CREATE.

**Return Value**

Type:	Log_data_list																														
Access:	Write																														
Mechanism:	By reference																														
Usage:	<p>Pointer to a union. The union contains either a failure code or a pointer to the start of a linked list of records. See the Description section for a discussion of the structure of the union. The following are the contents of this record:</p> <table border="1"> <tr> <td colspan="2"><b>log_data_list</b></td> </tr> <tr> <td>Type:</td> <td>Logging_rec</td> </tr> <tr> <td>Access:</td> <td>Write</td> </tr> <tr> <td>Mechanism:</td> <td>By reference</td> </tr> <tr> <td>Usage:</td> <td>Pointer to a structure of type logging_rec.</td> </tr> <tr> <td colspan="2"><b>dup_count</b></td> </tr> <tr> <td>Type:</td> <td>Integer</td> </tr> <tr> <td>Access:</td> <td>Write</td> </tr> <tr> <td>Mechanism:</td> <td>By value</td> </tr> <tr> <td>Usage:</td> <td>Integer value with uniquely identifies records generated at the same time.</td> </tr> <tr> <td colspan="2"><b>log_msg</b></td> </tr> <tr> <td>Type:</td> <td>Null-terminated character string</td> </tr> <tr> <td>Access:</td> <td>Write</td> </tr> <tr> <td>Mechanism:</td> <td>By reference</td> </tr> <tr> <td>Usage:</td> <td>Pointer to a null-terminated character string containing the audit information.</td> </tr> </table>	<b>log_data_list</b>		Type:	Logging_rec	Access:	Write	Mechanism:	By reference	Usage:	Pointer to a structure of type logging_rec.	<b>dup_count</b>		Type:	Integer	Access:	Write	Mechanism:	By value	Usage:	Integer value with uniquely identifies records generated at the same time.	<b>log_msg</b>		Type:	Null-terminated character string	Access:	Write	Mechanism:	By reference	Usage:	Pointer to a null-terminated character string containing the audit information.
<b>log_data_list</b>																															
Type:	Logging_rec																														
Access:	Write																														
Mechanism:	By reference																														
Usage:	Pointer to a structure of type logging_rec.																														
<b>dup_count</b>																															
Type:	Integer																														
Access:	Write																														
Mechanism:	By value																														
Usage:	Integer value with uniquely identifies records generated at the same time.																														
<b>log_msg</b>																															
Type:	Null-terminated character string																														
Access:	Write																														
Mechanism:	By reference																														
Usage:	Pointer to a null-terminated character string containing the audit information.																														

<b>pNext</b>	
Type:	Log_list
Access:	Write
Mechanism:	By value
Usage:	Pointer to the next record in the linked list.

## Description

### Note

The ACMSMGMT\_LIST\_LOG\_1 procedure is also described in detail in Section 6.6.1.

The ACMSMGMT\_LIST\_LOG\_1 procedure returns a linked list of Remote Manager log entries, ordered by time. The records to be returned are determined by the fields specified in the **log\_sel\_struct** input argument. Records can be selected by date and time, facility, and severity. Note that only `max_rpc_return_rec` data (Parameter table field) is returned in each call. The end of data is signaled by the status field (see the following example). If the end of data is not signaled, repeated calls are needed to fetch all matching records.

The return record is a union containing either a failure code or the first record in the list:

```
struct log_data_list {
    int status;
    union {
        int rc;
        log_list list;
    } log_data_list_u;
};
```

To determine the status of the call and the contents of the return record, first check the status field. The following are possible values in the status field:

- MGMT\_FAIL

The call has failed and the `rc` field contains a specific error code describing the failure.

- MGMT\_NOMORE\_DATA

There are no more records in the file. The linked list may or may not contain the final records, depending on whether any more records matched the selection criteria.

- MGMT\_SUCCESS

The call completed successfully. More records exist than were returned in the call.

The ACMSMGMT\_LIST\_LOG\_1 procedure returns  $n$  records per call, where  $n$  is determined by the Remote Manager parameter field `max_rpc_return_recs`. Therefore, repeated calls may be necessary to retrieve all records that match the selection criteria. Context is not maintained by the server between calls; the selection criteria are evaluated on each call by the Remote Manager. Following the initial call, callers should place the correct time value in the `since_time` field of the **log\_sel\_struct** input argument, as well as the correct `dup_count` value in order to have the chronologically next  $n$  records returned.

This procedure does not require the ACMS run-time system to execute.

## Example

```
int list_log_data(int client_id,CLIENT *cl)
{
    int skip_rec          = 0;
    char null_time_str[24] = "";
    char first_of_jan[24] = "01-JAN-1998 00:00:00.00";
    char file_spec[]      = ""; /* use default, i.e. active log file */
    char time_cache[MGMT_S_TIME_A+1];
    static struct log_sel_struct log_rec;
    log_data_list *log;
    log_link *nl;
    int status;

    /* Initialize log selection data */

    log_rec.client_id    = client_id;
    log_rec.before_time  = null_time_str;
    log_rec.since_time   = first_of_jan;
    log_rec.file_name    = file_spec;
    log_rec.dup_count    = -1;
    log_rec.facility     = -1; /* don't match on facility */
    log_rec.severity     = -1; /* don't match on severity */

top:

    log = acmsmgmt_list_log_1(&log_rec,cl);

    if (!log)
        return(MGMT_FAIL);

    if (log->status == MGMT_FAIL) {
        status = log->log_data_list_u.rc;
        xdr_free(xdr_log_data_list, log);
        free(log);
        return(status);
    }

    for (nl = log->log_data_list_u.list; nl != NULL; nl = nl->pNext) {
        if (skip_rec)
            skip_rec = 0;
        else
            printf("\n %-12s\t%-s",sname,nl->log_data.log_msg);

            memcpy(&time_cache[0],nl->log_data.log_msg,23);
            log_rec.dup_count  = nl->log_data.dup_count;
            log_rec.since_time = time_cache;
    }

    if (log->status == MGMT_NOMORE_DATA)
        printf("\n *** End of data ***");

    else {
        skip_rec = 1;
        goto top;
    }
}
```



```

}

    xdr_free(xdr_log_data_list, log);
    free(log);
    return(0);
}

```

In the preceding example, the `ACMSMGMT_LIST_LOG_1` procedure is called to fetch the contents of the RM log file. All entries since January 1, 1998 are requested. If the call succeeds, each entry is printed out. Otherwise, an error message is displayed. This example is very similar to the one described in detail in Chapter 6.

## ACMSMGMT\_LIST\_PROC\_1

`ACMSMGMT_LIST_PROC_1` — ACMS Remote Manager clients call this procedure to obtain a list of ACMS processes running on a particular node, along with some collection state information for each process.

### Format

`proc_data_list *acmsmgmt_list_proc_1 (sub_id_struct *sub_rec, CLIENT *cl)`

### Parameters

#### sub\_rec

Type:	Sub_id_struct	
Access:	Read	
Mechanism:	By reference	
Usage:	Structure that contains the following client authorization information.	
	<b>client_id</b>	
	Type:	Integer
	Access:	Read
	Mechanism:	By value
	Usage:	If explicit authentication is being used, a valid client ID must be provided. If the value for <code>client_id</code> is 0, proxy access is used. <code>Client_id</code> is obtained by calling the <code>acms \$mgmt_get_creds</code> procedure.

#### cl

Type:	CLIENT *
Access:	Read
Mechanism:	By value
Usage:	Pointer to an RPC client handle previously obtained by calling the RPC routine <code>CLNT_CREATE</code> .

## Return Value

Type:	Proc_data_list	
Access:	Write	
Mechanism:	By reference	
Usage:	<p>Pointer to a record that contains a union consisting of either a failure code or a pointer to a structure of type proc_link, which contains the start of a linked list of records. The following are the contents of this union:</p>	
	<b>rc</b>	
Type:	Integer	
Access:	Write	
Mechanism:	By value	
Usage:	Failure return code.	
	<b>list</b>	
Type:	Proc_list	
Access:	Write	
Mechanism:	By reference	
Usage:	<p>Start of linked list. Pointer to a structure of process data, and a forward pointer to the next node in the linked list. The following are the contents of this structure:</p>	
	<b>pNext</b>	
Type:	Proc_list	
Access:	Write	
Mechanism:	By value	
Usage:	Start of linked list. Pointer to a structure of type user_list.	
	<b>proc_data</b>	
Type:	Proc_rec	
Access:	Write	
Mechanism:	By reference	
Usage:	<p>The data describing the process. This record contains the following fields:</p>	
	<b>record_state</b>	
Type:	Integer	
Access:	Write	
Mechanism:	By value	
Usage:	<p>The current state of the record. Will be either MGMT_VALID or MGMT_INACTIVE.</p>	

			<b>entity_type</b>
			Type: Integer
			Access: Write
			Mechanism: By value
			Usage: The type of ACMS entity the process is.
			<b>pid</b>
			Type: Integer
			Access: Write
			Mechanism: By value
			Usage: OpenVMS Process ID.
			<b>process_name</b>
			Type: Null-terminated string
			Access: Write
			Mechanism: By reference
			Usage: The OpenVMS process name.
			<b>class_states</b>
			Type: Array of integers
			Size: 5
			Access: Write
			Mechanism: By value
			Usage: An array of integers. Each array element represents the collection state for a class. Positions are: <ul style="list-style-type: none"> <li>• 0: ID</li> <li>• 1: CONFIG</li> <li>• 2: RUNTIME</li> <li>• 3: POOL</li> <li>• 4: ERROR</li> </ul>

## Description

The `ACMSMGMT_LIST_PROC_1` procedure returns a linked list of processes that a particular Remote Manager is aware of. The Remote Manager builds this list from the various ACMS Entity tables. For each process, the Remote Manager populates a `proc_data` record.

Note that some entity tables may contain rows with inactive data, that is, data for processes that are no longer active. The data in these rows may or may not be interesting to the caller. To distinguish active and inactive processes, the Remote Manager sets the `record_state` field to `MGMT_VALID` for active processes and to `MGMT_INACTIVE` for inactive processes. The caller is responsible for checking this field and taking appropriate action.

The `collection_states` field is a simple array of five integers. Each array element contains either a 1 (if the collection class is enabled) or a 0 (if the collection class is disabled). Array elements are positional, as described in the Return Value section.

Like other procedures that return linked lists, the return parameter is a union containing either a failure status code or a linked list of records.

To determine the status of the call and the contents of the return record, first check the status field. The following are possible values in the status field:

- `MGMT_FAIL`

The call has failed and the `rc` field contains a specific error code describing the failure.

- `MGMT_SUCCESS`

The call completed successfully. All user records have been returned.

If the status field value is `MGMT_SUCCESS`, a linked list has been returned. The linked list contains a structure containing the process data, and a forward pointer. By following the forward pointer, all the records in the list can be retrieved.

If the ACMS run-time system is not running when this call is issued, the Remote Manager returns the `MGMT_NOT_MAPPED` error code.

## Example

```
int list_process_data(int client_id, CLIENT *cl)
{
    proc_data_list *proc;
    proc_link      *nl;
    static struct sub_id_struct sub_rec;
    int status;

    sub_rec.client_id = client_id;

    proc = acmsgmt_list_proc_1(&sub_rec, cl);

    if (!proc) {
        printf("\n RPC Call to get Process data failed");
        return(MGMT_FAIL);
    }
}
```

```

    if ((proc->status != MGMT_SUCCESS) && (proc->status !=
MGMT_NOMORE_DATA)) {
        printf("\n Call to get Process data failed, returning status code
%d",
            proc->proc_data_list_u.rc);
        status = proc->proc_data_list_u.rc;
        xdr_free(xdr_proc_data_list, proc);
        free(proc);
        return(status);
    }

    for (nl = proc->proc_data_list_u.list; nl != NULL; nl = nl->pNext) {
        if (nl->proc_data.record_state == MGMT_INACTIVE)
            printf("\n INACTIVE ");
        else
            printf("\n          ");
        printf(" PID: %8X  Process Name: %s",nl->proc_data.pid,
            nl->proc_data.process_name);
    }

    printf("\n End of data");
    xdr_free(xdr_proc_data_list, proc);
    free(proc);
    return(0);
}

```

In the preceding example, the `ACMSMGMT_LIST_PROC_1` procedure is called to fetch information about collection states from all processes accessible to the Remote Manager. If the call succeeds, the name of the process, along with its state is displayed (inactive processes have that string printed before the process name). Otherwise, an error message is displayed.

## ACMSMGMT\_LIST\_SERVER\_1

`ACMSMGMT_LIST_SERVER_1` — ACMS Remote Manager clients call this procedure to obtain a list of procedure server table (Server table) entries.

### Format

`ser_data_list *acmsmgmt_list_server_1(ser_sel_struct *sub_rec, CLIENT *cl)`

### Parameters

#### sub\_rec

Type:	Ser_sel_struct	
Access:	Read	
Mechanism:	By reference	
Usage:	Structure that contains client information and procedure server selection criteria. The structure contains the following fields.	
	<b>client_id</b>	
	Type:	Integer
	Access:	Read

Mechanism:	By value
Usage:	If explicit authentication is being used, a valid client ID must be provided. If the value for client_id is 0, proxy access is used. Client_id is obtained by calling the acms \$mgmt_get_creds procedure.
<b>appl_name</b>	
Type:	Null-terminated string
Access:	Read
Mechanism:	By reference
Usage:	A pointer to an application name. The name may contain wildcard characters (*, !). Specify in all uppercase characters.
<b>server_name</b>	
Type:	Null-terminated string
Access:	Read
Mechanism:	By reference
Usage:	A pointer to a procedure server name. The name may contain wildcard characters (*, !). Specify in all uppercase characters.

**cl**

Type:	CLIENT *
Access:	Read
Mechanism:	By value
Usage:	Pointer to an RPC client handle previously obtained by calling the RPC routine CLNT_CREATE.

**Return Value**

Type:	Ser_data_list
Access:	Write
Mechanism:	By reference
Usage:	Pointer to a record that contains a union consisting of either a failure code or a pointer to a structure of type ser_link, which contains the start of a linked list of records. The following are the contents of this union:
<b>rc</b>	
Type:	Integer

Access:	Write
Mechanism:	By value
Usage:	Failure return code.
<b>list</b>	
Type:	Ser_list
Access:	Write
Mechanism:	By reference
Usage:	Start of linked list. Pointer to a structure containing an EXC table record, and a forward pointer to the next node in the linked list. The following are the contents of this structure:
<b>pNext</b>	
Type:	Ser_list
Access:	Write
Mechanism:	By value
Usage:	Start of linked list. Pointer to a structure of type coll_list.
<b>ser_data</b>	
Type:	Ser_rec_r
Access:	Write
Mechanism:	By reference
Usage:	Server table row. Server table fields are described in Section 9.11.

## Description

The ACMSMGMT\_LIST\_SER\_1 procedure returns a linked list of Server table rows. All matching Server table rows are returned in each call. Matching is performed first on application name, and then on server name. Therefore, all matching servers for all matching applications are returned.

Entire table rows are returned. See Section 9.11 for a description of the fields in the ser\_rec\_r structure.

If the ACMS run-time system is not running when this call is issued, the Remote Manager returns the MGMT\_NOT\_MAPPED error code.

Rows in the EXC table are subject to reuse. Rows are assigned round-robin, and are not cleared until they have been reassigned. Therefore, some rows may contain data for inactive EXCs. The Remote Manager attempts to retrieve server information for inactive EXCs. It is the caller's responsibility to examine the record\_state field to determine whether this row belongs to an active (record\_state field is MGMT\_VALID) or inactive (record\_state field is MGMT\_INACTIVE) EXC, and to process the row accordingly.

## Example

```
int list_ser_data(int client_id, CLIENT *cl)
{
```

```

static char c_all_appls[2] = "";
ser_data_list      *ser_data;
ser_link          *nl;
static struct ser_sel_struct sub_rec;
int status;

sub_rec.client_id = client_id;
sub_rec.appl_name = c_all_appls;
sub_rec.server_name = c_all_appls;

ser_data = acmsmgmt_list_server_1(&sub_rec,cl);

if (!ser_data) {
    printf("\n RPC Call to get Server data failed");
    return(MGMT_FAIL);
}

if (ser_data->status == MGMT_FAIL) {
    if (ser_data->ser_data_list_u.rc == MGMT_NOMORE_DATA) {
        printf("\n No SERVER data found");
        xdr_free(xdr_ser_data_list, ser_data);
        free(ser_data);
        return(MGMT_FAIL);
    }
    printf("\n Call to get Server data failed, returning status code
%d",
        ser_data->ser_data_list_u.rc);
    status = ser_data->ser_data_list_u.rc;
    xdr_free(xdr_ser_data_list, ser_data);
    free(ser_data);
    return(status);
}

if (ser_data->status == MGMT_WARN)
    printf("\n ** Warning, some data may be from inactive processes
**");

for (nl = ser_data->ser_data_list_u.list; nl != NULL; nl = nl->pNext) {
    if (nl->ser_data.record_state == MGMT_INACTIVE)
        printf("\n INACTIVE ");
    else
        printf("\n          ");
    printf(" Application : %-32s Server: %-s",
        nl->ser_data.appl_name,
        nl->ser_data.server_name);
}

printf("\n End of data");
xdr_free(xdr_ser_data_list, ser_data);
free(ser_data);
return(0);
}

```

In the preceding example, the `ACMSMGMT_LIST_SERVER_1` procedure is called to fetch the contents of the Server tables for all applications on the target node. If the call succeeds, the state of the server (if inactive), the name of the application it belongs to, and the name of the server are displayed for each table row returned. Otherwise, an error message is displayed.



## ACMSMGMT\_LIST\_TG\_2

ACMSMGMT\_LIST\_TG\_2 — ACMS Remote Manager clients call this procedure to obtain a list of Task Group table entries.

### Format

`tg_data_list_2 *acmsmgmt_list_tg_2(tg_sel_struct *sub_rec, CLIENT *cl)`

### Parameters

#### sub\_rec

Type:	Tg_sel_struct	
Access:	Read	
Mechanism:	By reference	
Usage:	Structure that contains client information and task group selection criteria. The structure contains the following fields.	
<b>client_id</b>		
Type:	Integer	
Access:	Read	
Mechanism:	By value	
Usage:	If explicit authentication is being used, a valid client ID must be provided. If the value for client_id is 0, proxy access is used. Client_id is obtained by calling the acms \$mgmt_get_creds procedure.	
<b>appl_name</b>		
Type:	Null-terminated string	
Access:	Read	
Mechanism:	By reference	
Usage:	A pointer to an application name. The name may contain wildcard characters (*, !). Specify in all uppercase characters.	
<b>tg_name</b>		
Type:	Null-terminated string	
Access:	Read	
Mechanism:	By reference	
Usage:	A pointer to a task group name. The name may contain wildcard characters (*, !). Specify in all uppercase characters.	

**cl**

Type:	CLIENT *
Access:	Read
Mechanism:	By value
Usage:	Pointer to an RPC client handle previously obtained by calling the RPC routine CLNT_CREATE.

**Return Value**

Type:	Tg_data_list_2	
Access:	Write	
Mechanism:	By reference	
Usage:	Pointer to a record that contains a union consisting of either a failure code or a pointer to a structure of type tg_link_2, which contains the start of a linked list of records. The following are the contents of this union:	
	<b>rc</b>	
	Type:	Integer
	Access:	Write
	Mechanism:	By value
	Usage:	Failure return code.
	<b>list</b>	
	Type:	Tg_list_2
	Access:	Write
	Mechanism:	By reference
	Usage:	Start of linked list. Pointer to a structure containing a Task Group table record, and a forward pointer to the next node in the linked list. The following are the contents of this structure:
	<b>pNext</b>	
	Type:	Tg_list_2
	Access:	Write
	Mechanism:	By value
	Usage:	Start of linked list. Pointer to a structure of type coll_list.
	<b>tg_data</b>	
	Type:	Tg_rec_r_2
	Access:	Write
	Mechanism:	By reference
	Usage:	Task Group table row. Task Group table fields are described in Section 9.12.

## Description

The `ACMSMGMT_LIST_TG_2` procedure returns a linked list of Task Group table rows. All matching Task Group table rows are returned in each call. Matching is performed first on the application name, and then on the task group name. Therefore, all matching task groups for all matching applications are returned.

Entire table rows are returned. See Section 9.12 for a description of the fields in the `tg_rec_r` structure.

If the ACMS run-time system is not running when this call is issued, the Remote Manager returns the `MGMT_NOT_MAPPED` error code.

Rows in the EXC table are subject to reuse. Rows are assigned round-robin, and are not cleared until they have been reassigned. Therefore, some rows may contain data for inactive EXCs. The Remote Manager will attempt to retrieve task group information for inactive EXCs. It is the caller's responsibility to examine the `record_state` field to determine whether this row belongs to an active (`record_state` field is `MGMT_VALID`) or inactive (`record_state` field is `MGMT_INACTIVE`) EXC, and to process the row accordingly.

## Example

```
int list_group_data(int client_id,CLIENT *cl)
{
    static char c_all_appls[2] = "*";
    tg_data_list_2 *tg_data;
    tg_link_2 *nl;
    static struct tg_sel_struct sub_rec;
    int status;

    sub_rec.client_id = client_id;
    sub_rec.appl_name = c_all_appls;
    sub_rec.tg_name = c_all_appls;

    tg_data = acmsmgmt_list_tg_2(&sub_rec,cl);

    if (!tg_data) {
        printf("\n RPC Call to get Task Group data failed");
        return(MGMT_FAIL);
    }

    if (tg_data->status == MGMT_FAIL) {
        if (tg_data->tg_data_list_2_u.rc == MGMT_NOMORE_DATA) {
            printf("\n No GROUP data found");
            xdr_free(xdr_tg_data_list_2, tg_data);
            free(tg_data);
            return(MGMT_FAIL);
        }
        printf("\n Call to get Task Group data failed, returning status code
            %d",tg_data->tg_data_list_2_u.rc);
        status = tg_data->tg_data_list_2_u.rc;
        xdr_free(xdr_tg_data_list_2, tg_data);
        free(tg_data);
        return(status);
    }

    if (tg_data->status == MGMT_WARN)
```

```

    printf("\n ** Warning, some data may be from inactive processes
**");

    for (nl = tg_data->tg_data_list_2_u.list; nl != NULL; nl = nl->pNext) {
        if (nl->tg_data.record_state == MGMT_INACTIVE)
            printf("\n INACTIVE ");
        else
            printf("\n          ");
        printf(" Application: %-32s Task Group: %-s",
              nl->tg_data.appl_name,
              nl->tg_data.tg_name);
    }

    printf("\n End of data");
    xdr_free(xdr_tg_data_list_2, tg_data);
    free(tg_data);
    return(0);
}

```

In the preceding example, the `ACMSMGMT_LIST_TG_1` procedure is called to fetch the contents of the Task Group tables for all applications on the target node. If the call succeeds, the state of the task group (if inactive), the name of the application it belongs to, and the name of the task group are displayed for each table row returned. Otherwise, an error message is displayed.

## ACMSMGMT\_LIST\_TRAP\_1

`ACMSMGMT_LIST_TRAP_1` — ACMS Remote Manager clients call this procedure to obtain a list of Trap table entries.

### Format

`trap_data_list *acmsmgmt_list_trap_1(sub_id_struct *sub_id_rec, CLIENT *cl)`

### Parameters

#### sub\_rec

Type:	Sub_id_struct *	
Access:	Read	
Mechanism:	By reference	
Usage:	Structure that contains the following client authorization information.	
	<i>client_id</i>	
	Type:	Integer
	Access:	Read
	Mechanism:	By value
	Usage:	If explicit authentication is being used, a valid client ID must be provided. If the value for <code>client_id</code> is 0, proxy access is used. <code>Client_id</code> is

	obtained by calling the acms \$mgmt_get_creds procedure.
--	--

**cl**

Type:	CLIENT *
Access:	Read
Mechanism:	By value
Usage:	Pointer to an RPC client handle previously obtained by calling the RPC routine CLNT_CREATE.

**Return Value**

Type:	Trap_data_list	
Access:	Write	
Mechanism:	By reference	
Usage:	Pointer to a union. The union contains either a failure code or a pointer to a structure of type trap_list, which contains the start of a linked list of records. The following are the contents of this union:	
	<i>rc</i>	
	Type:	Integer
	Access:	Write
	Mechanism:	By value
	Usage:	Failure return code.
	<i>list</i>	
	Type:	Trap_list
	Access:	Write
	Mechanism:	By reference
	Usage:	Start of linked list. Pointer to a structure of trap table rows, and a forward pointer to the next node in the linked list. The following are the contents of this structure:
	<i>pNext</i>	
	Type:	Proc_list
	Access:	Write
	Mechanism:	By value
	Usage:	Start of linked list. Pointer to a structure of type trap_list.
	<i>trap_data</i>	
	Type:	Trap_rec

		Access:	Write
		Mechanism:	By reference
		Usage:	Trap table row. Trap table fields are described in Section 9.13.

## Description

The `acmsmgmt_list_trap_1` procedure returns a linked list of Trap table rows. All Trap table rows are returned in each call. Records are returned sequentially from the table, beginning at the start of the table.

Entire table rows are returned. See Section 9.13 for a description of the fields in the `trap_rec` structure.

This procedure does not require the ACMS run-time system in order to execute.

## Example

```
int list_trap_data(int client_id, CLIENT *cl)
{
    char c_states[2][9] = {"enabled", "disabled"};
    char c_entities[10][9] = {"unknown", "*", "acc", "tsc", "qti", "cp", "exc",
                             "server", "group", "mgr"};
    char c_classes[6][8] = {"*", "id", "config", "runtime", "pool", "error"};
    char c_trap_params[2][15] = {"exists", "event severity"};

    trap_data_list *trap;
    trap_link      *nl;
    static struct sub_id_struct sub_rec;
    int status;

    sub_rec.client_id = client_id;

    trap = acmsmgmt_list_trap_1(&sub_rec, cl);

    if (!trap) {
        printf("\n RPC Call to get Trap data failed");
        return(MGMT_FAIL);
    }

    if (trap->status != MGMT_SUCCESS) {
        printf("\n Call to get Trap data failed, returning status code %d",
              trap->trap_data_list_u.rc);
        status = trap->trap_data_list_u.rc;
        xdr_free(xdr_trap_data_list, trap);
        free(trap);
        return(status);
    }

    for (nl = trap->trap_data_list_u.list; nl != NULL; nl = nl->pNext) {
        printf("\n Entity: %-9s Name: %-32s Param: %-15s Trap Min: %d
              Trap Max: %d",
              c_entities[nl->trap_data.entity_type],
              nl->trap_data.entity_name,
              c_trap_params[nl->trap_data.param_to_trap],
              nl->trap_data.min,
```

```

        nl->trap_data.max);
    }

    printf("\n End of data");
    xdr_free(xdr_trap_data_list, trap);
    free(trap);
    return(0);
}

```

In the preceding example, the `acmsmgmt_list_trap_1` procedure is called to fetch the contents of the Trap table. If the call succeeds, the `entity_type`, `entity_name`, `parameter`, `trap_min`, and `trap_max` fields are displayed for each row in the table. Otherwise, an error message is displayed. The example in Section 6.3.1 shows how to declare and initialize the input arguments to this procedure.

## ACMSMGMT\_LIST\_USERS\_1

`ACMSMGMT_LIST_USERS_1` — ACMS Remote Manager clients call this procedure to obtain information about users attached to a Remote Manager server on a local or remote node.

### Format

`user_data_list *acmsmgmt_list_users_1 (sub_id_struct *sub_rec, CLIENT *cl)`

### Parameters

#### `sub_rec`

Type:	Sub_id_struct	
Access:	Read	
Mechanism:	By reference	
Usage:	Structure that contains the following client authorization information.	
	<b>client_id</b>	
	Type:	Integer
	Access:	Read
	Mechanism:	By value
Usage:	If explicit authentication is being used, a valid client ID must be provided. If the value for <code>client_id</code> is 0, proxy access is used. <code>Client_id</code> is obtained by calling the <code>acms \$mgmt_get_creds</code> procedure.	

#### `cl`

Type:	CLIENT *
Access:	Read
Mechanism:	By value

Usage:	Pointer to an RPC client handle previously obtained by calling the RPC routine CLNT_CREATE.
--------	---

## Return Value

Type:	User_data_list
Access:	Write
Mechanism:	By reference
Usage:	<p>Pointer to a record that contains a union consisting of either a failure code or a pointer to a structure of type user_link, which contains the start of a linked list of records. The following are the contents of this union:</p>
<b>rc</b>	
Type:	Integer
Access:	Write
Mechanism:	By value
Usage:	Failure return code.
<b>list</b>	
Type:	User_list
Access:	Write
Mechanism:	By reference
Usage:	<p>Start of linked list. Pointer to a structure of user data, and a forward pointer to the next node in the linked list. The following are the contents of this structure:</p>
<b>pNext</b>	
Type:	User_list
Access:	Write
Mechanism:	By value
Usage:	Start of linked list. Pointer to a structure of type user_list.
<b>user_data</b>	
Type:	User_rec
Access:	Write
Mechanism:	By reference
Usage:	<p>The data describing the user. This record contains the following fields:</p>
<b>client_id</b>	
Type:	Integer
Access:	Write
Mechanism:	By value
Usage:	Integer value containing the



	client ID for the user.
<b>reserved</b>	
Type:	Integer
Access:	Write
Mechanism:	By value
Usage:	Reserved for VSI use.
<b>gid</b>	
Type:	Word
Access:	Write
Mechanism:	By value
Usage:	UIC group identifier.
<b>uid</b>	
Type:	Word
Access:	Write
Mechanism:	By value
Usage:	UIC user identifier.
<b>proxy_gid</b>	
Type:	Word
Access:	Write
Mechanism:	By value
Usage:	UIC group identifier of the proxy user, if proxy is being used.
<b>proxy_uid</b>	
Type:	Word
Access:	Write
Mechanism:	By value
Usage:	UIC user identifier of the proxy user, if proxy is being used.
<b>node-name</b>	
Type:	Null-terminated string
Access:	Write

Mechanism:	By reference
Usage:	Pointer to a null-terminated string containing the name of the node from which the user logged in.
<b>expires</b>	
Type:	Null-terminated string
Access:	Write
Mechanism:	By reference
Usage:	Time the user's credentials expire. Time is expressed in OpenVMS ASCII time format ( <i>DD-MMM-YYYY HH:MM:SS.hh</i> ).
<b>user-name</b>	
Type:	Null-terminated string
Access:	Write
Mechanism:	By reference
Usage:	Pointer to a null-terminated string containing the user name.
<b>rights</b>	
Type:	Array of integers
Access:	Write
Mechanism:	By value
Usage:	ACMS management rights identifiers held by the user.
<b>proxy_flag</b>	
Type:	Integer
Access:	Write
Mechanism:	By value
Usage:	Indicates whether the record is for a proxy user ( <code>proxy_flag = 1</code> ) or

				is not for a proxy user (proxy_flag = 0).
--	--	--	--	---

## Description

The `ACMSMGMT_LIST_USERS_1` procedure returns a linked list of users who are logged in to a particular Remote Manager. All user records are returned on each call to this procedure.

Like other procedures that return linked lists, the return parameter is a union containing either a failure status code or a linked list of records.

To determine the status of the call and the contents of the return record, first check the status field. The following are possible values for the status field:

- `MGMT_FAIL`

The call has failed, and the `rc` field contains a specific error code describing the failure.

- `MGMT_SUCCESS`

The call completed successfully. All user records have been returned.

If the status field is equal to `MGMT_SUCCESS`, a linked list has been returned. The linked list contains a structure containing the user data and a forward pointer. By following the forward pointer, all the records in the list can be retrieved.

This procedure does not require the ACMS run-time system to execute.

## Example

```
int list_users_data(int client_id, CLIENT *cl)
{
    user_data_list *user;
    user_link *nl;
    static struct sub_id_struct sub_rec;
    int status;

    sub_rec.client_id = client_id;

    user = acmsgmt_list_users_1(&sub_rec, cl);

    if (!user) {
        printf("\n RPC Call to get User data failed");
        return(MGMT_FAIL);
    }

    if ((user->status != MGMT_SUCCESS) && (user->status !=
MGMT_NOMORE_DATA)) {
        printf("\n Call to get User data failed, returning status code %d",
            user->user_data_list_u.rc);
        status = user->user_data_list_u.rc;
        xdr_free(xdr_user_data_list, user);
        free(user);
        return(status);
    }
}
```

```

for (nl = user->user_data_list_u.list; nl != NULL; nl = nl->pNext)
    printf("\n User %s is logged in from node %s",nl->user_data.uname,
        nl->user_data.nodename);

printf("\n End of data");
xdr_free(xdr_user_data_list, user);
free(user);
return(0);
}

```

In the preceding example, the `ACMSMGMT_LIST_USERS_1` procedure is called to fetch information about the users who have logged in to the Remote Manager. If the call succeeds, the name of the user and the node they logged in from are displayed. Otherwise, an error message is displayed. Note that the name displayed is the name by which the user is known to the server, and may be a proxy account. The example in Section 6.3.1 shows how to declare and initialize the input arguments to this procedure.

## ACMSMGMT\_REPLACE\_SERVER\_1

`ACMSMGMT_REPLACE_SERVER_1` — This procedure requests the Remote Manager to replace an ACMS procedure server in an ACMS application on the same node on which the Remote Manager is running.

### Format

```
cmd_output_rec *acmsmgmt_replace_server_1(ser_sel_struct *sub_rec,CLIENT *cl)
```

### Parameters

#### sub\_rec

Type:	Ser_sel_struct	
Access:	Read	
Mechanism:	By reference	
Usage:	Structure that contains client information and procedure server selection criteria. The structure contains the following fields.	
	<b>client_id</b>	
	Type:	Integer
	Access:	Read
	Mechanism:	By value
	Usage:	If explicit authentication is being used, a valid client ID must be provided. If the value for <code>client_id</code> is 0, proxy access is used. <code>Client_id</code> is obtained by calling the <code>acms \$mgmt_get_creds</code> procedure.
	<b>appl_name</b>	

Type:	Null-terminated string
Access:	Read
Mechanism:	By reference
Usage:	A pointer to an application name. The name may contain wildcard characters (*, !). Specify in all uppercase characters.
<b>server_name</b>	
Type:	Null-terminated string
Access:	Read
Mechanism:	By reference
Usage:	A pointer to a procedure server name. The name may contain wildcard characters (*, !). Specify in all uppercase characters.

**cl**

Type:	CLIENT *
Access:	Read
Mechanism:	By value
Usage:	Pointer to an RPC client handle previously obtained by calling the RPC routine CLNT_CREATE.

**Return Value**

Type:	Cmd_output_rec
Access:	Write
Mechanism:	By reference
Usage:	Pointer to a union. The union contains either a failure code or a structure of type cmd_rec, which points to a linked list containing status messages. The following are the contents of this union:
<b>status</b>	
Type:	Integer
Access:	Write
Mechanism:	By value
Usage:	Failure return code.
<b>rc</b>	
Type:	Integer
Access:	Write
Mechanism:	By value

Usage:	Failure return code.	
<b>data, data_warn</b>		
Type:	Cmd_rec	
Access:	Write	
Mechanism:	By value	
Usage:	Structure containing the first node in a linked list of status messages (type dcl_list). The following are the contents of this structure:	
<b>cmd_output</b>		
Type:	Dcl_list	
Access:	Write	
Mechanism:	By reference	
Usage:	Pointer to a linked list of records containing status messages related to the failure of any updates. This structure contains the following fields:	
<b>dcl_msg</b>		
Type:	Null-terminated string	
Access:	Write	
Mechanism:	By reference	
Usage:	The status message.	
<b>pNext</b>		
Type:	Dcl_list	
Access:	Write	
Mechanism:	By reference	
Usage:	Pointer to the next node in the linked list.	

## Description

This procedure requests to have an ACMS procedure server replaced (stopped and started) in an application that is running on the same node on which the Remote Manager is running. The combination of appl\_name and server\_name in the input record determines which server will be replaced.

This call executes synchronously. It does not return to the caller until the attempt to replace the server is complete. Any messages associated with an unsuccessful replacing of the server are returned in the cmd\_output linked list.

The data and data\_warn structures contain identical data. If the operation fails, the status field of both structures will be MGMT\_WARN; in this case, use the data\_warn structure to fetch the status messages from the cmd\_output linked list.

If the operation is successful, the status field of both structures will be `MGMT_SUCCESS`. There are no status messages associated with a successful call.

If the status field contains `MGMT_FAIL`, the call failed. There are no status messages returned; instead, the reason for the failure is contained in the `rc` field.

## Example

```
int replace_server(int client_id, CLIENT *cl)
{
    dcl_link      *nl;
    static char c_name_all[2] = "*";
    static char vr_read_server[] = "VR_READ_SERVER";
    static struct ser_sel_struct sub_rec;
    static cmd_output_rec *ret_struct;

    sub_rec.client_id = client_id;
    sub_rec.appl_name = c_name_all;
    sub_rec.server_name = vr_read_server;

    ret_struct = acmsgmt_replace_server_1(&sub_rec, cl);

    if (!ret_struct) {
        printf("\n Call to replace server failed");
        return(MGMT_FAIL);
    }

    if (ret_struct->status != MGMT_SUCCESS) {

        if (ret_struct->status != MGMT_WARN) {
            printf("\nCall to replace procedure server %s failed",
                sub_rec.server_name);
            return(MGMT_FAIL);
        }

        printf("\n Call to replace procedure server %s completed with warnings
or
        errors", sub_rec.server_name);

        for (nl = ret_struct->cmd_output_rec_u.data.cmd_output; nl != NULL;
            nl = nl->pNext)
            printf("\n %s", nl->dcl_msg);
        xdr_free(xdr_cmd_output_rec, ret_struct);
        free(ret_struct);
        return(MGMT_FAIL);
    }

    else {
        printf("\nCall to replace procedure server %s was executed",
            sub_rec.server_name);
        for (nl = ret_struct->cmd_output_rec_u.data.cmd_output; nl != NULL;
            nl = nl->pNext)
            printf("\n %s", nl->dcl_msg);
    }
    xdr_free(xdr_cmd_output_rec, ret_struct);
    free(ret_struct);
    return(0);
}
```

}

In the preceding example, the `acmsmgmt_replace_server_1` procedure is called to replace servers named `VR_READ_SERVER` in any application on the target node. If the call succeeds, all `VR_READ_SERVER` servers are replaced (stopped and started). Otherwise, any error messages associated with the failure are displayed. The example in Section 6.3.1 shows how to declare and initialize the input arguments to this procedure.

## ACMSMGMT\_RESET\_LOG\_1

`ACMSMGMT_RESET_LOG_1` — This procedure requests the Remote Manager to close the current version of its log file and open a new one.

### Format

```
int *acmsmgmt_reset_log_1(sub_id_struct *sub_rec,CLIENT *cl)
```

### Parameters

#### sub\_rec

Type:	Sub_id_struct	
Access:	Read	
Mechanism:	By reference	
Usage:	Structure that contains the following client authorization information.	
	<b>client_id</b>	
	Type:	Integer
	Access:	Read
	Mechanism:	By value
	Usage:	If explicit authentication is being used, a valid client ID must be provided. If the value for <code>client_id</code> is 0, proxy access is used. <code>Client_id</code> is obtained by calling the <code>acms_mgmt_get_creds</code> procedure.

#### cl

Type:	CLIENT *
Access:	Read
Mechanism:	By value
Usage:	Pointer to an RPC client handle previously obtained by calling the RPC routine <code>CLNT_CREATE</code> .

### Return Value

Type:	Integer
-------	---------



Access:	Write
Mechanism:	By reference
Usage:	Pointer to a status code containing a success or failure status code. MGMT_SUCCESS indicates success. Other values indicate failure.

## Description

This procedure requests the Remote Manager to close the currently open version of its log and to open a new one. All subsequent log entries are posted to the new version, and the old version can be safely removed.

## Example

```
int reset_log_data(int client_id,CLIENT *cl)
{
    static struct sub_id_struct sub_rec;
    int *status;

    sub_rec.client_id = client_id;

    status = acmsmgmt_reset_log_1(&sub_rec,cl);

    if (!status) {
        printf("\n Call to reset log failed");
        return(MGMT_FAIL);
    }

    if (*status != MGMT_SUCCESS) {
        printf("\n Call to reset log failed with status %d",*status);
        free(status);
        return(MGMT_FAIL);
    }
    else
        printf("\n Call to reset log completed");
        free(status);
    return(0);
}
```

In the preceding example, the `acmsmgmt_reset_log_1` procedure is called to close the current Remote Manager log and to open a new one. If the call succeeds, a success message is displayed. Otherwise, an error message is displayed. The example in Section 6.3.1 shows how to declare and initialize the input arguments to this procedure.

## ACMSMGMT\_RESET\_ERR\_2

`ACMSMGMT_RESET_ERR_2` — This procedure requests the Remote Manager to close the current version of the error log file and open a new one.

### Format

```
int *acmsmgmt_reset_err_2(sub_id_struct *sub_rec,CLIENT *cl)
```

## Parameters

### sub\_rec

Type:	Sub_id_struct	
Access:	Read	
Mechanism:	By reference	
Usage:	Structure that contains the following client authorization information.	
	<b>client_id</b>	
	Type:	Integer
	Access:	Read
	Mechanism:	By value
	Usage:	If explicit authentication is being used, a valid client ID must be provided. If the value for client_id is 0, proxy access is used. Client_id is obtained by calling the acms \$mgmt_get_creds procedure.

### cl

Type:	CLIENT *
Access:	Read
Mechanism:	By value
Usage:	Pointer to an RPC client handle previously obtained by calling the RPC routine CLNT_CREATE.

## Return Value

Type:	Integer
Access:	Write
Mechanism:	By reference
Usage:	Pointer to a status code containing a success or failure status code. MGMT_SUCCESS indicates success. Other values indicate failure.

## Description

This procedure requests the Remote Manager to close the currently open version of the error log and to open a new one. All subsequent error log entries are posted to the new version, and the old version can be safely removed.

## Example

```
int reset_err_data(int client_id, CLIENT *cl)
{
```

```

static struct sub_id_struct sub_rec;
int *status;

sub_rec.client_id = client_id;

status = acmsmgmt_reset_err_2(&sub_rec,cl);

if (!status) {
    printf("\n Call to reset log failed");
    return(MGMT_FAIL);
}

if (*status != MGMT_SUCCESS) {
    printf("\n Call to reset log failed with status %d",*status);
    free(status);
    return(MGMT_FAIL);
}
else
    printf("\n Call to reset log completed");
    free(status);
return(0);
}

```

In the preceding example, the `ACMSMGMT_RESET_ERR_2` procedure is called to close the current error log and to open a new one. If the call succeeds, a success message is displayed. Otherwise, an error message is displayed.

## ACMSMGMT\_SAVE\_ERR\_FILTER\_2

`ACMSMGMT_SAVE_ERR_FILTER_2` — This procedure saves the current error filter records to an error filter file.

### Format

```
int *acmsmgmt_save_err_filter_2(sub_id_struct *sub_rec,CLIENT *cl)
```

### Parameters

#### set\_struct

Type:	Err_filter_config_rec_r_2	
Access:	Read	
Mechanism:	By reference	
Usage:	Structure that contains the following client authorization and error filter record information.	
	<b>client_id</b>	
	Type:	Integer
	Access:	Read
	Mechanism:	By value
	Usage:	If explicit authentication is being used, a valid client

	ID must be provided. If the value for <code>client_id</code> is 0, proxy access is used. <code>Client_id</code> is obtained by calling the <code>acms \$mgmt_get_creds</code> procedure.
<b>err_filter_file_name</b>	
Type:	file_spec
Access:	Read
Mechanism:	By value
Usage:	Specifies the OpenVMS file specification for the error filter file.
<b>err_msg_name</b>	
Type:	String
Access:	Read
Mechanism:	By value
Usage:	Symbolic name of the error message.
<b>err_code</b>	
Type:	String
Access:	Read
Mechanism:	By value
Usage:	Decimal or hexadecimal code for the error message.

**cl**

Type:	CLIENT *
Access:	Read
Mechanism:	By value
Usage:	Pointer to an RPC client handle previously obtained by calling the RPC routine <code>CLNT_CREATE</code> .

**Return Value**

Type:	Integer
Access:	Write
Mechanism:	By reference
Usage:	Pointer to a status code containing a success or failure status code. <code>MGMT_SUCCESS</code> indicates success. Other values indicate failure.

**Description**

This procedure saves all records in the Error Filter table to the specified ASCII text file.

## Example

```

int save_err_filter( int client_id, CLIENT *cl)
{
    int *status;
    static char c_null_str[2] = "";
    static char file_spec = "sys$login:err_filter.dat";
    err_filter_config_rec_r_2 set_struct;

    set_struct.client_id = client_id;
    set_struct.err_filter_file_name = file_spec;
    set_struct.err_msg_name = c_null_str;
    set_struct.err_code = -2;

    status = acmsmgmt_save_err_filter_file_2(&set_struct, cl);

    if (!status) {
        printf("\n Call to save error filter failed");
        return(MGMT_FAIL);
    }

    if (*status != MGMT_SUCCESS) {
        printf("\n Call to save error filter failed with status %d",
            *status);
        free(status);
        return(MGMT_FAIL);
    }
    else {
        printf("\n Call to save error filter completed");
    }

    free(status);
    return(0);
}

```

In the preceding example, the `ACMSMGMT_SAVE_ERR_FILTER_2` procedure is called to save all the records in the Error Filter table to the file `SYSS$LOGIN:ERR_FILTER.DAT`. If the call succeeds, a success message is displayed. Otherwise, an error message is displayed.

## ACMSMGMT\_SET\_ACC\_2

`ACMSMGMT_SET_ACC_2` — This procedure modifies ACMS Central Controller (ACC) Config class fields.

### Format

```
acc_status_rec_2 *acmsmgmt_set_acc_2(acc_config_rec_2 *set_struct,CLIENT *cl)
```

### Parameters

#### set\_struct

Type:	Acc_config_rec
Access:	Read
Mechanism:	By reference

Usage:	Structure that contains the following client identification and ACC table fields.	
	<i>client_id</i>	
Type:	Integer	
Access:	Read	
Mechanism:	By value	
Usage:	If explicit authentication is being used, a valid client ID must be provided. If the value for <i>client_id</i> is 0, proxy access is used. <i>Client_id</i> is obtained by calling the acms \$mgmt_get_creds procedure.	
	<i>active_sw</i>	
Type:	Integer	
Access:	Read	
Mechanism:	By value	
Usage:	Indicates whether active variables should be updated ( <i>active_sw</i> = 1). Active variables are currently in use by the ACMS system; updates to active variables take effect immediately but are not durable (that is, they do not survive a restart of the ACMS system). Not all variables are dynamic, however. Refer to Section 9.2, and to the field descriptions in this section, to determine whether a particular variable can be updated dynamically.	
	<i>current_sw</i>	
Type:	Integer	
Access:	Read	
Mechanism:	By value	
Usage:	Indicates whether current variables should be updated ( <i>current_sw</i> = 1). Current variables are those stored in the ACMSGEN file currently in use by the ACMS system and are durable (that is, they can survive	

	a restart of the ACMS system). Updates to current variables take effect when the ACMS system is restarted.
<i>acc_priority, audit_state, max_appl, mss_maxobj, mss_maxbuf, mss_poolsize, wsc_poolsize, tws_poolsize, twsc_poolsize</i>	
Type:	Integer
Access:	Read
Mechanism:	By value
Usage:	Values to be updated. These fields correspond to fields of the same names in the ACC table, depending on the value of active_sw and current_sw in this record (for example, acc_priority will update the acc_priority_active field if active_sw is equal to 1). See Section 9.2 for a discussion of these fields. Note that not all fields can be updated dynamically.
<i>acc_username, username_default, node_name</i>	
Type:	Null-terminated string
Access:	Read
Mechanism:	By reference
Usage:	Values to be updated. These fields correspond to fields of the same names in the ACC table, depending on the value of active_sw and current_sw in this record (for example, username_default will update the username_default_active field if active_sw is equal to 1). See Section 9.2 for a discussion of these fields. Note that not all fields can be updated dynamically. In order to have any of these fields set to null (that is, ""), set the field to the string "NULL".

**cl**

Type:	CLIENT *
-------	----------

Access:	Read
Mechanism:	By value
Usage:	Pointer to an RPC client handle previously obtained by calling the RPC routine CLNT_CREATE.

## Return Value

Type:	Struct <code>acc_status_rec</code>	
Access:	Write	
Mechanism:	By reference	
Usage:	<p>Pointer to a union. The union contains either a failure code or a structure of type <code>acc_config_rec_out</code>, which contains status codes for each field, as well as a linked list of status messages associated with the update. See the Description section for a discussion of how to determine the update status for any field. The following are the contents of this union:</p>	
	<i>status</i>	
	Type:	Integer
	Access:	Write
	Mechanism:	By value
	Usage:	Failure return code.
	<i>data, data_warn</i>	
	Type:	<code>Acc_config_rec_out</code>
	Access:	Write
	Mechanism:	By value
	Usage:	Structure containing fields corresponding to the fields in the <code>acc_config_rec</code> structure, as well as a linked list of status messages associated with the update. See the Description section for a discussion of how to determine the update status for any field. The following are the contents of this structure:
	<i>acc_priority, audit_state, max_appl, mss_maxobj, mss_maxbuf, mss_poolsize, wsc_poolsize, tws_poolsize, twsc_poolsize</i>	
	Type:	Integer
	Access:	Write
	Mechanism:	By value
	Usage:	Status fields corresponding to the fields in the input argument.
	<i>acc_username, username_default, node_name</i>	



	Type:	Null-terminated string
	Access:	Write
	Mechanism:	By reference
	Usage:	These fields contain the values that were supplied in the input argument, and can be ignored.
	<i>cmd_output</i>	
	Type:	Dcl_list
	Access:	Write
	Mechanism:	By reference
	Usage:	Pointer to a linked list of records containing status messages related to the failure of any updates. This structure contains the following fields:
	<i>dcl_msg</i>	
	Type:	Null-terminated string
	Access:	Write
	Mechanism:	By reference
	Usage:	The status message.
	<i>pNext</i>	
	Type:	Dcl_list
	Access:	Write
	Mechanism:	By reference
	Usage:	Pointer to the next node in the linked list.

## Description

This procedure requests updates to ACMS ACC Config class fields contained in the ACC table (see Section 9.2). Note that the ACC table contains both active and stored values. The `active_sw` field and `current_sw` field control which fields are to be updated.

Attempting to update an active field that is nondynamic is essentially useless, since the value of the active field value will not change. For instance, calling this procedure with the `active_sw` field set to 1 and the `acc_username` field populated produces no change to the system.

Setting the `current_sw` field to 1 causes updates to be written to the current ACMSGEN file. These updates are durable, that is, they can survive a restart of the ACMS system, but they do not affect the active system until the system is restarted.

Both `current_sw` and `active_sw` can be set on a given call. If they are, both the active and stored values for any nonnegative or nonnull fields will be updated.

For any nonnegative integer fields, the completion status of the update is returned in the corresponding field in the return structure. For string fields, the string field value is returned regardless of the status of the call.

In order to have one of the string fields set to a null string, that is, "", populate the field with the value NULL. To have one of the string fields ignored, pass in a null string.

## Example

```
int set_acc_data(int client_id,CLIENT *cl)
{
    static char c_name_all[2] = "*";
    static char c_null_str[2] = "";
    static acc_config_rec_2 set_struct;
    acc_status_rec_2      *ret_struct;
    dcl_link              *nl;

    memset(&set_struct,-1,sizeof(set_struct));
    set_struct.client_id   = client_id;
    set_struct.active_sw   = 1;
    set_struct.current_sw  = 0;
    set_struct.audit_state = MGMT_STATE_DISABLED;

    /* Have to provide a pointer for string conversions by XDR
       or it will access vio. RM will ignore any fields with
       strlen of 0 */
    set_struct.acc_username = c_null_str;
    set_struct.username_default = c_null_str;
    set_struct.node_name = c_null_str;

    ret_struct = acmsgmt_set_acc_2(&set_struct,cl);

    if (!ret_struct) {
        printf("\n Call to modify ACC failed");
        return(MGMT_FAIL);
    }

    if (ret_struct->status != MGMT_SUCCESS)
        printf("\n Call to modify ACC returned the following warnings or
            errors\n");
    else
        printf("\n Call to modify ACC completed\n");

    for (nl = ret_struct->acc_status_rec_2_u.data.cmd_output; nl != NULL;
         nl = nl->pNext)
        printf("\n %s",nl->dcl_msg);
        xdr_free(xdr_acc_status_rec_2, ret_struct);
        free(ret_struct);
    return(0);
}
```

In the preceding example, the `acmsgmt_set_acc_1` procedure is called to disable system auditing on the target node. If the call succeeds, system auditing is disabled on the target node, and a success

message is displayed. Otherwise, an error message is displayed. The example in Section 6.3.1 shows how to declare and initialize the input arguments to this procedure.

## ACMSMGMT\_SET\_COLLECTION\_2

ACMSMGMT\_SET\_COLLECTION\_2 — This procedure modifies entries in the Remote Manager Collection table. Collection table entries can also be added and deleted.

### Format

`coll_status_rec_2 *acmsmgmt_set_collection_2(coll_config_rec_2 *set_struct, CLIENT *cl)`

### Parameters

#### set\_struct

Type:	Coll_config_rec		
Access:	Read		
Mechanism:	By reference		
Usage:	Structure that contains the following client identification and collection table fields.		
	<i>client_id</i>		
	Type:	Integer	
	Access:	Read	
	Mechanism:	By value	
	Usage:	If explicit authentication is being used, a valid client ID must be provided. If the value for <i>client_id</i> is 0, proxy access is used. <i>Client_id</i> is obtained by calling the <code>acms \$mgmt_get_creds</code> procedure.	
	<i>coll</i>		
	Type:	Struct <code>coll_update_rec_r</code>	
	Access:	Read	
	Mechanism:	By value	
	Usage:	Structure containing a Collection table record. Collection table fields are described in Section 9.4. See the Description section for information on how to initialize this record.	

#### cl

Type:	CLIENT *
-------	----------

Access:	Read
Mechanism:	By value
Usage:	Pointer to an RPC client handle previously obtained by calling the RPC routine CLNT_CREATE.

## Return Value

Type:	Struct coll_status_rec	
Access:	write	
Mechanism:	By reference	
Usage:	Pointer to a union. The union contains either a failure code or a structure of type coll_update_rec_r, which contains status codes for each field. See the Description section for a discussion of how to determine the update status for any field. The following are the contents of this union:	
	<i>status</i>	
	Type:	Integer
	Access:	write
	Mechanism:	By value
	Usage:	Failure return code.
	<i>data_warn</i>	
	Type:	Coll_update_rec_r
	Access:	write
	Mechanism:	By value
	Usage:	Structure containing a Collection table record. The entries in this field contain status codes that correspond to the fields in the coll structure. See the Description section for a discussion of how to determine the update status for any field.

## Description

This procedure requests updates to fields in the Collection table (see Section 9.4).

Updates to this table are not durable; that is, they do not survive a restart of the Remote Manager. To make nondynamic, permanent updates to the collection table, use the ACMSCFG utility.

Calls to this procedure must specify `entity_type`, `entity_name`, and `collection_class`. These fields must exactly match an existing record in the Collection table for the update to be applied. Table 8.1 and Table 8.4 contain symbolic values used to populate the `collection_class` and `entity_type` fields; `entity_name` is specified as a null-terminated string.

For any nonnegative fields, the completion status of the update is returned in the corresponding field in the return structure. This includes the key fields of `entity_type`, `entity_name`, and `collection_class`. If no matching record is found in the table, `entity_type` and `collection_class` contain values of `MGMT_FAIL`.

Updates to the collection table are processed immediately and may affect more than one ACMS process. See Section 5.1 for discussion of how the collection table affects ACMS data collection.

## Example

```
int set_collection_data(int client_id, CLIENT *cl)
{
    static char c_name_all[2] = "*";
    static coll_config_rec_2 set_struct;
    struct coll_status_rec_2 *status_rec;

    set_struct.client_id           = client_id;
    set_struct.coll.entity_type    = MGMT_ALL;
    set_struct.coll.entity_name    = c_name_all;
    set_struct.coll.collection_class = MGMT_CLASS_RT;
    set_struct.coll.collection_state = MGMT_STATE_ENABLED;

    status_rec = acmsgmt_set_collection_2(&set_struct, cl);
    if (!status_rec) {
        printf("\n Call to modify collection failed");
        return(MGMT_FAIL);
    }

    if (status_rec->status == MGMT_WARN) {
        printf("\nThe following updates failed: ");
        if (status_rec->coll_status_rec_2_u.data_warn.entity_type ==
MGMT_FAIL)
            printf("\n    Record not found");
        if (status_rec->coll_status_rec_2_u.data_warn.collection_state
            == MGMT_FAIL)
            printf("\n    coll_state invalid");
        if (status_rec->coll_status_rec_2_u.data_warn.storage_state ==
MGMT_FAIL)
            printf("\n    storage_state invalid");
        if (status_rec->coll_status_rec_2_u.data_warn.storage_interval
            == MGMT_FAIL)
            printf("\n    storage_interval invalid");
    }

    else if (status_rec->status != MGMT_SUCCESS) {
        printf("\n Call to modify collection failed with status
            %d", status_rec->coll_status_rec_2_u.rc);
        xdr_free(xdr_coll_status_rec_2, status_rec);
        free(status_rec);
        return(MGMT_FAIL);
    }
    else
        printf("\nCall to modify collection was executed");
        xdr_free(xdr_coll_status_rec_2, status_rec);
        free(status_rec);
        return(0);
}
```

}

In the preceding example, the `acmsmgmt_set_collection_1` procedure is called to set the collection state to `ENABLED` for the Collection table record with entity of `*` (all), name of `*` (all), and class of `RUNTIME`. If the call set the collection state to `ENABLED` for the Collection table record with an entity of `*` (all), a name of `*` (all), and class of `RUNTIME`. If the call succeeds, the new value will be stored in the Collection table, all ACMS processes on the target node will begin collecting run-time data, and a success message will be displayed. Otherwise, an error message is displayed. The example in Section 6.3.1 shows how to declare and initialize the input arguments to this procedure.

## ACMSMGMT\_SET\_CP\_2

`ACMSMGMT_SET_CP_2` — This procedure modifies the ACMS Central Process (CP) class attributes.

### Format

```
cp_status_rec_2 *acmsmgmt_set_cp_2(cp_config_rec_2 *cp_cfg_rec, CLIENT *cl)
```

### Parameters

#### `cp_cfg_rec_2`

Type:	Cp_config_rec	
Access:	Read	
Mechanism:	By reference	
Usage:	Structure that contains the following client identification and collection table fields.	
	<b>client_id</b>	
Type:	Integer	
Access:	Read	
Mechanism:	By value	
Usage:	If explicit authentication is being used, a valid client ID must be provided. If the value for <code>client_id</code> is 0, proxy access is used. <code>Client_id</code> is obtained by calling the <code>acms \$mgmt_get_creds</code> procedure.	
	<b>astlm, biolm, bytln, current_sw, diolm, enqlm, fillm, pgflquota, tqelm, wsdefault, wsextent, wsquota</b>	
Type:	Cp_rec_r	
Access:	Read	
Mechanism:	By value	
Usage:	Structure containing a CP table record. CP table fields are described in . See the Description section for	

	information on how to initialize this record.
--	---

**cl**

Type:	CLIENT *
Access:	Read
Mechanism:	By value
Usage:	Pointer to an RPC client handle previously obtained by calling the RPC routine CLNT_CREATE.

**Return Value**

Type:	Cp_status_rec_2
Access:	write
Mechanism:	By reference
Usage:	Pointer to a record that contains a union consisting of either a failure code or a structure of type config_rec_out_2, which contains status codes for each field. See the Description section for a discussion of how to determine the update status for any field. The following are the contents of this union:
<b>rc</b>	
Type:	Integer
Access:	write
Mechanism:	By value
Usage:	Failure return code.
<b>data_warn</b>	
Type:	Config_rec_out_2
Access:	write
Mechanism:	By value
Usage:	Structure containing a CP table record. The entries in this field contain status codes that correspond to the fields in the cp structure. See the Description section for a discussion of how to determine the update status for any field.

**Description**

This procedure requests updates to fields in the CP table.

Updates to this table are not durable; that is, they do not survive a restart of the Remote Manager. To make nondynamic, permanent updates to the collection table, use the ACMSCFG utility.

Updates to the CP table are processed immediately and may affect more than one ACMS process.

## Example

```

int set_cp_data(int client_id,CLIENT *cl)
{
    cp_config_rec_2  set_struct;
    cp_status_rec_2 *ret_struct;
    dcl_link        *nl;

    memset(&set_struct,-1,sizeof(set_struct));

    set_struct.client_id      = client_id;
    set_struct.current_sw     = 1;
    set_struct.astlm          = 500;

    ret_struct = acmsmgmt_set_cp_2(&set_struct,cl);

    if (!ret_struct) {
        printf("\n Call to modify CP failed");
        return(MGMT_FAIL);
    }

    if (ret_struct->status != MGMT_SUCCESS)
        printf("\n Call to modify CP returned the following warnings or
        errors\n");
    else
        printf("\n Call to modify CP completed\n");

    for (nl = ret_struct->cp_status_rec_2_u.data.cmd_output; nl != NULL;
        nl = nl->pNext)
        printf("\n %s",nl->dcl_msg);
        xdr_free(xdr_cp_status_rec_2, ret_struct);
        free(ret_struct);
    return(0);
}

```

In the preceding example, the ACMSMGMT\_SET\_CP\_2 procedure is called. Otherwise, an error message is displayed.

## ACMSMGMT\_SET\_EXC\_2

ACMSMGMT\_SET\_EXC\_2 — This procedure modifies the ACMS Application Execution Controller (EXC) Config class attributes.

### Format

```
exc_status_rec_2 *acmsmgmt_set_exc_2(exc_config_rec_2 *set_struct,CLIENT *cl)
```

### Parameters

#### set\_struct

Type:	Exc_config_rec	
Access:	Read	
Mechanism:	By reference	



Usage:	Structure that contains the following client identification and EXC table fields.	
	<i>client_id</i>	
	Type:	Integer
	Access:	Read
	Mechanism:	By value
	Usage:	If explicit authentication is being used, a valid client ID must be provided. If the value of <i>client_id</i> is 0, proxy access is used. <i>Client_id</i> is obtained by calling the acms \$mgmt_get_creds procedure.
	<i>appl_name</i>	
	Type:	Null-terminated string
	Access:	Read
	Mechanism:	By reference
	Usage:	Name of the application to update.
	<i>audit_state, max_tasks, sp_mon_interval, max_servers, server_proc_dmpflag, transaction_timeout</i>	
	Type:	Integer
	Access:	Read
	Mechanism:	By value
	Usage:	Values to be updated. These fields correspond to the active fields of the same names in the EXC table (for example, <i>max_tasks</i> will update <i>max_tasks_active</i> ). See Section 9.6 for a discussion of these fields. All fields in this record can be updated dynamically. Stored values cannot be changed for EXCs (application must be rebuilt).

**cl**

Type:	CLIENT *
Access:	Read
Mechanism:	By value

Usage:	Pointer to an RPC client handle previously obtained by calling the RPC routine CLNT_CREATE.
--------	---

## Return Value

Type:	Struct exc_status_rec
Access:	Write
Mechanism:	By reference
Usage:	<p>Pointer to a union. The union contains either a failure code or a structure of type exc_config_rec_out, which contains status codes for each field, as well as a linked list of status messages associated with the update. See the Description section for a discussion of how to determine the update status for any field. The following are the contents of this union:</p>
<i>status</i>	
Type:	Integer
Access:	Write
Mechanism:	By value
Usage:	Failure return code.
<i>data, data_warn</i>	
Type:	Exc_config_rec_out
Access:	Write
Mechanism:	By value
Usage:	<p>Structure containing fields corresponding to the fields in the exc_config_rec structure, as well as a linked list of status messages associated with the update. See the Description section for a discussion of how to determine the update status for any field. The following are the contents of this structure:</p>
<i>audit_state, max_tasks, sp_mon_interval, max_servers, server_proc_dmpflag, transaction_timeout</i>	
Type:	Integer
Access:	Write
Mechanism:	By value
Usage:	Status fields corresponding to the fields in the input argument.
<i>cmd_output</i>	
Type:	Dcl_list
Access:	Write
Mechanism:	By reference

		Usage:	Pointer to a linked list of records containing status messages related to the failure of any updates. This structure contains the following fields:
			<i>dcl_msg</i>
		Type:	Null-terminated string
		Access:	Write
		Mechanism:	By reference
		Usage:	The status message.
			<i>pNext</i>
		Type:	Dcl_list
		Access:	Write
		Mechanism:	By reference
		Usage:	Pointer to the next node in the linked list.

## Description

This procedure requests updates to ACMS EXC Config class fields contained in the EXC table (see Section 9.6). Note that the EXC table contains both active and stored values; however, only the active fields can be changed. In order to change the stored values, the application must be rebuilt.

For any nonnegative integer fields, the completion status of the update is returned in the corresponding field in the return structure.

## Example

```
int set_exc_data(int client_id, CLIENT *cl)
{
    static char vr_appl[] = "VR_APPL";
    static exc_config_rec_2 set_struct;
    exc_status_rec_2      *ret_struct;
    dcl_link              *nl;

    memset(&set_struct, -1, sizeof(set_struct));
    set_struct.client_id   = client_id;
    set_struct.audit_state = MGMT_STATE_DISABLED;
    set_struct.appl_name   = vr_appl;

    ret_struct = acmsgmt_set_exc_2(&set_struct, cl);

    if (!ret_struct) {
        printf("\n Call to modify EXC failed");
        return(MGMT_FAIL);
    }
}
```

```

}

if (ret_struct->status != MGMT_SUCCESS)
    printf("\n Call to modify EXC returned the following warnings or
        errors\n");
else
    printf("\n Call to modify EXC completed\n");

for (nl = ret_struct->exc_status_rec_2_u.data.cmd_output; nl != NULL; nl
=
    nl->pNext)
    printf("\n %s",nl->dcl_msg);
    xdr_free(xdr_exc_status_rec_2, ret_struct);
    free(ret_struct);
return(0);
}

```

In the preceding example, the `acmsmgmt_set_exc_1` procedure is called to disable application auditing for the application `VR_APPL` on the target node. If the call succeeds, the `VR_APPL` no longer writes application auditing messages, and a success message is displayed. Otherwise, an error message is displayed. The example in Section 6.3.1 shows how to declare and initialize the input arguments to this procedure.

## ACMSMGMT\_SET\_INTERFACE\_1

`ACMSMGMT_SET_INTERFACE_1` — This procedure modifies the status of a Remote Manager interface. Either the SNMP or RPC interface can be modified. **Note:** ACMS Remote Manager will not allow the RPC interface to be `DISABLED` through this call. The only way to disable the RPC interface dynamically is to use the SNMP interface.

### Format

```
int *acmsmgmt_set_interface_1(interface_config_rec *if_cfg_rec,CLIENT *cl)
```

### Parameters

#### `if_cfg_rec`

Type:	Interface_config_rec		
Access:	Read		
Mechanism:	By reference		
Usage:	Structure that contains the following client identification and interface configuration fields.		
	<i>client_id</i>		
	Type:	Integer	
	Access:	Read	
	Mechanism:	By value	
	Usage:	If explicit authentication is being used, a valid client ID must be provided. If the	

	value for <code>client_id</code> is 0, proxy access is used. <code>Client_id</code> is obtained by calling the <code>acms \$mgmt_get_creds</code> procedure.
<i>interface_type</i>	
Type:	Integer
Access:	Read
Mechanism:	By value
Usage:	Indicates the interface to be modified. Table 8.2 shows the valid symbolic values for interface types.
<i>state</i>	
Type:	Integer
Access:	Read
Mechanism:	By value
Usage:	Indicates desired state of the interface. Table 8.3 shows the valid symbolic values for the allowable states.

**cl**

Type:	CLIENT *
Access:	Read
Mechanism:	By value
Usage:	Pointer to an RPC client handle previously obtained by calling the RPC routine <code>CLNT_CREATE</code> .

**Return Value**

Type:	Integer
Access:	Write
Mechanism:	By reference
Usage:	Pointer to status value returned. If <code>NULL</code> or <code>MGMT_SUCCESS</code> , the RPC has succeeded. If neither <code>NULL</code> nor <code>MGMT_SUCCESS</code> , the procedure call failed and the value pointed to is the reason for failure.

**Description**

This procedure modifies the status of an interface. Interfaces can be enabled (that is, requested to start) or disabled (that is, requested to stop) by setting the state field in `if_cfg_rec` to the appropriate value.

Note that it is not possible to use the RPC interface to enable the RPC interface. In order to use the RPC interface, it must already be enabled. In order to start the RPC interface, either use the SNMP interface, or use the ACMSCFG utility to configure the RPC interface to be enabled when the Remote Manager starts up.

It is also not possible to use this call to disable the RPC interface. The ACMS Remote Manager does not allow an interface to disable itself. The only way to disable the RPC interface dynamically is to use the SNMP interface.

## Example

```
int set_interface_data(int client_id,CLIENT *cl)
{
    static interface_config_rec set_struct;
    int *status;

    memset(&set_struct,-1,sizeof(set_struct));

    set_struct.client_id = client_id;
    set_struct.interface_type = MGMT_IF_SNMP;
    set_struct.state = MGMT_STATE_ENABLED;

    status = acmsgmt_set_interface_1(&set_struct,cl);

    if (!status) {
        printf("\n Call to update SNMP interface failed");
        return(MGMT_FAIL);
    }

    if (*status != MGMT_SUCCESS) {
        printf("\n Call to update SNMP interface failed with status
%d",*status);
        free(status);
        return(MGMT_FAIL);
    }
    else
        printf("\n Call to set SNMP interface completed");
        free(status);
    return(0);
}
```

In the preceding example, the `acmsgmt_set_interface_1` procedure is called to enable the SNMP interface. If the call succeeds, the SNMP interface is running on the target node, and a success message is displayed. Otherwise, an error message is displayed. The example in Section 6.3.1 shows how to declare and initialize the input arguments to this procedure.

## ACMSMGMT\_SET\_PARAM\_2

`ACMSMGMT_SET_PARAM_2` — This procedure requests updates to fields in the Remote Manager Parameter table.

### Format

```
param_status_rec2 *acmsgmt_set_param_2(param_config_rec2 *set_struct,CLIENT *cl)
```

## Parameters

### set\_struct

Type:	Param_config_rec	
Access:	Read	
Mechanism:	By reference	
Usage:	Structure that contains the following client identification and parameter configuration fields.	
	<i>client_id</i>	
	Type:	Integer
	Access:	Read
	Mechanism:	By value
	Usage:	If explicit authentication is being used, a valid client ID must be provided. If the value for <i>client_id</i> is 0, proxy access is used. <i>Client_id</i> is obtained by calling the acms \$mgmt_get_creds procedure.
	<i>params</i>	
	Type:	Struct param_rec
	Access:	Read
	Mechanism:	By value
	Usage:	Structure containing a Parameter table record. Parameter table fields are described in Section 9.9. See the Description section for information on how to initialize this record.

### cl

Type:	CLIENT *
Access:	Read
Mechanism:	By value
Usage:	Pointer to an RPC client handle previously obtained by calling the RPC routine CLNT_CREATE.

## Return Value

Type:	Struct param_status_rec
Access:	write
Mechanism:	By reference

Usage:	Pointer to a union. The union either contains a failure code or a structure of type <code>param_rec</code> , which contains status codes for each field. See the Description section for a discussion of how to determine the update status for any field. The following are the contents of this union:	
	<i>status</i>	
Type:	Integer	
Access:	write	
Mechanism:	By value	
Usage:	Failure return code.	
	<i>data, data_warn</i>	
Type:	Param_rec	
Access:	write	
Mechanism:	By value	
Usage:	Structure containing a Parameter table record. The entries in this field contain status codes correspond to the fields in the <code>params</code> structure. See the Description section for a discussion of how to determine the update status for any field.	

## Description

This procedure requests updates to fields in the Parameter table (see Section 9.9). Some field updates are dynamic; others are not. Updates to this table are not durable; that is, they do not survive a restart of the Remote Manager.

When this procedure is called, any fields with negative values are ignored. Callers should initialize any fields to a negative value, for example, -1, for which updates are not to be applied. All nonnegative fields are validated prior to being updated.

For any nonnegative fields, the completion status of the update is returned in the corresponding field in the return structure. For instance, if the `mss_coll_interval` and `max_logins` fields in the `params` structure of the `param_config_rec` are nonnegative when this procedure is called, the `mss_coll_interval` and `max_logins` field of the `data` or `data_warn` structures of the `param_status_rec` will contain the completion status for those updates.

The `data` and `data_warn` structures contain identical data. If the operation fails, the status field of either structure is `MGMT_WARN`; in this case, use the `data_warn` structure to fetch the status messages from the `cmd_output` linked list.

If the operation is successful, the status field of either structure is `MGMT_SUCCESS`. There are no status messages associated with a successful call.

If the status field contains `MGMT_FAIL`, the call failed. There are no status messages returned; instead, the reason for the failure is contained in the `rc` field.



## Example

```

int set_param_data(int client_id,CLIENT *cl)
{
    static param_config_rec2 set_struct;
    param_status_rec2 *ret_struct;
    int status;

    memset(&set_struct,-1,sizeof(set_struct));

    set_struct.client_id = client_id;
    set_struct.params.max_logins = 25;

    ret_struct = acmsmgmt_set_param_2(&set_struct,cl);

    if (!ret_struct) {
        printf("\n Call to modify parameters failed");
        return(MGMT_FAIL);
    }

    if (ret_struct->status != MGMT_SUCCESS) {

        if (ret_struct->status != MGMT_WARN) {
            printf("\nCall to modify parameters failed, returning %d",
                ret_struct->status);
            status = ret_struct->status;
            xdr_free(xdr_param_status_rec2, ret_struct);
            free(ret_struct);
            return(MGMT_FAIL);
        }

        if (ret_struct->param_status_rec2_u.data.max_logins != MGMT_SUCCESS)
            printf("\n max_logins specified was invalid ");
            xdr_free(xdr_param_status_rec2, ret_struct);
            free(ret_struct);
            return(MGMT_FAIL);
        }

        else
            printf("\n Call to set params completed");
            xdr_free(xdr_param_status_rec2, ret_struct);
            free(ret_struct);
            return(0);
    }
}

```

In the preceding example, the `acmsmgmt_set_param_1` procedure is called to set the maximum number of logins to the Remote Manager to 25. If the call succeeds, the new value will be stored in the Parameter table and a success message will be displayed. Otherwise, an error message is displayed. The example in Section 6.3.1 shows how to declare and initialize the input arguments to this procedure.

## ACMSMGMT\_SET\_QTI\_2

`ACMSMGMT_SET_QTI_2` — This procedure modifies Queued Task Initiator (QTI) Config class attributes.

## Format

```
qti_status_rec_2 *acmsmgmt_set_qti_2(qti_config_rec_2 *set_struct,CLIENT *cl)
```

## Parameters

### set\_struct

Type:	Qti_config_rec		
Access:	Read		
Mechanism:	By reference		
Usage:	Structure that contains the following client identification and QTI table fields.		
	<i>client_id</i>		
	Type:	Integer	
	Access:	Read	
	Mechanism:	By value	
	Usage:	If explicit authentication is being used, a valid client ID must be provided. If the value of <i>client_id</i> is 0, proxy access is used. <i>Client_id</i> is obtained by calling the <i>acms \$mgmt_get_creds</i> procedure.	
	<i>active_sw</i>		
	Type:	Integer	
	Access:	Read	
	Mechanism:	By value	
	Usage:	Indicates whether active variables should be updated ( <i>active_sw</i> = 1). Active variables are currently in use by the ACMS system; updates to active variables take effect immediately but are not durable (that is, they do not survive a restart of the ACMS system). Not all variables are dynamic, however. Refer to Section 9.10 and to the field descriptions in this section, to determine whether a particular variable can be updated dynamically.	
	<i>current_sw</i>		

Type:	Integer
Access:	Read
Mechanism:	By value
Usage:	Indicates whether current variables should be updated ( <code>current_sw = 1</code> ). Current variables are those stored in the ACMSGEN file currently in use by the ACMS system and are durable (that is, they survive a restart of the ACMS system). Updates to current variables take effect when the ACMS system is restarted.
<i>qti_priority, max_threads, sub_timeout, retry_timer, polling_timer</i>	
Type:	Integer
Access:	Read
Mechanism:	By value
Usage:	Values to be updated. These fields correspond to fields of the same names in the QTI table, depending on the value of <code>active_sw</code> and <code>current_sw</code> in this record (for example, <code>qti_priority</code> will update the <code>qti_priority_stored</code> field if <code>current_sw</code> is equal to 1). See Section 9.10 for a discussion of these fields. Note that not all fields can be updated dynamically.
<i>qti_username</i>	
Type:	Null-terminated string
Access:	Read
Mechanism:	By reference
Usage:	Values to be updated. This field corresponds to the <code>qti_username</code> field in the QTI table; the exact field depends on the value of <code>active_sw</code> and <code>current_sw</code> in this record (for example, <code>qti_username</code> will update the <code>qti_username_stored</code> field if <code>current_sw</code> is equal to 1). See Section 9.10 for a discussion

	of these fields. Note that not all fields can be updated dynamically. In order to have this field set to null (that is, ""), set the field to the string "NULL".
--	--

**cl**

Type:	CLIENT *
Access:	Read
Mechanism:	By value
Usage:	Pointer to an RPC client handle previously obtained by calling the RPC routine CLNT_CREATE.

**Return Value**

Type:	Struct qti_status_rec	
Access:	Write	
Mechanism:	By reference	
Usage:	<p>Pointer to a union. The union contains either a failure code or a structure of type qti_config_rec_out, which contains status codes for each field, as well as a linked list of status messages associated with the update. See the Description section for a discussion of how to determine the update status for any field. The following are the contents of this union:</p>	
	<i>status</i>	
	Type:	Integer
	Access:	Write
	Mechanism:	By value
	Usage:	Failure return code.
	<i>data, data_warn</i>	
	Type:	Qti_config_rec_out
	Access:	Write
	Mechanism:	By value
	Usage:	Structure containing fields corresponding to the fields in the qti_config_rec structure, as well as a linked list of status messages associated with the update. See the Description section for a discussion of how to determine the update status for any field. The following are the contents of this structure:
	<i>qti_priority, max_threads, sub_timeout, retry_timer, polling_timer</i>	
	Type:	Integer

	Access:	Write
	Mechanism:	By value
	Usage:	Status fields corresponding to the fields in the input argument.
	<i>qti_username</i>	
	Type:	Null-terminated string
	Access:	Write
	Mechanism:	By reference
	Usage:	This field contains the value that was supplied in the input argument and can be ignored.
	<i>cmd_output</i>	
	Type:	Dcl_list
	Access:	Write
	Mechanism:	By reference
	Usage:	Pointer to a linked list of records containing status messages related to the failure of any updates. This structure contains the following fields:
	<i>dcl_msg</i>	
	Type:	Null-terminated string
	Access:	Write
	Mechanism:	By reference
	Usage:	The status message.
	<i>pNext</i>	
	Type:	Dcl_list
	Access:	Write
	Mechanism:	By reference
	Usage:	Pointer to the next node in the linked list.

## Description

This procedure requests updates to ACMS QTI Config class fields contained in the QTI table (see Section 9.10). Note that the QTI table contains both active and stored values. The `active_sw` field and `current_sw` field control which fields should be updated.

Attempting to update an active field that is nondynamic is essentially useless, since the active field value does not change. For instance, calling this procedure with the `active_sw` field set to 1 and the `qti_username` field populated produces no change to the system.

Setting the `current_sw` field to 1 causes updates to be written to the current ACMSGEN file. These updates are durable, that is, they survive a restart of the ACMS system, but do not affect the active system until the system is restarted.

Both `current_sw` and `active_sw` can be set on a given call. In this case, both the active and stored values for any nonnegative or nonnull fields are updated.

For any nonnegative integer fields, the completion status of the update is returned in the corresponding field in the return structure. For string fields, the string field value is returned, regardless of the status of the call.

In order to have one of the string fields set to a null string, that is, "", populate the field with value "NULL". To have one of the string fields ignored, pass in a null string.

## Example

```
int set_qti_data(int client_id, CLIENT *cl)
{
    static char c_name_all[2] = "*";
    static char c_null_str[2] = "";
    static qti_config_rec_2 set_struct;
    qti_status_rec_2      *ret_struct;
    dcl_link              *nl;

    memset(&set_struct, -1, sizeof(set_struct));
    set_struct.client_id   = client_id;
    set_struct.active_sw  = 1;
    set_struct.current_sw = 0;
    set_struct.polling_timer = 4999;

    /* Have to provide a pointer for string conversions by XDR
       or it will qtiess vio. RM will ignore any fields with
       strlen of 0 */
    set_struct.qti_username = c_null_str;

    ret_struct = acmsgmt_set_qti_2(&set_struct, cl);

    if (!ret_struct) {
        printf("\n Call to modify qti failed");
        return(MGMT_FAIL);
    }

    if (ret_struct->status != MGMT_SUCCESS)
        printf("\n Call to modify QTI returned the following warnings or
            errors\n");
    else
        printf("\n Call to modify QTI completed\n");

    for (nl = ret_struct->qti_status_rec_2_u.data.cmd_output; nl != NULL;
         nl = nl->pNext)
        printf("\n %s", nl->dcl_msg);
    xdr_free(xdr_qti_status_rec_2, ret_struct);
    free(ret_struct);
}
```

```

    return(0);
}

```

In the preceding example, the `acmsmgmt_set_qti_1` procedure is called to set the ACMSGEN parameter `qti_polling_timer` to 4999 milliseconds. If the call succeeds, only the active value is modified, the stored value is unchanged, and a success message is displayed. Otherwise, an error message is displayed. The example in Section 6.3.1 shows how to declare and initialize the input arguments to this procedure.

## ACMSMGMT\_SET\_SERVER\_1

`ACMSMGMT_SET_SERVER_1` — This procedure modifies server (ACMS procedure server) Config class attributes.

### Format

`ser_status_rec *acmsmgmt_set_server_1(ser_config_rec *set_struct, CLIENT *cl)`

### Parameters

#### set\_struct

Type:	Ser_config_rec	
Access:	Read	
Mechanism:	By reference	
Usage:	Structure that contains the following client identification and Server table fields.	
	<i>client_id</i>	
	Type:	Integer
	Access:	Read
	Mechanism:	By value
	Usage:	If explicit authentication is being used, a valid client ID must be provided. If the value of <code>client_id</code> is 0, proxy access is used. <code>Client_id</code> is obtained by calling the <code>acms \$mgmt_get_creds</code> procedure.
	<i>appl_name</i>	
	Type:	Null-terminated string
	Access:	Read
	Mechanism:	By reference
	Usage:	Name of the application to which the server to be updated belongs.

<i>server_name</i>	
Type:	Null-terminated string
Access:	Read
Mechanism:	By reference
Usage:	Name of the server to update.
<i>creation_delay, creation_interval, deletion_delay, deletion_interval, server_proc_dmpflag, minimum_instances, maximum_instances</i>	
Type:	Integer
Access:	Read
Mechanism:	By value
Usage:	Values to be updated. These fields correspond to the active fields of the same names in the Server table (for example, <i>creation_delay</i> updates the <i>creation_delay_active</i> field). See Section 9.11 for a discussion of these fields. All fields in this record can be updated dynamically.

**cl**

Type:	CLIENT *
Access:	Read
Mechanism:	By value
Usage:	Pointer to an RPC client handle previously obtained by calling the RPC routine CLNT_CREATE.

**Return Value**

Type:	Struct <i>ser_status_rec</i>
Access:	Write
Mechanism:	By reference
Usage:	Pointer to a union. The union contains either a failure code or a structure of type <i>ser_config_rec_out</i> , which contains status codes for each field, as well as a linked list of status messages associated with the update. See the Description section for a discussion of how to determine the update status for any field. The following are the contents of this union:
<i>status</i>	
Type:	Integer
Access:	Write
Mechanism:	By value



Usage:	Failure return code.
<i>data, data_warn</i>	
Type:	Ser_config_rec_out
Access:	Write
Mechanism:	By value
Usage:	Structure containing fields corresponding to the fields in the ser_config_rec structure, as well as a linked list of status messages associated with the update. See the Description section for a discussion of how to determine the update status for any field. The following are the contents of this structure:
<i>creation_delay, creation_interval, deletion_delay, deletion_interval, server_proc_dmpflag, minimum_instances, maximum_instances</i>	
Type:	Integer
Access:	Write
Mechanism:	By value
Usage:	Status fields corresponding to the fields in the input argument.
<i>cmd_output</i>	
Type:	Dcl_list
Access:	Write
Mechanism:	By reference
Usage:	Pointer to a linked list of records containing status messages related to the failure of any updates. This structure contains the following fields:
<i>dcl_msg</i>	
Type:	Null-terminated string
Access:	Write
Mechanism:	By reference
Usage:	The status message.
<i>pNext</i>	
Type:	Dcl_list
Access:	Write

			Mechanism:	By reference
			Usage:	Pointer to the next node in the linked list.

## Description

This procedure requests updates to ACMS server Config class fields contained in the Server table (see Section 9.11). Note that the Server table contains only active values.

For any nonnegative integer fields, the completion status of the update is returned in the corresponding field in the return structure.

## Example

```
int set_ser_data(int client_id, CLIENT *cl)
{
    static char c_name_all[2] = "*";
    static char vr_appl[] = "VR_APPL";
    static ser_config_rec set_struct;
    ser_status_rec      *ret_struct;
    dcl_link            *nl;

    memset(&set_struct, -1, sizeof(set_struct));
    set_struct.client_id      = client_id;
    set_struct.appl_name      = vr_appl;
    set_struct.server_name    = c_name_all;
    set_struct.creation_delay = 20;

    ret_struct = acmsgmt_set_server_1(&set_struct, cl);

    if (!ret_struct) {
        printf("\n Call to modify Server failed");
        return(MGMT_FAIL);
    }

    if (ret_struct->status != MGMT_SUCCESS)
        printf("\n Call to modify Server returned the following warnings or
            errors\n");
    else
        printf("\n Call to modify Server completed\n");

    for (nl = ret_struct->ser_status_rec_u.data.cmd_output; nl != NULL;
         nl = nl->pNext)
        printf("\n %s", nl->dcl_msg);
        xdr_free(xdr_ser_status_rec, ret_struct);
        free(ret_struct);
    return(0);
}
```

In the preceding example, the `acmsgmt_set_server_1` procedure is called to set the `creation_delay` parameter field for all servers in application `VR_APPL` to 20 seconds. If the call succeeds, this parameter field is modified for all servers in the `VR_APPL`, and a success message is displayed. Otherwise, an error message is displayed. The example in Section 6.3.1 shows how to declare and initialize the input arguments to this procedure.

## ACMSMGMT\_SET\_TRAP\_1

ACMSMGMT\_SET\_TRAP\_1 — This procedure modifies entries in the Remote Manager Trap table. Trap table entries can also be added and deleted.

### Format

```
trap_status_rec *acmsmgmt_set_trap_1(trap_config_rec *set_struct, CLIENT *cl)
```

### Parameters

#### set\_struct

Type:	Trap_config_rec	
Access:	Read	
Mechanism:	By reference	
Usage:	Structure that contains the following client identification and Trap table fields.	
	<i>client_id</i>	
	Type:	Integer
	Access:	Read
	Mechanism:	By value
	Usage:	If explicit authentication is being used, a valid client ID must be provided. If the value of <i>client_id</i> is 0, proxy access is used. <i>Client_id</i> is obtained by calling the <code>acms\$mgmt_get_creds</code> procedure.
	<i>trap_entry</i>	
	Type:	Struct trap_update_rec_r
	Access:	Read
	Mechanism:	By value
	Usage:	Structure containing a Trap table record. Trap table fields are described in Section 9.13. See the Description section for information on how to initialize this record.

#### cl

Type:	CLIENT *
-------	----------

Access:	Read
Mechanism:	By value
Usage:	Pointer to an RPC client handle previously obtained by calling the RPC routine CLNT_CREATE.

## Return Value

Type:	Struct trap_status_rec	
Access:	Write	
Mechanism:	By reference	
Usage:	Pointer to a union. The union contains either a failure code or a structure of type trap_update_rec_r, which contains status codes for each field. See the Description section for a discussion of how to determine the update status for any field. The following are the contents of this union:	
	<i>status</i>	
	Type:	Integer
	Access:	Write
	Mechanism:	By value
	Usage:	Failure return code.
	<i>data_warn</i>	
	Type:	Trap_update_rec_r
	Access:	Write
	Mechanism:	By value
	Usage:	Structure containing a Trap table record. The entries in this field contain status codes corresponding to the fields in the trap_entry structure. See the Description section for a discussion of how to determine the update status for any field.

## Description

This procedure requests updates to fields in the Trap table (see Section 9.13).

Updates to this table are not durable; that is, they do not survive a restart of the Remote Manager. To make nondynamic, permanent updates to the Trap table, use the ACMSCFG utility.

Calls to this procedure must specify `entity_type`, `entity_name`, and `param_to_trap`. These fields must exactly match an existing record in the Trap table for the update to be applied. Table 8.1 and Table 8.4 contain symbolic values used to populate the `collection_class` and `entity_type` fields; symbolic values to the `param_to_trap` field are described in Table 8.8.

Setting fields `trap_min`, `trap_max`, or `severity` to `-2` excludes them from being updating. Otherwise, the corresponding field in the matching trap record is modified. `-1` is a special value that causes the field to be ignored when evaluating the trap conditions; see Section 7.8.

Updates to the Trap table are processed immediately and may affect more than one ACMS process. See Section 7.8 for a discussion of how to set SNMP traps.

## Example

```
int set_trap_data(int client_id, CLIENT *cl)
{
    static char c_name_all[2] = "*";
    static trap_config_rec set_struct;
    struct trap_status_rec *status_rec;

    set_struct.client_id           = client_id
    set_struct.trap_entry.entity_type = MGMT_ACC;
    set_struct.trap_entry.entity_name = c_name_all;
    set_struct.trap_entry.param_to_trap = MGMT_EXISTS;
    set_struct.trap_entry.min         = 1;
    set_struct.trap_entry.max         = -1;
    set_struct.trap_entry.severity    = MGMT_SEV_FATAL;

    status_rec = acmsmgmt_set_trap_1(&set_struct, cl);

    if (!status_rec) {
        printf("\n Call to modify trap failed");
        return(MGMT_FAIL);
    }

    if (status_rec->status == MGMT_WARN) {
        printf("\nThe following updates failed: ");
        if (status_rec->trap_status_rec_u.data_warn.entity_type ==
MGMT_FAIL)
            printf("\n    entity_type not found or invalid");
        if (status_rec->trap_status_rec_u.data_warn.param_to_trap ==
MGMT_FAIL)
            printf("\n    param not found or invalid");
        if (status_rec->trap_status_rec_u.data_warn.min == MGMT_FAIL)
            printf("\n    min invalid");
        if (status_rec->trap_status_rec_u.data_warn.max == MGMT_FAIL)
            printf("\n    max invalid");
        if (status_rec->trap_status_rec_u.data_warn.severity == MGMT_FAIL)
            printf("\n    severity invalid");
    }

    else if (status_rec->status != MGMT_SUCCESS) {
        printf("\nCall to modify trap failed with status %d",
            status_rec->trap_status_rec_u.rc);
        xdr_free(xdr_trap_status_rec, status_rec);
        free(status_rec);
        return(MGMT_FAIL);
    }
    else
        printf("\nCall to modify trap was executed");
        xdr_free(xdr_trap_status_rec, status_rec);
        free(status_rec);
}
```

```

    return(0);
}

```

In the preceding example, the `acmsmgmt_set_trap_1` procedure is called to set the `trap_min` field to 1, the `trap_max` field to -1, and the trap severity to FATAL for a trap based on an `entity_type` of ACC, an `entity_name` of \* (all), and a trap parameter of EXISTS. The effect of this change is to cause a fatal-level trap to be generated if the ACC on the target node is stopped. If the call succeeds, the trap is reconfigured in the Trap table in memory. Otherwise, an error message is displayed. The example in Section 6.3.1 shows how to declare and initialize the input arguments to this procedure.

## ACMSMGMT\_SET\_TSC\_2

`ACMSMGMT_SET_TSC_2` — This procedure modifies Terminal Subsystem Controller (TSC) Config class attributes.

### Format

```
tsc_status_rec_2 *acmsmgmt_set_tsc_2(tsc_config_rec_2 *set_struct, CLIENT *cl)
```

### Parameters

#### set\_struct

Type:	Tsc_config_rec	
Access:	Read	
Mechanism:	By reference	
Usage:	Structure that contains the following client identification and TSC table fields.	
	<i>client_id</i>	
	Type:	Integer
	Access:	Read
	Mechanism:	By value
	Usage:	If explicit authentication is being used, a valid client ID must be provided. If the value of <code>client_id</code> is 0, proxy access is used. <code>Client_id</code> is obtained by calling the <code>acmsmgmt_get_creds</code> procedure.
	<i>active_sw</i>	
	Type:	Integer
	Access:	Read
	Mechanism:	By value
	Usage:	Indicates whether active variables should be updated ( <code>active_sw = 1</code> ). Active variables

	are currently in use by the ACMS system; updates to active variables take effect immediately but are not durable (that is, they do not survive a restart of the ACMS system). Not all variables are dynamic, however. Refer to Section 9.15, and to the field descriptions in this section, to determine whether a particular variable can be updated dynamically.
<i>current_sw</i>	
Type:	Integer
Access:	Read
Mechanism:	By value
Usage:	Indicates whether current variables should be updated ( <i>current_sw</i> = 1). Current variables are those stored in the ACMSGEN file currently in use by the ACMS system and are durable (that is, they survive a restart of the ACMS system). Updates to current variables take effect when the ACMS system is restarted.
<i>tsc_priority, cp_priority, cp_slots, max_logins, max_tts_cp, perm_cps, min_cpis</i>	
Type:	Integer
Access:	Read
Mechanism:	By value
Usage:	Values to be updated. These fields correspond to fields of the same names in the TSC table, depending on the value of <i>active_sw</i> and <i>current_sw</i> in this record (for example, <i>tsc_priority</i> will update the <i>tsc_priority_stored</i> field if <i>current_sw</i> is equal to 1). See Section 9.15 for a discussion of these fields. Note that not all fields can be updated dynamically.

<i>tsc_username, cp_username</i>	
Type:	Null-terminated string
Access:	Read
Mechanism:	By reference
Usage:	Values to be updated. These fields correspond to fields of the same names in the TSC table, depending on the value of <i>active_sw</i> and <i>current_sw</i> in this record (for example, <i>tsc_username</i> will update the <i>tsc_username_stored</i> field if <i>current_sw</i> is equal to 1). See Section 9.15 for a discussion of these fields. Note that not all fields can be updated dynamically. In order to have any of these fields set to null (that is, ""), set the field to the string "NULL".

**cl**

Type:	CLIENT *
Access:	Read
Mechanism:	By value
Usage:	Pointer to an RPC client handle previously obtained by calling the RPC routine <i>CLNT_CREATE</i> .

**Return Value**

Type:	Struct <i>tsc_status_rec</i>	
Access:	Write	
Mechanism:	By reference	
Usage:	Pointer to a union. The union contains either a failure code or a structure of type <i>tsc_config_rec_out</i> , which contains status codes for each field, as well as a linked list of status messages associated with the update. See the Description section for a discussion of how to determine the update status for any field. The following are the contents of this union:	
	<i>status</i>	
	Type:	Integer
	Access:	Write
	Mechanism:	By value
	Usage:	Failure return code.
	<i>data, data_warn</i>	



Type:	Tsc_config_rec_out	
Access:	Write	
Mechanism:	By value	
Usage:	Structure containing fields corresponding to the fields in the <code>acc_config_rec</code> structure, as well as a linked list of status messages associated with the update. See the Description section for a discussion of how to determine the update status for any field. The following are the contents of this structure:	
	<i>tsc_priority, cp_priority, cp_slots, max_logins, max_tts_cp, perm_cps, min_cpis</i>	
Type:	Integer	
Access:	Write	
Mechanism:	By value	
Usage:	Status fields corresponding to the fields in the input argument.	
	<i>tsc_username, cp_username</i>	
Type:	Null-terminated string	
Access:	Write	
Mechanism:	By reference	
Usage:	These fields contain the values that were supplied in the input argument, and can be ignored.	
	<i>cmd_output</i>	
Type:	Dcl_list	
Access:	Write	
Mechanism:	By reference	
Usage:	Pointer to a linked list of records containing status messages related to the failure of any updates. This structure contains the following fields:	
	<i>dcl_msg</i>	
Type:	Null-terminated string	
Access:	Write	
Mechanism:	By reference	
Usage:	The status message.	

			<i>pNext</i>
		Type:	Dcl_list
		Access:	Write
		Mechanism:	By reference
		Usage:	Pointer to the next node in the linked list.

## Description

This procedure requests updates to ACMS TSC Config class fields contained in the TSC table (see Section 9.15). Note that the TSC table contains both active and stored values. The `active_sw` field and `current_sw` field control which fields are attempted to be updated.

Attempting to update an active field that is nondynamic is essentially useless, since the active field value will not change. For instance, calling this procedure with the `active_sw` field set to 1 and the `tsc_username` field populated does not result in any change to the system.

Setting the `current_sw` field to 1 causes updates to be written to the current ACMSGEN file. These updates are durable, that is, they survive a restart of the ACMS system, but do not affect the active system until the system is restarted.

Both `current_sw` and `active_sw` may be set on a given call. In this case, both the active and stored values for any nonnegative or nonnull fields will be updated.

For any nonnegative integer fields, the completion status of the update is returned in the corresponding field in the return structure. For string fields, the string field value is returned, regardless of the status of the call.

In order to have one of the string fields set to a null string, that is, "", populate the field with value "NULL". To have one of the string fields ignored, pass in a null string.

## Example

```
int set_tsc_data(int client_id, CLIENT *cl)
{
    static char c_name_all[2] = "*";
    static char c_null_str[2] = "";
    static tsc_config_rec set_struct;
    tsc_status_rec      *ret_struct;
    dcl_link            *nl;

    memset(&set_struct, -1, sizeof(set_struct));

    set_struct.client_id      = client_id;
    set_struct.active_sw     = 1;
    set_struct.current_sw    = 0;
    set_struct.max_logins    = 61;

    /* Have to provide a pointer for string conversions by XDR
```

```

    or it will tscsess vio. RM will ignore any fields with
    strlen of 0 */
    set_struct.tsc_username = c_null_str;
    set_struct.cp_username  = c_null_str;

    ret_struct = acmsmgmt_set_tsc_2(&set_struct,cl);

    if (!ret_struct) {
        printf("\n Call to modify TSC failed");
        return(MGMT_FAIL);
    }

    if (ret_struct->status != MGMT_SUCCESS)
        printf("\n Call to modify TSC returned the following warnings or
        errors\n");
    else
        printf("\n Call to modify TSC completed\n");
    for (nl = ret_struct->tsc_status_rec_2_u.data.cmd_output; nl != NULL;
        nl = nl->pNext)
        printf("\n %s",nl->dcl_msg);
        xdr_free(xdr_tsc_status_rec_2, ret_struct);
        free(ret_struct);
    return(0);
}

```

In the preceding example, the `acmsmgmt_set_tsc_1` procedure is called to set the `ACMSGEN` parameter `max_logins` to 61. If the call succeeds, only the active value is modified; the stored value is unchanged, and a success message is displayed. Otherwise, an error message is displayed. The example in Section 6.3.1 shows how to declare and initialize the input arguments to this procedure

## ACMSMGMT\_START\_ACC\_1

`ACMSMGMT_START_ACC_1` — This procedure requests that the Remote Manager start the ACMS system.

### Format

`cmd_output_rec *acmsmgmt_start_acc_1(acc_startup_rec *start_struct,CLIENT *cl)`

### Parameters

#### `start_struct`

Type:	Acc_startup_rec	
Access:	Read	
Mechanism:	By reference	
Usage:	Structure that contains the following client identification and Trap table fields.	
	<i>client_id</i>	
	Type:	Integer

Access:	Read
Mechanism:	By value
Usage:	If explicit authentication is being used, a valid client ID must be provided. If the value for <code>client_id</code> is 0, proxy access is used. <code>Client_id</code> is obtained by calling the <code>acms \$mgmt_get_creds</code> procedure.
<i>audit_sw</i>	
Type:	Integer
Access:	Read
Mechanism:	By value
Usage:	Indicates whether system auditing should be enabled ( <code>audit_sw = 1</code> ), or disabled ( <code>audit_sw = 0</code> ).
<i>qti_sw</i>	
Type:	Integer
Access:	Read
Mechanism:	By value
Usage:	Indicates whether the Queued Task Initiator (QTI) should be started ( <code>qti_sw = 1</code> ), or not ( <code>qti_sw = 0</code> ).
<i>terminals_sw</i>	
Type:	Integer
Access:	Read
Mechanism:	By value
Usage:	Indicates whether the Terminal Subsystem Controller (TSC) should be started ( <code>terminals_sw = 1</code> ), or not ( <code>terminals_sw = 0</code> ).

**cl**

Type:	CLIENT *
Access:	Read
Mechanism:	By value
Usage:	Pointer to an RPC client handle previously obtained by calling the RPC routine <code>CLNT_CREATE</code> .

## Return Value

Type:	Cmd_output_rec	
Access:	Write	
Mechanism:	By reference	
Usage:	<p>Pointer to a union. The union contains either a failure code or a structure of type cmd_rec_r, which points to a linked list containing status messages. The following are the contents of this union:</p>	
	<i>status</i>	
Type:	Integer	
Access:	Write	
Mechanism:	By value	
Usage:	Failure return code.	
	<i>rc</i>	
Type:	Integer	
Access:	Write	
Mechanism:	By value	
Usage:	Failure return code.	
	<i>data, data_warn</i>	
Type:	Cmd_rec	
Access:	Write	
Mechanism:	By value	
Usage:	<p>Structure containing the first node in a linked list of status messages (type dcl_list). The following are the contents of this structure:</p>	
	<i>cmd_output</i>	
Type:	Dcl_list	
Access:	Write	
Mechanism:	By reference	
Usage:	<p>Pointer to a linked list of records containing status messages related to the failure of any updates. This structure contains the following fields:</p>	
	<i>dcl_msg</i>	
Type:	Null-terminated string	
Access:	Write	

			Mechanism:	By reference
			Usage:	The status message.
			<i>pNext</i>	
			Type:	Dcl_list
			Access:	Write
			Mechanism:	By reference
			Usage:	Pointer to the next node in the linked list.

## Description

This procedure requests startup of the ACMS run-time system on the same node that the Remote Manager is running on. Fields in the input argument determine how the ACMS system will be started (that is, with or without auditing, terminals or QTI).

This call executes synchronously. It does not return to the caller until the attempt to start the system is complete. Any messages associated with an unsuccessful start of the system are returned in the `cmd_output` linked list.

The `data` and `data_warn` structures contain identical data. If the operation fails, the status field of both structures will be `MGMT_WARN`; in this case, use the `data_warn` structure to fetch the status messages from the `cmd_output` linked list.

If the operation is successful, the status field of both structures will be `MGMT_SUCCESS`. There are no status messages associated with a successful call. If the status field contains `MGMT_FAIL`, the call failed. No status messages are returned; instead, the reason for the failure is contained in the `rc` field.

## Example

```
int start_acc(int client_id,CLIENT *cl)
{
    dcl_link    *nl;
    static acc_startup_rec start_struct;
    cmd_output_rec *ret_struct;

    start_struct.client_id = client_id;
    start_struct.audit_sw  = 1;
    start_struct.qti_sw   = 1;
    start_struct.terminals_sw = 1;

    ret_struct = acmsmgmt_start_acc_1(&start_struct,cl);

    if (!ret_struct) {
        printf("\n Call to start system failed");
        return(MGMT_FAIL);
    }

    if (ret_struct->status != MGMT_SUCCESS) {

        if (ret_struct->status != MGMT_WARN) {
```

```

        printf("\nCall to start ACMS system failed with status %d",
            ret_struct->status);
        xdr_free(xdr_cmd_output_rec, ret_struct);
        free(ret_struct);
        return(MGMT_FAIL);
    }

    printf("\n Call to start ACMS system completed with warnings or
        errors");

    for (nl = ret_struct->cmd_output_rec_u.data.cmd_output; nl != NULL;
        nl = nl->pNext)
        printf("\n %s",nl->dcl_msg);
        xdr_free(xdr_cmd_output_rec, ret_struct);
        free(ret_struct);
        return(MGMT_FAIL);
    }

    else {
        printf("\nCall to start ACMS system was executed");
        for (nl = ret_struct->cmd_output_rec_u.data.cmd_output; nl !=
NULL;
            nl = nl->pNext)
            printf("\n %s",nl->dcl_msg);
    }

    xdr_free(xdr_cmd_output_rec, ret_struct);
    free(ret_struct);
    return(0);
}

```

In the preceding example, the `acmsmgmt_start_acc_1` procedure is called to start the ACMS run-time system on the target node. The system is started with system auditing enabled, the QTI started, and terminals started. If the call succeeds, the ACMS run-time system is started on the target node. Otherwise, any error messages associated with the failure are displayed. The example in Section 6.3.1 shows how to declare and initialize the input arguments to this procedure.

## ACMSMGMT\_START\_EXC\_1

`ACMSMGMT_START_EXC_1` — This procedure requests that the Remote Manager start an ACMS application on the same node on which the Remote Manager is running.

### Format

`cmd_output_rec *acmsmgmt_start_exc_1(exc_startup_rec *start_struct,CLIENT *cl)`

### Parameters

#### `start_struct`

Type:	Exc_startup_rec
Access:	Read
Mechanism:	By reference
Usage:	Structure that contains the following client identification and Trap table fields.

<i>client_id</i>	
Type:	Integer
Access:	Read
Mechanism:	By value
Usage:	If explicit authentication is being used, a valid client ID must be provided. If the value for <i>client_id</i> is 0, proxy access is used. <i>Client_id</i> is obtained by calling the <i>acms \$mgmt_get_creds</i> procedure.
<i>appl_name</i>	
Type:	Null-terminated string
Access:	Read
Mechanism:	By reference
Usage:	Pointer to the application name of the application to be started.

**cl**

Type:	CLIENT *
Access:	Read
Mechanism:	By value
Usage:	Pointer to an RPC client handle previously obtained by calling the RPC routine <i>CLNT_CREATE</i> .

**Return Value**

Type:	Cmd_output_rec
Access:	Write
Mechanism:	By reference
Usage:	Pointer to a union. The union contains either a failure code or a structure of type <i>cmd_rec_r</i> , which points to a linked list containing status messages. The following are the contents of this union:
<i>status</i>	
Type:	Integer
Access:	Write
Mechanism:	By value
Usage:	Failure return code.



<i>rc</i>	
Type:	Integer
Access:	Write
Mechanism:	By value
Usage:	Failure return code.
<i>data, data_warn</i>	
Type:	Cmd_rec
Access:	Write
Mechanism:	By value
Usage:	Structure containing the first node in a linked list of status messages (type dcl_list). The following are the contents of this structure:
<i>cmd_output</i>	
Type:	Dcl_list
Access:	Write
Mechanism:	By reference
Usage:	Pointer to a linked list of records containing status messages related to the failure of any updates. This structure contains the following fields:
<i>dcl_msg</i>	
Type:	Null-terminated string
Access:	Write
Mechanism:	By reference
Usage:	The status message.
<i>pNext</i>	
Type:	Dcl_list
Access:	Write
Mechanism:	By reference
Usage:	Pointer to the next node in the linked list.

## Description

This procedure starts an ACMS application on the same node on which the Remote Manager is running. The `appl_name` field in the input record determines which application will be started.

This call executes synchronously. It does not return to the caller until the attempt to start the application is complete. Any messages associated with an unsuccessful start of the application are returned in the `cmd_output` linked list.

The `data` and `data_warn` structures contain identical data. If the operation fails, the `status` field of either structure will be `MGMT_WARN`; in this case, use the `data_warn` structure to fetch the status messages from the `cmd_output` linked list.

If the operation is successful, the `status` field of either structure will be `MGMT_SUCCESS`. No status messages are associated with a successful call.

If the `status` field contains `MGMT_FAIL`, the call failed. No status messages are returned; instead, the reason for the failure is contained in the `rc` field.

## Example

```
int start_exc(int client_id, CLIENT *cl)
{
    dcl_link      *nl;
    static char c_appl_name[] = "VR_APPL";
    static exc_startup_rec start_struct;
    cmd_output_rec *ret_struct;

    start_struct.client_id = client_id;
    start_struct.appl_name = c_appl_name;

    ret_struct = acmsgmt_start_exc_1(&start_struct, cl);

    if (!ret_struct) {
        printf("\n Call to start EXC failed");
        return(MGMT_FAIL);
    }

    if (ret_struct->status != MGMT_SUCCESS) {

        if (ret_struct->status != MGMT_WARN) {
            printf("\nCall to start ACMS EXC failed with status %d",
                ret_struct->status);
            xdr_free(xdr_cmd_output_rec, ret_struct);
            free(ret_struct);
            return(MGMT_FAIL);
        }

        printf("\n Call to start ACMS EXC completed with warnings or
errors");

        for (nl = ret_struct->cmd_output_rec_u.data.cmd_output; nl != NULL;
            nl = nl->pNext)
            printf("\n %s", nl->dcl_msg);
            xdr_free(xdr_cmd_output_rec, ret_struct);
            free(ret_struct);
            return(MGMT_FAIL);
    }

    else {
        printf("\nCall to start ACMS EXC was executed");
        for (nl = ret_struct->cmd_output_rec_u.data.cmd_output; nl !=
NULL;
```

```

        nl = nl->pNext)
        printf("\n %s",nl->dcl_msg);
    }
    xdr_free(xdr_cmd_output_rec, ret_struct);
    free(ret_struct);
return(0);
}

```

In the preceding example, the `acmsmgmt_start_exc_1` procedure is called to start an application named `VR_APPL` on the target node. If the call succeeds, the `VR_APPL` application is started on the target node. Otherwise, any error messages associated with the failure are displayed. The example in Section 6.3.1 shows how to declare and initialize the input arguments to this procedure.

## ACMSMGMT\_START\_QTI\_1

`ACMSMGMT_START_QTI_1` — This procedure requests that the Remote Manager start a Queued Task Initiator (QTI) on the same node on which the Remote Manager is running.

### Format

`cmd_output_rec *acmsmgmt_start_qti_1(sub_id_struct *sub_rec,CLIENT *cl)`

### Parameters

#### `sub_rec`

Type:	Sub_id_struct *	
Access:	Read	
Mechanism:	By reference	
Usage:	Structure that contains the following client authorization information.	
	<i>client_id</i>	
	Type:	Integer
	Access:	Read
	Mechanism:	By value
	Usage:	If explicit authentication is being used, a valid client ID must be provided. If the value for <code>client_id</code> is 0, proxy access is used. <code>Client_id</code> is obtained by calling the <code>acms \$mgmt_get_creds</code> procedure.

#### `cl`

Type:	CLIENT *
Access:	Read

Mechanism:	By value
Usage:	Pointer to an RPC client handle previously obtained by calling the RPC routine CLNT_CREATE.

## Return Value

Type:	Cmd_output_rec	
Access:	Write	
Mechanism:	By reference	
Usage:	Pointer to a union. The union contains either a failure code or a structure of type cmd_rec_r, which points to a linked list containing status messages. The following are the contents of this union:	
	<i>status</i>	
Type:	Integer	
Access:	Write	
Mechanism:	By value	
Usage:	Failure return code.	
	<i>rc</i>	
Type:	Integer	
Access:	Write	
Mechanism:	By value	
Usage:	Failure return code.	
	<i>data, data_warn</i>	
Type:	Cmd_rec	
Access:	Write	
Mechanism:	By value	
Usage:	Structure containing the first node in a linked list of status messages (type dcl_list). The following are the contents of this structure:	
	<i>cmd_output</i>	
Type:	Dcl_list	
Access:	Write	
Mechanism:	By reference	
Usage:	Pointer to a linked list of records containing status messages related to the failure of any updates. This structure contains the following fields:	

			<i>dcl_msg</i>
			Type: Null-terminated string
			Access: Write
			Mechanism: By reference
			Usage: The status message.
			<i>pNext</i>
			Type: Dcl_list
			Access: Write
			Mechanism: By reference
			Usage: Pointer to the next node in the linked list.

## Description

This procedure starts an ACMS QTI on the same node on which the Remote Manager is running.

This call executes synchronously. It does not return to the caller until the attempt to start the QTI is complete. Any messages associated with an unsuccessful start of the QTI are returned in the `cmd_output` linked list.

The `data` and `data_warn` structures contain identical data. If the operation fails, the status field of both structures will be `MGMT_WARN`; in this case, use the `data_warn` structure to fetch the status messages from the `cmd_output` linked list.

If the operation is successful, the status field of both structures will be `MGMT_SUCCESS`. No status messages are associated with a successful call.

If the status field contains `MGMT_FAIL`, the call failed. No status messages are returned; instead, the reason for the failure is contained in the `rc` field.

## Example

```
int start_qti(int client_id, CLIENT *cl)
{
    dcl_link    *nl;
    static struct sub_id_struct sub_rec;
    cmd_output_rec *ret_struct;

    sub_rec.client_id = client_id;

    ret_struct = acmsgmt_start_qti_1(&sub_rec, cl);

    if (!ret_struct) {
        printf("\n Call to start QTI failed");
        return(MGMT_FAIL);
    }
}
```

```

if (ret_struct->status != MGMT_SUCCESS) {
    if (ret_struct->status != MGMT_WARN) {
        printf("\nCall to start ACMS QTI failed with status %d",
            ret_struct->status);
        xdr_free(xdr_cmd_output_rec, ret_struct);
        free(ret_struct);
        return(MGMT_FAIL);
    }

    printf("\n Call to start ACMS QTI completed with warnings or
errors");

    for (nl = ret_struct->cmd_output_rec_u.data.cmd_output; nl != NULL;
        nl = nl->pNext)
        printf("\n %s",nl->dcl_msg);
        xdr_free(xdr_cmd_output_rec, ret_struct);
        free(ret_struct);
        return(MGMT_FAIL);
    }

else {
    printf("\nCall to start ACMS QTI was executed");
    for (nl = ret_struct->cmd_output_rec_u.data.cmd_output; nl != NULL;
        nl = nl->pNext)
        printf("\n %s",nl->dcl_msg);
    }

    xdr_free(xdr_cmd_output_rec, ret_struct);
    free(ret_struct);
    return(0);
}

```

In the preceding example, the `acmsmgmt_start_qti_1` procedure is called to start the Queued Task Initiator (QTI) on the target node. If the call succeeds, the QTI is started on the target node. Otherwise, any error messages associated with the failure are displayed. The example in Section 6.3.1 shows how to declare and initialize the input arguments to this procedure.

## ACMSMGMT\_START\_TRACE\_MONITOR\_1

`ACMSMGMT_START_TRACE_MONITOR_1` — This procedure requests that the Remote Manager start the `ACMS$TRACE_MONITOR` process. The `ACMS$TRACE_MONITOR` process is an intermediate process used by the Remote Manager to communicate with ACMS run-time processes to enable and disable collections.

### Format

```
int *acmsmgmt_start_trace_monitor_1(sub_id_struct *sub_rec,CLIENT *cl)
```

### Parameters

#### sub\_rec

Type:	Sub_id_struct
-------	---------------

Access:	Read	
Mechanism:	By reference	
Usage:	Structure that contains the following client authorization information.	
	<i>client_id</i>	
	Type:	Integer
	Access:	Read
	Mechanism:	By value
	Usage:	If explicit authentication is being used, a valid client ID must be provided. If the value for <i>client_id</i> is 0, proxy access is used. <i>Client_id</i> is obtained by calling the <code>acms \$mgmt_get_creds</code> procedure.

**cl**

Type:	CLIENT *
Access:	Read
Mechanism:	By value
Usage:	Pointer to an RPC client handle previously obtained by calling the RPC routine <code>CLNT_CREATE</code> .

**Return Value**

Type:	Integer
Access:	Write
Mechanism:	By reference
Usage:	Pointer to status value returned. If the value is NULL or <code>MGMT_SUCCESS</code> , the RPC has succeeded. If the value is neither NULL nor <code>MGMT_SUCCESS</code> , the call failed and the value pointed to is the reason for failure.

**Description**

This procedure requests that the Remote Manager start the `ACMS$TRACE_MONITOR` process on the target node. The `ACMS$TRACE_MONITOR` process is an intermediate process used by the Remote Manager to communicate with ACMS run-time processes to enable and disable collections.

In general, external entities do not require a startup and shutdown request of the trace monitor process. The Remote Manager starts the trace monitor during process initialization and stops it during process shutdown. Additionally, the Remote Manager starts the trace monitor anytime it is needed if it is not already started. Once started, the trace monitor continues to run until the Remote Manager shuts down.

After issuing the start command to the trace monitor, the Remote Manager waits for a period of up to `trace_start_wait_time`, a Parameter table parameter that is dynamic and expressed in seconds. If the trace monitor fails to start during that period, the Remote Manager returns an error to the caller.

## Example

```
int start_trace(int client_id,CLIENT *cl)
{
    int *status;
    static struct sub_id_struct sub_rec;

    sub_rec.client_id = client_id;

    status = acmsmgmt_start_trace_monitor_1(&sub_rec,cl);

    if (!status) {
        printf("\nStartup of Trace Monitor has failed");
        return(MGMT_FAIL);
    }

    if (*status != MGMT_SUCCESS) {
        printf("\nStartup of Trace Monitor has failed with return code %d",
            *status);
        return(*status);
    }

    printf("\nTrace Monitor has been started ");
    free(status);
    return(MGMT_SUCCESS);
}
```

In the preceding example, the `acmsmgmt_start_trace_monitor_1` procedure is called to start the `ACMS$TRACE_MON` process on the target node. If the call succeeds, the process is started. Otherwise, any error messages associated with the failure are displayed. The example in Section 6.3.1 shows how to declare and initialize the input arguments to this procedure.

## ACMSMGMT\_START\_TSC\_1

`ACMSMGMT_START_TSC_1` — This procedure requests that the Remote Manager start a Terminal Subsystem Controller (TSC) on the same node on which it is running.

### Format

```
cmd_output_rec *acmsmgmt_start_tsc_1(sub_id_struct *sub_rec,CLIENT *cl)
```

### Parameters

#### sub\_rec

Type:	Sub_id_struct *
Access:	Read
Mechanism:	By reference
Usage:	Structure that contains the following client authorization information.



	<i>client_id</i>
Type:	Integer
Access:	Read
Mechanism:	By value
Usage:	If explicit authentication is being used, a valid client ID must be provided. If the value for <i>client_id</i> is 0, proxy access is used. <i>Client_id</i> is obtained by calling the <i>acms \$mgmt_get_creds</i> procedure.

**cl**

Type:	CLIENT *
Access:	Read
Mechanism:	By value
Usage:	Pointer to an RPC client handle previously obtained by calling the RPC routine <i>CLNT_CREATE</i> .

**Return Value**

Type:	Cmd_output_rec
Access:	Write
Mechanism:	By reference
Usage:	Pointer to a union. The union contains either a failure code or a structure of type <i>cmd_rec_r</i> , which points to a linked list containing status messages. The following are the contents of this union:
	<i>status</i>
Type:	Integer
Access:	Write
Mechanism:	By value
Usage:	Failure return code.
	<i>rc</i>
Type:	Integer
Access:	Write
Mechanism:	By value
Usage:	Failure return code.
	<i>data, data_warn</i>
Type:	Cmd_rec

Access:	Write
Mechanism:	By value
Usage:	Structure containing the first node in a linked list of status messages (type <code>dcl_list</code> ). The following are the contents of this structure:
	<i>cmd_output</i>
Type:	Dcl_list
Access:	Write
Mechanism:	By reference
Usage:	Pointer to a linked list of records containing status messages related to the failure of any updates. This structure contains the following fields:
	<i>dcl_msg</i>
Type:	Null-terminated string
Access:	Write
Mechanism:	By reference
Usage:	The status message.
	<i>pNext</i>
Type:	Dcl_list
Access:	Write
Mechanism:	By reference
Usage:	Pointer to the next node in the linked list.

## Description

This procedure requests that an ACMS TSC be started on the same node on which the Remote Manager is running.

This call executes synchronously. It does not return to the caller until the attempt to start the TSC is complete. Any messages associated with an unsuccessful start of the TSC are returned in the `cmd_output` linked list.

The `data` and `data_warn` structures contain identical data. If the operation fails, the status field of both structures will be `MGMT_WARN`; in this case, use the `data_warn` structure to fetch the status messages from the `cmd_output` linked list.

If the operation is successful, the status field of both structures will be `MGMT_SUCCESS`. No status messages are associated with a successful call.

If the status field contains `MGMT_FAIL`, the call failed. No status messages are returned; instead, the reason for the failure is contained in the `rc` field.

## Example

```
int start_tsc(int client_id, CLIENT *cl)
{
    dcl_link      *nl;
    static struct sub_id_struct sub_rec;
    cmd_output_rec *ret_struct;

    sub_rec.client_id = client_id;

    ret_struct = acmsgmt_start_tsc_1(&sub_rec, cl);

    if (!ret_struct) {
        printf("\n Call to start TSC failed");
        return(MGMT_FAIL);
    }

    if (ret_struct->status != MGMT_SUCCESS) {

        if (ret_struct->status != MGMT_WARN) {
            printf("\nCall to start ACMS TSC failed with status %d",
                ret_struct->status);
            xdr_free(xdr_cmd_output_rec, ret_struct);
            free(ret_struct);
            return(MGMT_FAIL);
        }

        printf("\n Call to start ACMS TSC completed with warnings or
errors");

        for (nl = ret_struct->cmd_output_rec_u.data.cmd_output; nl != NULL;
            nl = nl->pNext)
            printf("\n %s", nl->dcl_msg);
            xdr_free(xdr_cmd_output_rec, ret_struct);
            free(ret_struct);
            return(MGMT_FAIL);
    }

    else {
        printf("\nCall to start ACMS TSC was executed");
        for (nl = ret_struct->cmd_output_rec_u.data.cmd_output; nl !=
NULL;
            nl = nl->pNext)
            printf("\n %s", nl->dcl_msg);
    }

    xdr_free(xdr_cmd_output_rec, ret_struct);
    free(ret_struct);
    return(0);
}
```

In the preceding example, the `acmsgmt_start_tsc_1` procedure is called to start the terminal subsystem on the target node. If the call succeeds, the terminal subsystem is started on the target node. Otherwise, any error messages associated with the failure are displayed. The example in Section 6.3.1 shows how to declare and initialize the input arguments to this procedure.

## ACMSMGMT\_STOP\_1

ACMSMGMT\_STOP\_1 — This procedure initiates shutdown of the Remote Manager server on a particular node.

### Format

```
int *acmsmgmt_stop_1(sub_id_struct *sub_rec, CLIENT *cl)
```

### Parameters

#### sub\_rec

Type:	Sub_id_struct *	
Access:	Read	
Mechanism:	By reference	
Usage:	Structure that contains the following client authorization information.	
	<i>client_id</i>	
	Type:	Integer
	Access:	Read
	Mechanism:	By value
	Usage:	If explicit authentication is being used, a valid client ID must be provided. If the value for <i>client_id</i> is 0, proxy access is used. <i>Client_id</i> is obtained by calling the <code>acms \$mgmt_get_creds</code> procedure.

#### cl

Type:	CLIENT *
Access:	Read
Mechanism:	By value
Usage:	Pointer to an RPC client handle previously obtained by calling the RPC routine <code>CLNT_CREATE</code> .

### Return Value

Type:	Integer
Access:	Write
Mechanism:	By reference
Usage:	Pointer to status value returned. If the value is NULL or <code>MGMT_SUCCESS</code> , the RPC has succeeded. If the value is neither null nor <code>MGMT_SUCCESS</code> , the call failed and the value pointed to is the reason for failure.

## Description

This procedure shuts down the Remote Manager server on the target node. As part of shutdown, the RPC interface is stopped, which may result in a NULL pointer being returned to the caller. A NULL pointer in this case signals success of the shutdown request.

Note that the success of this procedure does not guarantee that the Remote Manager server has actually shut down. It guarantees only that the shutdown has been requested.

## Example

```
int stop_manager(int client_id,CLIENT *cl)
{
    static int *status;
    static struct sub_id_struct sub_rec;
    sub_rec.client_id = client_id;

    status = acmsmgmt_stop_1(&sub_rec,cl);

    if (!status) {
        printf("\nServer shutdown has been requested");
        return(0);
    }

    if (*status != MGMT_SUCCESS) {
        printf("\n Call to stop server failed with status %d",*status);
        return(MGMT_FAIL);
    }

    printf("\n Server shutdown has been requested");

    return(0);
}
```

In the preceding example, the `acmsmgmt_stop_1` procedure is called to request shutdown of the ACMS Remote Manager. A message is displayed indicating the success or failure of the operation. The example in Section 6.3.1 shows how to declare and initialize the input arguments to this procedure.

## ACMSMGMT\_STOP\_ACC\_1

`ACMSMGMT_STOP_ACC_1` — This procedure requests that the Remote Manager stop the ACMS system.

## Format

```
cmd_output_rec *acmsmgmt_stop_acc_1(acc_shutdown_rec *stop_struct,CLIENT *cl)
```

## Parameters

### stop\_struct

Type:	Acc_shutdown_rec
Access:	Read
Mechanism:	By reference

Usage:	Structure that contains the following client identification and ACC control fields.	
	<i>client_id</i>	
	Type:	Integer
	Access:	Read
	Mechanism:	By value
	Usage:	If explicit authentication is being used, a valid client ID must be provided. If the value for <i>client_id</i> is 0, proxy access is used. <i>Client_id</i> is obtained by calling the acms \$mgmt_get_creds procedure.
	<i>cancel_sw</i>	
	Type:	Integer
	Access:	Read
	Mechanism:	By value
	Usage:	Indicates whether the system should be stopped immediately ( <i>cancel_sw</i> = 1 ), or whether currently executing tasks should be allowed to complete first ( <i>cancel_sw</i> = 0 ).

**cl**

Type:	CLIENT *
Access:	Read
Mechanism:	By value
Usage:	Pointer to an RPC client handle previously obtained by calling the RPC routine CLNT_CREATE.

**Return Value**

Type:	Cmd_output_rec
Access:	Write
Mechanism:	By reference
Usage:	Pointer to a union. The union contains either a failure code or a structure of type <i>cmd_rec_r</i> , which points to a linked list containing status messages. The following are the contents of this union:
<i>status</i>	
Type:	Integer

Access:	Write
Mechanism:	By value
Usage:	Failure return code.
<i>rc</i>	
Type:	Integer
Access:	Write
Mechanism:	By value
Usage:	Failure return code.
<i>data, data_warn</i>	
Type:	Cmd_rec
Access:	Write
Mechanism:	By value
Usage:	Structure containing the first node in a linked list of status messages (type dcl_list). The following are the contents of this structure:
<i>cmd_output</i>	
Type:	Dcl_list
Access:	Write
Mechanism:	By reference
Usage:	Pointer to a linked list of records containing status messages related to the failure of any updates. This structure contains the following fields:
<i>dcl_msg</i>	
Type:	Null-terminated string
Access:	Write
Mechanism:	By reference
Usage:	The status message.
<i>pNext</i>	
Type:	Dcl_list
Access:	Write
Mechanism:	By reference

			Usage:	Pointer to the next node in the linked list.
--	--	--	--------	--

## Description

This procedure shuts down the ACMS run-time system on the same node on which the Remote Manager is running. Fields in the input argument determine how the ACMS system will be stopped. If the value for `cancel_sw` is 1, currently executing tasks are cancelled, and the system is stopped. If the value for `cancel_sw` is 0, currently executing tasks are allowed to complete before the system is shut down.

This call executes synchronously. It does not return to the caller until the attempt to stop the system is complete. Any messages associated with an unsuccessful stop of the system are returned in the `cmd_output` linked list.

The `data` and `data_warn` structures contain identical data. If the operation fails, the status field of both structures will be `MGMT_WARN`; in this case, use the `data_warn` structure to fetch the status messages from the `cmd_output` linked list.

If the operation is successful, the status field of both structures will be `MGMT_SUCCESS`. No status messages are associated with a successful call.

If the status field contains `MGMT_FAIL`, the call failed. No status messages are returned; instead, the reason for the failure is contained in the `rc` field.

## Example

```
int stop_acc(int client_id,CLIENT *cl)
{
    dcl_link      *nl;
    static acc_shutdown_rec stop_struct;
    cmd_output_rec *ret_struct;

    stop_struct.client_id = client_id;
    stop_struct.cancel_sw = 1;

    ret_struct = acmsmgmt_stop_acc_1(&stop_struct,cl);

    if (!ret_struct) {
        printf("\n Call to stop ACC failed");
        return(MGMT_FAIL);
    }

    if (ret_struct->status != MGMT_SUCCESS) {
        if (ret_struct->status != MGMT_WARN) {
            printf("\nCall to stop ACMS ACC failed with status %d",
                ret_struct->status);
            xdr_free(xdr_cmd_output_rec, ret_struct);
            free(ret_struct);
            return(MGMT_FAIL);
        }

        printf("\n Call to stop ACMS ACC completed with warnings or
errors");

        for (nl = ret_struct->cmd_output_rec_u.data.cmd_output; nl != NULL;
```



```

        nl = nl->pNext)
    printf("\n %s",nl->dcl_msg);
    xdr_free(xdr_cmd_output_rec, ret_struct);
    free(ret_struct);
    return(MGMT_FAIL);
}
else {
    printf("\nCall to stop ACMS ACC was executed");
    for (nl = ret_struct->cmd_output_rec_u.data.cmd_output; nl !=
NULL;
        nl = nl->pNext)
        printf("\n %s",nl->dcl_msg);
}
    xdr_free(xdr_cmd_output_rec, ret_struct);
    free(ret_struct);
return(0);
}

```

In the preceding example, the `acmsmgmt_stop_acc_1` procedure is called to stop the ACMS runtime system on the target node. The system is stopped abruptly (/CANCEL), terminating any in-process tasks. If the call succeeds, the ACMS system is stopped on the target node. Otherwise, any error messages associated with the failure are displayed. The example in Section 6.3.1 shows how to declare and initialize the input arguments to this procedure.

## ACMSMGMT\_STOP\_EXC\_1

`ACMSMGMT_STOP_EXC_1` — This procedure requests that the Remote Manager stop the ACMS system.

### Format

`cmd_output_rec *acmsmgmt_stop_exc_1(exc_shutdown_rec *stop_struct,CLIENT *cl)`

### Parameters

#### `stop_struct`

Type:	Exc_shutdown_rec	
Access:	Read	
Mechanism:	By reference	
Usage:	Structure that contains the following client identification and Application Execution Controller (EXC ) control fields.	
	<i>client_id</i>	
	Type:	Integer
	Access:	Read
	Mechanism:	By value
	Usage:	If explicit authentication is being used, a valid client ID must be provided. If the value for <code>client_id</code> is 0, proxy access is used. <code>Client_id</code> is

	obtained by calling the acms \$mgmt_get_creds procedure.
<i>cancel_sw</i>	
Type:	Integer
Access:	Read
Mechanism:	By value
Usage:	Indicates whether the application should be stopped immediately ( <i>cancel_sw</i> = 1 ), or whether currently executing tasks should be allowed to complete first ( <i>cancel_sw</i> = 0 ).
<i>appl_name</i>	
Type:	Null-terminated string
Access:	Read
Mechanism:	By reference
Usage:	Name of the application to be stopped.

**cl**

Type:	CLIENT *
Access:	Read
Mechanism:	By value
Usage:	Pointer to an RPC client handle previously obtained by calling the RPC routine CLNT_CREATE.

**Return Value**

Type:	Cmd_output_rec
Access:	Write
Mechanism:	By reference
Usage:	Pointer to a union. The union contains either a failure code or a structure of type cmd_rec_r, which points to a linked list containing status messages. The following are the contents of this union:
<i>status</i>	
Type:	Integer
Access:	Write
Mechanism:	By value
Usage:	Failure return code.

<i>rc</i>	
Type:	Integer
Access:	Write
Mechanism:	By value
Usage:	Failure return code.
<i>data, data_warn</i>	
Type:	Cmd_rec
Access:	Write
Mechanism:	By value
Usage:	Structure containing the first node in a linked list of status messages (type <i>dcl_list</i> ). The following are the contents of this structure:
<i>cmd_output</i>	
Type:	Dcl_list
Access:	Write
Mechanism:	By reference
Usage:	Pointer to a linked list of records containing status messages related to the failure of any updates. This structure contains the following fields:
<i>dcl_msg</i>	
Type:	Null-terminated string
Access:	Write
Mechanism:	By reference
Usage:	The status message.
<i>pNext</i>	
Type:	Dcl_list
Access:	Write
Mechanism:	By reference
Usage:	Pointer to the next node in the linked list.

## Description

This procedure shuts down an ACMS application on the same node on which the Remote Manager is running. Fields in the input argument determine which application to stop (*appl\_name*) and how the

application will be stopped. If the value for `cancel_sw` is 1, currently executing tasks are cancelled, and the application is stopped. If the value for `cancel_sw` is 0, currently executing tasks are allowed to complete before the application is shut down.

This call executes synchronously. It does not return to the caller until the attempt to stop the application is complete. Any messages associated with an unsuccessful stop of the system are returned in the `cmd_output` linked list.

The `data` and `data_warn` structures contain identical data. If the operation fails, the status field of both structure will be `MGMT_WARN`; in this case, use the `data_warn` structure to fetch the status messages from the `cmd_output` linked list.

If the operation is successful, the status field of both structures will be `MGMT_SUCCESS`. No status messages are associated with a successful call.

If the status field contains `MGMT_FAIL`, the call failed. No status messages are returned; instead, the reason for the failure is contained in the `rc` field.

## Example

```
int stop_exc(int client_id, CLIENT *cl)
{
    dcl_link      *nl;
    static char c_appl_name[] = "VR_APPL";
    static exc_shutdown_rec stop_struct;
    cmd_output_rec *ret_struct;

    stop_struct.client_id = client_id;
    stop_struct.cancel_sw = 1;
    stop_struct.appl_name = c_appl_name;

    ret_struct = acmsgmt_stop_exc_1(&stop_struct, cl);

    if (!ret_struct) {
        printf("\n Call to stop EXC failed");
        return(MGMT_FAIL);
    }

    if (ret_struct->status != MGMT_SUCCESS) {

        if (ret_struct->status != MGMT_WARN) {
            printf("\nCall to stop ACMS EXC failed with status %d",
                ret_struct->status);
            xdr_free(xdr_cmd_output_rec, ret_struct);
            free(ret_struct);
            return(MGMT_FAIL);
        }

        printf("\n Call to stop ACMS EXC completed with warnings or errors");

        for (nl = ret_struct->cmd_output_rec_u.data.cmd_output; nl !=
            NULL;
            nl = nl->pNext)
            printf("\n %s", nl->dcl_msg);
            xdr_free(xdr_cmd_output_rec, ret_struct);
            free(ret_struct);
            return(MGMT_FAIL);
    }
}
```

```

    }

    else {
        printf("\nCall to stop ACMS EXC was executed");
        for (nl = ret_struct->cmd_output_rec_u.data.cmd_output; nl !=
            NULL;
            nl = nl->pNext)
            printf("\n %s",nl->dcl_msg);
    }

    xdr_free(xdr_cmd_output_rec, ret_struct);
    free(ret_struct);
    return(0);
}

```

In the preceding example, the `acmsmgmt_stop_exc_1` procedure is called to stop an application named `VR_APPL` on the target node. If the call succeeds, the `VR_APPL` application is stopped on the target node. Otherwise, any error messages associated with the failure are displayed. The example in Section 6.3.1 shows how to declare and initialize the input arguments to this procedure.

## ACMSMGMT\_STOP\_QTI\_1

`ACMSMGMT_STOP_QTI_1` — This procedure requests that the Remote Manager stop a Queued Task Initiator (QTI) on the same node on which the Remote Manager is running.

### Format

`cmd_output_rec *acmsmgmt_stop_qti_1(sub_id_struct *sub_rec,CLIENT *cl)`

### Parameters

#### `sub_rec`

Type:	Sub_id_struct *	
Access:	Read	
Mechanism:	By reference	
Usage:	Structure that contains the following client authorization information.	
	<i>client_id</i>	
	Type:	Integer
	Access:	Read
	Mechanism:	By value
	Usage:	If explicit authentication is being used, a valid client ID must be provided. If the value for <code>client_id</code> is 0, proxy access is used. <code>Client_id</code> is obtained by calling the <code>acms \$mgmt_get_creds</code> procedure.

**cl**

Type:	CLIENT *
Access:	Read
Mechanism:	By value
Usage:	Pointer to an RPC client handle previously obtained by calling the RPC routine CLNT_CREATE.

**Return Value**

Type:	Cmd_output_rec	
Access:	Write	
Mechanism:	By reference	
Usage:	Pointer to a union. The union contains either a failure code or a structure of type cmd_rec_r, which points to a linked list containing status messages. The following are the contents of this union:	
	<i>status</i>	
	Type:	Integer
	Access:	Write
	Mechanism:	By value
	Usage:	Failure return code.
	<i>rc</i>	
	Type:	Integer
	Access:	Write
	Mechanism:	By value
	Usage:	Failure return code.
	<i>data, data_warn</i>	
	Type:	Cmd_rec
	Access:	Write
	Mechanism:	By value
	Usage:	Structure containing the first node in a linked list of status messages (type dcl_list). The following are the contents of this structure:
	<i>cmd_output</i>	
	Type:	Dcl_list
	Access:	Write
	Mechanism:	By reference

		Usage:	Pointer to a linked list of records containing status messages related to the failure of any updates. This structure contains the following fields:
			<i>dcl_msg</i>
		Type:	Null-terminated string
		Access:	Write
		Mechanism:	By reference
		Usage:	The status message.
			<i>pNext</i>
		Type:	Dcl_list
		Access:	Write
		Mechanism:	By reference
		Usage:	Pointer to the next node in the linked list.

## Description

This procedure requests to stop an ACMS QTI on the same node on which the Remote Manager is running.

This call executes synchronously. It does not return to the caller until the attempt to stop the QTI is complete. Any messages associated with an unsuccessful stop of the QTI are returned in the `cmd_output` linked list.

The `data` and `data_warn` structures contain identical data. If the operation fails, the status field of both structures will be `MGMT_WARN`; in this case, use the `data_warn` structure to fetch the status messages from the `cmd_output` linked list.

If the operation is successful, the status field of both structures will be `MGMT_SUCCESS`. No status messages are associated with a successful call.

If the status field contains `MGMT_FAIL`, the call failed. No status messages are returned; instead, the reason for the failure is contained in the `rc` field.

## Example

```
int stop_qti(int client_id, CLIENT *cl)
{
    dcl_link    *nl;
    static struct sub_id_struct sub_rec;
    cmd_output_rec *ret_struct;

    sub_rec.client_id = client_id;
```

```

ret_struct = acmsmgmt_stop_qti_1(&sub_rec,cl);

if (!ret_struct) {
    printf("\n Call to stop qti failed");
    return(MGMT_FAIL);
}

if (ret_struct->status != MGMT_SUCCESS) {

if (ret_struct->status != MGMT_WARN) {
    printf("\nCall to stop ACMS QTI failed with status %d",
        ret_struct->status);
    xdr_free(xdr_cmd_output_rec, ret_struct);
    free(ret_struct);
    return(MGMT_FAIL);
}

    printf("\n Call to stop ACMS QTI completed with warnings or
errors");

    for (nl = ret_struct->cmd_output_rec_u.data.cmd_output; nl !=
NULL;
        nl = nl->pNext)
        printf("\n %s",nl->dcl_msg);
        xdr_free(xdr_cmd_output_rec, ret_struct);
        free(ret_struct);
    return(MGMT_FAIL);
}

else {
    printf("\nCall to stop ACMS QTI was executed");
    for (nl = ret_struct->cmd_output_rec_u.data.cmd_output; nl !=
NULL;
        nl = nl->pNext)
        printf("\n %s",nl->dcl_msg);
    }
    xdr_free(xdr_cmd_output_rec, ret_struct);
    free(ret_struct);
return(0);
}

```

In the preceding example, the `acmsmgmt_stop_qti_1` procedure is called to stop the Queued Task Initiator (QTI) on the target node. If the call succeeds, the QTI is stopped on the target node. Otherwise, any error messages associated with the failure are displayed. The example in Section 6.3.1 shows how to declare and initialize the input arguments to this procedure.

## ACMSMGMT\_STOP\_TRACE\_MONITOR\_1

`ACMSMGMT_STOP_TRACE_MONITOR_1` — This procedure requests that the Remote Manager stop the `ACMS$TRACE_MONITOR` process. The `ACMS$TRACE_MONITOR` process is an intermediate process used by the Remote Manager to communicate with ACMS run-time processes to enable and disable collections.

### Format

```
int *acmsmgmt_stop_trace_monitor_1(sub_id_struct *sub_rec,CLIENT *cl)
```



## Parameters

### sub\_rec

Type:	Sub_id_struct	
Access:	Read	
Mechanism:	By reference	
Usage:	Structure that contains the following client authorization information.	
	<i>client_id</i>	
	Type:	Integer
	Access:	Read
	Mechanism:	By value
	Usage:	If explicit authentication is being used, a valid client ID must be provided. If the value for <i>client_id</i> is 0, proxy access is used. <i>Client_id</i> is obtained by calling the acms \$mgmt_get_creds procedure.

### cl

Type:	CLIENT *
Access:	Read
Mechanism:	By value
Usage:	Pointer to an RPC client handle previously obtained by calling the RPC routine CLNT_CREATE.

## Return Value

Type:	Integer
Access:	Write
Mechanism:	By reference
Usage:	Pointer to status value returned. If the value is NULL or MGMT_SUCCESS, the RPC has succeeded. If the value is neither NULL nor MGMT_SUCCESS, the call failed and the value pointed to is the reason for failure.

## Description

This procedure requests that the Remote Manager stop the ACMS\$TRACE\_MONITOR process on the target node. The ACMS\$TRACE\_MONITOR process is an intermediate process used by the Remote Manager to communicate with ACMS run-time processes to enable and disable collections.

In general, external entities do not require a startup and shutdown request of the trace monitor process. The Remote Manager starts the trace monitor during process initialization and stops it during process shutdown. Additionally, the Remote Manager starts the trace monitor anytime it is needed if it is not already started. Once started, the trace monitor continues to run until the Remote Manager shuts down.

After issuing the stop command to the trace monitor, the Remote Manager waits for a period of up to `trace_start_wait_time`, a Parameter table parameter that is dynamic and expressed in seconds. If the trace monitor fails to stop during that period, the Remote Manager returns an error to the caller.

## Example

```
int stop_trace(int client_id,CLIENT *cl)
{
    int *status;
    static struct sub_id_struct sub_rec;

    sub_rec.client_id = client_id;

    status = acmsgmt_stop_trace_monitor_1(&sub_rec,cl);

    if (!status) {
        printf("\nShutdown of Trace Monitor has failed");
        return(MGMT_FAIL);
    }

    if (*status != MGMT_SUCCESS) {
        printf("\nShutdown of Trace Monitor has failed with return code %d",
            *status);
        free(status);
        return(MGMT_FAIL);
    }

    printf("\nTrace Monitor has been stopped ");
    free(status);
    return(MGMT_SUCCESS);
}
```

In the preceding example, the `acmsgmt_stop_trace_monitor_1` procedure is called to stop the `ACMS$TRACE_MON` process on the target node. If the call succeeds, the process is stopped. Otherwise, any error messages associated with the failure are displayed. The example in Section 6.3.1 shows how to declare and initialize the input arguments to this procedure.

# Chapter 9. Remote Manager Reference Tables

This chapter contains information about data types that the Remote Manager implements and the reference tables for the Remote Manager. The Remote Manager reference tables include the following:

- ACC table
- Agent table
- Collection table
- CP table
- EXC table
- Interfaces table
- Manager status table
- Parameter table
- QTI table
- Server table
- Task Group table
- Trap table
- TSC table
- Users table

---

## Note

The following sections describe the records and fields in each Remote Manager reference table. Many of these tables now contain a subset of fields intended solely for use on or by systems running ACMS Version 4.4 or higher.

---

## 9.1. Data Types

The ACMS Remote Manager implements the following data types:

- Gauge and Min Gauge

Gauge fields are structures containing the following fields:

- `current_value`

The value of the object when last observed. Represents the most current known value.

- `max_value` or `min_value`

The largest or smallest observed value for the object.

- `time_max_seen` or `time_min_seen`

The date and time the `max_value` or `min_value` was set.

- Integer

Integer fields are 32-bit signed integers.

- State 1

State 1 fields are integers with two possible values:

- `MGMT$K_STATE_DISABLED`
- `MGMT$K_STATE_ENABLED`

- State 2

State 2 fields are integers with the following possible values:

- `MGMT$K_STATE_INITED`
- `MGMT$K_STATE_INITING`
- `MGMT$K_STATE_LOAD_DONE`
- `MGMT$K_STATE_LOADING`
- `MGMT$K_STATE_STARTED`
- `MGMT$K_STATE_STARTING`
- `MGMT$K_STATE_STOPPED`
- `MGMT$K_STATE_STOPPING`

- String

String fields are null-terminated ASCII strings.

- Time

Time fields are stored internally in OpenVMS internal time format and are generally displayed as *DD-MMM-YYY HH:MM:SS.hh*. When present in a record supplied by the Remote Manager (that is, from either an RPC or SNMP call, or in a file), time is always an ASCII value in the default OpenVMS format (*DD-MMM-YYYY HH:MM:SS.hh*) and is stored as a null-terminated string.

## 9.2. ACC Table

The ACC table contains a single entry for ACC management information.

---

**Table 9.1. ACC Table**

Class	Field	Data Type	SNMP Access	RPC Access	Dynamic
ID	record_state	integer	R	R	
ID	id_coll_state	integer	R	R	
ID	process_name	string	R	R	
ID	pid	integer	R	R	
ID	username_active	string	R	R	
ID	username_stored	string	R	R	
ID	start_time	time	R	R	
ID	end_time	time	R	R	
ID	acms_version	string	R	R	
CONFIG	config_coll_state	integer	R	R	
CONFIG	acms_state	integer	RW	R	D
CONFIG	acc_priority_active	integer	R	R	
CONFIG	acc_priority_stored	integer	RW	RW	
CONFIG	max_appl_active	integer	R	R	
CONFIG	max_appl_stored	integer	RW	RW	
CONFIG	mss_maxobj_active	integer	R	R	
CONFIG	mss_maxobj_stored	integer	RW	RW	
CONFIG	mss_maxbuf_active	integer	R	R	
CONFIG	mss_maxbuf_stored	integer	RW	RW	
CONFIG	mss_poolsize_active	integer	R	R	
CONFIG	mss_poolsize_stored	integer	RW	RW	
CONFIG	mss_process_pool_active	integer	R	R	
CONFIG	mss_process_pool_stored	integer	RW	RW	
CONFIG	mss_net_retry_time_active	integer	RW	RW	D
CONFIG	mss_net_retry_time_stored	integer	RW	RW	
CONFIG	audit_state	integer	RW	RW	D
CONFIG	username_default_active	integer	RW	RW	D
CONFIG	username_default_stored	integer	RW	RW	
CONFIG	node_name_active	integer	R	R	
CONFIG	node_name_stored	integer	RW	RW	
CONFIG	ws_poolsize_active	integer	R	R	
CONFIG	ws_poolsize_stored	integer	RW	RW	
<b>Key to Access Modes</b>					
<b>R – Read Access</b>					
<b>RW – Read/Write Access</b>					
<b>Blank – Not available to the interface</b>					
<b>D – Field is dynamic.</b>					

Class	Field	Data Type	SNMP Access	RPC Access	Dynamic
CONFIG	wsc_poolsize_active	integer	R	R	
CONFIG	wsc_poolsize_stored	integer	RW	RW	
CONFIG	tws_poolsize_active	integer	R	R	
CONFIG	tws_poolsize_stored	integer	RW	RW	
CONFIG	twsc_poolsize_active	integer	R	R	
CONFIG	twsc_poolsize_stored	integer	RW	RW	
RUNTIME	runtime_coll_state	integer	R	R	
RUNTIME	current_appls	gauge	R	R	
RUNTIME	current_users	gauge	R	R	
RUNTIME	current_local_users	gauge	R	R	
RUNTIME	current_remote_users	gauge	R	R	
RUNTIME	appl_starts	integer	R	R	
RUNTIME	decnet_object	integer	R	R	
POOL	pool_coll_state	integer	R	R	
POOL	mss_shared_total	integer	R	R	
POOL	mss_shared_free	min gauge	R	R	
POOL	mss_shared_large	min gauge	R	R	
POOL	mss_shared_failures	integer	R	R	
POOL	mss_shared_garbage	integer	R	R	
POOL	mss_process_total	integer	R	R	
POOL	mss_process_free	min gauge	R	R	
POOL	mss_process_large	min gauge	R	R	
POOL	mss_process_failures	integer	R	R	
POOL	mss_process_garbage	integer	R	R	
POOL	mss_objects	gauge	R	R	
<b>Key to Access Modes</b> <b>R – Read Access</b> <b>RW – Read/Write Access</b> <b>Blank – Not available to the interface</b> <b>D – Field is dynamic.</b>					

## 9.2.1. Field Descriptions

Following are descriptions of the fields in Table 9.1.

- record\_state

The current state of this table entry. Valid states are VALID (the process is currently running and maintaining this table entry) or INACTIVE (the process is no longer running). Inactive rows are subject to reuse.

- id\_coll\_state

The current collection state for this class and this process. Collection states can be modified by modifying entries in the Collection table. See Section 5.1 and Section 9.4 for discussions of data collection.

- process\_name

The OpenVMS process name for the process.

- pid

The OpenVMS process identifier for the process.

- username\_active

The OpenVMS user name under which the process is currently running. This is the value that was in the ACMSGEN file when the process was started.

- username\_stored

The OpenVMS process name currently stored in the ACMSGEN file for this process.

- start\_time

Date and time the process was started.

- end\_time

Date and time the process ended. If the process has not yet ended, this field will be null.

- acms\_version

Current version of the ACC.

- config\_coll\_state

The current collection state for this class and this process. Collection states can be modified by modifying entries in the Collection table. See Section 5.1 and Section 9.4 for discussions of data collection.

- acc\_priority\_active

The base priority for this process. This is the value of the ACMSGEN field when the process was started.

- acc\_priority\_stored

The base priority currently stored in the ACMSGEN file for this process.

- max\_appl\_active

The maximum number of ACMS applications that can be started simultaneously on this node. This is the value of the ACMSGEN field when the ACC process was started.

- max\_appl\_stored

The value of the max\_appl field currently stored in the ACMSGEN file.

- `mss_maxobj_active`

The maximum number of ACMS message switch objects that can be started simultaneously on this node. This is the value of the ACMSGEN field when the ACC process was started. See the MSS class field `mss_objects` for a count of the current and maximum number of MSS objects instantiated on the system.

- `mss_maxobj_stored`

The value of the `mss_maxobj` field currently stored in the ACMSGEN file.

- `mss_maxbuf_active`

The maximum size of a message segment of an ACMS message switch message. This is the value of the ACMSGEN field when the ACC process was started.

- `mss_maxbuf_stored`

The value of the `mss_maxbuf` field currently stored in the ACMSGEN file.

- `mss_poolsize_active`

The size of the MSS shared pool. This is the value of the ACMSGEN field when the ACC process was started.

- `mss_poolsize_stored`

The value of the `mss_poolsize` field currently stored in the ACMSGEN file.

- `mss_process_pool_active`

The default size of the MSS pool allocated for each ACMS process. This is the value of the ACMSGEN field when the ACC process was started.

- `mss_process_pool_stored`

The value of the `mss_process_pool` field currently stored in the ACMSGEN file.

- `mss_net_retry_active`

The time ACMS processes will wait before retrying an MSS network operation. This field can be modified dynamically.

- `mss_net_retry_timer_stored`

The value of the `mss_net_retry_timer` field currently stored in the ACMSGEN file.

- `audit_state`

The current system auditing state.

- `username_default_active`

The default user name for remote users. This is the value of the ACMSGEN field when the ACC process was started.



- `username_default_stored`

The value of the `username_default` field currently stored in the ACMSGEN file.

- `node_name_active`

The node name for the current node. This is the value of the ACMSGEN field when the ACC process was started.

- `node_name_stored`

The value of the `node_name` field currently stored in the ACMSGEN file.

- `ws_poolsize_active`

The default size for WS pools. This is the value of the ACMSGEN field when the ACC process was started.

- `ws_poolsize_stored`

The value of the `ws_poolsize` field currently stored in the ACMSGEN file.

- `wsc_poolsize_active`

The default size for WSC pools. This is the value of the ACMSGEN field when the ACC process was started.

- `wsc_poolsize_stored`

The value of the `wsc_poolsize` field currently stored in the ACMSGEN file.

- `tws_poolsize_active`

The default size for TWS pools. This is the value of the ACMSGEN field when the ACC process was started.

- `tws_poolsize_stored`

The value of the `twsc_poolsize` field currently stored in the ACMSGEN file.

- `twsc_poolsize_active`

The default size for TWSC pools. This is the value of the ACMSGEN field when the ACC process was started.

- `twsc_poolsize_stored`

The value of the `twsc_poolsize` field currently stored in the ACMSGEN file.

- `acms_state`

Current ACMS state of the process. This field can be set (to `DISABLED` or to `0`) by the SNMP interface only. RPC users use the `ACMSMGMT_STOP_ACC_1` procedure described in `ACMSMGMT_STOP_ACC_1`. ACMSMGR users use the `STOP SYSTEM` command.

- `runtime_coll_state`

The current collection state for this class and this process. Collection states can be modified by modifying entries in the Collection table. See Section 5.1 and Section 9.4 for discussions of data collection.

If this field is set to DISABLED, the process is not currently collecting data for the fields in this class. Any field values reflect activity during a prior period when collection was enabled.

- `current_appls`

The number of applications currently running on the node.

- `current_users`

The number of users currently logged in to the node.

- `current_local_users`

The number of current users logged in to ACMS locally.

- `current_Remote_users`

The number of current users who are logged in to ACMS remotely.

- `appl_starts`

The number of applications that have been started on the node since the system was started.

- `decnet_object`

If the process has a current DECnet object, the value of this field is STARTED. Otherwise, the value is STOPPED. If the DECnet object is stopped (and the `runtime_coll_state` is enabled for this process), either distributed processing has not been enabled (that is, the `node_name` parameter in the ACMSGEN file is NULL) or there is currently a problem with DECnet. Also, check the ACC CONFIG parameters `node_name_active` and `node_name_stored` to determine the current status of the ACMSGEN `node_name` field.

- `pool_coll_state`

The current collection state for this class and this process. Collection states can be modified by modifying entries in the Collection table. See Section 5.1 and Section 9.4 for discussions of data collection.

If this field is set to DISABLED, the process is not currently collecting data for the fields in this class. Any field values reflect activity during a prior period when collection was enabled.

- `mss_shared_total`

The total size (in bytes) of the MSS shared pool on this node. The frequency with which this field is updated is based on the value of the Parameter table field `mss_coll_interval` (see Table 9.8).

- `mss_shared_free`

The amount (in bytes) of unused MSS shared pool. The frequency with which this field is updated is based on the value of the Parameter table field `mss_coll_interval` (see Table 9.8).

- `mss_shared_largest`

The largest unused block (in bytes) available in the MSS shared pool. The frequency with which this field is updated is based on the value of the Parameter table field `mss_coll_interval` (see Table 9.8).

- `mss_shared_failures`

The number of failed attempts to allocate space from the MSS shared pool. The frequency with which this field is updated is based on the value of the Parameter table field `mss_coll_interval` (see Table 9.8).

- `mss_shared_garbage`

The number of garbage collections that have been run to reclaim space in the MSS shared pool. The frequency with which this field is updated is based on the value of the Parameter table field `mss_coll_interval` (see Table 9.8).

- `mss_process_total`

The total size (in bytes) of the MSS process pool allocated for this process. The frequency with which this field is updated is based on the value of the Parameter table field `mss_coll_interval` (see Table 9.8).

- `mss_process_free`

The amount of unused MSS process pool (in bytes) for this process. The frequency with which this field is updated is based on the value of the Parameter table field `mss_coll_interval` (see Table 9.8).

- `mss_process_largest`

The largest unused block (in bytes) available in the MSS process pool for this process. The frequency with which this field is updated is based on the value of the Parameter table field `mss_coll_interval` (see Table 9.8).

- `mss_process_failures`

The number of failed attempts to allocate space in the MSS process pool for this process. The frequency with which this field is updated is based on the value of the Parameter table field `mss_coll_interval` (see Table 9.8).

- `mss_process_garbage`

The number of garbage collections for this process that have been run to reclaim space in the MSS process pool. The frequency with which this field is updated is based on the value of the Parameter table field `mss_coll_interval` (see Table 9.8).

- `mss_objects`

The number of MSS objects currently instantiated on the node. The frequency with which this field is updated is based on the value of the Parameter table field `mss_coll_interval` (see Table 9.8).

## 9.3. Agent Table

Table 9.2. Agent Table

Class	Field	Data Type	SNMP Access	RPC Access	Dynamic
ID	record_state	integer	R	R	
ID	id_coll_state	integer	R	R	
ID	process_name	string	R	R	
ID	pid	integer	R	R	
ID	start_time	time	R	R	
ID	end_time	time	R	R	
ID	user_name	string	R	R	
ID	acms_state	integer	R	R	
CONFIG	cfg_coll_state	integer	R	R	
CONFIG	astlm_active	integer	R	R	
CONFIG	astlm_stored	integer	RW	RW	
CONFIG	biolm_active	integer	R	R	
CONFIG	biolm_stored	integer	RW	RW	
CONFIG	bytlm_active	integer	R	R	
CONFIG	bytlm_stored	integer	RW	RW	
CONFIG	diolm_active	integer	R	R	
CONFIG	diolm_stored	integer	RW	RW	
CONFIG	enqlm_active	integer	R	R	
CONFIG	enqlm_stored	integer	RW	RW	
CONFIG	fillm_active	integer	R	R	
CONFIG	fillm_stored	integer	RW	RW	
CONFIG	pgflquota_active	integer	R	R	
CONFIG	pgflquota_stored	integer	RW	RW	
CONFIG	tqelm_active	integer	R	R	
CONFIG	tqelm_stored	integer	RW	RW	
CONFIG	wsdefault_active	integer	R	R	
CONFIG	wsdefault_stored	integer	RW	RW	
CONFIG	wsextent_active	integer	R	R	
CONFIG	wsextent_stored	integer	RW	RW	
CONFIG	wsquota_active	integer	R	R	
<b>Key to Access Modes</b> <b>R – Read Access</b> <b>RW – Read/Write Access</b> <b>Blank – Not available to the interface</b> <b>D – Field is dynamic.</b>					

Class	Field	Data Type	SNMP Access	RPC Access	Dynamic
CONFIG	wsquota_stored	integer	RW	RW	
RUNTIME	rt_coll_state	integer	R	R	
RUNTIME	decnet_object	integer	R	R	
RUNTIME	active_task_calls	gauge	R	R	
RUNTIME	current_attached	gauge	R	R	
RUNTIME	active_tdms_msgs	gauge	R	R	
RUNTIME	total_tdms_msgs	integer	R	R	
RUNTIME	active_tdms_reqs	gauge	R	R	
RUNTIME	active_tdms_msgs	gauge	R	R	
RUNTIME	active_tdms_msgs	gauge	R	R	
RUNTIME	active_tdms_calls	gauge	R	R	
RUNTIME	total_tdms_reqs	integer	R	R	
RUNTIME	total_tdms_msgs	integer	R	R	
RUNTIME	total_tdms_msgs	integer	R	R	
RUNTIME	total_tdms_calls	integer	R	R	
RUNTIME	active_vf_msgs	gauge	R	R	
RUNTIME	total_vf_msgs	integer	R	R	
RUNTIME	active_vf_reqs	gauge	R	R	
RUNTIME	active_vf_enabled	gauge	R	R	
RUNTIME	active_vf_disabled	gauge	R	R	
RUNTIME	active_vf_cancel	gauge	R	R	
RUNTIME	active_vf_send	gauge	R	R	
RUNTIME	active_vf_receive	gauge	R	R	
RUNTIME	active_vf_xceive	gauge	R	R	
RUNTIME	total_vf_reqs	integer	R	R	
RUNTIME	total_vf_enabled	integer	R	R	
RUNTIME	total_vf_disabled	integer	R	R	
RUNTIME	total_vf_cancel	integer	R	R	
RUNTIME	total_vf_send	integer	R	R	
RUNTIME	total_vf_receive	integer	R	R	
RUNTIME	total_vf_xceive	integer	R	R	
RUNTIME	total_tasks_executed	integer	R	R	
RUNTIME	userl_time	time	RW	RW	
<b>Key to Access Modes</b>					
<b>R – Read Access</b>					
<b>RW – Read/Write Access</b>					
<b>Blank – Not available to the interface</b>					
<b>D – Field is dynamic.</b>					

Class	Field	Data Type	SNMP Access	RPC Access	Dynamic
RUNTIME	user2_time	time	RW	RW	
RUNTIME	user3_time	time	RW	RW	
RUNTIME	user1_data	integer	RW	RW	
RUNTIME	user2_data	integer	RW	RW	
RUNTIME	user3_data	integer	RW	RW	
RUNTIME	user4_data	integer	RW	RW	
RUNTIME	user5_data	integer	RW	RW	
RUNTIME	user6_data	integer	RW	RW	
RUNTIME	astlm_current	gauge	R	R	
RUNTIME	biolm_current	gauge	R	R	
RUNTIME	bytlm_current	gauge	R	R	
RUNTIME	diolm_current	gauge	R	R	
RUNTIME	enqlm_current	gauge	R	R	
RUNTIME	fillm_current	gauge	R	R	
RUNTIME	pgflquota_current	gauge	R	R	
RUNTIME	tqelm_current	gauge	R	R	
RUNTIME	wssize_current	gauge	R	R	
RUNTIME	channelcnt_current	gauge	R	R	
POOL	pool_coll_state	integer	R	R	
POOL	mss_process_total	integer	R	R	
POOL	mss_process_free	integer	R	R	
POOL	mss_process_languages	integer	R	R	
POOL	mss_process_files	integer	R	R	
POOL	mss_process_garbage	integer	R	R	
ERROR	err_coll_state	integer	R	R	
ERROR	err_count	integer	R	R	
ERROR	last_err_msg	string	R	R	
ERROR	time_of_last_error	time	R	R	
<b>Key to Access Modes</b> <b>R – Read Access</b> <b>RW – Read/Write Access</b> <b>Blank – Not available to the interface</b> <b>D – Field is dynamic.</b>					

## Note

Items marked with ‡ are only valid for use with systems running ACMS Version 4.4 or higher.

## 9.3.1. Field Descriptions

Following are descriptions of the fields in the table above.

- record\_state

The current state of this table entry. Valid states are VALID (the process is currently running and maintaining this table entry) or INACTIVE (the process is no longer running). Inactive rows are subject to reuse.

- id\_coll\_state

The current collection state for this class and this process. Collection states can be modified by modifying entries in the Collection table. If this field is set to DISABLED, the process is not currently collecting data for the fields in this class. Any field values reflect activity during a prior period when collection was enabled.

- process\_name

The OpenVMS process name for the process.

- pid

The OpenVMS process identifier for the process.

- start\_time

Date and time the process was started.

- end\_time

Date and time the process ended. If the process has not yet ended, this field is null.

- user\_name

The OpenVMS account under which the process is running.

- acms\_state

The ACMS state of the process.

- cfg\_coll\_state

Collection states can be modified by modifying entries in the Collection table. If this field is set to DISABLED, the process is not currently collecting data for the fields in this class. Any field values reflect activity during a prior period when collection was enabled.

- astlm\_active, biolm\_active, bytlm\_active, diolm\_active, enqlm\_active, fillm\_active, pgflquota\_active, tqelm\_active, wsdefault\_active, wsextent\_active, wsquota\_active

The default value of the related OpenVMS process quota. This is the value of the quota when the Agent process was started.

- astlm\_stored, biolm\_stored, bytlm\_stored, diolm\_stored, enqlm\_stored, fillm\_stored, pgflquota\_stored, tqelm\_stored, wsdefault\_stored, wsextent\_stored, wsquota\_stored

The value of the related process quota currently stored in the OpenVMS system user authorization file (SYSUAF.DAT).

- `rt_coll_state`

The current collection state for this class and this process. Collection states can be modified by modifying entries in the Collection table. If this field is set to `DISABLED`, the process is not currently collecting data for the fields in this class. Any field values reflect activity during a prior period when collection was enabled.

- `decnet_object`

If the process has a current DECnet object, the value of this field is `STARTED`. Otherwise, the value is `STOPPED`. If the DECnet object is stopped (and the `runtime_coll_state` is enabled for this process), either distributed processing has not been enabled (that is, the `node_name` parameter in the `ACMSGGEN` file is `NULL`) or there is currently a problem with DECnet. Also, check the `ACC CONFIG` parameters `node_name_active` and `node_name_stored` to determine the current status of the `ACMSGGEN node_name` field.

- `active_task_calls`

The number of task calls currently being executed by all users of the Agent.

- `current_attached_terms`

The number of terminals currently attached to the Agent.

- `active_tdms_menu_reqs`

The number of TDMS menu requests currently being executed by all users of the Agent.

- `total_tdms_menu_reqs`

The total number of TDMS menu requests executed by all users of the Agent since the Agent was started.

- `active_tdms_reqs`

The number of TDMS requests of all types currently being executed by all users of the Agent.

- `active_tdms_msgrd`

The number of TDMS read messages currently being executed by all users of the Agent.

- `active_tdms_msgwt`

The number of TDMS write messages currently being executed by all users of the Agent.

- `active_tdms_cancel`

The number of TDMS cancels currently being executed by all users of the Agent.

- `total_tdms_reqs`

The total number of TDMS requests (menu and exchange) executed by all users of the Agent since the Agent was started.



- `total_tdms_msgrd`

The total number of TDMS read messages executed by all users of the Agent since the Agent was started.

- `total_tdms_msgwt`

The total number of TDMS write messages executed by all users of the Agent since the Agent was started.

- `total_tdms_cancel`

The total number of TDMS cancels executed by all users of the Agent since the Agent was started.

- `active_vf_menu_reqs`

The number of VSI DECforms menu requests currently being executed by all users of the Agent.

- `total_vf_menu_reqs`

The total number of VSI DECforms menu requests executed by all users of the Agent since the Agent was started.

- `active_vf_reqs`

The number of VSI DECforms requests of all types currently being executed by all users of the Agent.

- `active_vf_enable`

The number of VSI DECforms enable requests currently being executed by all users of the Agent.

- `active_vf_disable`

The number of VSI DECforms disable requests currently being executed by all users of the Agent.

- `active_vf_cancel`

The number of VSI DECforms cancel requests currently being executed by all users of the Agent.

- `active_vf_send`

The number of VSI DECforms requests currently being executed by all users of the Agent.

- `active_vf_receive`

The number of VSI DECforms receive requests currently being executed by all users of the Agent.

- `active_vf_xceive`

The number of VSI DECforms enable transceives currently being executed by all users of the Agent.

- `total_vf_reqs`

The total number of VSI DECforms requests of all types executed by all users of the Agent since the Agent was started.

- `total_vf_enable`

The total number of VSI DECforms enable requests executed by all users of the Agent since the Agent was started.

- `total_vf_disable`

The total number of VSI DECforms disable requests executed by all users of the Agent since the Agent was started.

- `total_vf_cancel`

The total number of VSI DECforms cancel requests executed by all users of the Agent since the Agent was started.

- `total_vf_send`

The total number of VSI DECforms send requests executed by all users of the Agent since the Agent was started.

- `total_vf_receive`

The total number of VSI DECforms receive requests executed by all users of the Agent since the Agent was started.

- `total_vf_xceive`

The total number of VSI DECforms transceive requests executed by all users of the Agent since the Agent was started.

- `total_tasks_executed`

The total number of tasks started in the Agent since the Agent was started.

- `user1_time`, `user2_time`, `user3_time`, `user1_data`, `user2_data`, `user3_data`, `user4_data`, `user5_data`, `user6_data`

Additional generic runtime fields that are available to programmers and Agent developers.

- `astlm_current`, `biolm_current`, `bytlm_current`, `diolm_current`, `enqlm_current`, `fillm_current`, `pgflquota_current`, `tqelm_current`, `wssize_current`, `channelcnt_current`

The actual amount of the related OpenVMS process or system resource that is being consumed by the Agent process. The frequency with which these fields are updated is based on the value of the `vms_coll_interval` field in the Parameter table.

- `pool_coll_state`

The current collection state for this class and this process. Collection states can be modified by modifying entries in the Collection table. If this field is set to `DISABLED`, the process is not currently collecting data for the fields in this class. Any field values reflect activity during a prior period when collection was enabled.

- `mss_process_total`

The total size of the MSS process pool allocated for this process. The frequency with which this field is updated is based on the value of the Parameter table field `mss_coll_interval`.

- `mss_process_free`

The amount of unused MSS process pool for this process. The frequency with which this field is updated is based on the value of the Parameter table field `mss_coll_interval`.

- `mss_process_largest`

The largest unused block available in the MSS process pool for this process. The frequency with which this field is updated is based on the value of the Parameter table field `mss_coll_interval`.

- `mss_process_failures`

The number of failed attempts to allocate space in the MSS process pool for this process. The frequency with which this field is updated is based on the value of the Parameter table field `mss_coll_interval`.

- `mss_process_garbage`

The number of garbage collections that have been run to reclaim space in this processes MSS process pool. The frequency with which this field is updated is based on the value of the Parameter table field `mss_coll_interval`.

- `error_coll_state`

The current collection state for this class and this process. Collection states can be modified by modifying entries in the Collection table. Errors for this process are only sent to the Remote Manager if this field is set to `ENABLED`. If this field is set to `DISABLED`, the process will not collect data for the fields in this class; existing field values reflect activity during a prior period when collection was enabled.

- `error_count`

The total number of errors related to this process that were sent to the Remote Manager.

- `last_error_message`

The text of the most recent error message related to this process that was sent to the Remote Manager.

- `time_of_last_error`

Date and time of the most recent error message related to this process that was sent to the Remote Manager.

## 9.4. Collection Table

The Collection table is populated from the configuration file maintained by the user on the local system (or in a cluster common area) when the ACMS run-time system is started.

This table can be used at run time to enable or disable data collection by entity and class. The primary key to this table is the combination of entity, class, and name. Duplicate rows are not allowed.

**Table 9.3. Collection Table**

Field	Data Type	SNMP Access	RPC Access	Configuration Access	Dynamic
entity	string	R	RW	RW	D
class	string	R	RW	RW	D
name	string	R	RW	RW	D
coll_state	state 1	RW	RW	RW	D
<b>Key to Access Modes</b>  <b>R – Read Access</b> <b>RW – Read/Write Access</b> <b>Blank – Not available to the interface</b> <b>D – Field is dynamic.</b>					

## 9.4.1. Field Descriptions

Following are descriptions of the fields in Table 9.3.

- entity

Name or type of the entity. Valid values are ACC, CP, EXC, GROUP, QTI, SERVER, and TSC.

- class

Class of data to be collected. Valid values are CONFIG, ID, POOL, and RUNTIME.

- name

A name for the entity that helps to uniquely identify an instance of the entity type. Possible entity names are:

- ACC, CP, QTI, TSC (process name)
- EXC (application name)
- GROUP (task group name)
- SERVER (server name)

Name can include the following wildcard values:

- asterisk (\*) (matches all characters)
- exclamation point (!) (negation)

- coll\_state

Current state as configured, either from the configuration file or by a user at run time. Valid values are ENABLED or DISABLED. A change to this field causes collection to be initiated or terminated.

## Note

The trap table has not been implemented. The following is subject to change.

The event notification table is used to configure event notifications. The ACMS Management process populates this table from the configuration file at system startup. Thereafter, users make modifications to this table through either the SNMP interface, or the ACMSMGT interface.

It will be possible to disable thresholds by using any negative value (e.g. - 1). No monitoring is performed for a disabled threshold.

A consistency check is performed between this table, the Threshold Monitor table, and the entity/collection table. Parameters are monitored only if there is an active entry in the Threshold Monitor table, and only if the entity being monitored is actively collecting data.

A special parameter (RETURN\_CODE) will be provided to allow alarms and notifications to be generated based on Error class data. When an entry is made in this table with the RETURN\_CODE parameter type, the min and max thresholds determine which return codes will result in a trap. By definition, only non-successful return codes will be monitored. For example, to specify that an error level trap should be generated when any server procedure returns a fatal return code, the entry would be ENTITY=SERVER\_PROC, NAME = \*, PARAMETER=RETURN\_CODE, MIN\_ERROR\_THRESHOLD=FATAL.

## 9.5. CP Table

The CP table contains a row for each terminal Command Process (CP) running on the node.

**Table 9.4. CP Table**

Collection Class	Field	Data Type	SNMP Access	RPC Access	Dynamic
ID	record_state	integer	R	R	
ID	id_coll_state	integer	R	R	
ID	process_name	string	R	R	
ID	pid	integer	R	R	
ID	start_time	time	R	R	
ID	end_time	time	R	R	
ID	user_name	string	R	R	
RUNTIME	runtime_coll_state	integer	R	R	
RUNTIME	acms_state	integer	R	R	
RUNTIME	decnet_object	integer	R	R	
RUNTIME	current_attached_gauges	gauge	R	R	
RUNTIME	active_task_calls	gauge	R	R	
<b>Key to Access Modes</b> <b>R – Read Access</b> <b>RW – Read/Write Access</b> <b>Blank – Not available to the interface</b> <b>D – Field is dynamic</b>					

Collection Class	Field	Data Type	SNMP Access	RPC Access	Dynamic
RUNTIME	active_tdms_menus	gauge	R	R	
RUNTIME	total_tdms_menus	integer	R	R	
RUNTIME	active_tdms_reqs	gauge	R	R	
RUNTIME	active_tdms_reads	gauge	R	R	
RUNTIME	active_tdms_writes	gauge	R	R	
RUNTIME	active_tdms_cancels	gauge	R	R	
RUNTIME	total_tdms_reqs	integer	R	R	
RUNTIME	total_tdms_reads	integer	R	R	
RUNTIME	total_tdms_writes	integer	R	R	
RUNTIME	total_tdms_cancels	integer	R	R	
RUNTIME	active_df_menus	gauge	R	R	
RUNTIME	total_df_menus	integer	R	R	
RUNTIME	active_df_reqs	gauge	R	R	
RUNTIME	active_df_enables	gauge	R	R	
RUNTIME	active_df_disables	gauge	R	R	
RUNTIME	active_df_cancels	gauge	R	R	
RUNTIME	active_df_sends	gauge	R	R	
RUNTIME	active_df_receives	gauge	R	R	
RUNTIME	active_df_transceives	gauge	R	R	
RUNTIME	total_df_reqs	integer	R	R	
RUNTIME	total_df_enables	integer	R	R	
RUNTIME	total_df_disables	integer	R	R	
RUNTIME	total_df_cancels	integer	R	R	
RUNTIME	total_df_sends	integer	R	R	
RUNTIME	total_df_receives	integer	R	R	
RUNTIME	total_df_transceives	integer	R	R	
RUNTIME	data_set_hangups	integer	R	R	
POOL	pool_coll_state	integer	R	R	
POOL	mss_process_total	integer	R	R	
POOL	mss_process_free	gauge	R	R	
POOL	mss_process_large	gauge	R	R	
POOL	mss_process_failed	integer	R	R	
POOL	mss_process_garbage	integer	R	R	
<b>Key to Access Modes</b>					
<b>R – Read Access</b>					
<b>RW – Read/Write Access</b>					
<b>Blank – Not available to the interface</b>					
<b>D – Field is dynamic</b>					

## 9.5.1. Field Descriptions

Following are descriptions of the fields in Table 9.4.

- record\_state

The current state of this table entry. Valid states are VALID (the process is currently running and maintaining this table entry) or INACTIVE (the process is no longer running). Inactive rows are subject to reuse.

- id\_coll\_state

The current collection state for this class and this process. Collection states can be modified by modifying entries in the Collection table. See Section 5.1 and Section 9.4 for discussions of data collection.

- process\_name

The OpenVMS process name for the process.

- user\_name

The OpenVMS account under which the process is running.

- pid

The OpenVMS process identifier for the process.

- start\_time

Date and time the process was started.

- end\_time

Date and time the process ended. If the process has not yet ended, this field is null.

- link\_time

Date and time the image was linked.

- runtime\_coll\_state

The current collection state for this class and this process. Collection states can be modified by modifying entries in the Collection table. See Section 5.1 and Section 9.4 for discussions of data collection.

If this field is set to DISABLED, the process is not currently collecting data for the fields in this class. Any field values reflect activity during a prior period when collection was enabled.

- acms\_state

The ACMS state of the process.

- decnet\_object

If the process has a current DECnet object, the value of this field is STARTED. Otherwise, the value is STOPPED. If the DECnet object is stopped (and the runtime\_coll\_state is enabled for this process), either distributed processing has not been enabled (that is, the node\_name parameter in

the ACMSGEN file is NULL) or there is currently a problem with DECnet. Also, check the ACC CONFIG parameters `node_name_active` and `node_name_stored` to determine the current status of the ACMSGEN `node_name` field.

- `current_attached_terminals`

The number of terminals currently attached to the CP.

- `active_task_calls`

The number of task calls currently being executed by all users of the CP.

- `active_tdms_menu_reqs`

The number of TDMS menu requests currently being executed by all users of the CP.

- `total_tdms_menu_reqs`

The total number of TDMS menu requests executed by all users of the CP since the CP was started.

- `active_tdms_reqs`

The number of TDMS requests of all types currently being executed by all users of the CP.

- `active_tdms_read_msgs`

The number of TDMS read messages currently being executed by all users of the CP.

- `active_tdms_write_msgs`

The number of TDMS write messages currently being executed by all users of the CP.

- `active_tdms_cancels`

The number of TDMS cancels currently being executed by all users of the CP.

- `total_tdms_reqs`

The total number of TDMS requests (menu and exchange) executed by all users of the CP since the CP was started.

- `total_tdms_read_msgs`

The total number of TDMS read messages executed by all users of the CP since the CP was started.

- `total_tdms_write_msgs`

The total number of TDMS write messages executed by all users of the CP since the CP was started.

- `total_tdms_cancels`

The total number of TDMS cancels executed by all users of the CP since the CP was started.

- `active_df_menu_reqs`

The number of DECforms menu requests currently being executed by all users of the CP.



- `total_df_menu_reqs`

The total number of DECforms menu requests executed by all users of the CP since the CP was started.

- `active_df_reqs`

The number of DECforms requests of all types currently being executed by all users of the CP.

- `active_df_enables`

The number of DECforms enable requests currently being executed by all users of the CP.

- `active_df_disables`

The number of DECforms disable requests currently being executed by all users of the CP.

- `active_df_cancels`

The number of DECforms cancel requests currently being executed by all users of the CP.

- `active_df_sends`

The number of DECforms requests currently being executed by all users of the CP.

- `active_df_receives`

The number of DECforms receive requests currently being executed by all users of the CP.

- `active_df_transceives`

The number of DECforms enable transceives currently being executed by all users of the CP.

- `total_df_reqs`

The total number of DECforms requests of all types executed by all users of the CP since the CP was started.

- `total_df_enables`

The total number of DECforms enable requests executed by all users of the CP since the CP was started.

- `total_df_disables`

The total number of DECforms disable requests executed by all users of the CP since the CP was started.

- `total_df_cancels`

The total number of DECforms cancel requests executed by all users of the CP since the CP was started.

- `total_df_sends`

The total number of DECforms send requests executed by all users of the CP since the CP was started.

- `total_df_receives`

The total number of DECforms receive requests executed by all users of the CP since the CP was started.

- `total_df_transceives`

The total number of DECforms transceive requests executed by all users of the CP since the CP was started.

- `data_set_hangups`

The total number of data set hangups detected by the CP since the CP was started.

- `pool_coll_state`

The current collection state for this class and this process. Collection states can be modified by modifying entries in the Collection table. See Section 9.4 and Section 5.1 for discussions of data collection.

If this field is set to `DISABLED`, the process is not currently collecting data for the fields in this class. Any field values reflect activity during a prior period when collection was enabled.

- `mss_process_total`

The total size of the MSS process pool allocated for this process. The frequency with which this field is updated is based on the value of the Parameter table field `mss_coll_interval` (see Table 9.8).

- `mss_process_free`

The amount of unused MSS process pool for this process. The frequency with which this field is updated is based on the value of the Parameter table field `mss_coll_interval` (see Table 9.8).

- `mss_process_largest`

The largest unused block available in the MSS process pool for this process. The frequency with which this field is updated is based on the value of the Parameter table field `mss_coll_interval` (see Table 9.8).

- `mss_process_failures`

The number of failed attempts to allocate space in the MSS process pool for this process. The frequency with which this field is updated is based on the value of the Parameter table field `mss_coll_interval` (see Table 9.8).

- `mss_process_garbage`

The number of garbage collections that have been run to reclaim space in this processes MSS process pool. The frequency with which this field is updated is based on the value of the Parameter table field `mss_coll_interval` (see Table 9.8).

## 9.6. EXC Table

The EXC table is sized according the `MAX_APPLS ACMSGEN` parameter.

**Table 9.5. EXC Table**

Collection Class	Field	Data Type	SNMP Access	RPC Access	Dynamic
ID	record_state	integer	R	R	
ID	id_coll_state	integer	R	R	
ID	process_name	string	R	R	
ID	user_name	string	R	R	
ID	pid	integer	R	R	
ID	start_time	time	R	R	
ID	end_time	time	R	R	
ID	appl_name	string	R	R	
ID	build_time	time	R	R	
ID	exc_appl_tbl_state	integer	R		
ID	exc_server_types	integer	R		
ID	exc_task_groups	integer	R		
CONFIG	config_coll_state	integer	R	R	
CONFIG	acms_state	integer	RW	R	D
CONFIG	audit_state_active	integer	RW	RW	D
CONFIG	audit_state_stored	integer	R	R	
CONFIG	max_tasks_active	integer	RW	RW	D
CONFIG	max_tasks_stored	integer	R	R	
CONFIG	sp_monitoring_active	integer	RW	RW	D
CONFIG	sp_monitoring_stored	integer	R	R	
CONFIG	max_servers_active	integer	RW	RW	D
CONFIG	max_servers_stored	integer	R	R	
CONFIG	transaction_time_active	integer	RW	RW	D
CONFIG	transaction_time_stored	integer	R	R	
RUNTIME	runtime_coll_state	integer	R	R	
RUNTIME	decnet_object	integer	R	R	
RUNTIME	current_servers	gauge	R	R	
RUNTIME	current_submitters	gauge	R	R	
RUNTIME	current_tasks	gauge	R	R	
RUNTIME	total_tasks_executed	integer	R	R	
RUNTIME	total_submitters	integer	R	R	
<b>Key to Access Modes</b>					
<b>R – Read Access</b>					
<b>RW – Read/Write Access</b>					
<b>Blank – Not available to the interface</b>					
<b>D – Field is dynamic</b>					

Collection Class	Field	Data Type	SNMP Access	RPC Access	Dynamic
RUNTIME	current_active_servers	gauge	R	R	
RUNTIME	current_free_servers	gauge	R	R	
RUNTIME	current_waiting_tasks	gauge	R	R	
RUNTIME	server_start_count	integer	R	R	
RUNTIME	server_failure_count	integer	R	R	
RUNTIME	task_failures	integer	R	R	
RUNTIME	task_start_failures	integer	R	R	
RUNTIME	task_security_failures	integer	R	R	
RUNTIME	task_cancels	integer	R	R	
RUNTIME	active_tdms_requests	gauge	R	R	
RUNTIME	active_tdms_read_messages	gauge	R	R	
RUNTIME	active_tdms_write_messages	gauge	R	R	
RUNTIME	active_tdms_cancels	gauge	R	R	
RUNTIME	total_tdms_requests	integer	R	R	
RUNTIME	total_tdms_read_messages	integer	R	R	
RUNTIME	total_tdms_write_messages	integer	R	R	
RUNTIME	total_tdms_cancels	integer	R	R	
RUNTIME	total_dataset_handles	integer	R	R	
POOL	pool_coll_state	integer	R	R	
POOL	mss_process_total	integer	R	R	
POOL	mss_process_free	min gauge	R	R	
POOL	mss_process_largest	min gauge	R	R	
POOL	mss_process_failures	integer	R	R	
POOL	mss_process_garbage	integer	R	R	
POOL	ws_pool_total	integer	R	R	
POOL	ws_pool_free	min gauge	R	R	
POOL	ws_pool_largest	min gauge	R	R	
POOL	ws_pool_failures	integer	R	R	
POOL	ws_pool_garbage	integer	R	R	
POOL	wsc_pool_total	integer	R	R	
POOL	wsc_pool_free	min gauge	R	R	
POOL	wsc_pool_largest	min gauge	R	R	
<b>Key to Access Modes</b>					
<b>R – Read Access</b>					
<b>RW – Read/Write Access</b>					
<b>Blank – Not available to the interface</b>					
<b>D – Field is dynamic</b>					

Collection Class	Field	Data Type	SNMP Access	RPC Access	Dynamic
POOL	wsc_pool_failures	integer	R	R	
POOL	wsc_pool_garbage	integer	R	R	
POOL	twsc_pool_total	integer	R	R	
POOL	twsc_pool_total	integer	R	R	
<b>Key to Access Modes</b> <b>R – Read Access</b> <b>RW – Read/Write Access</b> <b>Blank – Not available to the interface</b> <b>D – Field is dynamic</b>					

## 9.6.1. Field Descriptions

Following are descriptions of the fields in Table 9.5.

- record\_state

The current state of this table entry. Valid states are VALID (the process is currently running and maintaining this table entry) or INACTIVE (the process is no longer running). Inactive rows are subject to reuse.

- id\_coll\_state

The current collection state for this class and this process. Collection states can be modified by modifying entries in the Collection table. See Section 5.1 and Section 9.4 for discussions of data collection.

- process\_name

The OpenVMS process name for the process.

- user\_name

The OpenVMS account under which the process is running.

- pid

The OpenVMS process identifier of the process.

- start\_time

Date and time the process was started.

- end\_time

Date and time the process ended. If the process has not yet ended, this field will be null.

- appl\_name

Name of the application.

- `build_time`

Date and time the application database (ADB) was built.

- `exc_appl_tbl_state`

This field is available to the SNMP interface only. It contains the state of the application global section for this EXC. When EXCs have completed their startup, they construct global sections containing server and task group tables. If this field is not `MGMT$K_VALID (2)`, the Server and Task Group tables are not available.

- `exc_server_types`

This field is available to the SNMP interface only. It contains the number of server types contained in the application, which is also the number of rows in the Server table for this EXC.

- `exc_task_groups`

This field is available to the SNMP interface only. It contains the number of task groups contained in the application, which is also the number of rows in the Task Group table for this EXC.

- `config_coll_state`

The current collection state for this class and this process. Collection states can be modified by modifying entries in the Collection table. See Section 5.1 and Section 9.4 for discussions of data collection.

- `audit_state_active`

Current auditing state of the application.

- `audit_state_stored`

Value of the auditing state of the application as specified in the ACMS application database (.ADB file).

- `max_tasks_active`

The current maximum number of executing tasks allowed.

- `max_tasks_stored`

The maximum number of executing tasks allowed as specified in the ACMS application database (.ADB file).

- `sp_monitoring_interval_active`

The current server process monitoring interval for the application.

- `sp_monitoring_interval_stored`

The server process monitoring interval for the application as specified in the ACMS application database (.ADB file).

- `max_servers_active`

The current maximum number of started server instances for the application.

- `max_servers_stored`

The maximum number of started server instances for the application as specified in the ACMS application database (.ADB file).

- `transaction_timeout_active`

The current default task timeout for the application.

- `transaction_timeout_stored`

The default task timeout for the application as specified in the ACMS application database (.ADB file).

- `acms_state`

The current ACMS state of this process.

- `runtime_coll_state`

The current collection state for this class and this process. Collection states can be modified by modifying entries in the Collection table. See Section 5.1 and Section 9.4 for discussions of data collection.

If this field is set to `DISABLED`, the process is not currently collecting data for the fields in this class. Any field values reflect activity during a prior period when collection was enabled.

- `decnet_object`

If the process has a current DECnet object, the value of this field is `STARTED`. Otherwise, the value is `STOPPED`. If the DECnet object is stopped (and the `runtime_coll_state` is enabled for this process), either distributed processing has not been enabled (that is, the `node_name` parameter in the `ACMSGGEN` file is `NULL`) or there is currently a problem with DECnet. Also, check the `ACC CONFIG` parameters `node_name_active` and `node_name_stored` to determine the current status of the `ACMSGGEN` `node_name` field.

- `current_servers`

The number of server instances currently started in this application.

- `current_submitters`

The number of submitters currently logged in to this application.

- `current_tasks`

The number of tasks currently started in the application.

- `total_tasks_executed`

The total number of tasks started in the application since the application was started.

- `total_submitters`

The total number of submitters who have submitted tasks to this application since the application was started.

- `current_active_servers`

The current number of active servers (that is, those servers performing processing steps).

- `current_free_servers`

The number of started servers which are not currently active (that is, not currently executing processing steps).

- `current_waiting_tasks`

The number of tasks that are not executing, waiting for a procedure server to become available.

- `server_start_count`

The number of times servers have been started in this application.

- `server_failure_count`

The number of times servers have been stopped in this application.

- `task_failures`

The number of tasks in this application that have failed to complete successfully.

- `task_start_failures`

The number of tasks in this application that have failed to start.

- `task_security_failures`

The number of tasks in this application that have failed to start because of security violations.

- `task_cancels`

The number of tasks in this application that have been cancelled.

- `active_tdms_requests`

The number of TDMS requests (both exchange and menu) that are currently executing for this process.

- `active_tdms_read_messages`

The number of TDMS read messages currently outstanding for this process.

- `active_tdms_write_messages`

The number of TDMS write messages currently outstanding for this process.

- `active_tdms_cancels`

The number of TDMS cancels currently outstanding for this process.



- `total_tdms_requests`

The total number of TDMS requests (both exchange and menu) processed by this process while the `runtime_coll_state` has been ENABLED.

- `total_tdms_read_messages`

The total number of TDMS read messages processed by this process while the `runtime_coll_state` has been ENABLED.

- `total_tdms_write_messages`

The total number of TDMS write messages processed by this process while the `runtime_coll_state` has been ENABLED.

- `total_tdms_cancels`

The total number of TDMS cancels processed by this process while the `runtime_coll_state` has been ENABLED.

- `total_dataset_hangups`

The total number of TDMS dataset hangups (unexpected session interruptions) processed by this process while the `runtime_coll_state` has been ENABLED.

- `pool_coll_state`

The current collection state for this class and this process. Collection states can be modified by modifying entries in the Collection table. See Section 5.1 and Section 9.4 for discussions of data collection.

If this field is set to DISABLED, the process is not currently collecting data for the fields in this class. Any field values reflect activity during a prior period when collection was enabled.

- `mss_process_total`

The total size of the MSS process pool allocated for this process. The frequency with which this field is updated is based on the value of the Parameter table field `mss_coll_interval` (see Table 9.8).

- `mss_process_free`

The amount of unused MSS process pool for this process. The frequency with which this field is updated is based on the value of the Parameter table field `mss_coll_interval` (see Table 9.8).

- `mss_process_largest`

The largest unused block available in the MSS process pool for this process. The frequency with which this field is updated is based on the value of the Parameter table field `mss_coll_interval` (see Table 9.8).

- `mss_process_failures`

The number of failed attempts to allocate space in the MSS process pool for this process. The frequency with which this field is updated is based on the value of the Parameter table field `mss_coll_interval` (see Table 9.8).

- `mss_process_garbage`

The number of garbage collections for this process that have been run to reclaim space in the MSS process pool for this process. The frequency with which this field is updated is based on the value of the Parameter table field `mss_coll_interval` (see Table 9.8).

- `ws_pool_total`

The total size of the WS pool allocated for this application. The frequency with which this field is updated is based on the value of the Parameter table field `wksp_coll_interval` (see Table 9.8).

- `ws_pool_free`

The amount of unused WS pool for this application. The frequency with which this field is updated is based on the value of the Parameter table field `wksp_coll_interval` (see Table 9.8).

- `ws_pool_largest`

The largest unused block available in this application's WS pool. The frequency with which this field is updated is based on the value of the Parameter table field `wksp_coll_interval` (see Table 9.8).

- `ws_pool_failures`

The number of failed attempts to allocate space in the WS pool for this application. The frequency with which this field is updated is based on the value of the Parameter table field `wksp_coll_interval` (see Table 9.8).

- `ws_pool_garbage`

The number of garbage collections that have been run to reclaim space in this application's WS pool. The frequency with which this field is updated is based on the value of the Parameter table field `wksp_coll_interval` (see Table 9.8).

- `wsc_pool_total`

The total size of the WSC pool allocated for this application. The frequency with which this field is updated is based on the value of the Parameter table field `wksp_coll_interval` (see Table 9.8).

- `wsc_pool_free`

The amount of unused WSC pool for this application. The frequency with which this field is updated is based on the value of the Parameter table field `wksp_coll_interval` (see Table 9.8).

- `wsc_pool_largest`

The largest unused block available in this application's WSC pool. The frequency with which this field is updated is based on the value of the Parameter table field `wksp_coll_interval` (see Table 9.8).

- `wsc_pool_failures`

The number of failed attempts to allocate space in this application's WSC pool. The frequency with which this field is updated is based on the value of the Parameter table field `wksp_coll_interval` (see Table 9.8).

- `wsc_pool_garbage`

The number of garbage collections that have been run to reclaim space in this application's WSC pool. The frequency with which this field is updated is based on the value of the Parameter table field `wksp_coll_interval` (see Table 9.8).

- `twsp_pool_total`

The default size for TWS pools (in pagelets) allocated for this application.

- `twsc_pool_total`

The default size for TWSC pools (in pagelets) allocated for this application.

## 9.7. Interfaces Table

The Interfaces table is populated from the configuration file by the ACMS Remote Manager process during process startup. This table specifies which interfaces are active and contains parameters associated with each interface. By default, the RPC interface is started; SNMP is not started.

**Table 9.6. Interfaces Table**

Field	Data Type	SNMP Access	RPC Access	Configuration Access	Dynamic
<code>interface</code>	string	R	R	R	
<code>state</code>	state1	RW	RW	RW	D
<code>running_state</code>	state2	R	R	R	
<code>get_request_count</code>	integer	R	R		
<code>set_request_count</code>	integer	R	R		
<code>alarms_sent</code>	integer	R	R		
<code>time_alarm_last</code>	integer	R	R		
<b>Key to Access Modes</b>  <b>R – Read Access</b> <b>RW – Read/Write Access</b> <b>Blank – Not available to the interface</b> <b>D – Field is dynamic.</b>					

### 9.7.1. Field Descriptions

Following are descriptions of the fields in Table 9.6.

- `interface`

Name or type of the interface. Valid values are RPC or SNMP.

- `state`

Current state as configured, either from the configuration file or by a user at run time. Valid values are ENABLED or DISABLED. Note that state and `acms_state` are not always the same because of potential run-time failures in a thread. For instance, if a thread fails to start, state may be ENABLED, but `acms_state` may be STOPPED.

A thread can be enabled only if the `acms_state` value is STOPPED. A thread can be disabled only if the `acms_state` value is not STOPPED.

- `acms_state`

Actual execution state. Interfaces go through the following states:

- INITING

The Remote Manager is in the process of creating the interface thread.

- STARTING

The interface thread has been created and is initializing.

- STARTED

The interface thread has completed initializing and is now running.

- STOPPING

The thread is starting shutdown, as the result of either a stop request or a fatal error.

- STOPPED

The thread is no longer executing.

- `get_request_count`

The number of read requests submitted to the interface. This includes requests that are rejected because of authorization failures.

- `set_request_count`

The number of write requests submitted to the interface. This includes requests that are rejected because of authorization failures.

- `alarms_sent`

The number of alarms that have been sent by this interface. For SNMP, these are SNMP traps. For RPC, this field is undefined.

- `time_alarm_last_sent`

The time the most recent alarm was sent by this interface. For SNMP, this is the time the last SNMP trap was sent. For RPC, this field is undefined.

## 9.8. Manager Status Table

The Manager Status table contains run-time values that reflect Remote Manager activity. This table is maintained internally by the Remote Manager and is read only to all external entities. Values in the table can be accessed through one of the supported interfaces. No changes can be made to the table by external users.

In general, the values in this table are informational only.

**Table 9.7. Manager Status Table**

Field Name	Data Type	SNMP Access	RPC Access	Dynamic
collection_count	integer	R	R	
interfaces_count	integer	R	R	
timer_count	integer	R	R	
trap_count	integer	R	R	
rpc_udp_state	state1	R	R	
rpc_tcp_state	state1	R	R	
<b>Key to Access Modes</b>				
<b>R – Read Access</b>				
<b>RW – Read/Write Access</b>				
<b>Blank – Not available to the interface</b>				
<b>D – Field is dynamic</b>				

## 9.8.1. Field Descriptions

Following are descriptions of the fields in Table 9.7.

- collection\_count  
Current number of Collection table entries.
- interfaces\_count  
Current number of entries in the Interfaces table.
- timer\_count  
Current number of entries in the Timer table.
- trap\_count  
Current number of entries in the Trap table.
- rpc\_udp\_state  
Current state of the RPC interface using the UDP protocol. A value of 1 means that the UDP protocol is active. A value of 0 means that the UDP protocol is inactive.
- rpc\_tcp\_state  
Current state of the RPC interface using the TCP protocol. A value of 1 means that the UDP protocol is active. A value of 0 means that the UDP protocol is inactive.

## 9.9. Parameter Table

The Parameter table contains values that control the operation of the ACMS Remote Manager and that are not directly related to any ACMS entity. This table is populated initially from the ACMSCFG file. The Remote Manager maintains the table internally at run time; users can access data in the table only through one of the supported interfaces. Changes made to the table at run time are lost when the Remote Manager is stopped.

In general, the values in this table should be modified for fine tuning only, and only if a demonstrated need exists.

## Note

All the fields in Table 9.8 are of type integer, and all fields have read and write access.

**Table 9.8. Parameter Table**

Field	Default Value	Minimum Value	Maximum Value	Dynamic	Interface
dcl_audit_level	E	0	F	D	S,R,F
dcl_mgr_priority	5	1	10		S,R,F
dcl_stacksize	300	1	2147483647		S,R,F
event_log_priority	5	1	10		S,R,F
log_stacksize	300	1	2147483647		S,R,F
login_creds_lifetime	60s	1	14399999	D	S,R,F
max_logins	20	1	2147483647	D	S,R,F
max_rpc_return_time	20s	1	2147483647		S,R,F
mgr_audit_level	E	0	F	D	S,R,F
msg_proc_audit_level	E	0	F	D	S,R,F
msg_proc_priority	5	1	10		S,R,F
msg_proc_stacksize	300	1	2147483647		S,R,F
mss_coll_interval	10	1	863999999	D	S,R,F
proc_mon_audit_level	E	0	F		S,R,F
proc_mon_interval	10	1	14399999	D	S,R,F
proc_mon_priority	5	1	10		S,R,F
proc_mon_stacksize	300	1	2147483647		S,R,F
proxy_creds_lifetime	60s	1	14399999	D	S,R,F
rpc_audit_level	E	0	F	D	S,R,F
rpc_priority	5	1	10		S,R,F
rpc_stacksize	300	1	2147483647		S,R,F
security_audit_level	E	0	F	D	S,R,F
snmp_agent_timeout	10	1	863999999	D	S,R,F
snmp_audit_level	E	0	F	D	S,R,F
snmp_are_you_there	300	1	863999999		S,R,F
snmp_priority	5	1	10		S,R,F

### Key to Interface

**S** – SNMP

**R** – RPC (API and ACM SMGR utility)

**F** – File (configuration file)

**D** – Field is dynamic.

Field	Default Value	Minimum Value	Maximum Value	Dynamic	Interface
snmp_sel_time_out	30	0	863999999		S,R,F
snmp_stacksize	300	1	2147483647		S,R,F
timer_audit_level	E	0	F	D	S,R,F
timer_interval	30	1	863999999	D	S,R,F
timer_priority	5	1	10		S,R,F
timer_stacksize	300	1	2147483647		S,R,F
total_entity_slots	20	1	2147483647		S,R,F
trace_msg_wait_time	5	1	14399999	D	S,R,F
trace_start_wait_time	5	1	14399999	D	S,R,F
trap_audit_level	E	0	F	D	S,R,F
trap_priority	5	1	10		S,R,F
trap_stacksize	300	1	2147483647		S,R,F
wksp_coll_interval	10	1	863999999	D	S,R,F
<b>Key to Interface</b>					
S – SNMP					
R – RPC (API and ACMSMGR utility)					
F – File (configuration file)					
D – Field is dynamic.					

## 9.9.1. Field Descriptions

Following are descriptions of the fields in Table 9.8.

- dcl\_audit\_level, mgr\_audit\_level, msg\_audit\_level, proc\_mon\_audit\_level, rpc\_audit\_level, security\_audit\_level, snmp\_audit\_level, timer\_audit\_level, trap\_audit\_level

Audit levels determine the amount of auditing information written for a given facility. Audit levels are specified using a hexadecimal value from 0 (none) to F (all). The integer values are a logical ORing of the following:

INFO	1
WARN	2
ERROR	4
FATAL	8

For example, to specify auditing of both error and fatal information, specify a value of C. For more information about auditing and audit levels see Section 4.7.

- dcl\_mgr\_priority

Relative priority of the DCL manager thread. The DCL manager is used to send ACMS run-time changes to the ACMS system. Priority is specified as a whole number between 1 and 10, where 1 is the lowest priority and 10 is the highest. This value should be left at the default.

- `dcl_stacksize`, `log_stacksize`, `msg_proc_stacksize`, `proc_mon_stacksize`, `rpc_stacksize`, `snmp_stacksize`, `timer_stacksize`, `trap_stacksize`,

These values determine the internal stack sizes for each thread. Stack sizes are set during thread creation and are not adjusted after the thread has been started. Restartable threads, such as RPC and SNMP, can be adjusted while the Remote Manager is running by disabling the interface, modifying the parameter, and then reenabling the interface.

- `event_log_priority`

Relative priority of the event log thread. The event log thread writes audit messages to the audit log. Priority is specified as a whole number between 1 and 10, where 1 is the lowest priority and 10 is the highest. This value should be left at the default.

- `login_creds_lifetime`

The amount of time (in minutes) that explicit logins are valid. When a user logs in to a Remote Manager process using a valid OpenVMS account and password, a login is created for the user, and the expiration of that login is calculated and stored based on this parameter. When the current time is greater than the expiration time, the user is logged out and must log in again using the ACMSMGR LOGIN command. A change to this parameter takes effect for any login that takes place after the change is made. A change to this parameter does not take effect for any login that took place before the change was made.

- `max_logins`

Maximum number of external processes allowed to concurrently connect to the Remote Manager. Starting the SNMP interface counts as one login. Each RPC client counts as one login. RPCs are serviced serially.

- `max_rpc_return_recs`

The maximum number of records to be returned to any given request for data. This parameter allows network bandwidth to be conserved by sending data in user-managed chunks.

- `msg_proc_priority`

Relative priority of the message processor thread. The message processor is responsible for removing messages sent by ACMS processes to the Remote Manager from the error input queue and for processing messages according to configuration values specified in the Collection and Trap tables. This value should be left at the default. Priority is specified as a whole number between 1 and 10, where 1 is the lowest priority and 10 is the highest.

- `mss_coll_interval`

Controls the frequency (in seconds) at which MSS values are collected. A lower value causes MSS values to be collected more often; a higher value causes MSS values to be collected less often. MSS values are collected by all ACMS run-time processes except SWL, ATR, and procedure servers.

- `proc_mon_interval`

The frequency (in seconds) at which the process monitor thread should run. The process monitor thread checks for the existence of the ACC and other ACMS run-time processes in order to map the MGMT global section and to send alarms.



- `proc_mon_priority`

Relative priority of the process monitor thread. The process monitor thread periodically checks for the existence of the ACC process in order to map the MGMT global section and to send alarms. Priority is specified as a whole number between 1 and 10, where 1 is the lowest priority and 10 is the highest. This value should be left at the default.

- `proxy_creds_lifetime`

The amount of time (in minutes) that proxy logins are valid. When a user first accesses a Remote Manager process using an ACMS proxy, a login is created for the user, and the expiration of that login is calculated and stored based on this parameter. When the current time is greater than the expiration time, the user's proxy information is refreshed. A change to this parameter takes effect for any login that takes place after the change is made. A change to this parameter does not take effect for any login that took place before the change was made.

- `rpc_priority`

Relative priority of the RPC management thread. The RPC management thread responds to RPC requests to get or set data values. Priority is specified as a whole number between 1 and 10, where 1 is the lowest priority and 10 is the highest.

- `snmp_agent_time_out`

Number of seconds that the SNMP Master agent waits for a response from the Remote Manager. The maximum is 10 seconds for Compaq TCP/IP Services Version 4.2. For Compaq TCP/IP Services Version 5.0 and higher, the maximum is 60 seconds.

- `snmp_are_you_there`

Controls how often are you there messages are sent by the Remote Manager to the SNMP Master agent. This value should be entered as a multiple of the `snmp_sel_time_out` value. Each time a timeout occurs, a timeout counter is incremented. The product of the timeout counter and the `snmp_sel_timeout` are then compared to the `snmp_are_you_there` value. If the product is greater than the `snmp_are_you_there` value, an `are_you_there` message is sent.

- `snmp_priority`

Relative priority of the SNMP management thread. The SNMP management thread responds to SNMP requests to get or set data values. Priority is specified as a whole number between 1 and 10, where 1 is the lowest and 10 is the highest.

- `snmp_sel_time_out`

Controls how long the Remote Manager waits for a response from the SNMP master agent. If the timeout value is reached and no messages are expected, the `snmp_are_you_there` interval is checked (see `snmp_are_you_there`). If a message is expected and is not received before the select times out, the connection to the master agent is assumed to have been lost and an attempt is made to reregister. There is a hard coded 2 second wait prior to reregistration.

This value also controls how long it takes to begin disabling this interface. Requests to disable the interface do not interrupt the socket select – they wait for it to either timeout or end naturally (that is, when a message is received). At worst case, a request to disable the interface has to wait `snmp_sel_time_out` seconds before the shutdown of the interface begins. Once it begins, it usually shuts down quickly – within a second or two.

- `timer_interval`

The Remote Manager runs one internal timer that controls the operation of all other timers. The interval of this timer effectively sets the smallest timer interval for the process. The interval is set in seconds. If the value is too small, the timer will run frequently with no work to do. This value should be set to smallest desired timer interval.

- `timer_priority`

Relative priority of the timer thread. The timer thread manages all internal timers. Priority is specified as a whole number between 1 and 10, where 1 is the lowest priority and 10 is the highest. This value should be left at the default.

- `total_entity_slots`

The total number of Collection table entries to allow. When this number is reached, additional ACMSMGR ADD COLLECTION requests are rejected. Slots are allocated when the ACMS runtime system is started.

- `trace_msg_wait_time`

The number of seconds the Remote Manager should wait for updates to the `mss_coll_interval` and `wksp_coll_interval` parameters to become effective (processed by the ACC). Updates to the ACC are sent by means of the trace monitor. The Remote Manager will poll the value being changed for up to `trace_msg_wait_time` seconds to see whether the value was in fact changed. If it is not changed within this timeframe, the Remote Manager logs an error and returns an error to the caller.

- `trace_start_wait_time`

The number of seconds the Remote Manager should wait for the trace monitor to be started. The Remote Manager communicates to ACMS process through the trace monitor. The Remote Manager attempts to start the trace monitor if the Remote Manager needs to send a message and the trace monitor is not already running. This value controls how long the Remote Manager will wait for the trace monitor to start before aborting the message send. Messages that are not sent are discarded (lost).

- `trap_priority`

Relative priority of the trap sender thread. The trap sender thread dispatches trap messages to SNMP and RPC receivers. Priority is specified as a whole number between 1 and 10, where 1 is the lowest priority and 10 is the highest. This value should be left at the default.

- `wksp_coll_interval`

Controls the frequency (in seconds) at which workspace (WS, WSC, TWS, TWSC) pool values are collected. A lower value causes workspace values to be collected more often; a higher value causes workspace pool values to be collected less often. Workspace pool values are collected only by ACC and EXC.

## 9.10. QTI Table

The QTI table contains a single entry for QTI management information.

**Table 9.9. QTI Table**

Collection Class	Field	Data Type	SNMP Access	RPC Access	Dynamic
ID	record_state	integer	R	R	
ID	id_coll_state	integer	R	R	
ID	process_name	string	R	R	
ID	pid	integer	R	R	
ID	start_time	time	R	R	
ID	end_time	time	R	R	
CONFIG	config_coll_state	integer	R	R	
CONFIG	acms_state	integer	RW	R	D
CONFIG	qti_username_active	string	R	R	
CONFIG	qti_username_store	string	RW	RW	
CONFIG	qti_priority_active	integer	R	R	
CONFIG	qti_priority_store	integer	RW	RW	
CONFIG	max_threads	integer	RW	RW	
CONFIG	sub_timeout_active	integer	RW	RW	D
CONFIG	sub_timeout_store	integer	RW	RW	
CONFIG	retry_timer_active	integer	RW	RW	D
CONFIG	retry_timer_store	integer	RW	RW	
CONFIG	polling_timer_active	integer	RW	RW	D
CONFIG	polling_timer_store	integer	RW	RW	
RUNTIME	runtime_coll_state	integer	R	R	
RUNTIME	started_queues	gauge	R	R	
RUNTIME	current_tasks	gauge	R	R	
RUNTIME	current_submitters	gauge	R	R	
RUNTIME	task_successes	integer	R	R	
RUNTIME	task_failures	integer	R	R	
RUNTIME	task_retries	integer	R	R	
RUNTIME	errors_queued	integer	R	R	
POOL	pool_coll_state	integer	R	R	
POOL	mss_process_total	integer	R	R	
POOL	mss_process_free	min gauge	R	R	
POOL	mss_process_large	min gauge	R	R	
<b>Key to Access Modes</b>					
<b>R – Read Access</b>					
<b>RW – Read/Write Access</b>					
<b>Blank – Not available to the interface</b>					
<b>D – Field is dynamic.</b>					

Collection Class	Field	Data Type	SNMP Access	RPC Access	Dynamic
POOL	mss_process_failures	integer	R	R	
POOL	mss_process_garbage	integer	R	R	
<b>Key to Access Modes</b>  <b>R – Read Access</b> <b>RW – Read/Write Access</b> <b>Blank – Not available to the interface</b> <b>D – Field is dynamic.</b>					

## 9.10.1. Field Descriptions

Following are descriptions of the fields in Table 9.9.

- record\_state  

The current state of this table entry. Valid states are VALID (the process is currently running and maintaining this table entry) or INACTIVE (the process is no longer running). Inactive rows are subject to reuse.
- id\_coll\_state  

The current collection state for this class and this process. Collection states can be modified by modifying entries in the Collection table. See Section 5.1 and Section 9.4 for discussions of data collection.
- process\_name  

The OpenVMS process name for the process.
- pid  

The OpenVMS process identifier for the process.
- start\_time  

Date and time the process was started.
- end\_time  

Date and time the process ended. If the process has not yet ended, this field will be null.
- config\_coll\_state  

The current collection state for this class and this process. Collection states can be modified by modifying entries in the Collection table. See Section 5.1 and Section 9.4 for discussions of data collection.
- qti\_username\_active  

The OpenVMS account under which the QTI will run. This is the value of the ACMSGEN field when the process was started.
- qti\_username\_stored

The value of the `qti_username` field currently stored in the ACMSGEN file.

- `qti_priority_active`

The base priority for this process. This is the value of the ACMSGEN field when the process was started.

- `qti_priority_stored`

The base priority currently stored in the ACMSGEN file for this process.

- `max_threads`

The maximum number of threads allowed.

- `sub_timeout_active`

The current value of the QTI submitter timeout.

- `sub_timeout_stored`

The value of the `qti_sub_timeout` field in the current ACMSGEN file.

- `retry_timer_active`

The current value of the QTI retry timer.

- `retry_timer_stored`

The value of the `qti_retry_timer` field in the current ACMSGEN file.

- `polling_timer_active`

The current value of the QTI polling timer.

- `polling_timer_stored`

The value of the `qti_polling_timer` field in the current ACMSGEN file.

- `acms_state`

The current ACMS state of this process.

- `runtime_coll_state`

The current collection state for this class and this process. Collection states can be modified by modifying entries in the Collection table. See Section 5.1 and Section 9.4 for discussions of data collection.

If this field is set to `DISABLED`, the process is not currently collecting data for the fields in this class. Any field values reflect activity during a prior period when collection was enabled.

- `started_queues`

The number of queues currently started on the node.

- `current_tasks`

The number of tasks currently executed that were submitted by the QTI.

- `current_submitters`

The number of submitters currently logged in by the QTI.

- `task_successes`

The number of tasks successfully submitted and executed by the QTI.

- `task_failures`

The number of tasks that failed to complete successfully after being submitted by the QTI.

- `task_retries`

The number of times the QTI has attempted to re-run a task that is currently failed.

- `errors_queued`

The number of tasks queued to error queues by the QTI.

- `pool_coll_state`

The current collection state for this class and this process. Collection states can be modified by modifying entries in the Collection table. See Section 5.1 and Section 9.4 for discussions of data collection.

If this field is set to `DISABLED`, the process is not currently collecting data for the fields in this class. Any field values reflect activity during a prior period when collection was enabled.

- `mss_process_total`

The total size of the MSS process pool allocated for this process. The frequency with which this field is updated is based on the value of the Parameter table field `mss_coll_interval` (see Table 9.8).

- `mss_process_free`

The amount of MSS process pool for this process that is currently unused. The frequency with which this field is updated is based on the value of the Parameter table field `mss_coll_interval` (see Table 9.8).

- `mss_process_largest`

The largest unused block available in the MSS process pool for this process. The frequency with which this field is updated is based on the value of the Parameter table field `mss_coll_interval` (see Table 9.8).

- `mss_process_failures`

The number of failed attempts to allocate space in the MSS process pool for this process. The frequency with which this field is updated is based on the value of the Parameter table field `mss_coll_interval` (see Table 9.8).

- `mss_process_garbage`

The number of garbage collections for this process that have been run to reclaim space in the MSS process pool. The frequency with which this field is updated is based on the value of the Parameter table field `mss_coll_interval` (see Table 9.8).

## 9.11. Server Table

The Server table contains a separate row for each server type (not server instance) in the application. Totals are for all instances of the server type.

**Table 9.10. Server Table**

Collection Class	Field	Data Type	SNMP Access	RPC Access	Dynamic
ID	<code>record_state</code>	integer	R	R	
ID	<code>id_coll_state</code>	integer	R	R	
ID	<code>appl_name</code>	string	R	R	
ID	<code>server_name</code>	string	R	R	
CONFIG	<code>config_coll_state</code>	integer	R	R	
CONFIG	<code>creation_delay</code>	integer	RW	RW	D
CONFIG	<code>creation_interval</code>	integer	RW	RW	D
CONFIG	<code>deletion_delay</code>	integer	RW	RW	D
CONFIG	<code>deletion_interval</code>	integer	RW	RW	D
CONFIG	<code>server_process_diagnostics</code>	integer	RW	RW	D
CONFIG	<code>server_replace_flag</code>	integer	RW	RW	D
CONFIG	<code>minimum_instances</code>	integer	RW	RW	D
CONFIG	<code>maximum_instances</code>	integer	RW	RW	D
RUNTIME	<code>runtime_coll_state</code>	integer	R	R	
RUNTIME	<code>current_servers</code>	gauge	R	R	
RUNTIME	<code>current_waiting tasks</code>	gauge	R	R	
RUNTIME	<code>server_start_count</code>	integer	R	R	
RUNTIME	<code>server_failures</code>	integer	R	R	
<b>Key to Access Modes</b>					
R – Read Access					
RW – Read/Write Access					
Blank – Not available to the interface					
D – Field is dynamic.					

### 9.11.1. Field Descriptions

Following are descriptions of the fields in Table 9.10.

- `record_state`

The current state of this table entry. Valid states are VALID (the process is currently running and maintaining this table entry) or INACTIVE (the process is no longer running). Inactive rows are subject to reuse.

- `id_coll_state`

The current collection state for this class and this process. Collection states can be modified by modifying entries in the Collection table. See Section 5.1 and Section 9.4 for discussions of data collection.

- `appl_name`

Name of the application to which this server type belongs.

- `server_name`

Name of this server type.

- `config_coll_state`

The current collection state for this class and this process. Collection states can be modified by modifying entries in the Collection table. See Section 5.1 and Section 9.4 for discussions of data collection.

- `creation_delay_active`

The current creation delay for this server type.

- `creation_interval_active`

The current creation interval for this server type.

- `deletion_delay_active`

The current deletion delay for this server type.

- `deletion_interval_active`

The current deletion interval for this server type.

- `server_process_dump_flag_active`

The current server process dump flag for this server type.

- `server_replace_flag`

This field provides the ability for SNMP users to replace a server type by setting this value to 1. This field is available only to the SNMP interface.

- `minimum_instances_active`

The current minimum number of started instances for this server type.

- `maximum_instances_active`

The current maximum number of started instances for this server type.



- runtime\_coll\_state

The current collection state for this class and this process. Collection states can be modified by modifying entries in the Collection table. See Section 5.1 and Section 9.4 for discussions of data collection.

If this field is set to DISABLED, the process is not currently collecting data for the fields in this class. Any field values reflect activity during a prior period when collection was enabled.

- current\_servers

The current number of started servers of this type in the application.

- current\_waiting\_tasks

The current number of tasks waiting to execute processing steps that call servers of this type in this application.

- server\_start\_count

The number of times a server instance has been created for servers of this type in this application.

## 9.12. Task Group Table

The Task Group table contains a row for each task group in the application.

**Table 9.11. Task Group Table**

Collection Class	Field	Data Type	SNMP Access	RPC Access	Dynamic
ID	record_state	integer	R	R	
ID	id_coll_state	integer	R	R	
ID	appl_name	string	R	R	
ID	task_group_name	string	R	R	
ID	build_time	time	R	R	
POOL	pool_coll_state	integer	R	R	
POOL	twc_pool_total	integer	R	R	
POOL	twc_pool_free	min gauge	R	R	
POOL	twc_pool_largest	min gauge	R	R	
POOL	twc_pool_failures	integer	R	R	
POOL	twc_pool_garbage	integer	R	R	
POOL	twsc_pool_total	integer	R	R	
POOL	twsc_pool_free	min gauge	R	R	
<b>Key to Access Modes</b>					
<b>R – Read Access</b>					
<b>RW – Read/Write Access</b>					
<b>Blank – Not available to the interface</b>					
<b>D – Field is dynamic</b>					

Collection Class	Field	Data Type	SNMP Access	RPC Access	Dynamic
POOL	twsc_pool_largest	min gauge	R	R	
POOL	twsc_pool_failures	integer	R	R	
POOL	twsc_pool_garbage	integer	R	R	
<b>Key to Access Modes</b>  <b>R – Read Access</b> <b>RW – Read/Write Access</b> <b>Blank – Not available to the interface</b> <b>D – Field is dynamic</b>					

## 9.12.1. Field Descriptions

Following are descriptions of the fields in Table 9.11.

- record\_state

The current state of this table entry. Valid states are VALID (the process is currently running and maintaining this table entry) or INACTIVE (the process is no longer running). Inactive rows are subject to reuse.

- id\_coll\_state

The current collection state for this class and this process. Collection states can be modified by modifying entries in the Collection table. See Section 5.1 and Section 9.4 for discussions of data collection.

- appl\_name

Name of the application to which this server type belongs.

- task\_group\_name

Name of this task group.

- build\_time

The date and time the task group database (TDB) was built.

- pool\_coll\_state

The current collection state for this class and this process. Collection states can be modified by modifying entries in the Collection table. See Section 5.1 and Section 9.4 for discussions of data collection.

If this field is set to DISABLED, the process is not currently collecting data for the fields in this class. Any field values reflect activity during a prior period when collection was enabled.

- twsc\_pool\_total

The total size of the TWS pool allocated for this task group. The frequency with which this field is updated is based on the value of the Parameter table field wksp\_coll\_interval (see Table 9.8).

- twsc\_pool\_free

The amount of unused TWS pool this task group. The frequency with which this field is updated is based on the value of the Parameter table field `wksp_coll_interval` (see Table 9.8).

- `twsp_pool_largest`

The largest unused block available in this task group's TWS pool. The frequency with which this field is updated is based on the value of the Parameter table field `wksp_coll_interval` (see Table 9.8).

- `twsp_pool_failures`

The number of failed attempts to allocate space in the TWS pool for this task group, The frequency with which this field is updated is based on the value of the Parameter table field `wksp_coll_interval` (see Table 9.8).

- `twsp_pool_garbage`

The number of garbage collections that have been run to reclaim space in this task group's TWS pool. The frequency with which this field is updated is based on the value of the Parameter table field `wksp_coll_interval` (see Table 9.8).

- `twsc_pool_total`

The total size of the TWSC pool allocated for this task group. The frequency with which this field is updated is based on the value of the Parameter table field `wksp_coll_interval` (see Table 9.8).

- `twsc_pool_free`

The amount of unused TWSC Pool for this task group. The frequency with which this field is updated is based on the value of the Parameter table field `wksp_coll_interval` (see Table 9.8).

- `twsc_pool_largest`

The largest unused block available in this task group's TWSC pool. The frequency with which this field is updated is based on the value of the Parameter table field `wksp_coll_interval` (see Table 9.8).

- `twsc_pool_failures`

The number of failed attempts to allocate space in this task group's TWSC pool. The frequency with which this field is updated is based on the value of the Parameter table field `wksp_coll_interval` (see Table 9.8).

- `twsc_pool_garbage`

The number of garbage collections that have been run to reclaim space in this task group's TWSC pool. The frequency with which this field is updated is based on the value of the Parameter table field `wksp_coll_interval` (see Table 9.8).

## 9.13. Trap Table

The Trap table is used to control which events trigger the Remote Manager to generate an SNMP trap. The ACMS Remote Manager populates this table from the configuration file at system startup. Thereafter, users make modifications to this table through either the SNMP interface or the ACMSMGR interface.

The primary key to this table is the combination of entity, name, and parameter. Duplicate rows are not allowed.

**Table 9.12. Trap Table**

Field	Data Type	SNMP Access	RPC Access	Configuration Access	Dynamic
entity	integer	R	RW	RW	D
name	string	R	RW	RW	D
parameter	integer	R	RW	RW	D
min_value	integer	RW	RW	RW	D
max_value	integer	RW	RW	RW	D
severity	integer	RW	RW	RW	D
alarms_sent	integer	R	R		
alarm_last_sent	integer	R	R		
trap_delete	integer	RW			D
<b>Key to Access Modes</b> <b>R – Read Access</b> <b>RW – Read/Write Access</b> <b>Blank – Not available to the interface</b> <b>D – Field is dynamic</b>					

## 9.13.1. Field Descriptions

Following are descriptions of the fields in Table 9.12.

- entity

Name or type of the entity. Valid values are ACC, CP, EXC, MGR, QTI, and TSC. Symbolic values for the RPC interface are defined in Section 8.1.4. This value for entity cannot be changed from the SNMP interface.

- name

A name for the entity that helps to uniquely identify an instance of the entity type. This value cannot be changed from the SNMP interface. Possible entity names are:

- ACC, CP, QTI, TSC (process name)
- EXC (application name)
- GROUP (task group name)
- MGR: Must be \*
- SERVER (server name): One of the following wildcard values:
  - asterisk (\*) (matches all characters)
  - exclamation point (!) (negation)

- parameter

Parameter specifies the value or condition to be monitored for potential alarms. This value cannot be changed from the SNMP interface.

Not all parameters are valid for all entity types (see Table 9.13). Valid values are:

- EVENT\_SEVERITY

This parameter causes a test to be performed each time an auditable event is raised in the Remote Manager. Remote Manager events are filtered using the fields in the Parameter table (see Section 9.9) and are stored in the Remote Manager log (see Section 4.7). Events are monitored for traps even if the event is not currently being logged.

- EXISTS

This parameter causes a test to be performed each time the Remote Manager detects that a process has started or stopped.

- min\_value

The minimum allowable value for the parameter. Valid minimums are parameter dependent (see Table 9.13). If the field or condition being monitored is less than the value specified, an alarm is generated. A value of -1 is used when this field is not to be evaluated.

- max\_value

The maximum allowable value for the parameter. Valid maximums are parameter dependent (see Table 9.13). If the field or condition being monitored is greater than the value specified, an alarm is generated. A value of -1 is used when this field is not to be evaluated.

- severity

A severity to be associated with the trap. Severity codes are embedded in the trap message (see Section 9.14.3) and must be parsed by the trap receiver. Valid values are:

- INFO
- WARN
- ERROR
- FATAL

- alarms\_sent

A count of the number of alarms that have been sent.

- alarm\_last\_sent

The date and time the last alarm was sent.

- trap\_delete

This field is available only through the SNMP interface. Set this field to 1 to delete the table row. RPC users call the procedure shown in ACMSMGMT\_DELETE\_TRAP\_1. ACMSMGR and ACMSCFG each provide a DELETE TRAP command for this purpose.

## 9.14. Valid Trap Minimums and Maximums

Table 9.13 lists the values that can be specified as the minimum or maximum for each parameter type.

**Table 9.13. Trap Minimums and Maximums**

Parameter	Value	Meaning	Valid for These Entities
EVENT_SEVERITY	1	Informational	MGR
	1	Warning	MGR
	1	Error	MGR
	1	Fatal	MGR
	2	Ignore this field.	MGR
EXISTS	3	Stopped	ACC, CP, EXC, QTI, TSC
	4	Started	ACC, CP, EXC, QTI, TSC
	2	Ignore this field.	ACC, CP, EXC, QTI, TSC

<sup>1</sup>When configuring alarms for event severities, remember how the values are evaluated. For example, specifying the value 8 (FATAL) as a minimum results in an alarm being generated by all lesser severities. Similarly, specifying the value 1 (INFO) as a maximum results in an alarm being generated by all greater severities.

<sup>2</sup>The value of -1 causes the field to be ignored. When configuring traps, it is not always desirable to specify both minimum and maximum values. The value -1 can be used as a null placeholder when either value is to be ignored.

<sup>3</sup>When specified as a maximum, this value causes an alarm to be generated whenever the associated entity type and name is started. This value can be used, for example, to signal when the QTI has been started on a node on which it should not run.

<sup>4</sup>When specified as a minimum, this value causes an alarm to be generated whenever the associated entity type and name is stopped. This value can be used, for example, to signal when a particular application has been stopped.

### 9.14.1. Field Descriptions

Following are descriptions of the fields in the table above:

- entity

Name or type of the entity. Valid values are ACC, CP, EXC, MGR, QTI, and TSC. Symbolic values for the RPC interface are defined in Section 8.1.4. This value for entity cannot be changed from the SNMP interface.

- name

A name for the entity that helps to uniquely identify an instance of the entity type. This value cannot be changed from the SNMP interface. Possible entity names are:

- ACC, CP, QTI, TSC (process name)
- EXC (application name)
- GROUP (task group name)
- MGR: Must be \*
- SERVER (server name): One of the following wildcard values:

- asterisk (\*) (matches all characters)
- exclamation point (!) (negation)
- parameter

Parameter specifies the value or condition to be monitored for potential alarms. This value cannot be changed from the SNMP interface.

Not all parameters are valid for all entity types. Valid values are:

- EVENT\_SEVERITY

This parameter causes a test to be performed each time an auditable event is raised in the Remote Manager. Remote Manager events are filtered using the fields in the Parameter table and are stored in the Remote Manager log. Events are monitored for traps even if the event is not currently being logged.

- EXISTS

This parameter causes a test to be performed each time the Remote Manager detects that a process has started or stopped.

- min\_value

The minimum allowable value for the parameter. Valid minimums are parameter dependent. If the field or condition being monitored is less than the value specified, an alarm is generated. A value of -1 is used when this field is not to be evaluated.

- max\_value

The maximum allowable value for the parameter. Valid maximums are parameter dependent. If the field or condition being monitored is greater than the value specified, an alarm is generated. A value of -1 is used when this field is not to be evaluated.

- severity

A severity to be associated with the trap. Severity codes are embedded in the trap message and must be parsed by the trap receiver. Valid values are:

- INFO
- WARN
- ERROR
- FATAL

- alarms\_sent

A count of the number of alarms that have been sent.

- alarm\_last\_sent

The date and time the last alarm was sent.

- trap\_delete

This field is available only through the SNMP interface. Set this field to 1 to delete the table row. RPC users call the procedure shown in ACMSMGMT\_DELETE\_TRAP\_1. ACMSMGR and ACMSCFG each provide a DELETE TRAP command for this purpose.

## 9.14.2. Valid Trap Minimums and Maximums

The table below lists the values that can be specified as the minimum or maximum for each parameter type.

Parameter	Value	Meaning	Valid for These Entities	Comments
EVENT_SEVERITY		Informational	MGR	When configuring alarms for event severities, remember how the values are evaluated. For example, specifying the value 8 (FATAL) as a minimum results in an alarm being generated by all lesser severities. Similarly, specifying the value 1 (INFO) as a maximum results in an alarm being generated by all greater severities.
	2	Warning	MGR	When configuring alarms for event severities, remember how the values are evaluated. For example, specifying the value 8 (FATAL) as a minimum results in an alarm being generated by all lesser severities. Similarly, specifying the value 1 (INFO) as a maximum results in an alarm being generated by all greater severities.



	4	Error	MGR	<p>When configuring alarms for event severities, remember how the values are evaluated. For example, specifying the value 8 (FATAL) as a minimum results in an alarm being generated by all lesser severities. Similarly, specifying the value 1 (INFO) as a maximum results in an alarm being generated by all greater severities.</p>
	8	Fatal	MGR	<p>When configuring alarms for event severities, remember how the values are evaluated. For example, specifying the value 8 (FATAL) as a minimum results in an alarm being generated by all lesser severities. Similarly, specifying the value 1 (INFO) as a maximum results in an alarm being generated by all greater severities.</p>
	-1	Ignore this field.	MGR	<p>The value of -1 causes the field to be ignored. When configuring traps, it is not always desirable to specify both minimum and maximum values. The value -1 can be used as a null placeholder when</p>

				either value is to be ignored.
EXISTS	0	Stopped	ACC, CP, EXC, QTI, TSC	When specified as a maximum, this value causes an alarm to be generated whenever the associated entity type and name is started. This value can be used, for example, to signal when the QTI has been started on a node on which it should not run.
	1	Started	ACC, CP, EXC, QTI, TSC	When specified as a minimum, this value causes an alarm to be generated whenever the associated entity type and name is stopped. This value can be used, for example, to signal when a particular application has been stopped.
	-1	Ignore this field.	ACC, CP, EXC, QTI, TSC	The value of -1 causes the field to be ignored. When configuring traps, it is not always desirable to specify both minimum and maximum values. The value -1 can be used as a null placeholder when either value is to be ignored.

### 9.14.3. SNMP Trap Format

The following is the format of an SNMP trap message. Note that the message is generated as an ASCII string. Fields within the string are separated by a colon.

```
time: severity: entity_type: entity_name: parameter: value
```

In this format:

- *time* is a 23-character ASCII time in the format *DD-MMM-YYYY HH:MM:SS.hh*.
- *severity* is a single ASCII character that specifies the severity as determined from the severity field in the table that raised the alarm. Severities are:
  - I (informational)
  - W (warning)
  - E (error)
  - F (fatal)
- *entity\_type* is one of the valid entity types (ACC, TSC, QTI, EXC, CP, MGR) and represents the entity that caused the alarm to be raised.
- *entity\_name* is the process name of the entity that raised the alarm.
- *parameter* is the parameter that caused the alarm to be raised.
- *value* is the value that caused the alarm to be raised.

## 9.15. TSC Table

The TSC table contains a single entry for TSC management information.

**Table 9.14. TSC Table**

Collection Class	Field	Data Type	SNMP Access	RPC Access	Dynamic
ID	record_state	integer	R	R	
ID	id_coll_state	integer	R	R	
ID	process_name	string	R	R	
ID	pid	integer	R	R	
ID	start_time	time	R	R	
ID	end_time	time	R	R	
CONFIG	config_coll_state	integer	R	R	
CONFIG	tsc_priority_active	integer	R	R	
CONFIG	acms_state	integer	RW	R	D
CONFIG	tsc_priority_store	integer	RW	RW	
CONFIG	tsc_username_active	string	R	R	
CONFIG	tsc_username_store	string	RW	RW	
CONFIG	cp_priority_active	integer	R	R	
<b>Key to Access Modes</b>					
<b>R – Read Access</b>					
<b>RW – Read/Write Access</b>					
<b>Blank – Not available to the interface</b>					
<b>D – Field is dynamic</b>					

Collection Class	Field	Data Type	SNMP Access	RPC Access	Dynamic
CONFIG	cp_priority_stored	integer	RW	RW	
CONFIG	cp_slots_active	integer	R	R	
CONFIG	cp_slots_stored	integer	RW	RW	
CONFIG	max_logins_active	integer	RW	RW	D
CONFIG	max_logins_stored	integer	RW	RW	
CONFIG	max_tts_cp_active	integer	RW	RW	D
CONFIG	max_tts_cp_stored	integer	RW	RW	
CONFIG	perm_cps_active	integer	RW	RW	D
CONFIG	perm_cps_stored	integer	RW	RW	
CONFIG	min_cpis_active	integer	RW	RW	D
CONFIG	min_cpis_stored	integer	RW	RW	
CONFIG	cp_username_active	integer	R	R	
CONFIG	cp_username_stored	integer	RW	RW	
RUNTIME	runtime_coll_state	integer	R	R	
RUNTIME	current_users	gauge	R	R	
POOL	pool_coll_state	integer	R	R	
POOL	mss_process_total	integer	R	R	
POOL	mss_process_free	min gauge	R	R	
POOL	mss_process_large	min gauge	R	R	
POOL	mss_process_failed	integer	R	R	
POOL	mss_process_garbage	integer	R	R	
<b>Key to Access Modes</b> <b>R – Read Access</b> <b>RW – Read/Write Access</b> <b>Blank – Not available to the interface</b> <b>D – Field is dynamic</b>					

## 9.15.1. Field Descriptions

Following are descriptions of the fields in Table 9.14.

- record\_state

The current state of this table entry. Valid states are VALID (the process is currently running and maintaining this table entry) or INACTIVE (the process is no longer running). Inactive rows are subject to reuse.

- id\_coll\_state

The current collection state for this class and this process. Collection states can be modified by modifying entries in the Collection table. See Section 5.1 and Section 9.4 for discussions of data collection.

- `process_name`  
The OpenVMS process name for the process.
- `pid`  
The OpenVMS process identifier for the process.
- `start_time`  
Date and time the process was started.
- `end_time`  
Date and time the process ended. If the process has not yet ended, this field will be null.
- `config_coll_state`  
The current collection state for this class and this process. Collection states can be modified by modifying entries in the Collection table. See Section 5.1 and Section 9.4 for discussions of data collection.
- `tsc_priority_active`  
The base priority for this process. This is the value of the ACMSGEN field when the process was started.
- `tsc_priority_stored`  
The base priority currently stored in the ACMSGEN file for this process.
- `tsc_username_active`  
The OpenVMS account under which the TSC will run. The `tsc_username_active` is the value of the ACMSGEN field when the process was started.
- `tsc_username_stored`  
The value of the `tsc_username` field currently stored in the ACMSGEN file.
- `cp_priority_active`  
The base priority for CP processes. This is the value of the ACMSGEN field when the TSC process was started.
- `cp_priority_stored`  
The base priority currently stored in the ACMSGEN file for CP processes.
- `cp_slots_active`  
The current number of CP slots. This is the value of the ACMSGEN field when the TSC process was started. This field also represents the maximum number of entries in the CP table.
- `cp_slots_stored`

The value of the `cp_slots` field in the current ACMSGEN file.

- `max_logins_active`

The current maximum number of logins allowed.

- `max_logins_stored`

The value of the `max_logins` field in the current ACMSGEN file.

- `max_tts_cp_active`

The current maximum number of terminals that a CP will support.

- `max_tts_cp_stored`

The value of the `max_tts_cp` field in the current ACMSGEN file.

- `perm_cps_active`

The number of permanent CPs that will be maintained on the system.

- `perm_cps_stored`

The value of the `perm_cps` field in the current ACMSGEN file.

- `min_cpis_active`

The number of CP slots that will be left open on a given CP.

- `min_cpis_stored`

The value of the `min_cpis` field in the current ACMSGEN file.

- `cp_username_active`

The current user name under which CP processes will run.

- `cp_username_stored`

The value of the `cp_username` field in the current ACMSGEN file.

- `acms_state`

Current ACMS state of the process.

- `runtime_coll_state`

The current collection state for this class and this process. Collection states can be modified by modifying entries in the Collection table. See Section 5.1 and Section 9.4 for discussions of data collection.

If this field is set to `DISABLED`, the process is not currently collecting data for the fields in this class. Any field values reflect activity during a prior period when collection was enabled.

- `current_users`

The current number of terminal users in all CPs started by this TSC.

- `pool_coll_state`

The current collection state for this class and this process. Collection states can be modified by modifying entries in the Collection table. See Section 5.1 and Section 9.4 for discussions of data collection.

If this field is set to `DISABLED`, the process is not currently collecting data for the fields in this class. Any field values reflect activity during a prior period when collection was enabled.

- `mss_process_total`

The total size of the MSS process pool allocated for this process. The frequency with which this field is updated is based on the value of the Parameter table field `mss_coll_interval` (see Table 9.8).

- `mss_process_free`

The amount of unused MSS process pool for this process. The frequency with which this field is updated is based on the value of the Parameter table field `mss_coll_interval` (see Table 9.8).

- `mss_process_largest`

The largest unused block available in the MSS process pool for this process. The frequency with which this field is updated is based on the value of the Parameter table field `mss_coll_interval` (see Table 9.8).

- `mss_process_failures`

The number of failed attempts to allocate space in the MSS process pool for this process. The frequency with which this field is updated is based on the value of the Parameter table field `mss_coll_interval` (see Table 9.8).

- `mss_process_garbage`

The number of garbage collections that have been run to reclaim space in the MSS process pool for this process. The frequency with which this field is updated is based on the value of the Parameter table field `mss_coll_interval` (see Table 9.8).

## 9.16. Users Table

The Users table contains information about users who have logged in to Remote Manager, either explicitly (using a user name and password) or implicitly (using a proxy account). This table is maintained internally by the Remote Manager and is read only to all external entities. Values in the table can be accessed through one of the supported interfaces. External users cannot make changes to this table.

In general, the values in this table are informational only.

**Table 9.15. Users Table**

Field Name	Data Type	SNMP Access	RPC Access	Dynamic
client_id	integer	R	R	
gid	short integer	R	R	
uid	short integer	R	R	
proxy_gid	short integer	R	R	
proxy_uid	short integer	R	R	
nodename	string	R	R	
expires	string	R	R	
uname	string	R	R	
rights	integer array	R	R	
proxy_flag	integer	R	R	
<b>Key to Access Modes</b>				
<b>R – Read Access</b>				
<b>RW – Read/Write Access</b>				
<b>Blank – Not available to the interface</b>				
<b>D – Field is dynamic.</b>				

### 9.16.1. Field Descriptions

Following are descriptions of the fields in Table 9.15.

- client\_id  
Unique number that identifies this client.
- gid  
Group portion of the user's UIC on the client node.
- uid  
User portion of the user's UIC on the client node,
- proxy\_gid  
Group portion of the UIC from the proxy account on the server node.
- proxy\_uid  
User portion of the UIC from the proxy account on the server node.
- nodename  
Name of client node. This is the only node from which the client ID is valid.
- expires  
Date and time the user log in expires. Full OpenVMS ASCII date (*DD-MMM-YYYY  
HH:MM:SS.hh*).



- `uname`

Account name of the account being used for authorization. This can be the account name for the proxy.

- `rights`

Rights held by the user. This is an array of three elements. The first element contains the ACMS\$MGMT\_READ rights identifier; the second contains the ACMS\$MGMT\_WRITE rights identifier; the third contains the ACMS\$MGMT\_OPER identifier. A value of 0 indicates the user does not hold the right.

- `proxy_flag`

A flag indicating whether the user has explicitly logged in (value of 0) or implicitly logged in by means of proxy (value of 1).



# Chapter 10. ACMSCFG Commands

This chapter provides reference information about the commands of the ACMSCFG utility.

## 10.1. ACMSCFG Overview

The ACMSCFG utility is provided for performing operations on the ACMS Remote Manager configuration file. Similar to the ACMSMGR utility (described in Chapter 11), the ACMSCFG utility performs only a subset of the operations that the ACMSMGR utility performs.

The ACMSCFG utility performs operations on the Remote Manager configuration file only, and only on configuration files that are directly accessible to the process running the utility.

Section 4.2 discusses the purpose and use of the configuration file, as well as file defaults.

### 10.1.1. Command Format

The format for ACMSCFG commands is as follows:

```
ACMSCFG verb object qualifiers
```

The following verbs are supported:

- ADD
- DELETE
- HELP
- SET
- SHOW

Each verb has associated objects. The following sections list the objects and any qualifiers for each ACMSCFG command.

### 10.1.2. Command Objects and Qualifiers

The objects and qualifiers for the ACMSCFG commands are summarized in Table 10.1.

**Table 10.1. ACMSCFG Command Objects and Qualifiers**

Objects	Qualifiers
ADD Command	
COLLECTION	/CLASS, /COLL_STATE, /ENTITY, /NAME, /STORAGE_END_TIME, /STORAGE_INTERVAL, /STORAGE_LOCATION, /STORAGE_BEGIN_TIME, /STORAGE_STATE
TRAP	/ENTITY, /NAME, /PARAMETER, /SEVERITY, /TRAP_MIN, /TRAP_MAX
DELETE Command	
COLLECTION	/CLASS, /ENTITY, /NAME

Objects	Qualifiers
TRAP	/ENTITY, /NAME, /PARAMETER
HELP Command	
None.	None.
SET Command	
COLLECTION	/CLASS, /COLL_STATE, /ENTITY, / NAME, /STORAGE_END_TIME, / STORAGE_INTERVAL, / STORAGE_LOCATION, /STORAGE_ BEGIN_TIME, /STORAGE_STATE
INTERFACE	/INTERFACE, /STATE
PARAMETER	/DCL_AUDIT_LEVEL, / DCL_MGR_PRIORITY, / DCL_STACKSIZE, /ERROR_INTERVAL, / EVENT_LOG_PRIORITY, / LOG_STACKSIZE, / LOGIN_CREDS_LIFETIME, / MAX_LOGINS, /MAX_RPC_RETURN_ RECS, /MGR_AUDIT_LEVEL, / MSG_PROC_AUDIT_LEVEL, / MSG_PROC_PRIORITY, / MSG_PROC_STACKSIZE, / MSS_COLL_INTERVAL, / PROC_MON_AUDIT_LEVEL, /PROC_MON_ INTERVAL, /PROC_MON_PRIORITY, / PROC_MON_STACKSIZE, / PROXY_CREDS_LIFETIME, / RPC_AUDIT_LEVEL, /RPC_ PRIORITY, /RPC_STACKSIZE, / SECURITY_AUDIT_LEVEL, / SNAP_AUDIT_LEVEL, / SNAP_PRIORITY, /SNAP_STACKSIZE, / SNMP_AGENT_TIME_OUT, / SNMP_ARE_YOU_THERE, /SNMP_AUDIT_ LEVEL, /SNMP_PRIORITY, / SNMP_SEL_TIME_OUT, /SNMP_ STACKSIZE, /TCP_ENABLED, / TIMER_AUDIT_LEVEL, /TIMER_ INTERVAL, /TIMER_PRIORITY, / TIMER_STACKSIZE, / TOTAL_ENTITY_SLOTS, / TRACE_MSG_WAIT_TIME, /TRACE_START_ WAIT_TIME, /TRAP_AUDIT_LEVEL, / TRAP_PRIORITY, /TRAP_STACKSIZE, / UDP_ENABLED, /VMS_COLL_INTERVAL, / WKSP_COLL_INTERVAL, /MAX_AGENTS
TRAP	/ENTITY, /NAME, /PARAMETER, / SEVERITY, /TRAP_MIN, /TRAP_MAX
SHOW Command	

Objects	Qualifiers
COLLECTION	/BRIEF, /FULL
CONTROL	None
INTERFACE	None
PARAMETER	None
TRAP	None

## 10.2. ACMSCFG ADD COLLECTION

### ACMSCFG ADD COLLECTION

ACMSCFG ADD COLLECTION — Adds records to the collection table in the configuration file.

#### Format

ACMSCFG ADD COLLECTION [/qualifiers]

Command Qualifier	Default
/CLASS=keyword	* (all)
/COLL_STATE=keyword	DISABLED
/ENTITY=keyword	None
/NAME=[*,proc_name]	* (all)
/STORAGE_END_TIME=[NEVER, /time]	NEVER; run until DISABLED  Only for use on systems running ACMS Version 4.4 or higher.
/STORAGE_INTERVAL=value	300  Only for use on systems running ACMS Version 4.4 or higher.
/STORAGE_LOCATION=file-name	Translation of logical ACMS \$MGMT_SNAPSHOT.  Only for use on systems running ACMS Version 4.4 or higher.
/STORAGE_BEGIN_TIME=[NOW, /time]	NOW; start as soon as ENABLED.  Only for use on systems running ACMS Version 4.4 or higher.
/STORAGE_STATE=keyword	DISABLED.  Only for use on systems running ACMS Version 4.4 or higher.

#### Privileges Required

None.

## Parameters

None.

## Qualifiers

`/CLASS=[*, ERROR, POOL, RUNTIME]`

This qualifier determines the class that will be enabled or disabled. The default is all (\*). See Section 5.1.1 for a description of each class type.

`/COLL_STATE=[ENABLED, DISABLED]`

This qualifier specifies the state of the collection. The default is `DISABLED`. When a `SHOW` entity command is issued, data for those classes that have their collection state set to `ENABLED` is displayed. Note that while the collection state is `DISABLED`, the data displayed for an entity may not be accurate. Data cannot be written to the data snapshot file when this qualifier is `DISABLED`, even when the storage state is `ENABLED`.

`/ENTITY=[*, ACC, CP, EXC, GROUP, QTI, SERVER, TSC]`

This required qualifier specifies the entity for which collection should be enabled or disabled.

`/NAME=[*, entity-name]`

This qualifier specifies particular instances of an entity. Wildcards (\*) are allowed in names.

For `ACC`, `CP`, `QTI`, and `TSC` entity types, the entity name is the process name. For the `EXC` entity type, the entity name is the name of the application (for example, `VR_APPL`).

Server and task group names can be specified as compound names made up of an application name and a server or task group name, separated by a period (for example, `VR_APPL.VR_READ_SERVER`). Either part of server or task group names can be a wildcard (for example, `*.VR_READ_SERVER` or `VR_APPL.*`). If only one part of a server or task group name is specified, it is assumed to be the application name, and the server or task group name is wildcarded. For example, `VR_APPL` is equivalent to `VR_APPL.*`.

The default is all (\*), which is equivalent to `*.*` for a compound name.

`/STORAGE_END_TIME=[NEVER, time]`

This qualifier specifies a time after which the collection data should no longer be written to the snapshot file. The format of *time* is `DD-MMM-YY:hh:mm:ss.nn`. Partial dates and times (for example, `10-OCT` or `09:00`) are supported. If this qualifier is not specified, the default keyword of `NEVER` is applied, which equates to the OpenVMS zero date of `17-NOV-1858 00:00:00.00`. With a value of `NEVER`, collection data continues to be written to the snapshot file until the storage state is set to `DISABLED`.

`/STORAGE_INTERVAL=value`

This qualifier controls the frequency (in seconds) at which data snapshots are performed. The default value is 300 seconds.

The storage interval value should be a multiple of the timer interval parameter (`SET PARAMETER/TIMER_INTERVAL`). The timer interval value determines the minimum elapsed time for many Remote Manager parameters, including the storage interval setting. The relationship of these values determine how often data snapshots are performed, for example:

- If the timer interval value is greater, its value is used by default. For instance, if the timer interval is 10 and the storage interval is 5, snapshots will be written at 10 second intervals.
- If the storage interval value is greater and is a multiple of the timer interval, the storage interval value is used. For example, if the timer interval is 10 and the storage interval is 30, snapshots will be written at 30 second intervals.
- If the storage interval value is greater and is not a multiple of the timer interval, the next multiple of the timer interval value is used. For example, if the timer interval is 10 and the storage interval is 15, snapshots will be written at 20 second intervals.

`/STORAGE_LOCATION=file-name`

This qualifier specifies an OpenVMS file specification to which collection data is to be written. The format of *file-name* is a valid OpenVMS pathname or logical (such as DISK\$1:[SYSTEM.SNAPSHOTS] or SYS\$SYSTEM:SNAPSHOTS.DAT).

If the `/STORAGE_LOCATION` qualifier is not specified, the ACMSMGR utility checks for the presence of the logical name ACMS\$MGMT\_SNAPSHOT. If the logical is defined, the value of the logical is used by default. If a directory is not provided as part of the specification, the file is written to the default directory of the account under which the Remote Manager process is running.

Multiple collections can share a single snapshot file or be stored in separate files. For continuity, Compaq recommends that EXC, Server, and Task Group collection information be written to the same snapshot file.

`/STORAGE_START_TIME=[NOW, time]`

This qualifier specifies a time after which the collection data should be written to the snapshot file. The format of *time* is *DD-MMM-YY:hh:mm:ss.nn*. Partial dates and times (for example, 10-OCT or 09:00) are supported. If this qualifier is not specified, the default keyword of NOW is applied, which equates to the OpenVMS zero date of 17-NOV-1858 00:00:00.00. With a value of NOW, collection data is written to the snapshot file immediately, or as soon as the storage state is set to ENABLED.

`/STORAGE_STATE=[ENABLED, DISABLED]`

This qualifier specifies the state of the data snapshots. If this qualifier is not specified, data snapshots are disabled by default. To fully enable data snapshots, both the storage state and the collection state (`/COLL_STATE`) must be set to ENABLED.

## Notes

When adding new collection records, the combination of class, entity, and name must be unique.

It is not possible to add records for the ID and CONFIG class. By default, all ACMS processes collect ID and CONFIG class data.

ACMS processes read the Collection table during process startup to determine which classes to begin collecting. Once the Remote Manager has been started, the ACMSMGR SHOW PROCESS command can be used to determine the class states for the currently running ACMS processes.

In order for collection data to be written to a snapshot file, the following conditions must be met:

- A qualifying entity must be running (one with an entity type and name matching fields in the Collection table).
- The collection state and storage state for that entity must be enabled.
- The current time must fall between the storage start time and storage end time.

If all these conditions are met, the Remote Manager opens the snapshot file for shared write operations. The file remains open until the storage state is set to `DISABLED` or until the snapshot period expires.

When multiple collection records apply to a given process, the records are assigned weights according to a precedence of name, then entity, and then class. Within a column, wildcard entries are weighted less than nonwildcard entries. The row with the highest weight that applies to a process is used. The command `ACMSMGR SHOW COLLECTIONS` displays weights for each row in the table. See Section 5.1.1 for a discussion of the Collection table and how weights are assigned.

In contrast to typical collections, weighting for data snapshot threads does not apply. Therefore, it is possible for redundant collection data to be written to one or more snapshot files. If multiple collection records compile overlapping data, and each has their storage state set to `ENABLED`, each record writes data to the designated snapshot file.

See Section 11.2 for a discussion about adding collection records at run time.

## Examples

```
$ ACMSCFG ADD COLLECTION/ENTITY=EXC/CLASS=RUNTIME/NAME=VR_APPL
```

This command creates an entry in the Collection table in the configuration file.

## 10.3. ACMSCFG ADD TRAP

### ACMSCFG ADD TRAP

`ACMSCFG ADD TRAP` — Adds records to the trap table in the configuration file.

#### Format

`ACMSCFG ADD TRAP [/qualifiers]`

Command Qualifier	Default
<code>/ENTITY=keyword</code>	None
<code>/NAME=[*,entity-name]</code>	* (all )
<code>/PARAMETER=keyword</code>	EXISTS
<code>/SEVERITY=[I,W,E,F]</code>	E
<code>/TRAP_MIN=value</code>	-1
<code>/TRAP_MAX=value</code>	-1

#### Privileges Required

None.



## Parameters

None.

## Qualifiers

`/ENTITY=[*, ACC, CP, EXC, MGR, QTI, TSC]`

This required qualifier determines the entities for which a trap should be set.

`/NAME=[*,entity-name]`

This qualifier specifies particular instances of an entity. In general, the entity name is the process name. The exceptions are the EXC entity and the MGR entity.

For the EXC entity, use the assigned application name.

For the MGR entity, you must specify all (\*).

Wildcards (\*) are allowed in names. The default qualifier is the asterisk (\*) wildcard.

`/PARAMETER=[EVENT_SEVERITY, EXISTS]`

The field that should be monitored. Valid values are:

- EVENT\_SEVERITY

This parameter is used for monitoring internal Remote Manager events. The Remote Manager logs internal events in the Remote Manager log. (See Section 4.7 and Section 11.35 for discussions of the Remote Manager log.) Traps can be generated based on the severity levels of these events.

- EXISTS

This parameter is used for monitoring process existence. Traps are generated if the associated entity type and name either start or stop.

`/SEVERITY=[I, W, E, F]`

A severity to be associated with the trap. Severity codes are embedded in the trap message and must be parsed by the trap receiver. Severities can be informational (I), warning (W), error (E), and fatal (F).

`/TRAP_MIN=value`

This qualifier specifies the minimum allowable value for the parameter being monitored. A trap is generated if the parameter value is less than the minimum value. See Table 9.12 for a list of valid /TRAP\_MIN values.

`/TRAP_MAX=value`

This qualifier specifies the maximum allowable value for the parameter being monitored. A trap is generated if the parameter value is greater than the maximum value. See Table 9.12 for a list of valid /TRAP\_MAX values.

## Notes

When adding new trap records, the combination of entity, name, and parameter must be unique.

See Section 9.14.2 for a discussion about setting appropriate trap minimums and maximums. See Section 9.14.3 for a description of the trap message generated.

## Examples

```
$ ACMSCFG ADD TRAP /ENTITY=ACC/PARAMETER=EXISTS/TRAP_MIN=1
```

This command causes an SNMP trap to be generated whenever the ACC process stops if the SNMP interface is running.

# 10.4. ACMSCFG DELETE COLLECTION

## ACMSCFG DELETE COLLECTION

ACMSCFG DELETE COLLECTION — Deletes records from the collection table in the configuration file.

### Format

ACMSCFG DELETE COLLECTION [/qualifiers]

Command Qualifier	Default
/CLASS=keyword	* (all)
/ENTITY=keyword	None
/NAME=[*,entity-name]	* (all)

### Privileges Required

None.

### Parameters

None.

### Qualifiers

/CLASS=[\*, CONFIG, ERROR, ID, POOL, RUNTIME]

This qualifier determines the class that will be enabled or disabled. See Section 5.1.1: Entities, Classes, Names, and Collections for a description of each class type.

/ENTITY=[\*, ACC, AGENT, CP, EXC, GROUP, QTI, SERVER, TSC]

This required qualifier determines the entities for which collection should be enabled or disabled.

/NAME=[\*,entity-name]

This qualifier specifies particular instances of an entity. Wildcards (\*) are allowed in names.

For ACC, AGENT, CP, QTI, and TSC entity types, the entity name is the process name. For EXCs, the entity name is the name of the application (for example, VR\_APPL).

Server and task group names can be specified as compound names made up of application name and server or task group name, separated by a period (for example, VR\_APPL.VR\_READ\_SERVER). Either part of server or task group names can be a wildcard (for example, \*.VR\_READ\_SERVER or VR\_APPL.\*). If only one part of a server or task group name is specified, it is assumed to be the application name, and a wildcard is used as the server or task group name. For example, VR\_APPL is equivalent to VR\_APPL.\*.

The default is all (\*), which is equivalent to \*.\* for a compound name.

## Notes

When deleting collection records, the combination of class, entity, and name must exactly match the row to be deleted.

It is not possible to delete records for the ID and CONFIG class. By default, all ACMS processes collect ID and CONFIG class data.

When multiple collection records apply to a given process, the records are assigned weights according to a precedence of name, then entity, then class. Within a column, wildcard entries are weighted less than nonwildcard entries. The row with the highest weight that applies to a process is used. The ACMSMGR SHOW COLLECTIONS command displays weights for each row in the table. See also Section 5.1.1 for a discussion of the Collection table and how weights are assigned.

See Section 5.1.1 for a discussion about deleting collection records at run time.

## Examples

```
$ ACMSCFG DELETE COLLECTION/ENTITY=EXC/CLASS=RUNTIME/NAME=VR_APPL
```

This command deletes the entry in the Collection table for run-time collection by the VR\_APPL application.

# 10.5. ACMSCFG DELETE TRAP

## ACMSCFG DELETE TRAP

ACMSCFG DELETE TRAP — Deletes a record from the trap table in the configuration file.

### Format

ACMSCFG DELETE TRAP [/qualifiers]

Command Qualifier	Default
/ENTITY=keyword	None
/NAME=[*,entity-name]	* (all)
/PARAMETER=keyword	EXISTS

### Privileges Required

None.

## Parameters

None.

## Qualifiers

/ENTITY=[\*, ACC, CP, EXC, MGR, QTI, TSC]

This required qualifier determines the entity or entities for which a trap should be set.

/NAME=[\*,entity-name]

This qualifier specifies particular instances of an entity. In general, the entity name is the process name. The exceptions are the EXC entity and the MGR entity.

For the EXC entity, use the assigned application names.

For the MGR entity, you must specify all (\*).

Wildcards (\*) are allowed in names. The default qualifier is the asterisk (\*) wildcard.

/PARAMETER=[EVENT\_SEVERITY,EXISTS]

The field that should be monitored. Valid values are:

- EVENT\_SEVERITY

This parameter is used for monitoring internal Remote Manager events. The Remote Manager logs internal events in the Remote Manager log. (See Section 4.7 and Section 11.35 for discussions of the Remote Manager log.) Traps can be generated based on the severity levels of these events.

- EXISTS

This parameter is used for monitoring process existence. Traps are generated if the associated entity type and name either start or stop.

## Notes

When deleting trap records, the combination of entity, name, and parameter must exactly match a row in the Trap table.

## Examples

```
$ ACMSCFG DELETE TRAP/ENTITY=ACC/PARAMETER=EXISTS
```

This command deletes a trap from the Trap table in the configuration file.

## ACMSCFG HELP

ACMSCFG HELP — Displays help information about the ACMS Configuration utility (ACMSCFG) and its commands.

## Format

ACMSCFG HELP

## Privileges Required

None.

## Parameters

None.

## Qualifiers

None.

## Notes

Online help is available for each ACMSCFG command. Each help topic summarizes the valid syntax, abbreviations, parameters, and qualifiers for a particular command and also indicates all default and required values.

For a comprehensive list of ACMS utilities that offer online help or for further instructions on how to invoke help, see ACMS Help.

## Examples

```
$ ACMSCFG HELP
```

This command invokes online help for the ACMSCFG utility and displays a list of available topics.

# 10.6. ACMSCFG SET COLLECTION

## ACMSCFG SET COLLECTION

ACMSCFG SET COLLECTION — Adds records to the collection table in the configuration file.

### Format

**ACMSCFG SET COLLECTION [/qualifiers]**

Command Qualifier	Default
/CLASS=keyword	* (all )
/COLL_STATE=keyword	None
/ENTITY=keyword	None
/NAME=[*,entity-name]	* (all )
/STORAGE_END_TIME=[NEVER, /time]	None Only for use on systems running ACMS Version 4.4 or higher.
/STORAGE_INTERVAL=value	None Only for use on systems running ACMS Version 4.4 or higher.

Command Qualifier	Default
/STORAGE_LOCATION=file-name	Translation of logical ACMS \$MGMT_SNAPSHOT  Only for use on systems running ACMS Version 4.4 or higher.
/STORAGE_BEGIN_TIME=[NOW, /time]	None  Only for use on systems running ACMS Version 4.4 or higher.
/STORAGE_STATE=keyword	Only for use on systems running ACMS Version 4.4 or higher.

## Privileges Required

None.

## Parameters

None.

## Qualifiers

/CLASS=[\*, CONFIG, ERROR, ID, POOL, RUNTIME]

This qualifier determines the class that will be enabled or disabled. See Section 5.1.1: Entities, Classes, Names, and Collections for a description of each class type.

/COLL\_STATE=[ENABLED, DISABLED]

This qualifier specifies the state of the collection. When an ACMSMGR SHOW entity command is issued, data for those classes that have their collection state set to ENABLED is displayed. Note that while the collection state is DISABLED, data is not collected. As a result, data cannot be written to the data snapshot file when this qualifier is DISABLED, even when the storage state is ENABLED.

/ENTITY=[\*, ACC, AGENT, CP, EXC, GROUP, QTI, SERVER, TSC]

This required qualifier determines the entities for which collection should be enabled or disabled.

/NAME=[\*,entity-name]

This qualifier specifies particular instances of an entity. Wildcards (\*) are allowed in names.

For ACC, AGENT, CP, QTI, and TSC entity types, the entity name is the process name. For the EXC entity, the entity name is the name of the application (for example, VR\_APPL).

Server and task group names can be specified as compound names made up of application name and server or task group name, separated by a period (for example, VR\_APPL.VR\_READ\_SERVER). Either part of server or task group names can be a wildcard (for example, \*.VR\_READ\_SERVER or VR\_APPL.\*). If only one part of a server or task group name is specified, it is assumed to be the application name, and a wildcard is used as the server or task group name. For example, VR\_APPL is equivalent to VR\_APPL.\*.

The default is all (\*), which is equivalent to \*.\* for a compound name.

`/STORAGE_END_TIME=[NEVER,time]`

This qualifier specifies a time after which the collection data should no longer be written to the snapshot file. The format of *time* is *DD-MMM-YY:hh:mm:ss.nn*. Partial dates and times (for example, 10-OCT or 09:00) are supported. The keyword NEVER is also supported, which equates to the OpenVMS zero date of 17-NOV-1858 00:00:00.00. With a value of NEVER, collection data continues to be written to the snapshot file until the storage state is set to DISABLED.

If this qualifier is not specified, the existing value remains unchanged. This value can be modified dynamically.

`/STORAGE_INTERVAL=value`

This qualifier controls the frequency (in seconds) at which data snapshots are performed.

The storage interval value should be a multiple of the timer interval parameter (SET PARAMETER/TIMER\_INTERVAL). The timer interval value determines the minimum elapsed time for many Remote Manager parameters, including the storage interval setting. The relationship of these values determine how often data snapshots are performed, for example:

- If the timer interval value is greater, its value is used by default. For instance, if the timer interval is 10 and the storage interval is 5, snapshots will be written at 10 second intervals.
- If the storage interval value is greater and is a multiple of the timer interval, the storage interval value is used. For example, if the timer interval is 10 and the storage interval is 30, snapshots will be written at 30 second intervals.
- If the storage interval value is greater and is not a multiple of the timer interval, the next multiple of the timer interval value is used. For example, if the timer interval is 10 and the storage interval is 15, snapshots will be written at 20 second intervals.

`/STORAGE_LOCATION=file-name`

This qualifier specifies an OpenVMS file specification to which collection data is to be written. The format of *file-name* is a valid OpenVMS pathname or logical (such as DISK\$1: [SYSTEM.SNAPSHOTS] or SYSS\$SYSTEM:SNAPSHOTS.DAT).

If the `/STORAGE_LOCATION` qualifier is not specified, the current value remains unchanged. If a directory is not provided as part of the specification, the file is written to the default directory of the account under which the Remote Manager process is running.

Multiple collections can share a single snapshot file or be stored in separate files. For continuity, HP recommends that EXC, Server, and Task Group collection information be written to the same snapshot file.

This value can be modified dynamically.

`/STORAGE_BEGIN_TIME=time`

This qualifier specifies a time after which the collection data should be written to the snapshot file. The format of *time* is *DD-MMM-YY:hh:mm:ss.nn*. Partial dates and times (for example, 10-OCT or 09:00) are supported. The keyword NOW is also supported, which equates to the OpenVMS zero date of 17-NOV-1858 00:00:00.00. With a value of NOW, collection data is written to the snapshot file immediately, or as soon as the storage state is set to ENABLED.

If this qualifier is not specified, the current value remains unchanged. This value can be modified dynamically.

`/STORAGE_STATE=[ENABLED, DISABLED]`

This qualifier specifies the state of the data snapshots. To fully enable data snapshots, both the storage state and the collection state (`/COLL_STATE`) must be set to `ENABLED`. If this qualifier is not specified, the current value remains unchanged. This value can be modified dynamically.

## Notes

When updating collection records, the combination of class, entity, and name must exactly match a record in the collection table.

By default, processes collect only ID and CONFIG class data during process initialization. If these classes were disabled during process startup, that information would not be available until the class was enabled and the process was restarted.

ACMS processes read the Collection table during process startup to determine which classes to begin collecting. Once the Remote Manager has been started, the `ACMSMGR SHOW PROCESS` command can be used to determine the class states for the currently running ACMS processes.

In order for collection data to be written to a snapshot file, the following conditions must be met:

- A qualifying entity must be running (one with an entity type and name matching fields in the Collection table).
- The collection state and storage state for that entity must be enabled.
- The current time must fall between the storage start time and storage end time.

If all these conditions are met, the Remote Manager opens the snapshot file for shared write operations. The file remains open until the storage state is set to `DISABLED` or until the snapshot period expires.

Changes to snapshot values are processed dynamically. Updated storage interval and storage state values are applied immediately; updated storage location and storage end time values are applied during the next snapshot interval.

When multiple collection records apply to a given process, the records are assigned weights according to a precedence of name, then entity, and then class. Within a column, wildcard entries are weighted less than nonwildcard entries. The row with the highest weight that applies to a process is used. The command `ACMSMGR SHOW COLLECTION` displays weights for each row in the table. See Section 5.1.1 for a discussion of the Collection table and how weights are assigned.

In contrast to typical collections, weighting for data snapshot threads does not apply. Therefore, it is possible for redundant collection data to be written to one or more snapshot files. If multiple collection records compile overlapping data, and each has their storage state set to `ENABLED`, each record writes data to the designated snapshot file.

## Examples

```
$ ACMSCFG SET COLLECTION/ENTITY=EXC/CLASS=RUNTIME/NAME=VR_APPL/  
COLL_STATE=DISABLED
```



This command disables run-time data collection for the VR\_APPL application.

## ACMSCFG SET INTERFACE

ACMSCFG SET INTERFACE — Allows Remote Manager interfaces to be enabled or disabled in the configuration file.

### Format

ACMSCFG SET INTERFACE [/qualifiers]

Command Qualifier	Default
/INTERFACE=interface	None
/STATE=keyword	DISABLED

### Privileges Required

None.

### Parameters

None.

### Qualifiers

/INTERFACE=interface

This required qualifier determines which interface to modify. Valid values are:

- RPC
- SNMP

/STATE=[DISABLED, ENABLED]

This qualifier determines the operation to perform. If the value supplied is ENABLED, the interface will be started (if it is not already running). If the value supplied is DISABLED, the interface will be stopped.

### Notes

The ACMSCFG uses the RPC interface. Stopping an interface disables communication to the Remote Manager through that interface. Stopping the RPC interface on a given node prevents ACMSCFG from communicating with the Remote Manager on that node.

### Examples

```
$ ACMSCFG SET INTERFACE/INTERFACE=SNMP/STATE=DISABLED
ACMS Remote Management Option -- Command line utility
Call to modify interface on server sparks was executed
```

```
%ACMSMGMT-S-SUCCESS, Operation completed
```

## ACMSCFG SET PARAMETER

ACMSCFG SET PARAMETER — Allows Remote Manager parameters to be updated in the configuration file.

### Format

**ACMSMGR SET PARAMETER [/qualifiers]**

Command Qualifier	Default
/DCL_AUDIT_LEVEL=value	None
/DCL_MGR_PRIORITY=value	None
/DCL_STACKSIZE=value	None
/ERROR_INTERVAL=value	None
	Only for use on systems running ACMS Version 4.4 or higher.
/EVENT_LOG_PRIORITY=value	None
/LOG_STACKSIZE=value	None
/LOGIN_CREDS_LIFETIME=value	None
/MAX_LOGINS=value	None
/MAX_RPC_RETURN_RECS=value	None
/MGR_AUDIT_LEVEL=value	None
/MSG_PROC_AUDIT_LEVEL=value	None
/MSG_PROC_PRIORITY=value	None
/MSG_PROC_STACKSIZE=value	None
/MSS_COLL_INTERVAL=value	None
/PROC_MON_AUDIT_LEVEL=value	None
/PROC_MON_INTERVAL=value	None
/PROC_MON_PRIORITY=value	None
/PROC_MON_STACKSIZE=value	None
/PROXY_CREDS_LIFETIME=value	None
/RPC_AUDIT_LEVEL=value	None
/RPC_PRIORITY=value	None
/RPC_STACKSIZE=value	None
/SECURITY_AUDIT_LEVEL=value	None
/SNAP_AUDIT_LEVEL=value	None
	Only for use on systems running ACMS Version 4.4 or higher.
/SNAP_PRIORITY=value	None

Command Qualifier	Default
	Only for use on systems running ACMS Version 4.4 or higher.
/SNAP_STACKSIZE=value	None Only for use on systems running ACMS Version 4.4 or higher.
/SNMP_AGENT_TIME_OUT	None
/SNMP_ARE_YOU_THERE=value	None
/SNMP_AUDIT_LEVEL=value	None
/SNMP_PRIORITY=value	None
/SNMP_SEL_TIME_OUT=value	None
/SNMP_STACKSIZE=value	None
/TCP_ENABLED=value	None Only for use on systems running ACMS Version 4.4 or higher.
/TIMER_AUDIT_LEVEL=value	None
/TIMER_INTERVAL=value	None
/TIMER_PRIORITY=value	None
/TIMER_STACKSIZE=value	None
/TOTAL_ENTITY_SLOTS=value	None
/TRACE_MSG_WAIT_TIME=value	None
/TRACE_START_WAIT_TIME=value	None
/TRAP_AUDIT_LEVEL=value	None
/TRAP_PRIORITY=value	None
/TRAP_STACKSIZE=value	None
/UDP_ENABLED=value	None Only for use on systems running ACMS Version 4.4 or higher.
/VMS_COLL_INTERVAL=value	None Only for use on systems running ACMS Version 4.4 or higher.
/WKSP_COLL_INTERVAL=value	None
/MAX_AGENTS=value	None

## Privileges Required

None.

## Parameters

None.

## Qualifiers

/[parameter]=value

All qualifiers correspond directly to fields in the Parameter table. See Section 9.9.1 for descriptions of each field.

## Notes

See Section 9.9 for a description of each parameter.

## Example

```
$ ACMSCFG SET PARAMETER /MGR_AUDIT_LEVEL=E
```

This command modifies the dynamic parameter field mgr\_audit\_level.

## ACMSCFG SET TRAP

ACMSCFG SET TRAP — Updates records in the Trap table in the configuration file.

## Format

ACMSCFG SET TRAP [/qualifiers]

Command Qualifier	Default
/ENTITY=keyword	None
/NAME=[*,entity-name]	* (all )
/PARAMETER=keyword	EXISTS
/SEVERITY=[I,W,E,F]	None
/TRAP_MIN=value	None
/TRAP_MAX=value	None

## Privileges Required

None.

## Parameters

None.

## Qualifiers

/ENTITY=[\*, ACC, CP, EXC, MGR, QTI, TSC]

This required qualifier determines the entity or entities for which a trap should be set.

/NAME=[\*,entity-name]

This qualifier specifies particular instances of an entity. Specify the value of the name field for the record you wish to modify.

`/PARAMETER=[EVENT_SEVERITY, EXISTS]`

The field that should be monitored. Valid values are:

- `EVENT_SEVERITY`

This parameter is used for monitoring internal Remote Manager events. The Remote Manager logs internal events in the Remote Manager log. (See Section 4.7 and Section 11.35 for discussions of the Remote Manager log.) Traps can be generated based on the severity levels of these events.

- `EXISTS`

This parameter is used for monitoring process existence. Traps are generated if the associated entity type and name either starts or stops.

`/SEVERITY=[I,W,E,F]`

A severity to be associated with the trap. Severity codes are embedded in the trap message and must be parsed by the trap receiver. Severities are informational (I), warning (W), error (E), and fatal (F).

`/TRAP_MIN=value`

This qualifier specifies the minimum allowable value for the parameter being monitored. A trap is generated if the parameter value is less than the minimum value. See Table 9.12 for a list of valid values.

`/TRAP_MAX=value`

This qualifier specifies the maximum allowable value for the parameter being monitored. A trap is generated if the parameter value is greater than the maximum value. See Table 9.12 for a list of valid values.

## Notes

When updating trap records, the combination of entity, name, and parameter must exactly match a record in the trap table.

See Section 9.14.2 for a discussion about setting appropriate trap minimums and maximums. See Section 9.14.3 for a description of the trap message generated.

## Examples

```
$ ACMSCFG SET TRAP /ENTITY=QTI/PARAMETER=EXISTS/TRAP_MAX=0
```

This command causes an SNMP trap to be generated whenever the QTI process is started if the SNMP interface is running.

## ACMSCFG SHOW COLLECTION

`ACMSCFG SHOW COLLECTION` — Displays Collection table data from the configuration file.

### Format

`ACMSCFG SHOW COLLECTION [/qualifiers]`

## Privileges Required

None.

## Parameters

None.

## Qualifier

[/BRIEF,FULL]

This qualifier causes either summary (/BRIEF) or detailed (/FULL) information to be displayed. The default is /BRIEF.

Note that storage start and end times for data snapshots are only visible when /FULL is provided. When not specified, the resulting summary display may contain truncated values for some of the longer fields (such as, entity name and storage location).

## Notes

See Section 9.4 for a discussion of each field displayed. See Section 5.1 for a discussion of collections.

## Examples

```
$ ACMSCFG SHOW COLLECTION
Entity          Collect  Collect          Storage
Storage
Type   Entity Name  Class   State   Storage location  State
Interval
-----
-----
*      *           id      enabled acms$mgmt_snapshot  enabled
3600
*      *           config  enabled acms$mgmt_snapshot  disabled
3600
*      *           runtime enabled acms$mgmt_snapshot  disabled 10
*      *           pool    enabled acms$mgmt_snapshot  disabled 10
*      *           error   enabled acms$mgmt_snapshot  disabled 10
```

This command shows the current contents of the Collection table as stored in the configuration file.

## ACMSCFG SHOW CONTROL

ACMSCFG SHOW CONTROL — Displays the control record from the configuration file.

### Format

ACMSCFG SHOW CONTROL

## Privileges Required

None.

## Parameters

None.

## Qualifiers

None.

## Notes

The control record is used by the Remote Manager and cannot be modified or deleted. The ACMSCFG SHOW CONTROL command displays the following fields:

- Interface count — Number of interface records in the file.
- Collection count — Number of collection records in the file.
- Timer count — Number of timer records in the file.
- Trap count — Number of trap records in the file.
- Parameter count — Number of parameter records in the file.
- Version — Internal file version identifier.

## Examples

```
$ ACMSCFG SHOW CONTROL
Record Counts
  Record type  Count
-----  -----
Interface      2
Collection     2
Timer          1
Trap           1
Parameter      1
Version        6
```

This command shows the current contents of the control record in the configuration file.

## ACMSCFG SHOW INTERFACE

ACMSCFG SHOW INTERFACE — Displays the Remote Manager interface from the configuration file.

### Format

ACMSCFG SHOW INTERFACE

### Privileges Required

None.

### Parameters

None.

## Qualifiers

None.

## Notes

The Remote Manager supports two interfaces: RPC and SNMP. This command displays the enabled states of each interface.

See Section 9.7 for a discussion of each field displayed.

## Examples

```
$ ACMSCFG SHOW INTERFACE
Interface      Enable
Type          State
-----
rpc           enabled
snmp         enabled
```

This command shows the current contents of the Interfaces table in the configuration file. As shown, both interfaces are started when the Remote Manager is started.

## ACMSCFG SHOW PARAMETER

ACMSCFG SHOW PARAMETER — Displays Remote Manager parameter information from the configuration file.

## Format

ACMSCFG SHOW PARAMETER

## Privileges Required

None.

## Parameters

None.

## Qualifiers

None.

## Notes

See Section 9.9 for a description of each parameter.

## Examples

```
$ ACMSCFG SHOW PARAMETER
Management Parameters
Parameter          Value  Default Min    Max    (D)ynamic
-----
dcl_audit_level    E      E      0      F      (D)
```



dcl_mgr_priority	5	5	1	10	
dcl_stacksize (Alpha)	300	300	1	2147483647	k (Vax), 8k
error_interval	10	10	1	863999999	seconds (D)
event_log_priority	5	5	1	10	
log_stacksize (Alpha)	300	300	1	2147483647	K (Vax), 8k
login_creds_lifetime	60	60	1	14399999	minutes (D)
max_logins	20	20	1	2147483647	(D)
max_rpc_return_recs	20	20	1	2147483647	
mgr_audit_level	E	E	0	F	(D)
msg_proc_audit_level	E	E	0	F	(D)
msg_proc_priority	5	5	1	10	
msg_proc_stacksize (Alpha)	300	300	1	2147483647	k (Vax), 8k
mss_coll_interval	10	10	1	863999999	seconds (D)
proc_mon_audit_level	E	E	0	F	(D)
proc_mon_interval	30	30	1	14399999	seconds (D)
proc_mon_priority	5	5	1	10	
proc_mon_stacksize (Alpha)	300	300	1	2147483647	K (Vax), 8k
proxy_creds_lifetime	60	60	1	14399999	minutes (D)
rpc_audit_level	E	E	0	F	(D)
rpc_priority	5	5	1	10	
rpc_stacksize (Alpha)	300	300	1	2147483647	k (Vax), 8k
security_audit_level	E	E	0	F	(D)
snap_audit_level	E	E	0	F	(D)
snap_priority	5	5	1	10	
snap_stacksize (Alpha)	30	30	1	2147483647	k (Vax), 8k
snmp_agent_time_out	10	10	1	863999999	seconds
snmp_are_you_there	300	300	2	863999999	seconds
snmp_audit_level	E	E	0	F	(D)
snmp_priority	5	5	1	10	
snmp_sel_time_out	5	5	1	863999999	seconds
snmp_stacksize (Alpha)	300	300	1	2147483647	k (Vax), 8k
tcp_enabled 1=enabled	1	1	0	1	[0,1]
timer_audit_level	E	E	0	F	(D)
timer_interval	30	30	1	863999999	seconds (D)
timer_priority	5	5	1	10	
timer_stacksize (Alpha)	300	300	1	2147483647	k (Vax), 8k
total_entity_slots	20	20	1	2147483647	
trace_msg_wait_time	5	5	1	14399999	seconds (D)
trace_start_wait_time	5	5	1	14399999	seconds (D)
trap_audit_level	E	E	0	F	(D)
trap_priority	5	5	1	10	
trap_stacksize (Alpha)	300	300	1	2147483647	k (Vax), 8k
udp_enabled 1=enabled	1	1	0	1	[0,1]
vms_coll_interval	10	10	0	863999999	seconds (D)
wksp_coll_interval	10	10	1	863999999	seconds (D)

This command shows the current contents of the Parameter table in the configuration file.

## ACMSCFG SHOW TRAP

ACMSCFG SHOW TRAP — Displays SNMP trap configurations from the configuration file.

### Format

ACMSCFG SHOW TRAP

### Privileges Required

None.

### Parameters

None.

### Qualifiers

None.

### Notes

SNMP traps are generated only if the SNMP interface is started.

See Section 9.13 for a description of each field displayed.

### Example

```
$ ACMSCFG SHOW TRAP
Entity  Entity
Type   Name
-----
*      *
exists 1      -1      i
```

This command shows the current contents of the Trap table in the configuration file. As shown, a single trap has been configured to send an informational trap when any ACMS process is stopped. This is the default configuration.

# Chapter 11. ACMSMGR Commands

This chapter provides reference information about the commands for the ACMSMGR utility.

## 11.1. ACMSMGR Overview

The ACMSMGR utility is used to perform operations on running ACMS systems.

You can use the ACMSMGR utility to perform the following functions:

- User authentication (login, logout)
- Display and update ACMS system management data
- Manage the ACMS Remote Manager

The ACMSMGR utility uses the ACMS management interface, which is based on ONC RPC. Commands can be executed remotely from any node in the network, and many commands can be executed against more than one node.

See Chapter 4 for a description of how to use ACMSMGR to manage the Remote Manager.

### 11.1.1. Command Format

The format for ACMSMGR commands is as follows:

```
ACMSMGR verb object qualifiers
```

The following verbs are supported:

- ADD
- DELETE
- HELP
- LOGIN
- LOGOUT
- REPLACE
- RESET
- SET
- SHOW
- START
- STOP

Each verb has an associated object and set of qualifiers.

### 11.1.2. Command Objects and Qualifiers

The objects and qualifiers for the ACMSMGR commands are summarized in the table below.

**Table 11.1. ACMSMGR Command Objects and Qualifiers**

Objects	Qualifiers
ADD Command	
COLLECTION	/CLASS, /COLL_STATE, /ENTITY, / NAME, /NODE, /STORAGE_END_TIME, / STORAGE_INTERVAL, / STORAGE_LOCATION, / STORAGE_BEGIN_TIME, / STORAGE_STATE, /USER
FILTER	/CODE, /FILE, /NAME, /NODE, /USER
TRAP	/ENTITY, /NAME, /NODE, /PARAMETER, / SEVERITY, /TRAP_MIN, /TRAP_MAX, /USER
DELETE Command	
COLLECTION	/CLASS, /ENTITY, /NAME, /NODE, /USER
FILTER	/CODE, /NAME, /NODE, /USER
TRAP	/ENTITY, /NAME, /NODE, /PARAMETER, / USER
HELP Command	
None	None
LOGIN Command	
None	/NODE, /PASSWORD, /USER
LOGOUT Command	
None	/NODE, /USER
REPLACE Command	
SERVER	/APPLICATION, /NODE, /SERVER, /USER
RESET Command	
ERROR	/NODE, /USER
LOG	/NODE, /USER
SAVE Command	
FILTER	/FILE, /NODE, /USER
SET Command	
ACC	/ACC_PRIORITY, /ACC_USERNAME, / ACTIVE, /ASTLM, /AUDIT_STATE, / BIOLM, /BYTLM, /CHANNELCNT, / DIOLM, /ENQLM, /FILLM, /GBLPAGES, / GBLPAGFIL, /GBLSECTIONS, / LOG, /MAX_APPL, /MSS_MAXBUF, / MSS_MAXOBJ, /MSS_NET_RETRY_TIMER, / MSS_POOLSIZ, /MSS_PROCESS_POOL, / NODE, /NODE_NAME, /PGFLQUOTA, / STORED, /TQELM, /TWS_POOLSIZ, / TWSC_POOLSIZ, /USER, / USERNAME_DEFAULT, /WS_POOLSIZ, /

	WSC_POOLSIZE, /WSDEFAULT, /WSEXTENT, /WSQUOTA
COLLECTION	/CLASS, /COLL_STATE, /ENTITY, /NAME, /NODE, /STORAGE_END_TIME, /STORAGE_INTERVAL, /STORAGE_LOCATION, /STORAGE_START_TIME, /STORAGE_STATE, /USER
CP	/ASTLM, /BIOLM, /BYTLM, /DIOLM, /ENQLM, /FILLM, /LOG /PGFLQUOTA, /TQELM, /WSEXTENT, /WSDEFAULT, /WSQUOTA
EXC	/ACTIVE, /APPLICATION, /ASTLM, /AUDIT_STATE, /BIOLM, /BYTLM, /DIOLM, /ENQLM, /FILLM, /LOG, /MAX_SERVERS, /MAX_TASKS, /NODE, /PGFLQUOTA, /SP_MON_INTERVAL, /STORED, /TQELM, /TRANSACTION_TIMEOUT, /USERNAME, /WSEXTENT, /WSDEFAULT, /WSQUOTA
INTERFACE	/INTERFACE, /NODE, /STATE, /USER
PARAMETER	/DCL_AUDIT_LEVEL, /DCL_MGR_PRIORITY, /DCL_STACKSIZE, /ERROR_INTERVAL /EVENT_LOG_PRIORITY, /LOG_STACKSIZE, /LOGIN_CREDS_LIFETIME, /MAX_LOGINS, /MAX_RPC_RETURN_RECS, /MGR_AUDIT_LEVEL, /MSG_PROC_AUDIT_LEVEL, /MSG_PROC_PRIORITY, /MSG_PROC_STACKSIZE, /MSS_COLL_INTERVAL, /NODE, /PROC_MON_AUDIT_LEVEL, /PROC_MON_INTERVAL, /PROC_MON_PRIORITY, /PROC_MON_STACKSIZE, /PROXY_CREDS_LIFETIME, /RPC_AUDIT_LEVEL, /RPC_PRIORITY, /RPC_STACKSIZE, /SECURITY_AUDIT_LEVEL, /SNAP_AUDIT_LEVEL, /SNAP_PRIORITY, /SNAP_STACKSIZE, /SNMP_AGENT_TIME_OUT, /SNMP_ARE_YOU_THERE, /SNMP_AUDIT_LEVEL, /SNMP_PRIORITY, /SNMP_SEL_TIME_OUT, /SNMP_STACKSIZE, /TCP_ENABLED, /TIMER_AUDIT_LEVEL, /TIMER_INTERVAL, /TIMER_PRIORITY, /TIMER_STACKSIZE, /TOTAL_ENTITY_SLOTS, /

	TRACE_MSG_WAIT_TIME, / TRACE_START_WAIT_TIME, / TRAP_AUDIT_LEVEL, /TRAP_PRIORITY, / TRAP_STACKSIZE, /UDP_ENABLED, / USER, /VMS_COLL_INTERVAL, WKSP_COLL_INTERVAL
QTI	/ACTIVE, /ASTLM, /BIOLM, /BYTLM, / DIOLM, /ENQLM, /FILLM, /LOG, /NODE, / PGFLQUOTA, /POLLING_TIMER, / QTI_PRIORITY, /QTI_USERNAME, / RETRY_TIMER, /STORED, /SUB_TIMEOUT, / TQELM, /WSEXTENT, /WSDEFAULT, / WSQUOTA, /USER
SERVER	/APPLICATION, /CREATION_DELAY, / CREATION_INTERVAL, / DELETION_DELAY, / DELETION_INTERVAL, /LOG, / MAX_INSTANCE, /MIN_INSTANCE, / NODE, /SERVER, /SP_DUMP_FLAG, /USER
TRAP	/ENTITY, /NAME, /NODE, /PARAMETER, / SEVERITY, /TRAP_MIN, /TRAP_MAX, /USER
TSC	/ACTIVE, /ASTLM, /BIOLM, / BYTLM, /CP_PRIORITY, /CP_SLOTS, / CP_USERNAME, /DIOLM, /ENQLM, / FILLM, /LOG, /MAX_LOGINS, / MAX_TTS_CP, /MIN_CPIS, /NODE, / PERM_CPS, /PGFLQUOTA, / STORED, /TQELM, /TSC_PRIORITY, / TSC_USERNAME, /USER, /WSEXTENT, / WSDEFAULT, /WSQUOTA
SHOW Command	
ACC	/ACTIVE, /BRIEF, /CONFIG, /ERROR, / FULL, /ID, /INTERVAL, /NODE, /OUT, / POOL, /RUNTIME, /STORED, /USER
COLLECTION	/BRIEF, /FULL, /INTERVAL, /NODE, /OUT, / USER
CP	/ACTIVE, /ALL, /BRIEF, /CONFIG, /ERROR, / FULL, /ID, /INTERVAL, /NODE, /OUT, / POOL, /PROCESS_NAME, /RUNTIME, / STORED, /USER
ERROR	/BEFORE, /FILENAME, /INTERVAL, / LOCAL, /NODE, /OUT, /SEVERITY, /SINCE, / USER
EXC	/ACTIVE, /ALL, /APPLICATION, /BRIEF, / CONFIG, /ERROR, /FULL, /ID, /INTERVAL, / NODE, /OUT, /POOL, /RUNTIME, /STORED, / USER
FILTER	/NODE, /USER

GROUP	/APPLICATION, /BRIEF, /FULL, /GROUP, /ID, /INTERVAL, /NODE, /OUT, /POOL, /USER
INTERFACE	/INTERVAL, /NODE, /OUT, /USER
LOG	/BEFORE, /FACILITY, /FILENAME, /INTERVAL, /LOCAL, /NODE, /OUT, /SEVERITY, /SINCE, /USER
MANAGER	/INTERVAL, /NODE, /OUT, /USER
PARAMETER	/INTERVAL, /NODE, /OUT, /USER
PROCESS	/ALL, /BRIEF, /FULL, /INTERVAL, /NODE, /OUT, /USER
QTI	/ACTIVE, /ALL, /BRIEF, /CONFIG, /ERROR, /FULL, /ID, /INTERVAL, /NODE, /OUT, /POOL, /RUNTIME, /STORED, /USER
SERVER	/APPLICATION, /BRIEF, /CONFIG, /FULL, /ID, /INTERVAL, /NODE, /OUT, /RUNTIME, /SERVER, /USER
TRAP	/INTERVAL, /NODE, /OUT, /USER
TSC	/ACTIVE, /ALL, /BRIEF, /CONFIG, /ERROR, /FULL, /ID, /INTERVAL, /NODE, /OUT, /POOL, /RUNTIME, /STORED, /USER
USER	/BRIEF, /FULL, /INTERVAL, /NODE, /OUT, /USER
VERSION	None.
START Command	
EXC	/APPLICATION, /NODE, /USER
QTI	/NODE, /USER
SYS	/NOAUDIT, /NODE, /QTI, /NOTERMINALS, /USER
TERMINALS	/NODE, /USER
TRACE_MONITOR	/NODE, /USER
STOP Command	
EXC	/APPLICATION, /CANCEL, /NODE, /USER
MANAGER	/NODE, /USER
QTI	/NODE, /USER
SYS	/CANCEL, /NODE, /USER
TERMINALS	/NODE, /USER
TRACE_MONITOR	/NODE, /USER

## 11.2. ACMSMGR ADD COLLECTION

### ACMSMGR ADD COLLECTION

ACMSMGR ADD COLLECTION — Adds records to the Collection table.

## Format

### ACMSMGR ADD COLLECTION [/qualifiers]

Command Qualifier	Default
/CLASS=class-name	* (all)
/COLL_STATE=keyword	DISABLED
/ENTITY=keyword	Qualifier is required
/NAME=[*,entity-name]	* (all)
/NODE=node-name	Translation of logical ACMS \$MGMT_SERVER_NODE
/STORAGE_END_TIME=[NEVER, /time]	NEVER; run until DISABLED
/STORAGE_INTERVAL=value	300
/STORAGE_LOCATION=file-name	Translation of logical ACMS \$MGMT_SNAPSHOT
/STORAGE_START_TIME=[NOW, /time]	NOW; start as soon as ENABLED
/STORAGE_STATE=keyword	DISABLED
/USER=user-name	Translation of logical ACMS\$MGMT_USER

## Privileges Required

ACMS\$MGMT\_WRITE

## Parameters

None.

## Qualifiers

/CLASS=[\*, ERROR, POOL, RUNTIME]

This qualifier specifies the class to be enabled or disabled. The default is \* (all). See Section 5.1.1 for a description of each class type.

/COLL\_STATE=[ENABLED, DISABLED]

This qualifier specifies the state of the collection. The default is DISABLED. When a SHOW entity command is issued, data for those classes that have their collection state set to ENABLED is displayed. Note that while the collection state is DISABLED, the data displayed for an entity may not be accurate. Data cannot be written to the data snapshot file when this qualifier is DISABLED, even when the storage state is ENABLED.

/ENTITY=[\*, ACC, AGENT, CP, EXC, GROUP, QTI, SERVER, TSC]

This required qualifier specifies the entity for which collection should be enabled or disabled.

/NAME=[\*, entity-name]

This qualifier specifies particular instances of an entity. Wildcards (\*) are allowed in names.



For ACC, AGENT, CP, QTI, and TSC entity types, the entity name is the process name. For the EXC entity type, the entity name is the name of the application (for example, VR\_APPL).

Server and task group names can be specified as compound names made up of an application name and a server or task group name, separated by a period (for example, VR\_APPL.VR\_READ\_SERVER). Either part of server or task group names can be a wildcard (for example, \*.VR\_READ\_SERVER or VR\_APPL.\*). If only one part of a server or task group name is specified, it is assumed to be the application name, and the server or task group name is wildcarded. For example, VR\_APPL is equivalent to VR\_APPL.\*.

The default is all ( \* ), which is equivalent to \*.\* for a compound name.

`/NODE=node-name`

This qualifier specifies a fully- or partially-qualified TCP/IP host name. This name must match the current DECnet host name. IP addresses and host names (or aliases) that exceed six characters or include mixed case are not allowed.

To execute the command on more than one node, you can specify the node names in a comma-separated list. The ACMSMGR utility attempts to perform the operation sequentially on each node in the list.

If the `/NODE` qualifier is not specified, the ACMSMGR utility checks for the presence of the logical name `ACMS$MGMT_SERVER_NODE`. If the logical is defined, the value of the logical is used by default.

In order for the command to execute, either the `/NODE` qualifier must be provided on the command line, or the `ACMS$MGMT_SERVER_NODE` logical must be defined.

`/STORAGE_END_TIME=[NEVER, time]`

This qualifier specifies a time after which the collection data should no longer be written to the snapshot file. The format of *time* is *DD-MMM-YY:hh:mm:ss.nn*. Partial dates and times (for example, 10-OCT or 09:00) are supported. If this qualifier is not specified, the default keyword of NEVER is applied, which equates to the OpenVMS zero date of 17-NOV-1858 00:00:00.00. With a value of NEVER, collection data continues to be written to the snapshot file until the storage state is set to DISABLED.

`/STORAGE_INTERVAL=value`

This qualifier controls the frequency (in seconds) at which data snapshots are performed. The default value is 300 seconds.

The storage interval value should be a multiple of the timer interval parameter (`SET PARAMETER/TIMER_INTERVAL`). The timer interval value determines the minimum elapsed time for many Remote Manager parameters, including the storage interval setting. The relationship of these values determine how often data snapshots are performed, for example:

- If the timer interval value is greater, its value is used by default. For instance, if the timer interval is 10 and the storage interval is 5, snapshots will be written at 10 second intervals.
- If the storage interval value is greater and is a multiple of the timer interval, the storage interval value is used. For example, if the timer interval is 10 and the storage interval is 30, snapshots will be written at 30 second intervals.

- If the storage interval value is greater and is not a multiple of the timer interval, the next multiple of the timer interval value is used. For example, if the timer interval is 10 and the storage interval is 15, snapshots will be written at 20 second intervals.

`/STORAGE_LOCATION=file-name`

This qualifier specifies an OpenVMS file specification to which collection data is to be written. The format of *file-name* is a valid OpenVMS pathname or logical (such as DISK\$1:[SYSTEM.SNAPSHOTS] or SYSS\$SYSTEM:SNAPSHOTS.DAT).

If the `/STORAGE_LOCATION` qualifier is not specified, the ACMSMGR utility checks for the presence of the logical name ACMS\$MGMT\_SNAPSHOT. If the logical is defined, the value of the logical is used by default. If a directory is not provided as part of the specification, the file is written to the default directory of the account under which the Remote Manager process is running.

Multiple collections can share a single snapshot file or be stored in separate files. For continuity, HP recommends that EXC, Server, and Task Group collection information be written to the same snapshot file.

`/STORAGE_BEGIN_TIME=[NOW, time]`

This qualifier specifies a time after which the collection data should be written to the snapshot file. The format of *time* is *DD-MMM-YY:hh:mm:ss.nn*. Partial dates and times (for example, 10-OCT or 09:00) are supported. If this qualifier is not specified, the default keyword of NOW is applied, which equates to the OpenVMS zero date of 17-NOV-1858 00:00:00.00. With a value of NOW, collection data is written to the snapshot file immediately, or as soon as the storage state is set to ENABLED.

`/STORAGE_STATE=[ENABLED, DISABLED]`

This qualifier specifies the state of the data snapshots. If this qualifier is not specified, data snapshots are disabled by default. To fully enable data snapshots, both the storage state and the collection state (`/COLL_STATE`) must be set to ENABLED.

`/USER=user-name`

This qualifier specifies the name of the OpenVMS account on the server node to be used for authorization. If this qualifier is specified, an explicit login must already have been completed successfully (see Section 11.10).

If the `/USER` qualifier is not specified, the ACMSMGR utility checks for the presence of the logical name ACMS\$MGMT\_USER. If the logical is defined, the value of the logical is used by default.

If the `/USER` qualifier is not specified and the ACMS\$MGMT\_USER logical is not defined, the ACMSMGR utility attempts proxy access. See Section 4.4.1.2 for a discussion of proxy access.

## Notes

When adding new collection records, the combination of class, entity, and name must be unique.

It is not possible to add records for the ID and CONFIG class. By default, all ACMS processes collect ID and CONFIG class data.

ACMS processes read the Collection table during process startup to determine which classes to begin collecting. Once the Remote Manager has been started, the ACMSMGR SHOW PROCESS command can be used to determine the class states for the currently running ACMS processes.

In order for collection data to be written to a snapshot file, the following conditions must be met:

- A qualifying entity must be running (one with an entity type and name matching fields in the Collection table).
- The collection state and storage state for that entity must be enabled.
- The current time must fall between the storage start time and storage end time.

If all these conditions are met, the Remote Manager opens the snapshot file for shared write operations. The file remains open until the storage state is set to DISABLED or until the snapshot period expires.

When multiple collection records apply to a given process, the records are assigned weights according to a precedence of name, then entity, and then class. Within a column, wildcard entries are weighted less than nonwildcard entries. The row with the highest weight that applies to a process is used. The command ACMSMGR SHOW COLLECTION displays weights for each row in the table. See Section 5.1.1 for a discussion of the Collection table and how weights are assigned.

In contrast to typical collections, weighting for data snapshot threads does not apply. Therefore, it is possible for redundant collection data to be written to one or more snapshot files. If multiple collection records compile overlapping data, and each has their storage state set to ENABLED, each record writes data to the designated snapshot file.

## Examples

```
$ ACMSMGR ADD COLL/ENT=EXC/CLASS=RUNTIME/NAME=VR_APPL
```

This command creates an entry in the Collection table. As a result of this command, the EXC entity for VR\_APPL will begin collecting run-time information; however this data will not be saved and written to the data snapshot file.

## 11.3. ACMSMGR ADD FILTER

### ACMSMGR ADD FILTER

ACMSMGR ADD FILTER — Adds records to the Remote Manager Error Filter table. This command (and its qualifiers) is only for use with systems running ACMS Version 4.4 or higher.

#### Format

ACMSMGR ADD FILTER [/qualifiers]

Command Qualifier	Default
/CODE=value	None.
/FILE=file-name	None.
/NAME=error-name	None.
/NODE=node-name	Translation of logical ACMS \$MGMT_SERVER_NODE

/USER=user-name	Translation of logical ACMS\$MGMT_USER
-----------------	--

## Privileges Required

ACMS\$MGMT\_WRITE

## Parameters

None.

## Qualifiers

/CODE=value

This qualifier specifies the decimal or hexadecimal value (such as, %x5258028) related to the error message being filtered.

/FILE=file-name

This qualifier specifies the name of an input file that contains a list of error filter values. The Remote Manager reads this file and adds each code or symbolic name to the Error Filter table.

/NAME=error-name

This qualifier specifies the symbolic name (such as, %ACMSACC-W-TCS\_LOADING) related to the error message being filtered.

/NODE=node-name

This qualifier specifies a fully- or partially-qualified TCP/IP host name. This name must match the current DECnet host name. IP addresses and host names (or aliases) that exceed six characters or include mixed case are not allowed.

To execute the command on more than one node, you can specify the node names in a comma-separated list. The ACMSMGR utility attempts to perform the operation sequentially on each node in the list.

If the /NODE qualifier is not specified, the ACMSMGR utility checks for the presence of the logical name ACMS\$MGMT\_SERVER\_NODE. If the logical is defined, the value of the logical is used by default.

In order for the command to execute, either the /NODE qualifier must be provided on the command line, or the ACMS\$MGMT\_SERVER\_NODE logical must be defined.

/USER=user-name

This qualifier specifies the name of the OpenVMS account on the server node to be used for authorization. If this qualifier is specified, an explicit login must already have been completed successfully (see Section 11.10).

If the /USER qualifier is not specified, the ACMSMGR utility checks for the presence of the logical name ACMS\$MGMT\_USER. If the logical is defined, the value of the logical is used by default.

If the /USER qualifier is not specified and the ACMS\$MGMT\_USER logical is not defined, the ACMSMGR utility attempts proxy access. See Section 4.4.1.2 for a discussion of proxy access.

## Notes

When adding new error filter records, you must specify either the /CODE, /NAME, or /FILE qualifier.

ACMS processes read the Error Filter table during process startup to determine which errors to refrain from sending to the Remote Manager server. Error filtering begins or ends immediately after filter records are added. The Remote Manager signals the appropriate ACMS process as soon as it has reevaluated the Error Filter table following an addition. Messages are sent to active ACMS processes using the ACMS Trace Monitor.

Certain system messages, such as event flags (ACMSACC-I-EVENT), often spawn further status messages indicating the cause of the event (ACMSACC-WFORCEOUT). Error filtering is explicit; that is, only the specified messages are suppressed. If you want to filter the initial and subsequent system messages, you must add each message to the Error Filter table.

Errors are also filtered using the command SET PARAMETER/ERROR\_INTERVAL=n. Any errors that are rebroadcast within the specified interval are not sent to the Remote Manager server. The command ACMSMGR SHOW PARAMETER can be used to determine the current error interval for ACMS systems.

## Examples

```
$ ACMSMGR ADD FILTER /NAME="ACMSACC-W-FORCEOUT" /NODE=SPARKS
```

This command adds the ACMS ACC force out warning message to the Error Filter table. If this message is generated by an ACMS process on node SPARKS, it is not relayed to the Remote Manager.

```
$ ACMSMGR ADD FILTER /FILE=DISK$1:[USER1]FILTER_ERR.DAT
```

This command adds all the system messages in the file FILTER\_ERR.DAT to the Error Filter table. These messages are no longer relayed to the Remote Manager.

# 11.4. ACMSMGR ADD TRAP

## ACMSMGR ADD TRAP

ACMSMGR ADD TRAP — Adds records to the Remote Manager Trap table.

### Format

ACMSMGR ADD TRAP [/qualifiers]

Command Qualifier	Default
/ENTITY=[*,entity-name]	Qualifier is required.
/NAME=[*,entity-name]	* (all)
/NODE=node-name	Translation of logical ACMS \$MGMT_SERVER_NODE
/PARAMETER=keyword	EXISTS
/SEVERITY=[I,W,E,F]	E
/TRAP_MIN=value	-1

/TRAP_MAX=value	-1
/USER=user-name	Translation of logical ACMS\$MGMT_USER

## Privileges Required

ACMS\$MGMT\_OPER

## Parameters

None.

## Qualifiers

/ENTITY=[\*, ACC, CP, EXC, MGR, QTI, TSC]

This required qualifier specifies the entity or entities for which a trap should be set.

/NAME=[\*, entity-name]

This qualifier specifies particular instances of an entity. Wildcards (\*) are allowed in names.

This field is ignored for the MGR entity.

For ACC, CP, QTI, and TSC entity types, the entity name is the process name. For the EXC entity type, the entity name is the name of the application (for example, VR\_APPL).

The default is all (\*).

/NODE=node-name

This qualifier specifies a fully- or partially-qualified TCP/IP host name. This name must match the current DECnet host name. IP addresses and host names (or aliases) that exceed six characters or include mixed case are not allowed.

If the /NODE qualifier is not specified, the ACMSMGR utility checks for the presence of the logical name ACMS\$MGMT\_SERVER\_NODE. If the logical is defined, the value of the logical is used by default.

In order for the command to execute, either the /NODE qualifier must be provided on the command line, or the ACMS\$MGMT\_SERVER\_NODE logical must be defined.

/PARAMETER=[EVENT\_SEVERITY, EXISTS]

This parameter specifies the field that should be monitored.

- EVENT\_SEVERITY

Internal Remote Manager events are to be monitored. The Remote Manager logs internal events in the Remote Manager log. (See Section 4.7 and Section 11.35 for discussions of the Remote Manager log.) Traps can be generated based on the severity levels of these events.

- EXISTS

Process existence is to be monitored. Traps are generated if the associated entity type and name either starts or stops.

`/SEVERITY=[I, W, E, F]`

This qualifier specifies the severity to be associated with the trap. Severity codes are embedded in the trap message and must be parsed by the trap receiver. Severities are informational (I), warning (W), error (E), or fatal (F).

`/TRAP_MIN=value`

This qualifier specifies the minimum allowable value for the parameter being monitored. A trap is generated if the parameter value is less than the minimum. See Section 9.14.2 for a list of valid values.

`/TRAP_MAX=value`

This qualifier specifies the maximum allowable value for the parameter being monitored. A trap is generated if the parameter value is greater than the maximum. See Section 9.14.2 for a list of valid values.

`/USER=user-name`

This qualifier specifies the name of the OpenVMS account on the server node to be used for authorization. If this qualifier is specified, an explicit login must already have been completed successfully (see Section 11.10).

If the `/USER` qualifier is not specified, the ACMSMGR utility checks for the presence of the logical name `ACMS$MGMT_USER`. If the logical is defined, the value of the logical is used by default.

If the `/USER` qualifier is not specified and the `ACMS$MGMT_USER` logical is not defined, the ACMSMGR utility attempts proxy access. See Section 4.4.1.2 for a discussion of proxy access

## Notes

When adding new trap records, the combination of entity, name, and parameter must be unique.

Traps become active as soon as they are added to the Trap table and the SNMP interface is running.

See Section 9.14.2 for a discussion about setting appropriate trap minimums and maximums. See also Section 9.14.3 for a description of the trap message generated.

## Examples

```
$ ACMSMGR ADD TRAP /ENT=ACC/PARAMETER=EXISTS/TRAP_MIN=1
```

This command causes an SNMP trap to be generated whenever the ACC process stops if the SNMP interface is running.

# 11.5. ACMSMGR DELETE COLLECTION

## ACMSMGR DELETE COLLECTION

ACMSMGR DELETE COLLECTION — Deletes records from the Collection table.

### Format

ACMSMGR DELETE COLLECTION [/qualifiers]

Command Qualifier	Default
/CLASS=class-name	* (all )
/ENTITY=[*,entity-name]	Qualifier is required.
/NAME=[*,entity-name]	* (all )
/NODE=node-name	Translation of logical ACMS \$MGMT_SERVER_NODE
/USER=user-name	Translation of logical ACMS\$MGMT_USER

## Privileges Required

ACMS\$MGMT\_WRITE

## Parameters

None.

## Qualifiers

/CLASS=[\*, CONFIG, ERROR, ID, POOL, RUNTIME]

This qualifier specifies the class to be enabled or disabled. The default is \* (all ). See Section 5.1.1 for a description of each class type.

/ENTITY=[\*, ACC, AGENT, CP, EXC, GROUP, QTI, SERVER, TSC]

This required qualifier specifies the entity or entities for which collection should be enabled or disabled.

/NAME=[\*, entity-name]

This qualifier specifies particular instances of an entity. Wildcards (\*) are allowed in names.

For ACC, AGENT, CP, QTI, and TSC entity types, the entity name is the process name. For the EXC entity type, the entity name is the name of the application (for example, VR\_APPL).

Server and task group names can be specified as compound names made up of an application name and a server or task group name, separated by a period (for example, VR\_APPL.VR\_READ\_SERVER). Either part of server or task group names can be a wildcard (for example, \*.VR\_READ\_SERVER or VR\_APPL.\*). If only one part of a server or task group name is specified, it is assumed to be the application name, and the server or task group name is wildcarded. For example, VR\_APPL is equivalent to VR\_APPL.\*.

The default is all ( \* ), which is equivalent to \*.\* for a compound name.

/NODE=node-name

This qualifier specifies a fully- or partially-qualified TCP/IP host name. This name must match the current DECnet host name. IP addresses and host names (or aliases) that exceed six characters or include mixed case are not allowed.

If the /NODE qualifier is not specified, the ACMSMGR utility checks for the presence of the logical name ACMS\$MGMT\_SERVER\_NODE. If the logical is defined, the value of the logical is used by default.



In order for the command to execute, either the `/NODE` qualifier must be provided on the command line, or the `ACMS$MGMT_SERVER_NODE` logical must be defined.

`/USER=user-name`

This qualifier specifies the name of the OpenVMS account on the server node to be used for authorization. If this qualifier is specified, an explicit login must already have been completed successfully (see Section 11.10).

If the `/USER` qualifier is not specified, the ACMSMGR utility checks for the presence of the logical name `ACMS$MGMT_USER`. If the logical is defined, the value of the logical is used by default.

If the `/USER` qualifier is not specified and the `ACMS$MGMT_USER` logical is not defined, the ACMSMGR utility attempts proxy access. See Section 4.4.1.2 for a discussion of proxy access.

## Notes

When deleting collection records, the combination of class, entity, and name must exactly match the row to be deleted. Deleting a collection record automatically terminates all related snapshot threads.

It is not possible to delete records for the ID and CONFIG class. By default, all ACMS processes collect ID and CONFIG class data.

Collections begin or end immediately after collection records are deleted. The Remote Manager signals the appropriate ACMS process as soon as it has reevaluated the Collection table following a deletion. Messages are sent to the ACMS process using the ACMS Trace Monitor.

ACMS processes read the Collection table during process startup to determine which classes to begin collecting.

The ACMSMGR SHOW PROCESS command can be used to determine the class states for the currently running ACMS processes.

## Examples

```
$ ACMSMGR DELETE COLL/ENT=EXC/CLASS=RUNTIME/NAME=VR_APPL
```

This command deletes the entry in the Collection table for run-time collection by the `VR_APPL` application. After the deletion, if there are no other Collection table entries that apply to the run-time class for `VR_APPL`, run-time collection is disabled.

# 11.6. ACMSMGR DELETE FILTER

## ACMSMGR DELETE FILTER

**ACMSMGR DELETE FILTER** — Removes records from the Remote Manager Error Filter table. This command (and its qualifiers) is only for use with systems running ACMS Version 4.4 or higher.

### Format

**ACMSMGR DELETE FILTER** [*qualifiers*]

Command Qualifier	Default
<code>/CODE=value</code>	None.

/NAME=error-name	None.
/NODE=node-name	Translation of logical ACMS\$MGMT_SERVER_NODE
/USER=user-name	Translation of logical ACMS\$MGMT_USER

## Privileges Required

ACMS\$MGMT\_WRITE

## Parameters

None.

## Qualifiers

/CODE=value

This qualifier specifies the hexadecimal value (such as, %x5258028) related to the error message being filtered.

/NAME=error-name

This required qualifier specifies the symbolic name (such as, %ACMSACC-WTCS\_LOADING) related to the error message being filtered.

/NODE=node-name

This qualifier specifies a fully- or partially-qualified TCP/IP host name. This name must match the current DECnet host name. IP addresses and host names (or aliases) that exceed six characters or include mixed case are not allowed.

If the /NODE qualifier is not specified, the ACMSMGR utility checks for the presence of the logical name ACMS\$MGMT\_SERVER\_NODE. If the logical is defined, the value of the logical is used by default.

In order for the command to execute, either the /NODE qualifier must be provided on the command line, or the ACMS\$MGMT\_SERVER\_NODE logical must be defined.

/USER=user-name

This qualifier specifies the name of the OpenVMS account on the server node to be used for authorization. If this qualifier is specified, an explicit login must already have been completed successfully (see Section 11.10).

If the /USER qualifier is not specified, the ACMSMGR utility checks for the presence of the logical name ACMS\$MGMT\_USER. If the logical is defined, the value of the logical is used by default.

If the /USER qualifier is not specified and the ACMS\$MGMT\_USER logical is not defined, the ACMSMGR utility attempts proxy access. See Section 4.4.1.2 for a discussion of proxy access.

## Notes

Either the /CODE or /NAME qualifier must be specified. When deleting error filter records, the combination of code (or name) and node must exactly match the row to be deleted.

ACMS processes read the Error Filter table during process startup to determine which errors to refrain from sending to the Remote Manager server. Error filtering ends immediately after filter records are deleted. The Remote Manager signals the appropriate ACMS process as soon as it has reevaluated the Error Filter table following a deletion. Messages are sent to active ACMS processes using the ACMS Trace Monitor.

Errors are also filtered using the command `SET PARAMETER/ERROR_INTERVAL=n`. Any errors that are rebroadcast within the specified interval are not sent to the Remote Manager server. The command `ACMSMGR SHOW PARAMETER` can be used to determine the current error interval for ACMS systems.

## Examples

```
$ ACMSMGR DELETE FILTER /NAME="ACMSACC-W-FORCEOUT" /NODE=SPARKS
```

This command deletes the ACMS ACC force out warning message from the Error Filter table. If this message is generated by an ACMS process on node SPARKS, it is relayed to the Remote Manager and written to the error log.

# 11.7. ACMSMGR DELETE TRAP

## ACMSMGR DELETE TRAP

ACMSMGR DELETE TRAP — Deletes a record from the trap table.

### Format

ACMSMGR DELETE TRAP [/qualifiers]

Command Qualifier	Default
/ENTITY=[*,entity-name]	Qualifier is required.
/NAME=[*,entity-name]	* (all)
/NODE=node-name	Translation of logical ACMS \$MGMT_SERVER_NODE
/PARAMETER=keyword	EXISTS
/USER=user-name	Translation of logical ACMS\$MGMT_USER

### Privileges Required

ACMS\$MGMT\_OPER

### Parameters

None.

### Qualifiers

/ENTITY=[\*, ACC, CP, EXC, MGR, QTI, TSC]

This required qualifier specifies the entity or entities for which a trap should be set.

`/NAME=[*, entity-name]`

This qualifier specifies particular instances of an entity. Wildcards (\*) are allowed in names.

For the MGR entity, this field should always be set to asterisk (\*).

For ACC, CP, QTI, and TSC entity types, the entity name is the process name. For the EXC entity type, the entity name is the name of the application (for example, VR\_APPL).

The default is all (\*).

`/NODE=node-name`

This qualifier specifies a fully- or partially-qualified TCP/IP host name. This name must match the current DECnet host name. IP addresses and host names (or aliases) that exceed six characters or include mixed case are not allowed.

If the `/NODE` qualifier is not specified, the ACMSMGR utility checks for the presence of the logical name `ACMS$MGMT_SERVER_NODE`. If the logical is defined, the value of the logical is used by default.

In order for the command to execute, either the `/NODE` qualifier must be provided on the command line, or the `ACMS$MGMT_SERVER_NODE` logical must be defined.

`/PARAMETER=[EVENT_SEVERITY, EXISTS]`

This parameter specifies the field that should be monitored.

- `EVENT_SEVERITY`

Internal Remote Manager events are to be monitored. The Remote Manager logs internal events in the Remote Manager log. (See Section 11.35 and Section 4.7 for discussions of the Remote Manager log.) Traps can be generated based on the severity levels of these events.

- `EXISTS`

Process existence is to be monitored. Traps are generated if the associated entity type and name either starts or stops.

`/USER=user-name`

This qualifier specifies the name of the OpenVMS account on the server node to be used for authorization. If this qualifier is specified, an explicit login must already have been completed successfully (see Section 11.10).

If the `/USER` qualifier is not specified, the ACMSMGR utility checks for the presence of the logical name `ACMS$MGMT_USER`. If the logical is defined, the value of the logical is used by default.

If the `/USER` qualifier is not specified and the `ACMS$MGMT_USER` logical is not defined, the ACMSMGR utility attempts proxy access. See Section 4.4.1.2 for a discussion of proxy access.

## Notes

When deleting trap records, the combination of entity, name and parameter must exactly match a row in the trap table.

Traps become inactive as soon as they are deleted from the Trap table.

## Examples

```
$ ACMSMGR DELETE TRAP/ENT=ACC/PARAM=EXISTS
```

This command deletes a trap from the Trap table.

## 11.8.

### ACMSMGR HELP

ACMSMGR HELP — Displays help information about the ACMS Remote Manager Client (ACMSMGR) and its commands.

#### Format

ACMSMGR HELP

#### Privileges Required

None.

#### Parameters

None.

#### Qualifiers

None.

#### Notes

Online help is available for each ACMSMGR command. Each help topic summarizes the valid syntax, abbreviations, parameters, and qualifiers for a particular command and also indicates all default and required values.

For a comprehensive list of ACMS utilities that offer online help or for further instructions on how to invoke help, see ACMS Help.

#### Examples

```
$ ACMSMGR HELP
```

This command invokes online help for the ACMSMGR utility and displays a list of available topics.

## 11.9. ACMSMGR LOGIN

### ACMSMGR LOGIN

ACMSMGR LOGIN — Logs in to a server on one or more nodes.

## Format

### ACMSMGR LOGIN [/qualifiers]

Command Qualifier	Default
/NODE=node-name	Translation of logical ACMS\$MGMT_SERVER_NODE
/PASSWORD=password	None
/USER=user-name	Translation of logical ACMS\$MGMT_USER

## Privileges Required

ACMS\$MGMT\_READ

## Parameters

None.

## Qualifiers

/NODE=node-name

This qualifier specifies a fully- or partially-qualified TCP/IP host name. This name must match the current DECnet host name. IP addresses and host names (or aliases) that exceed six characters or include mixed case are not allowed.

If the /NODE qualifier is not specified, the ACMSMGR utility checks for the presence of the logical name ACMS\$MGMT\_SERVER\_NODE. If the logical is defined, the value of the logical is used by default.

In order for the command to execute, either the /NODE qualifier must be provided on the command line, or the ACMS\$MGMT\_SERVER\_NODE logical must be defined.

/PASSWORD=password

This qualifier specifies the password of the OpenVMS account on the server node to log in as. It is sent encrypted to the server node for verification.

If the /PASSWORD parameter is not specified, the ACMSMGR will prompt the user for a password. Login will not be attempted without a password.

/USER=user-name

This qualifier specifies the name of the OpenVMS account on the server node on which to log in.

If the /USER qualifier is not specified, the ACMSMGR utility checks for the presence of the logical name ACMS\$MGMT\_USER. If the logical is defined, the value of the logical is used by default.

If the /USER qualifier is not specified and the ACMS\$MGMT\_USER logical is not defined, the ACMSMGR utility prompts the user for a user name. Login cannot be attempted without a user name.

## Notes

In order to access any remote management functions, a valid login is required if proxy access is not enabled or if proxy accounts have not been set up.

A credentials file is created for each node logged in to. Credentials files are specific for a user, process, and node. In addition, a separate credentials file is created for each combination of user name and node. Subsequent ACMSMGR commands pass the authentication information in the appropriate credentials file to the Remote Manager server, which then performs function authorization. Users determine which credentials are used either by using the /USER qualifier or by defining the ACMS\$MGMT\_USER logical.

For example, suppose user BOB on node CLIENT logs in to node SERV1 as ACMS\_ADMIN. Also, suppose user BOB on node CLIENT logs in to node SERV2 as ACMS\_USER. BOB will have two active logins (two credentials files). He can specify which one to use by either defining the logical ACMS\$MGMT\_USER, or specifying a user name using the /USER qualifier.

Logins are valid for the duration of the login\_credentials\_lifetime parameter (specified using the ACMSMGR SET PARAMETER command).

See Section 4.4 for a complete discussion of how logins are processed and how credentials files are handled.

## Examples

- `$ ACMSMGR LOGIN /NODE=SPARKS /USER=USERNAME /PASSWORD=12345678`

This command logs in user USERNAME to node SPARKS.

- `$ ACMSMGR LOGIN /NODE=SPARKS,NELSON /USER=USERNAME /PASSWORD=12345678`

This command logs in user USERNAME to nodes SPARKS and NELSON.

- `$ ACMSMGR LOGIN /USER=USERNAME`

This command logs in user USERNAME to the node specified by the logical name ACMS\$MGMT\_SERVER\_NODE. The ACMSMGR utility will prompt the user for the password.

- `$ ACMSMGR LOGIN`

This command logs in the user defined by the logical name ACMS\$MGMT\_USER to the node specified by the logical name ACMS\$MGMT\_SERVER\_NODE. If the logical name ACMS\$MGMT\_USER is not defined, the ACMSMGR utility will prompt for the user name. The ACMSMGR utility also will prompt for the password.

## 11.10. ACMSMGR LOGOUT

### ACMSMGR LOGOUT

ACMSMGR LOGOUT — Logs out a user from a server on one or more nodes.

#### Format

ACMSMGR LOGOUT [/qualifiers]

Command Qualifier	Default
/NODE=node-name	Translation of logical ACMS\$MGMT_SERVER_NODE
/USER=user-name	Translation of logical ACMS\$MGMT_USER

## Privileges Required

ACMS\$MGMT\_READ

## Parameters

None.

## Qualifiers

/NODE=node-name

This qualifier specifies a fully- or partially-qualified TCP/IP host name. This name must match the current DECnet host name. IP addresses and host names (or aliases) that exceed six characters or include mixed case are not allowed.

If the /NODE qualifier is not specified, the ACMSMGR utility checks for the presence of the logical name ACMS\$MGMT\_SERVER\_NODE. If the logical is defined, the value of the logical is used by default.

In order for the command to execute, either the /NODE qualifier must be provided on the command line, or the ACMS\$MGMT\_SERVER\_NODE logical must be defined.

/USER=user-name

This qualifier specifies the name of the OpenVMS account on the server node from which to log out.

If the /USER qualifier is not specified, the ACMSMGR utility checks for the presence of the logical name ACMS\$MGMT\_USER. If the logical is defined, the value of the logical is used by default.

If the /USER qualifier is not specified and the ACMS\$MGMT\_USER logical is not defined, the ACMSMGR utility prompts the user for a user name. Logout cannot be performed without a user name.

## Notes

Once logout is complete, subsequent ACMSMGR commands for a user, process, and node will fail authorization checks.

## Examples

- `$ ACMSMGR LOGOUT /NODE=SPARKS /USER=USERNAME`

This command logs out user USERNAME from node SPARKS.

- `$ ACMSMGR LOGOUT /NODE=SPARKS,NELSON /USER=USERNAME /PASSWORD=12345`



This command logs out user USERNAME from nodes SPARKS and NELSON.

- \$ ACMSMGR LOGOUT /USER=USERNAME

This command logs out user USERNAME from the node specified by the logical name ACMS\$MGMT\_SERVER\_NODE.

- \$ ACMSMGR LOGOUT

This command logs out the user defined by the logical name ACMS\$MGMT\_USER from the node specified by the logical name ACMS\$MGMT\_SERVER\_NODE. If the logical name ACMS\$MGMT\_USER is not defined, the ACMSMGR utility will prompt for the user name.

## 11.11. ACMSMGR REPLACE SERVER

### ACMSMGR REPLACE SERVER

ACMSMGR REPLACE SERVER — Replaces a running server in a running ACMS application.

#### Format

ACMSMGR REPLACE SERVER [/qualifiers]

Command Qualifier	Default
/APPLICATION=[*,application-name]	* (all)
/NODE=node-name	Translation of logical ACMS\$MGMT_SERVER_NODE
/SERVER=[*,server-name]	* (all)
/USER=user-name	Translation of logical ACMS\$MGMT_USER

#### Privileges Required

ACMS\$MGMT\_OPER

#### Parameters

None.

#### Qualifiers

/APPLICATION=[\*, application-name]

This qualifier specifies the name of the application. If this qualifier is not specified, the command is executed for all applications on the target node.

/NODE=node-name

This qualifier specifies a fully- or partially-qualified TCP/IP host name. This name must match the current DECnet host name. IP addresses and host names (or aliases) that exceed six characters or include mixed case are not allowed.

If the /NODE qualifier is not specified, the ACMSMGR utility checks for the presence of the logical name ACMS\$MGMT\_SERVER\_NODE. If the logical is defined, the value of the logical is used by default.

In order for the command to execute, either the /NODE qualifier must be provided on the command line, or the ACMS\$MGMT\_SERVER\_NODE logical must be defined.

/SERVER=[\*, server-name]

This qualifier specifies the name of the server. If this qualifier is not specified, the command is executed for all servers on the target node in the target application.

/USER=user-name

This qualifier specifies the name of the OpenVMS account on the server node to be used for authorization. If this qualifier is specified, an explicit login must already have been completed successfully (see Section 11.10).

If the /USER qualifier is not specified, the ACMSMGR utility checks for the presence of the logical name ACMS\$MGMT\_USER. If the logical is defined, the value of the logical is used by default.

If the /USER qualifier is not specified and the ACMS\$MGMT\_USER logical is not defined, the ACMSMGR utility attempts proxy access. See Section 4.4.1.2 for a discussion of proxy access.

## Notes

This command is equivalent to the ACMSOPER command ACMS/REPLACE SERVER. The command is executed synchronously.

## Examples

```
$ ACMSMGR REPLACE SERVER /APPL=VR_APPL/SERV=VR_READ_SERVER/NODE=SPARKS
```

This command replaces the VR\_READ\_SERVER in the VR\_APPL application on node SPARKS.

# 11.12. ACMSMGR RESET ERROR

## ACMSMGR RESET ERROR

ACMSMGR RESET ERROR — Resets (closes) the Remote Manager error log file and creates (opens) a new version. This command (and its qualifiers) is only for use with systems running ACMS Version 4.4 or higher.

## Format

ACMSMGR RESET ERROR [/qualifiers]

Command Qualifier	Default
/NODE=node-name	Translation of logical ACMS\$MGMT_SERVER_NODE
/USER=user-name	Translation of logical ACMS\$MGMT_USER

## Privileges Required

ACMS\$MGMT\_WRITE

## Parameters

None.

## Qualifiers

`/NODE=node-name`

This qualifier specifies a fully- or partially-qualified TCP/IP host name. This name must match the current DECnet host name. IP addresses and host names (or aliases) that exceed six characters or include mixed case are not allowed.

If the `/NODE` qualifier is not specified, the ACMSMGR utility checks for the presence of the logical name `ACMS$MGMT_SERVER_NODE`. If the logical is defined, the value of the logical is used by default.

In order for the command to execute, either the `/NODE` qualifier must be provided on the command line, or the `ACMS$MGMT_SERVER_NODE` logical must be defined.

`/USER=user-name`

This qualifier specifies the name of the OpenVMS account on the server node to be used for authorization. If this qualifier is specified, an explicit login must already have been completed successfully (see Section 11.10).

If the `/USER` qualifier is not specified, the ACMSMGR utility checks for the presence of the logical name `ACMS$MGMT_USER`. If the logical is defined, the value of the logical is used by default.

If the `/USER` qualifier is not specified and the `ACMS$MGMT_USER` logical is not defined, the ACMSMGR utility attempts proxy access. See Section 4.4.1.2 for a discussion of proxy access.

## Notes

This command closes the current version of the ACMSMGR error log file and opens a new version.

## Examples

```
$ ACMSMGR RESET ERROR /NODE=SPARKS /USER=USERNAME
```

This command resets the Remote Manager error log on node SPARKS.

# 11.13. ACMSMGR RESET LOG

## ACMSMGR RESET LOG

**ACMSMGR RESET LOG** — Resets (closes) the Remote Manager log file and creates (opens) a new version.

## Format

**ACMSMGR RESET LOG [/qualifiers]**

Command Qualifier	Default
/NODE=node-name	Translation of logical ACMS\$MGMT_SERVER_NODE
/USER=user-name	Translation of logical ACMS\$MGMT_USER

## Privileges Required

ACMS\$MGMT\_WRITE

## Parameters

None.

## Qualifiers

/NODE=node-name

This qualifier specifies a fully- or partially-qualified TCP/IP host name. This name must match the current DECnet host name. IP addresses and host names (or aliases) that exceed six characters or include mixed case are not allowed.

If the /NODE qualifier is not specified, the ACMSMGR utility checks for the presence of the logical name ACMS\$MGMT\_SERVER\_NODE. If the logical is defined, the value of the logical is used by default.

In order for the command to execute, either the /NODE qualifier must be provided on the command line, or the ACMS\$MGMT\_SERVER\_NODE logical must be defined.

/USER=user-name

This qualifier specifies the name of the OpenVMS account on the server node to be used for authorization. If this qualifier is specified, an explicit login must already have been completed successfully (see Section 11.10).

If the /USER qualifier is not specified, the ACMSMGR utility checks for the presence of the logical name ACMS\$MGMT\_USER. If the logical is defined, the value of the logical is used by default.

If the /USER qualifier is not specified and the ACMS\$MGMT\_USER logical is not defined, the ACMSMGR utility attempts proxy access. See Section 4.4.1.2 for a discussion of proxy access.

## Notes

This command closes the current version of the ACMSMGR log file and opens a new version.

## Examples

```
$ ACMSMGR RESET LOG /NODE=SPARKS /USER=USERNAME
```

This command resets the Remote Manager log on node SPARKS.

## 11.14. ACMSMGR SAVE FILTER

### ACMSMGR SAVE FILTER

ACMSMGR SAVE FILTER — Saves the current records in the Error Filter table to a file. This command (and its qualifiers) is only for use with systems running ACMS Version 4.4 or higher.

#### Format

ACMSMGR SAVE FILTER [/qualifiers]

Command Qualifier	Default
/FILE=file-name	Qualifier is required.
/NODE=node-name	Translation of logical ACMS\$MGMT_SERVER_NODE
/USER=user-name	Translation of logical ACMS\$MGMT_USER

#### Privileges Required

ACMS\$MGMT\_WRITE

#### Parameters

None.

#### Qualifiers

/FILE=file-name

This required qualifier specifies a full OpenVMS file specification (*node::device:[directory]file-name.ext*) that indicates where the error filter information is to be written. Partial specifications and logical names are not valid.

/NODE=node-name

This qualifier specifies a fully- or partially-qualified TCP/IP host name. This name must match the current DECnet host name. IP addresses and host names (or aliases) that exceed six characters or include mixed case are not allowed.

If the /NODE qualifier is not specified, the ACMSMGR utility checks for the presence of the logical name ACMS\$MGMT\_SERVER\_NODE. If the logical is defined, the value of the logical is used by default.

In order for the command to execute, either the /NODE qualifier must be provided on the command line, or the ACMS\$MGMT\_SERVER\_NODE logical must be defined.

/USER=user-name

This qualifier specifies the name of the OpenVMS account on the server node to be used for authorization. If this qualifier is specified, an explicit login must already have been completed successfully (see Section 11.10).

If the /USER qualifier is not specified, the ACMSMGR utility checks for the presence of the logical name ACMS\$MGMT\_USER. If the logical is defined, the value of the logical is used by default.

If the /USER qualifier is not specified and the ACMS\$MGMT\_USER logical is not defined, the ACMSMGR utility attempts proxy access. See Section 4.4.1.2 for a discussion of proxy access.

## Notes

This command provides the ability to write the current set of error filter records to an external file. The /FILE qualifier is required and must reference a valid, complete OpenVMS file specification. Logicals and partial names are not recognized.

## Examples

```
$ ACMSMGR SAVE FILTER/FILE=VLCROW::DISK1$:[SYSTEM.FILTER]ERROR_FILTER.TXT/
NODE=SPARKS
```

This command saves the error filter records for node SPARKS to the DISK1\$: [SYSTEM.FILTER]ERROR\_FILTER.TXT on node VLCROW.

# 11.15. ACMSMGR SET ACC

## ACMSMGR SET ACC

ACMSMGR SET ACC — Makes modifications to the ACMS system.

### Format

ACMSMGR SET ACC [/qualifiers]

Command Qualifier	Default
/ACC_PRIORITY=value	None
/ACC_USERNAME=user-name	None
/ACTIVE	/STORED
/ASTLM=value	None Only for use on systems running ACMS Version 4.4 or higher.
/AUDIT_STATE=keyword	None
/BIOLM=value	None. See /process-quota. Only for use on systems running ACMS Version 4.4 or higher.
/BYTLM=value	None. See /process-quota. Only for use on systems running ACMS Version 4.4 or higher.
/CHANNELCNT=value	None. See /system-parameter.

Command Qualifier	Default
	Only for use on systems running ACMS Version 4.4 or higher.  This special parameter is used by HP and is subject to change. Do not change this parameter unless HP recommends that you do so.
/DIOLM=value	None. See /process-quota.
/ENQLM=value	None. See /process-quota.
/FILLM=value	None. See /process-quota.
/GBLPAGES=value	None. See /system-parameter.
/GBLPAGFIL=value	None. See /system-parameter.
/GBLSECTIONS=value	None. See /system-parameter.
/LOG	None
/MAX_APPL=value	None
/MSS_MAXBUF=value	None
/MSS_MAXOBJ=value	None
/MSS_NET_RETRY_TIMER=value	None
/MSS_POOLSIZE=value	None
/MSS_PROCESS_POOL=value	None
/NODE=node-name	Translation of logical ACMS \$MGMT_SERVER_NODE
/NODE_NAME=node-name	None
/PGFLQUOTA=value	None. See /process-quota.  Only for use on systems running ACMS Version 4.4 or higher.
/STORED	/STORED
/TQELM=value	None. See /process-quota.
/TWS_POOLSIZE=value	None
/TWSC_POOLSIZE=value	None
/USER=user-name	Translation of logical ACMS\$MGMT_USER
/USERNAME_DEFAULT=user-name	None
/WS_POOLSIZE=value	None
/WSC_POOLSIZE=value	None
/WSDEFAULT=value	None. See /process-quota.
/WSEXTENT=value	None. See /process-quota.
/WSQUOTA=value	None. See /process-quota.

## Privileges Required

ACMS\$MGMT\_OPER

ACMS\$MGMT\_SYSUPD (for system parameters)

## Parameters

None.

## Qualifiers

`/process-quota=value`

These qualifiers correspond to and update the related process quota fields in the system user authorization (SYSUAF) record for the user specified by ACC\_USERNAME. Updated quota values apply to the next process that is created.

Because these qualifiers control the nondynamic values for the related process quotas, the /ACTIVE qualifier cannot be specified. The /STORED qualifier is the default and causes the specified values to be stored in the current SYSUAF.DAT file.

For information on using AUTHORIZE to modify process quotas, see the *OpenVMS System Manager's Manual*. For more information about the individual quotas and their values, see *OpenVMS System Management Utilities Reference Manual: A-L* or access the online help for AUTHORIZE.

`/system-parameter=value`

These qualifiers correspond to and update the related OpenVMS System Generation utility (SYSGEN) parameters. Updated parameter values apply to the next process that is created. The ACMS\$MGMT\_SYSUPD rights identifier is required to set these parameters.

Because these qualifiers control the nondynamic values for the related system parameters, the /ACTIVE qualifier cannot be specified. The /STORED qualifier is the default and causes the specified values to be stored in the current SYSGEN work area.

For information on using SYSGEN, see the *OpenVMS System Manager's Manual*. For more information about the individual parameters and their values, see *OpenVMS System Management Utilities Reference Manual: M-Z* or access the online help for SYSGEN.

`/ACC_PRIORITY=value`

This qualifier corresponds to and updates the ACMSGEN field ACC\_PRIORITY. Because this is a nondynamic ACMSGEN field, the /ACTIVE qualifier cannot be specified with this qualifier. The /STORED qualifier causes the specified value to be stored in the current ACMSGEN file.

`/ACC_USERNAME=user-name`

This qualifier corresponds to and updates the ACMSGEN field ACC\_USERNAME. Because this is a nondynamic ACMSGEN field, the /ACTIVE qualifier cannot be specified with this qualifier. The /STORED qualifier causes the specified value to be stored in the current ACMSGEN file.

`/ACTIVE`

This qualifier causes dynamic ACMSGEN field values to be updated from the current ACMSGEN file. The /ACTIVE qualifier cannot be specified on the same command with the /STORED qualifier. If neither is specified, the default is /STORED. If /ACTIVE is specified, no updates are written to the file.



`/AUDIT_STATE=[ENABLED, DISABLED]`

This qualifier is equivalent to the ACMSOPER command ACMS/SET SYSTEM/AUDIT (or /NOAUDIT if the value is DISABLED).

`/LOG`

This qualifier causes status information for the current SET transaction to be displayed to the terminal (SYSS\$OUTPUT). This qualifier is useful when setting multiple values; a separate status message is displayed for each value that is set.

`/MAX_APPL=value`

This qualifier corresponds to and updates the ACMSGEN field MAX\_APPL. Because this is a nondynamic ACMSGEN field, the /ACTIVE qualifier cannot be specified with this qualifier. The /STORED qualifier causes the specified value to be stored in the current ACMSGEN file.

`/MSS_MAXBUF=value`

This qualifier corresponds to and updates the ACMSGEN field MSS\_MAXBUF. Because this is a nondynamic ACMSGEN field, the /ACTIVE qualifier cannot be specified with this qualifier. The /STORED qualifier causes the specified value to be stored in the current ACMSGEN file.

`/MSS_MAXOBJ=value`

This qualifier corresponds to and updates the ACMSGEN field MSS\_MAXOBJ. Because this is a nondynamic ACMSGEN field, the /ACTIVE qualifier cannot be specified with this qualifier. The /STORED qualifier causes the specified value to be stored in the current ACMSGEN file.

`/MSS_NET_RETRY_TIMER=value`

This qualifier corresponds to and updates the ACMSGEN field MSS\_NET\_RETRY\_TIMER. As this is a dynamic ACMSGEN field, the /ACTIVE qualifier causes the current value to be modified for the running system. The /STORED qualifier causes the specified value to be stored in the current ACMSGEN file.

`/MSS_POOLSIZE=value`

This qualifier corresponds to and updates the ACMSGEN field MSS\_POOLSIZE. Because this is a nondynamic ACMSGEN field, the /ACTIVE qualifier cannot be specified with this qualifier. The /STORED qualifier causes the specified value to be stored in the current ACMSGEN file.

`/MSS_PROCESS_POOL=value`

This qualifier corresponds to and updates the ACMSGEN field MSS\_PROCESS\_POOL. Because this is a nondynamic ACMSGEN field, the /ACTIVE qualifier cannot be specified with this qualifier. The /STORED qualifier causes the specified value to be stored in the current ACMSGEN file.

`/NODE=node-name`

This qualifier specifies a fully- or partially-qualified TCP/IP host name. This name must match the current DECnet host name. IP addresses and host names (or aliases) that exceed six characters or include mixed case are not allowed.

If the /NODE qualifier is not specified, the ACMSMGR utility checks for the presence of the logical name ACMS\$MGMT\_SERVER\_NODE. If the logical is defined, the value of the logical is used by default.

In order for the command to execute, either the /NODE qualifier must be provided on the command line, or the ACMS\$MGMT\_SERVER\_NODE logical must be defined.

**/NODE\_NAME=node-name**

This qualifier corresponds to and updates the ACMSGEN field NODE\_NAME. Because this is a nondynamic ACMSGEN field, the /ACTIVE qualifier cannot be specified with this qualifier. The /STORED qualifier causes the specified value to be stored in the current ACMSGEN file.

**/STORED**

This qualifier causes ACMSGEN field updates to be written and saved in the current ACMSGEN file. The /STORED qualifier cannot be specified on the same command as the /ACTIVE qualifier. If neither is specified, the default is /STORED.

**/TWS\_POOLSIZE=value**

This qualifier corresponds to and updates the ACMSGEN field TWS\_POOLSIZE. Because this is a nondynamic ACMSGEN field, the /ACTIVE qualifier cannot be specified with this qualifier. The /STORED qualifier causes the specified value to be stored in the current ACMSGEN file.

**/TWSC\_POOLSIZE=value**

This qualifier corresponds to and updates the ACMSGEN field TWSC\_POOLSIZE. Because this is a nondynamic ACMSGEN field, the /ACTIVE qualifier cannot be specified with this qualifier. The /STORED qualifier causes the value specified to be stored in the current ACMSGEN file.

**/USER=user-name**

This qualifier specifies the name of the OpenVMS account on the server node to be used for authorization. If this qualifier is specified, an explicit login must already have been completed successfully (see Section 11.10).

If the /USER qualifier is not specified, the ACMSMGR utility checks for the presence of the logical name ACMS\$MGMT\_USER. If the logical is defined, the value of the logical is used by default.

If the /USER qualifier is not specified and the ACMS\$MGMT\_USER logical is not defined, the ACMSMGR utility attempts proxy access. See Section 4.4.1.2 for a discussion of proxy access.

**/USERNAME\_DEFAULT=user-name**

This qualifier corresponds to and updates the ACMSGEN field USERNAME\_DEFAULT. Because this is a dynamic ACMSGEN field, the /ACTIVE qualifier causes the current value to be modified for the running system. The /STORED qualifier causes the specified value to be stored in the current ACMSGEN file.

**/WS\_POOLSIZE=value**

This qualifier corresponds to and updates the ACMSGEN field WS\_POOLSIZE. Because this is a nondynamic ACMSGEN field, the /ACTIVE qualifier cannot be specified with this qualifier. The /STORED qualifier causes the specified value to be stored in the current ACMSGEN file.

`/WSC_POOLSIZE=value`

This qualifier corresponds to and updates the ACMSGEN field `WSC_POOLSIZE`. Because this is a nondynamic ACMSGEN field, the `/ACTIVE` qualifier cannot be specified with this qualifier. The `/STORED` qualifier causes the specified value to be stored in the current ACMSGEN file.

## Notes

This command provides the ability to remotely update either the running ACMS system or the current ACMSGEN file.

The `/ACTIVE` and `/STORED` qualifiers control how updates are posted to ACMSGEN. The `/ACTIVE` and `/STORED` qualifiers have no effect on the `/AUDIT_STATE` qualifier, which is processed independently of any ACMSGEN updates.

## Examples

- `$ ACMSMGR SET ACC /NODE=SPARKS/MSS_NET_RETRY_TIMER=250/ACTIVE`

This command modifies the ACMSGEN field `mss_net_retry_timer` on node SPARKS and updates the active system only. The change is not saved in the ACMSGEN file.

- `$ ACMSMGR SET ACC /NODE=SPARKS/MSS_NET_RETRY_TIMER=500/STORED`

This command modifies the ACMSGEN field `mss_net_retry_timer` on node SPARKS and saves the change in the ACMSGEN file. The active system is not updated.

- `$ ACMSMGR SET ACC /NODE=SPARKS/CHANNELCNT=255/STORED`

This command modifies the `CHANNELCNT` system parameter on node SPARKS and saves the change in the SYSGEN work area. The active system is not updated.

# 11.16. ACMSMGR SET AGENT

## ACMSMGR SET AGENT

ACMSMGR SET AGENT — Makes modifications to the ACMS system.

### Format

**ACMSMGR SET AGENT** [**/qualifiers**]

Command Qualifier	Default
<code>/PID=value</code>	None (Mandatory)
<code>/ASTLM=value</code>	None. See <code>/process-quota</code> .
<code>/BIOLM=value</code>	None. See <code>/process-quota</code> .
<code>/BYTLM=value</code>	None. See <code>/process-quota</code> .
<code>/DIOLM=value</code>	None. See <code>/process-quota</code> .
<code>/ENQLM=value</code>	None. See <code>/process-quota</code> .
<code>/FILLM=value</code>	None. See <code>/process-quota</code> .

/LOG	None
/PGFLQUOTA=value	None. See /process-quota.
/TQELM=value	None. See /process-quota.
/WSDEFAULT=value	None. See /process-quota.
/WSEXTENT=value	None. See /process-quota.
/WSQUOTA=value	None. See /process-quota.
/NODE=value	None
/USER=value	None

## Privileges Required

ACMS\$MGMT\_OPER

ACMS\$MGMT\_SYSUPD (for system parameters)

## Parameters

None.

## Qualifiers

/PID=pid

Specifies the Process ID of the Agent the stored values of which to modify. The /PID qualifier is Mandatory.

/process-quota=value

These qualifiers correspond to and update the related process quota fields in the system user authorization (SYSUAF) record for the user of the Agent using the supplied process PID. Updated quota values apply to the next Agent that is created.

Because these qualifiers control the nondynamic values for the related process quota fields, the /ACTIVE qualifier cannot be specified. The /STORED qualifier causes the specified values to be stored in the current SYSUAF.DAT file.

For information on using AUTHORIZE to modify process quotas, see the *OpenVMS System Manager's Manual*. For more information about the individual quotas and their values, see *OpenVMS System Management Utilities Reference Manual: A-L* or access the online help for AUTHORIZE.

/LOG=value

This qualifier causes status information for the current SET transaction to be displayed to the terminal (SYSS\$OUTPUT). This qualifier is useful when setting multiple values; a separate status message is displayed for each value that is set.

/NODE=node-name

This qualifier specifies a fully- or partially-qualified TCP/IP host name. This name must match the current DECnet host name. IP addresses and host names (or aliases) that exceed six characters or include mixed case are not allowed.

If the /NODE qualifier is not specified, the ACMSMGR utility checks for the presence of the logical name ACMS\$MGMT\_SERVER\_NODE. If the logical is defined, the value of the logical is used by default.

In order for the command to execute, either the /NODE qualifier must be provided on the command line, or the ACMS\$MGMT\_SERVER\_NODE logical must be defined.

/USER=user-name

This qualifier specifies the name of the OpenVMS account on the server node to be used for authorization. If this qualifier is specified, an explicit login must already have been completed successfully (see Section 11.10).

If the /USER qualifier is not specified, the ACMSMGR utility checks for the presence of the logical name ACMS\$MGMT\_USER. If the logical is defined, the value of the logical is used by default.

If the /USER qualifier is not specified and the ACMS\$MGMT\_USER logical is not defined, the ACMSMGR utility attempts proxy access. See Section 4.4.1.2 for a discussion of proxy access.

## Notes

This command provides the ability to remotely update the current ACMSGEN file.

The /ACTIVE and /STORED qualifiers are not used with the ACMSMGR SET AGENT command because only stored values can be modified.

## Examples

```
$ ACMSMGR SET AGENT /NODE=SPARKS /ASTLM=250 /PID=274009D6
```

This command modifies the ACMSGEN field astlm on node SPARKS for the Agent running in the process of the specified PID.

# 11.17. ACMSMGR SET COLLECTION

## ACMSMGR SET COLLECTION

ACMSMGR SET COLLECTION — Updates records in the Collection table.

### Format

ACMSMGR SET COLLECTION [/qualifiers]

Command Qualifier	Default
/CLASS=class-name	* (all)
/COLL_STATE=keyword	None
/ENTITY=[*,entity-name]	Qualifier is required.
/NAME=[*,entity-name]	* (all)
/NODE=node-name	Translation of logical ACMS\$MGMT_SERVER_NODE

Command Qualifier	Default
/STORAGE_END_TIME=[NEVER, /time]	None  Only for use on systems running ACMS Version 4.4 or higher.
/STORAGE_INTERVAL=value	None  Only for use on systems running ACMS Version 4.4 or higher.
/STORAGE_LOCATION=file-name	Translation of logical ACMS \$MGMT_SNAPSHOT
/STORAGE_BEGIN_TIME=[NOW, /time]	None  Only for use on systems running ACMS Version 4.4 or higher.
/STORAGE_STATE=keyword	None  Only for use on systems running ACMS Version 4.4 or higher.
/USER=user-name	Translation of logical ACMS\$MGMT_USER

## Privileges Required

ACMS\$MGMT\_WRITE

## Parameters

None.

## Qualifiers

/CLASS=[\*, CONFIG, ERROR, ID, POOL, RUNTIME]

This qualifier specifies the class to be enabled or disabled. The default is \* (all). See Section 5.1.1 for a description of each class type.

/COLL\_STATE=[ENABLED, DISABLED]

This qualifier specifies the state of the collection. When a SHOW entity command is issued, data for those classes that have their collection state set to ENABLED is displayed. Note that while the collection state is DISABLED, the data displayed for an entity may not be accurate. Data cannot be written to the data snapshot file when this qualifier is DISABLED, even when the storage state is ENABLED.

/ENTITY=[\*, ACC, AGENT, CP, EXC, GROUP, QTI, SERVER, TSC]

This required qualifier specifies the entity or entities for which collection should be enabled or disabled.

/NAME=[\*, entity-name]

This qualifier specifies particular instances of an entity. Wildcards (\*) are allowed in names.

For ACC, AGENT, CP, QTI, and TSC entity types, the entity name is the process name. For the EXC entity type, the entity name is the name of the application (for example, VR\_APPL).

Server and task group names can be specified as compound names made up of an application name and a server or task group name, separated by a period (for example, VR\_APPL.VR\_READ\_SERVER). Either part of server or task group names can be a wildcard (for example, \*.VR\_READ\_SERVER or VR\_APPL.\*). If only one part of a server or task group name is specified, it is assumed to be the application name, and the server or task group name is wildcarded. For example, VR\_APPL is equivalent to VR\_APPL.\*.

The default is all ( \* ), which is equivalent to \*.\* for a compound name.

`/NODE=node-name`

This qualifier specifies a fully- or partially-qualified TCP/IP host name. This name must match the current DECnet host name. IP addresses and host names (or aliases) that exceed six characters or include mixed case are not allowed.

If the `/NODE` qualifier is not specified, the ACMSMGR utility checks for the presence of the logical name `ACMS$MGMT_SERVER_NODE`. If the logical is defined, the value of the logical is used by default.

In order for the command to execute, either the `/NODE` qualifier must be provided on the command line, or the `ACMS$MGMT_SERVER_NODE` logical must be defined.

`/STORAGE_END_TIME=[NEVER,time]`

This qualifier specifies a time after which the collection data should no longer be written to the snapshot file. The format of *time* is *DD-MMM-YY:hh:mm:ss.nn*. Partial dates and times (for example, 10-OCT or 09:00) are supported. The keyword NEVER is also supported, which equates to the OpenVMS zero date of 17-NOV-1858 00:00:00.00. With a value of NEVER, collection data continues to be written to the snapshot file until the storage state is set to DISABLED.

If this qualifier is not specified, the existing value remains unchanged. This value can be modified dynamically.

`/STORAGE_INTERVAL=value`

This qualifier controls the frequency (in seconds) at which data snapshots are performed.

The storage interval value should be a multiple of the timer interval parameter (`SET PARAMETER/TIMER_INTERVAL`). The timer interval value determines the minimum elapsed time for many Remote Manager parameters, including the storage interval setting. The relationship of these values determine how often data snapshots are performed, for example:

- If the timer interval value is greater, its value is used by default. For instance, if the timer interval is 10 and the storage interval is 5, snapshots will be written at 10 second intervals.
- If the storage interval value is greater and is a multiple of the timer interval, the storage interval value is used. For example, if the timer interval is 10 and the storage interval is 30, snapshots will be written at 30 second intervals.
- If the storage interval value is greater and is not a multiple of the timer interval, the next multiple of the timer interval value is used. For example, if the timer interval is 10 and the storage interval is 15, snapshots will be written at 20 second intervals.

`/STORAGE_LOCATION=file-name`

This qualifier specifies an OpenVMS file specification to which collection data is to be written. The format of *file-name* is a valid OpenVMS pathname or logical (such as DISK\$1:[SYSTEM.SNAPSHOTS] or SYSS\$SYSTEM:SNAPSHOTS.DAT).

If the `/STORAGE_LOCATION` qualifier is not specified, the current value remains unchanged. If a directory is not provided as part of the specification, the file is written to the default directory of the account under which the Remote Manager process is running.

Multiple collections can share a single snapshot file or be stored in separate files. For continuity, VSI recommends that EXC, Server, and Task Group collection information be written to the same snapshot file.

This value can be modified dynamically.

`/STORAGE_BEGIN_TIME=time`

This qualifier specifies a time after which the collection data should be written to the snapshot file. The format of *time* is *DD-MMM-YY:hh:mm:ss.nn*. Partial dates and times (for example, 10-OCT or 09:00) are supported. The keyword NOW is also supported, which equates to the OpenVMS zero date of 17-NOV-1858 00:00:00.00. With a value of NOW, collection data is written to the snapshot file immediately, or as soon as the storage state is set to ENABLED.

If this qualifier is not specified, the current value remains unchanged. This value can be modified dynamically.

`/STORAGE_STATE=[ENABLED, DISABLED]`

This qualifier specifies the state of the data snapshots. To fully enable data snapshots, both the storage state and the collection state (`/COLL_STATE`) must be set to ENABLED. If this qualifier is not specified, the current value remains unchanged. This value can be modified dynamically.

`/USER=user-name`

This qualifier specifies the name of the OpenVMS account on the server node to be used for authorization. If this qualifier is specified, an explicit login must already have been completed successfully (see Section 11.10).

If the `/USER` qualifier is not specified, the ACMSMGR utility checks for the presence of the logical name ACMS\$MGMT\_USER. If the logical is defined, the value of the logical is used by default.

If the `/USER` qualifier is not specified and the ACMS\$MGMT\_USER logical is not defined, the ACMSMGR utility attempts proxy access. See Section 4.4.1.2 for a discussion of proxy access.

## Notes

When updating collection records, the combination of class, entity, and name must exactly match a record in the Collection table.

You cannot modify Collection table entries for the ID and CONFIG classes.

ACMS processes read the Collection table during process startup to determine which classes to begin collecting. Once the Remote Manager has been started, the ACMSMGR SHOW PROCESS command can be used to determine the class states for the currently running ACMS processes.



In order for collection data to be written to a snapshot file, the following conditions must be met:

- A qualifying entity must be running (one with an entity type and name matching fields in the Collection table).
- The collection state and storage state for that entity must be enabled.
- The current time must fall between the storage start time and storage end time.

If all these conditions are met, the Remote Manager opens the snapshot file for shared write operations. The file remains open until the storage state is set to `DISABLED` or until the snapshot period expires.

Changes to the Collection table are processed immediately, except for storage location and storage end time values. These values are applied the next time snapshot data is written. The Remote Manager signals the appropriate ACMS process as soon as it has reevaluated the Collection table following an addition. Messages are sent to the ACMS process using the ACMS Trace Monitor.

When multiple collection records apply to a given process, the records are assigned weights according to a precedence of name, then entity, then class. Within a column, wildcard entries are weighted less than nonwildcard entries. The row with the highest weight that applies to a process is used. The `ACMSMGR SHOW COLLECTION` command displays weights for each row in the table. See also Section 5.1.1 for a discussion of the Collection table and of how weights are assigned.

In contrast to typical collections, weighting for data snapshot threads does not apply. Therefore, it is possible for redundant collection data to be written to one or more snapshot files. If multiple collection records compile overlapping data, and each has their storage state set to `ENABLED`, each record writes data to the designated snapshot file.

## Examples

```
$ ACMSMGR SET COLLECTION/ENT=EXC/CLASS=RUNTIME/NAME=VR_APPL/COLL_S=DISABLED
```

This command disables run-time data collection for the `VR_APPL` application.

# 11.18. ACMSMGR SET CP

## ACMSMGR SET CP

`ACMSMGR SET CP` — Makes modifications to an ACMS system process. This command (and its qualifiers) is only for use with systems running ACMS Version 4.4 or higher.

### Format

`ACMSMGR SET CP [/qualifiers]`

Command Qualifier	Default
<code>/ASTLM=value</code>	None. See <code>/process-quota</code> .
<code>/BIOLM=value</code>	None. See <code>/process-quota</code> .
<code>/BYTLM=value</code>	None. See <code>/process-quota</code> .
<code>/DIOLM=value</code>	None. See <code>/process-quota</code> .

/ENQLM=value	None. See /process-quota.
/FILLM=value	None. See /process-quota.
/LOG	None.
/PGFLQUOTA=value	None. See /process-quota.
/TQELM=value	None. See /process-quota.
/WSDEFAULT=value	None. See /process-quota.
/WSEXTENT=value	None. See /process-quota.
/WSQUOTA=value	None. See /process-quota.

## Privileges Required

ACMS\$MGMT\_WRITE

## Parameters

None.

## Qualifiers

/process-quota=value

These qualifiers correspond to and update the related process quota fields in the system user authorization (SYSUAF) record for the user specified by CP\_USERNAME. Updated quota values apply to the next process that is created.

Because these qualifiers control the nondynamic values for the related process quota fields, the /ACTIVE qualifier cannot be specified. The /STORED qualifier causes the specified values to be stored in the current SYSUAF.DAT file.

For information on using AUTHORIZE to modify process quotas, see the *OpenVMS System Manager's Manual*. For more information about the individual quotas and their values, see *OpenVMS System Management Utilities Reference Manual: A-L* or access the online help for AUTHORIZE.

/LOG

This qualifier causes status information for the current SET transaction to be displayed to the terminal (SYSS\$OUTPUT). This qualifier is useful when setting multiple values; a separate status message is displayed for each value that is set.

## Notes

This command provides the ability to remotely update either the running ACMS system or the current ACM\$GEN file quota values for subsequent CP processes.

## Examples

```
$ ACMSMGR SET CP /ASTLM=1000 /LOG
```

This command modifies the ASTLM process quota and causes informational messages to be displayed that indicate the status of the update. The new ASTLM value will be applied to subsequent CP processes.

# 11.19. ACMSMGR SET EXC

## ACMSMGR SET EXC

ACMSMGR SET EXC — Makes modifications to running ACMS applications.

### Format

ACMSMGR SET EXC [/qualifiers]

Command Qualifier	Default
/ACTIVE	/ACTIVE
/APPLICATION=application-name	None
/ASTLM=value	None. See /process-quota. Only for use on systems running ACMS Version 4.4 or higher.
/AUDIT_STATE=keyword	None
/BIOLM=value	None. See /process-quota. Only for use on systems running ACMS Version 4.4 or higher.
/BYTLM=value	None. See /process-quota. Only for use on systems running ACMS Version 4.4 or higher.
/DIOLM=value	None. See /process-quota. Only for use on systems running ACMS Version 4.4 or higher.
/ENQLM=value	None. See /process-quota. Only for use on systems running ACMS Version 4.4 or higher.
/FILLM=value	None. See /process-quota. Only for use on systems running ACMS Version 4.4 or higher.
/LOG	None
/MAX_SERVERS=value	None
/MAX_TASKS=value	None
/NODE=node-name	Translation of logical ACMS \$MGMT_SERVER_NODE
/PGFLQUOTA=value	None. See /process-quota. Only for use on systems running ACMS Version 4.4 or higher.
/SP_MON_INTERVAL=value	None

Command Qualifier	Default
/STORED	/ACTIVE
/TQELM=value	None. See /process-quota. Only for use on systems running ACMS Version 4.4 or higher.
/TRANSACTION_TIMEOUT=value	None
/USER=user-name	Translation of logical ACMS\$MGMT_USER
/WSDEFAULT=value	None. See /process-quota. Only for use on systems running ACMS Version 4.4 or higher.
/WSEXTENT=value	None. See /process-quota. Only for use on systems running ACMS Version 4.4 or higher.
/WSQUOTA=value	None. See /process-quota. Only for use on systems running ACMS Version 4.4 or higher.

## Privileges Required

ACMS\$MGMT\_OPER

## Parameters

None.

## Qualifiers

/process-quota=value

These qualifiers correspond to and update the related process quota fields in the system user authorization (SYSUAF) record for the user specified by SHOW EXC/ID. Updated quota values apply to the next process that is created.

Because these qualifiers control the nondynamic values for the related process quota fields, the /ACTIVE qualifier cannot be specified. The /STORED qualifier causes the specified values to be stored in the current SYSUAF.DAT file.

For information on using AUTHORIZE to modify process quotas, see the *OpenVMS System Manager's Manual*. For more information about the individual quotas and their values, see *OpenVMS System Management Utilities Reference Manual: A-L* or access the online help for AUTHORIZE.

/ACTIVE

This qualifier causes dynamic ACMSGEN field values to be updated from the current ACMSGEN file. The /ACTIVE qualifier cannot be specified on the same command with the /STORED qualifier. If neither is specified, the default is /ACTIVE for all values except for process quotas (which default to /STORED). If /ACTIVE is specified, no updates are written to the file.

`/APPLICATION=application-name`

The name of the application to be modified. The command ACMSMGR SET EXC requires the /APPL qualifier for any values that are stored values. If the /APPL qualifier is missing, the error NOAPPLQUAL will be returned.

A different error, NOSUCHAPPL, will be returned if the application you are attempting to modify is not active.

`/AUDIT_STATE=[ENABLED, DISABLED]`

This qualifier is equivalent to the ACMSOPER command ACMS/MODIFY APPLICATION /APPL=AUDIT (or /APPL=NOAUDIT if the value is DISABLED).

`/LOG`

This qualifier causes status information for the current SET transaction to be displayed to the terminal (SYSS\$OUTPUT). This qualifier is useful when setting multiple values; a separate status message is displayed for each value that is set.

`/MAX_SERVERS=value`

This qualifier updates the MAX\_SERVERS limit in the running application. Updates are lost when the application is restarted.

`/MAX_TASKS=value`

This qualifier updates the MAX\_TASKS limit in the running application. Updates are lost when the application is restarted.

`/NODE=node-name`

This qualifier specifies a fully- or partially-qualified TCP/IP host name. This name must match the current DECnet host name. IP addresses and host names (or aliases) that exceed six characters or include mixed case are not allowed.

If the /NODE qualifier is not specified, the ACMSMGR utility checks for the presence of the logical name ACMS\$MGMT\_SERVER\_NODE. If the logical is defined, the value of the logical is used by default.

In order for the command to execute, either the /NODE qualifier must be provided on the command line, or the ACMS\$MGMT\_SERVER\_NODE logical must be defined.

`/SP_MON_INTERVAL=value`

This qualifier updates the SP\_MON\_INTERVAL field in the running application. Updates are lost when the application is restarted.

`/STORED`

This qualifier causes ACMSGEN field updates to be written and saved in the current ACMSGEN file. The /STORED qualifier cannot be specified on the same command as the /ACTIVE qualifier. If neither is specified, the default is /ACTIVE for all values except for process quotas (which default to /STORED).

`/TRANSACTION_TIME=value`

This qualifier updates the TRANSACTION\_TIMEOUT default value in the running application. Updates are lost when the application is restarted.

`/USER=user-name`

This qualifier specifies the name of the OpenVMS account on the server node to be used for authorization. If this qualifier is specified, an explicit login must already have been completed successfully (see Section 11.10).

If the `/USER` qualifier is not specified, the ACMSMGR utility checks for the presence of the logical name `ACMS$MGMT_USER`. If the logical is defined, the value of the logical is used by default.

If the `/USER` qualifier is not specified and the `ACMS$MGMT_USER` logical is not defined, the ACMSMGR utility attempts proxy access. See Section 4.4.1.2 for a discussion of proxy access.

## Notes

This command is equivalent to the ACMSOPER command `ACMS/MOD APPLICATION`. Any changes made to the running system are lost when the application is restarted.

## Examples

```
$ ACMSMGR SET EXC/APPL=VR_APPL/SP_MON_INTERVAL=10/MAX_TASKS=50
```

This command modifies the running application `VR_APPL`.

# 11.20. ACMSMGR SET INTERFACE

## ACMSMGR SET INTERFACE

ACMSMGR SET INTERFACE — Allows Remote Manager interfaces to be started or stopped.

### Format

ACMSMGR SET INTERFACE `[/qualifiers]`

Command Qualifier	Default
<code>/INTERFACE=[RPC,SNMP]</code>	Qualifier is required.
<code>/NODE=node-name</code>	Translation of logical <code>ACMS\$MGMT_SERVER_NODE</code>
<code>/STATE=[ENABLED,DISABLED]</code>	DISABLED
<code>/USER=user-name</code>	Translation of logical <code>ACMS\$MGMT_USER</code>

### Privileges Required

`ACMS$MGMT_WRITE`

### Parameters

None.

### Qualifiers

`/INTERFACE=[RPC, SNMP]`

This required qualifier specifies which interface to modify. Only SNMP is supported.

`/NODE=node-name`

This qualifier specifies a fully- or partially-qualified TCP/IP host name. This name must match the current DECnet host name. IP addresses and host names (or aliases) that exceed six characters or include mixed case are not allowed.

If the `/NODE` qualifier is not specified, the ACMSMGR utility checks for the presence of the logical name `ACMS$MGMT_SERVER_NODE`. If the logical is defined, the value of the logical is used by default.

In order for the command to execute, either the `/NODE` qualifier must be provided on the command line, or the `ACMS$MGMT_SERVER_NODE` logical must be defined.

`/STATE=[ENABLED, DISABLED]`

This qualifier specifies the operation to perform. If the value is `ENABLED`, the interface will be started (if it is not already running). If the value is `DISABLED`, the interface will be stopped (if it is not already stopped).

`/USER=user-name`

This qualifier specifies the name of the OpenVMS account on the server node to be used for authorization. If this qualifier is specified, an explicit login must already have been completed successfully (see Section 11.10).

If the `/USER` qualifier is not specified, the ACMSMGR utility checks for the presence of the logical name `ACMS$MGMT_USER`. If the logical is defined, the value of the logical is used by default.

If the `/USER` qualifier is not specified and the `ACMS$MGMT_USER` logical is not defined, the ACMSMGR utility attempts proxy access. See Section 4.4.1.2 for a discussion of proxy access.

## Notes

This command allows interfaces to be stopped or started. However, an interface cannot disable itself. Since the ACMSMGR utility uses the RPC interface, it cannot be used to disable the RPC interface. To disable the RPC interface, either use the `ACMSCFG` utility and restart the Remote Manager, or use the SNMP interface.

The SNMP interface can be both enabled and disabled using this command. It may take several seconds for this command to complete if the SNMP interface is in a non-interruptible state when the command is issued.

## Examples

```
$ ACMSMGR SET INTERFACE/INTERFACE=SNMP/STATE=DISABLED
```

```
ACMS Remote Management Option -- Command line utility
Call to modify interface on server sparks was executed
%ACMSMGMT-S-SUCCESS, Operation completed
```

This command stops the SNMP interface on the node specified by the logical name `ACMS$MGMT_SERVER_NODE`. Authorization is either performed for the user specified by the logical `ACMS$MGMT_USER`, or is based on an ACMS proxy on the target node if the logical is not defined.

# 11.21. ACMSMGR SET PARAMETER

## ACMSMGR SET PARAMETER

ACMSMGR SET PARAMETER — Allows Remote Manager parameters to be modified.

### Format

ACMSMGR SET PARAMETER [/qualifiers]

Command Qualifier	Default
/DCL_AUDIT_LEVEL=value	See /parameter.
/DCL_MGR_PRIORITY=value	See /parameter.
/DCL_STACKSIZE=value	See /parameter.
/ERROR_INTERVAL=value	See /parameter.  Only for use on systems running ACMS Version 4.4 or higher.
/EVENT_LOG_PRIORITY=value	See /parameter.
/LOG_STACKSIZE=value	See /parameter.
/LOGIN_CREDS_LIFETIME=value	See /parameter.
/MAX_LOGINS=value	See /parameter.
/MAX_RPC_RETURN_RECS=value	See /parameter.
/MGR_AUDIT_LEVEL=value	See /parameter.
/MSG_PROC_AUDIT_LEVEL=value	See /parameter.
/MSG_PROC_PRIORITY=value	See /parameter.
/MSG_PROC_STACKSIZE=value	See /parameter.
/MSS_COLL_INTERVAL=value	See /parameter.
/NODE=node-name	Translation of logical ACMS \$MGMT_SERVER_NODE
/PROC_MON_AUDIT_LEVEL=value	See /parameter.
/PROC_MON_INTERVAL=value	See /parameter.
/PROC_MON_PRIORITY=value	See /parameter.
/PROC_MON_STACKSIZE=value	See /parameter.
/PROXY_CREDS_LIFETIME=value	See /parameter.
/RPC_AUDIT_LEVEL=value	See /parameter.
/RPC_PRIORITY=value	See /parameter.
/RPC_STACKSIZE=value	See /parameter.
/SECURITY_AUDIT_LEVEL=value	See /parameter.
/SNAP_AUDIT_LEVEL=value	See /parameter.  Only for use on systems running ACMS Version 4.4 or higher.



<b>Command Qualifier</b>	<b>Default</b>
/SNAP_PRIORITY=value	See /parameter.  Only for use on systems running ACMS Version 4.4 or higher.
/SNAP_STACKSIZE=value	See /parameter.  Only for use on systems running ACMS Version 4.4 or higher.
/SNMP_AGENT_TIME_OUT=value	See /parameter.
/SNMP_ARE_YOU_THERE=value	See /parameter.
/SNMP_AUDIT_LEVEL=value	See /parameter.
/SNMP_PRIORITY=value	See /parameter.
/SNMP_SEL_TIME_OUT=value	See /parameter.
/SNMP_STACKSIZE=value	See /parameter.
/TCP_ENABLED	See /parameter.  Only for use on systems running ACMS Version 4.4 or higher.
/TIMER_AUDIT_LEVEL=value	See /parameter.
/TIMER_INTERVAL=value	See /parameter.
/TIMER_PRIORITY=value	See /parameter.
/TIMER_STACKSIZE=value	See /parameter.
/TOTAL_ENTITY_SLOTS=value	See /parameter.
/TRACE_MSG_WAIT_TIME=value	See /parameter.
/TRACE_START_WAIT_TIME=value	See /parameter.
/TRAP_AUDIT_LEVEL=value	See /parameter.
/TRAP_PRIORITY=value	See /parameter.
/TRAP_STACKSIZE=value	See /parameter.
/UDP_ENABLED	See /parameter.  Only for use on systems running ACMS Version 4.4 or higher.
/USER=user-name	Translation of logical ACMS\$MGMT_USER
/VMS_COLL_INTERVAL=value	See /parameter.  Only for use on systems running ACMS Version 4.4 or higher.
/WKSP_COLL_INTERVAL=value	See /parameter.

## Privileges Required

ACMS\$MGMT\_WRITE

## Parameters

None.

## Qualifiers

/parameter=value

All qualifiers except `NODE` and `USER` correspond directly to fields in the Parameter table. See Section 9.10.1 for a description of each field. For a listing of the current default, minimum, and maximum values, use the `SHOW PARAMETER` command.

/NODE=node-name

This qualifier specifies a fully- or partially-qualified TCP/IP host name. This name must match the current DECnet host name. IP addresses and host names (or aliases) that exceed six characters or include mixed case are not allowed.

If the `/NODE` qualifier is not specified, the ACMSMGR utility checks for the presence of the logical name `ACMS$MGMT_SERVER_NODE`. If the logical is defined, the value of the logical is used by default.

In order for the command to execute, either the `/NODE` qualifier must be provided on the command line, or the `ACMS$MGMT_SERVER_NODE` logical must be defined.

/USER=user-name

This qualifier specifies the name of the OpenVMS account on the server node to be used for authorization. If this qualifier is specified, an explicit login must already have been completed successfully (see Section 11.10).

If the `/USER` qualifier is not specified, the ACMSMGR utility checks for the presence of the logical name `ACMS$MGMT_USER`. If the logical is defined, the value of the logical is used by default.

If the `/USER` qualifier is not specified and the `ACMS$MGMT_USER` logical is not defined, the ACMSMGR utility attempts proxy access. See Section 4.4.1.2 for a discussion of proxy access.

## Notes

Some parameter changes take effect immediately; others take effect only when the Remote Manager is restarted, and only if they are written to the `ACMSCFG` file (using the `ACMSCFG SET PARAMETER` command). Table 9–9 shows which parameters are dynamic and which are not.

For parameters that are not dynamic, you must restart the appropriate facility for the change to take effect. For example, to modify the `SNMP_SELECT_TIME_OUT` parameter, you must stop and restart the SNMP interface.

The ACMS Remote Manager allows an authorized user to make changes to the VMS parameter file (via `SYSGEN`), ACMS parameter file (via `ACMSGEN`), user quotas (via `AUTHORIZE`), ACMS Remote Manager parameters (via `ACMSMGR SET PARAM`) and to a running ACMS system (via `ACMSOPR` commands).

Some values are checked for minimums, like negative numbers and zero. ACMS Remote Manager parameters are checked for limits but `Authorize`, `ACMSGEN` and `SYSGEN` values are not. Use the

same caution with the ACMS Remote Manager as you would with SYSGEN and AUTHORIZE and verify any changes you make.

## Examples

```
$ ACMSMGR SET PARAMETER /MGR_AUDIT_LEVEL=E /NODE=SPARKS /USER=USERNAME
```

```
ACMS Remote Management Option -- Command line utility
Call to modify parameters on server sparks was executed
%ACMSMGMT-S-SUCCESS, Operation completed
```

This command modifies the dynamic parameter MGR\_AUDIT\_LEVEL on node SPARKS and specifies that authorization be performed for user USERNAME.

## 11.22. ACMSMGR SET QTI

### ACMSMGR SET QTI

ACMSMGR SET QTI — Makes modifications related to the Queued Task Initiator (QTI).

#### Format

ACMSMGR SET QTI [/qualifiers]

Command Qualifier	Default
/ACTIVE	/STORED
/ASTLM=value	None. See /process-quota. Only for use on systems running ACMS Version 4.4 or higher.
/BIOLM=value	None. See /process-quota. Only for use on systems running ACMS Version 4.4 or higher.
/BYTLM=value	None. See /process-quota. Only for use on systems running ACMS Version 4.4 or higher.
/DIOLM=value	None. See /process-quota. Only for use on systems running ACMS Version 4.4 or higher.
/ENQLM=value	None. See /process-quota. Only for use on systems running ACMS Version 4.4 or higher.
/FILLM=value	None. See /process-quota. Only for use on systems running ACMS Version 4.4 or higher.
/LOG	None

Command Qualifier	Default
/NODE=node-name	Translation of logical ACMS \$MGMT_SERVER_NODE
/PGFLQUOTA=value	None. See /process-quota.  Only for use on systems running ACMS Version 4.4 or higher.
/POLLING_TIMER=value	None
/QTI_PRIORITY=value	None
/QTI_USERNAME=user-name	None
/RETRY_TIMER	None
/STORED	/STORED
/SUB_TIMEOUT	None
/TQELM=value	None. See /process-quota.  Only for use on systems running ACMS Version 4.4 or higher.
/USER=user-name	Translation of logical ACMS\$MGMT_USER
/WSDEFAULT=value	None. See /process-quota.  Only for use on systems running ACMS Version 4.4 or higher.
/WSEXTENT=value	None. See /process-quota.  Only for use on systems running ACMS Version 4.4 or higher.
/WSQUOTA=value	None. See /process-quota.  Only for use on systems running ACMS Version 4.4 or higher.

## Privileges Required

ACMS\$MGMT\_OPER

## Parameters

None.

## Qualifiers

/process-quota=value

These qualifiers correspond to and update the related process quota fields in the system user authorization (SYSUAF) record for the user specified by QTI\_USERNAME. Updated quota values apply to the next process that is created.

Because these qualifiers control the nondynamic values for the related process quota fields, the /ACTIVE qualifier cannot be specified. The /STORED qualifier causes the specified values to be stored in the current SYSUAF.DAT file.

For information on using AUTHORIZE to modify process quotas, see the *OpenVMS System Manager's Manual*. For more information about the individual quotas and their values, see *OpenVMS System Management Utilities Reference Manual: A-L* or access the online help for AUTHORIZE.

#### `/ACTIVE`

This qualifier causes dynamic ACMSGEN field values to be updated from the current ACMSGEN file. The `/ACTIVE` qualifier cannot be specified on the same command with the `/STORED` qualifier. If neither is specified, the default is `/STORED`. If `/ACTIVE` is specified, no updates are written to the file.

#### `/LOG`

This qualifier causes status information for the current SET transaction to be displayed to the terminal (`SYSS$OUTPUT`). This qualifier is useful when setting multiple values; a separate status message is displayed for each value that is set.

#### `/NODE=node-name`

This qualifier specifies a fully- or partially-qualified TCP/IP host name. This name must match the current DECnet host name. IP addresses and host names (or aliases) that exceed six characters or include mixed case are not allowed.

If the `/NODE` qualifier is not specified, the ACMSMGR utility checks for the presence of the logical name `ACMS$MGMT_SERVER_NODE`. If the logical is defined, the value of the logical is used by default.

In order for the command to execute, either the `/NODE` qualifier must be provided on the command line, or the `ACMS$MGMT_SERVER_NODE` logical must be defined.

#### `/POLLING_TIMER=node-name`

This qualifier corresponds to and updates the ACMSGEN field `QTI_POLLING_TIMER`. Because this is a dynamic ACMSGEN field, the `/ACTIVE` qualifier causes the current value to be modified for the running system. The `/STORED` qualifier causes the specified value to be stored in the current ACMSGEN file.

#### `/QTI_PRIORITY=value`

This qualifier corresponds to and updates the ACMSGEN field `QTI_PRIORITY`. Because this is a nondynamic ACMSGEN field, the `/ACTIVE` qualifier cannot be specified with this qualifier. The `/STORED` qualifier causes the specified value to be stored in the current ACMSGEN file.

#### `/QTI_USERNAME=user-name`

This qualifier corresponds to and updates the ACMSGEN field `QTI_USERNAME`. Because this is a nondynamic ACMSGEN field, the `/ACTIVE` qualifier cannot be specified with this qualifier. The `/STORED` qualifier causes the specified value to be stored in the current ACMSGEN file.

#### `/RETRY_TIMER=value`

This qualifier corresponds to and updates the ACMSGEN field `QTI_RETRY_TIMER`. Because this is a dynamic ACMSGEN field, the `/ACTIVE` qualifier causes the current value to be modified for the running system. The `/STORED` qualifier causes the specified value to be stored in the current ACMSGEN file.

**/STORED**

This qualifier causes ACMSGEN field updates to be written and saved in the current ACMSGEN file. The /STORED qualifier cannot be specified on the same command as the /ACTIVE qualifier. If neither is specified, the default is /STORED.

**/SUB\_TIMEOUT=value**

This qualifier corresponds to and updates the ACMSGEN field QTI\_SUB\_TIMEOUT. Because this is a dynamic ACMSGEN field, the /ACTIVE qualifier causes the current value to be modified for the running system. The /STORED qualifier causes the specified value to be stored in the current ACMSGEN file.

**/USER=user-name**

This qualifier specifies the name of the OpenVMS account on the server node to be used for authorization. If this qualifier is specified, an explicit login must already have been completed successfully (see Section 11.10).

If the /USER qualifier is not specified, the ACMSMGR utility checks for the presence of the logical name ACMS\$MGMT\_USER. If the logical is defined, the value of the logical is used by default.

If the /USER qualifier is not specified and the ACMS\$MGMT\_USER logical is not defined, the ACMSMGR utility attempts proxy access. See Section 4.4.1.2 for a discussion of proxy access.

**Notes**

This command allows you to remotely update either the running ACMS system or the current ACMSGEN file.

The /ACTIVE and /STORED qualifiers control how updates are posted to ACMSGEN. The /ACTIVE and /STORED qualifiers have no effect on the /AUDIT\_STATE qualifier, which is processed independently of any ACMSGEN updates.

**Examples**

- `$ ACMSMGR SET QTI /NODE=SPARKS/SUB_TIMEOUT=5000/ACTIVE`

This command modifies the ACMSGEN field qti\_sub\_timeout on node SPARKS and updates the active system only. The change is not saved in the ACMSGEN file.

- `$ ACMSMGR SET QTI /NODE=SPARKS/SUB_TIMEOUT=5000/STORED`

This command modifies the ACMSGEN field qti\_sub\_timeout on node SPARKS and saves the change in the ACMSGEN file. The active system is not updated.

## 11.23. ACMSMGR SET SERVER

### ACMSMGR SET SERVER

ACMSMGR SET SERVER — Makes modifications to servers running in ACMS applications.

## Format

### ACMSMGR SET SERVER [/qualifiers]

Command Qualifier	Default
/APPLICATION=[*,application-name]	* (all)
/CREATION_DELAY=value	None
/CREATION_INTERVAL=value	None
/DELETION_DELAY=value	None
/DELETION_INTERVAL=value	None
/LOG	None
/MAX_INSTANCE=value	None
/MIN_INSTANCE=value	None
/NODE=node-name	Translation of logical ACMS \$MGMT_SERVER_NODE
/SERVER=[*,server_name]	* (all)
/SP_DUMP_FLAG=	
####[ENABLED,DISABLED]	None
/USER=user-name	Translation of logical ACMS\$MGMT_USER

## Privileges Required

ACMS\$MGMT\_OPER

## Parameters

None.

## Qualifiers

/APPLICATION=application-name

The name of the application to be modified. If this qualifier is not specified, modifications are applied to all applications.

/CREATION\_DELAY=value

This qualifier updates the CREATION\_DELAY for the specified server in the running application. Updates are lost when the application is restarted.

/CREATION\_INTERVAL=value

This qualifier updates the CREATION\_INTERVAL for the specified server in the running application. Updates are lost when the application is restarted.

/DELETION\_DELAY=value

This qualifier updates the DELETION\_DELAY for the specified server in the running application. Updates are lost when the application is restarted.

`/DELETION_INTERVAL=value`

This qualifier updates the `DELETION_INTERVAL` for the specified server in the running application. Updates are lost when the application is restarted.

`/LOG`

This qualifier causes status information for the current SET transaction to be displayed to the terminal (`SYSS$OUTPUT`). This qualifier is useful when setting multiple values; a separate status message is displayed for each value that is set.

`/MAX_INSTANCE=value`

This qualifier updates the `MAX_INSTANCE` limit for the specified server in the running application. Updates are lost when the application is restarted.

`/MIN_INSTANCE=value`

This qualifier updates the `MIN_INSTANCE` limit for the specified server in the running application. Updates are lost when the application is restarted.

`/NODE=node-name`

This qualifier specifies a fully- or partially-qualified TCP/IP host name. This name must match the current DECnet host name. IP addresses and host names (or aliases) that exceed six characters or include mixed case are not allowed.

If the `/NODE` qualifier is not specified, the ACMSMGR utility checks for the presence of the logical name `ACMS$MGMT_SERVER_NODE`. If the logical is defined, the value of the logical is used by default.

In order for the command to execute, either the `/NODE` qualifier must be provided on the command line, or the `ACMS$MGMT_SERVER_NODE` logical must be defined.

`/SERVER=server-names`

This qualifier specifies the name of the server to be modified. If this qualifier is not specified, all servers in the application are modified.

`/SP_DUMP_FLAG=value`

This qualifier updates the `SP_DUMP_FLAG` for the specified server in the running application. Updates are lost when the application is restarted.

`/USER=user-name`

This qualifier specifies the name of the OpenVMS account on the server node to be used for authorization. If this qualifier is specified, an explicit login must already have been completed successfully (see Section 11.10).

If the `/USER` qualifier is not specified, the ACMSMGR utility checks for the presence of the logical name `ACMS$MGMT_USER`. If the logical is defined, the value of the logical is used by default.

If the `/USER` qualifier is not specified and the `ACMS$MGMT_USER` logical is not defined, the ACMSMGR utility attempts proxy access. See Section 4.4.1.2 for a discussion of proxy access.



## Notes

This command is equivalent to the ACMSOPER command ACMS/MOD APPLICATION/SERVER. Any changes made to the running system are lost when the application is restarted.

## Examples

```
$ ACMSMGR SET SERVER/APPL=VR_APPL/SERVER=VR_READ_SERVER/
SP_DUMP_FLAG=ENABLED
```

This command modifies the SP\_DUMP\_FLAG field for the server VR\_READ\_SERVER running in the VR\_APPL application.

# 11.24. ACMSMGR SET TRAP

## ACMSMGR SET TRAP

ACMSMGR SET TRAP — Updates records in the Trap table.

### Format

ACMSMGR SET TRAP [/qualifiers]

Command Qualifier	Default
/ENTITY=[*,entity-name]	Qualifier is required.
/NAME=[*,entity-name]	*(all)
/NODE=node-name	Translation of logical ACMS\$MGMT_SERVER_NODE
/PARAMETER=keyword	EXISTS
/SEVERITY=[I,W,E,F]	E
/TRAP_MIN=value	-1
/TRAP_MAX=value	-1
/USER=user-name	Translation of logical ACMS\$MGMT_USER

### Privileges Required

ACMS\$MGMT\_OPER

### Parameters

None.

### Qualifiers

/ENTITY=[\*, ACC, CP, EXC, MGR, QTI, TSC]

This required qualifier specifies the entity or entities for which a trap should be set.

/NAME=[\*, entity-name]

This qualifier specifies particular instances of an entity. Wildcards (\*) are allowed in names.

For the MGR entity, this field should always be set to asterisk (\*).

For ACC, CP, QTI, and TSC entity types, the entity name is the process name. For the EXC entity type, the entity name is the name of the application (for example, VR\_APPL).

The default is all (\*).

`/NODE=node-name`

This qualifier specifies a fully- or partially-qualified TCP/IP host name. This name must match the current DECnet host name. IP addresses and host names (or aliases) that exceed six characters or include mixed case are not allowed.

If the `/NODE` qualifier is not specified, the ACMSMGR utility checks for the presence of the logical name `ACMS$MGMT_SERVER_NODE`. If the logical is defined, the value of the logical is used by default.

In order for the command to execute, either the `/NODE` qualifier must be provided on the command line, or the `ACMS$MGMT_SERVER_NODE` logical must be defined.

`/PARAMETER=[EVENT_SEVERITY, EXISTS]`

This parameter specifies the field that should be monitored.

- `EVENT_SEVERITY`

Internal Remote Manager events are to be monitored. The Remote Manager logs internal events in the Remote Manager log. (See Section 11.35 and Section 4.7 for discussions of the Remote Manager log.) Traps can be generated based on the severity levels of these events.

- `EXISTS`

Process existence is to be monitored. Traps are generated if the associated entity type and name either starts or stops.

`/SEVERITY=[I, W, E, F]`

This qualifier specifies the severity to be associated with the trap. Severity codes are embedded in the trap message and must be parsed by the trap receiver. Severities are informational (I), warning (W), error (E), or fatal (F).

`/TRAP_MIN=value`

This qualifier specifies the minimum allowable value for the parameter being monitored. A trap is generated if the parameter value is less than the minimum. See Section 9.14.2 for a list of valid values.

`/TRAP_MAX=value`

This qualifier specifies the maximum allowable value for the parameter being monitored. A trap is generated if the parameter value is greater than the maximum. See Section 9.14.2 for a list of valid values.

`/USER=user-name`

This qualifier specifies the name of the OpenVMS account on the server node to be used for authorization. If this qualifier is specified, an explicit login must already have been completed successfully (see Section 11.10).

If the /USER qualifier is not specified, the ACMSMGR utility checks for the presence of the logical name ACMS\$MGMT\_USER. If the logical is defined, the value of the logical is used by default.

If the /USER qualifier is not specified and the ACMS\$MGMT\_USER logical is not defined, the ACMSMGR utility attempts proxy access. See Section 4.4.1.2 for a discussion of proxy access.

## Notes

When updating trap records, the combination of entity, name, and parameter must exactly match a record in the Trap table.

Changes become active as soon as they are added to the Trap table.

See Section 9.14.2 for a discussion about setting appropriate trap minimums and maximums. See Section 9.14.3 for a description of the trap message generated.

## Examples

```
$ ACMSMGR SET TRAP /ENT=QTI/PARAM=EXISTS/MAX=0
```

This command causes an SNMP trap to be generated whenever the QTI process is started if the SNMP interface is running.

# 11.25. ACMSMGR SET TSC

## ACMSMGR SET TSC

ACMSMGR SET TSC — Makes modifications to the ACMS terminal subsystem.

### Format

ACMSMGR SET TSC [/qualifiers]

Command Qualifier	Default
/ACTIVE	/STORED
/ASTLM=value	None. See /process-quota. Only for use on systems running ACMS Version 4.4 or higher.
/BIOLM=value	None. See /process-quota. Only for use on systems running ACMS Version 4.4 or higher.
/BYTLM=value	None. See /process-quota. Only for use on systems running ACMS Version 4.4 or higher.
/CP_PRIORITY=value	None
/CP_SLOTS=value	None

<b>Command Qualifier</b>	<b>Default</b>
/CP_USERNAME=user-name	None
/DIOLM=value	None. See /process-quota. Only for use on systems running ACMS Version 4.4 or higher.
/ENQLM=value	None. See /process-quota. Only for use on systems running ACMS Version 4.4 or higher.
/FILLM=value	None. See /process-quota. Only for use on systems running ACMS Version 4.4 or higher.
/LOG	None
/MAX_LOGINS=value	None
/MAX_TTS_CP=value	None
/MIN_CPIS=value	None
/NODE=node-name	Translation of logical ACMS \$MGMT_SERVER_NODE
/PERM_CPS=value	None
/PGFLQUOTA=value	None. See /process-quota. Only for use on systems running ACMS Version 4.4 or higher.
/STORED	/STORED
/TQELM=value	None. See /process-quota. Only for use on systems running ACMS Version 4.4 or higher.
/TSC_PRIORITY=value	None
/TSC_USERNAME=user-name	None
/USER=user-name	Translation of logical ACMS\$MGMT_USER
/WSDEFAULT=value	None. See /process-quota. Only for use on systems running ACMS Version 4.4 or higher.
/WSEXTENT=value	None. See /process-quota. Only for use on systems running ACMS Version 4.4 or higher.
/WSQUOTA=value	None. See /process-quota. Only for use on systems running ACMS Version 4.4 or higher.

## Privileges Required

ACMS\$MGMT\_OPER

## Parameters

None.

## Qualifiers

`/process-quota=value`

These qualifiers correspond to and update the related process quota fields in the system user authorization (SYSUAF) record for the user specified by `/TSC_USERNAME`. Updated quota values apply to the next process that is created.

Because these qualifiers control the nondynamic values for the related process quota fields, the `/ACTIVE` qualifier cannot be specified. The `/STORED` qualifier is the default and causes the specified values to be stored in the current SYSUAF.DAT file.

For information on using `AUTHORIZE` to modify process quotas, see the *OpenVMS System Manager's Manual*. For more information about the individual quotas and their values, see *OpenVMS System Management Utilities Reference Manual: A-L* or access the online help for `AUTHORIZE`.

`/ACTIVE`

This qualifier causes dynamic ACMSGEN field values to be updated from the current ACMSGEN file. The `/ACTIVE` qualifier cannot be specified on the same command with the `/STORED` qualifier. If neither is specified, the default is `/STORED`. If `/ACTIVE` is specified, no updates are written to the file.

`/CP_PRIORITY=value`

This qualifier corresponds to and updates the ACMSGEN field `CP_PRIORITY`. Because this is a nondynamic ACMSGEN field, the `/ACTIVE` qualifier cannot be specified with this qualifier. The `/STORED` qualifier causes the specified value to be stored in the current ACMSGEN file.

`/CP_SLOTS=value`

This qualifier corresponds to and updates the ACMSGEN field `CP_SLOTS`. Because this is a nondynamic ACMSGEN field, the `/ACTIVE` qualifier cannot be specified with this qualifier. The `/STORED` qualifier causes the specified value to be stored in the current ACMSGEN file.

`/CP_USERNAME=user-name`

This qualifier corresponds to and updates the ACMSGEN field `CP_USERNAME`. Because this is a nondynamic ACMSGEN field, the `/ACTIVE` qualifier cannot be specified with this qualifier. The `/STORED` qualifier causes the specified value to be stored in the current ACMSGEN file.

`/LOG`

This qualifier causes status information for the current SET transaction to be displayed to the terminal (SYSS\$OUTPUT). This qualifier is useful when setting multiple values; a separate status message is displayed for each value that is set.

`/MAX_LOGINS=value`

This qualifier corresponds to and updates the ACMSGEN field `MSS_MAX_LOGINS`. As this is a dynamic ACMSGEN field, the `/ACTIVE` qualifier causes the current value to be modified for

the running system. The /STORED qualifier causes the value specified to be stored in the current ACMSGEN file.

`/MAX_TTS_CP=value`

This qualifier corresponds to and updates the ACMSGEN field MAX\_TTS\_CP. Because this is a dynamic ACMSGEN field, the /ACTIVE qualifier causes the current value to be modified for the running system. The /STORED qualifier causes the specified value to be stored in the current ACMSGEN file.

`/MIN_CPIS=value`

This qualifier corresponds to and updates the ACMSGEN field MIN\_CPIS. Because this is a dynamic ACMSGEN field, the /ACTIVE qualifier causes the current value to be modified for the running system. The /STORED qualifier causes the specified value to be stored in the current ACMSGEN file.

`/NODE=node-name`

This qualifier specifies a fully- or partially-qualified TCP/IP host name. This name must match the current DECnet host name. IP addresses and host names (or aliases) that exceed six characters or include mixed case are not allowed.

If the /NODE qualifier is not specified, the ACMSMGR utility checks for the presence of the logical name ACMS\$MGMT\_SERVER\_NODE. If the logical is defined, the value of the logical is used by default.

In order for the command to execute, either the /NODE qualifier must be provided on the command line, or the ACMS\$MGMT\_SERVER\_NODE logical must be defined.

`/PERM_CPS=value`

This qualifier corresponds to and updates the ACMSGEN field PERM\_CPS. Because this is a dynamic ACMSGEN field, the /ACTIVE qualifier causes the current value to be modified for the running system. The /STORED qualifier causes the specified value to be stored in the current ACMSGEN file.

`/STORED`

This qualifier causes ACMSGEN field updates to be written and saved in the current ACMSGEN file. The /STORED qualifier cannot be specified on the same command as the /ACTIVE qualifier. If neither is specified, the default is /STORED.

`/TSC_PRIORITY=value`

This qualifier corresponds to and updates the ACMSGEN field TSC\_PRIORITY. Because this is a nondynamic ACMSGEN field, the /ACTIVE qualifier cannot be specified with this qualifier. The /STORED qualifier causes the specified value to be stored in the current ACMSGEN file.

`/TSC_USERNAME=user-name`

This qualifier corresponds to and updates the ACMSGEN field TSC\_USERNAME. Because this is a nondynamic ACMSGEN field, the /ACTIVE qualifier cannot be specified with this qualifier. The /STORED qualifier causes the specified value to be stored in the current ACMSGEN file.

`/USER=user-name`

This qualifier specifies the name of the OpenVMS account on the server node to be used for authorization. If this qualifier is specified, an explicit login must already have been completed successfully (see Section 11.10).

If the `/USER` qualifier is not specified, the ACMSMGR utility checks for the presence of the logical name `ACMS$MGMT_USER`. If the logical is defined, the value of the logical is used by default.

If the `/USER` qualifier is not specified and the `ACMS$MGMT_USER` logical is not defined, the ACMSMGR utility attempts proxy access. See Section 4.4.1.2 for a discussion of proxy access.

## Notes

This command provides the ability to remotely update either the running ACMS system or the current ACMSGEN file.

The `/ACTIVE` and `/STORED` qualifiers control how updates are posted to ACMSGEN.

## Examples

- `$ ACMSMGR SET TSC /NODE=SPARKS/MAX_LOGINS=500/ACTIVE`

This command modifies the ACMSGEN field `max_logins` on node SPARKS and updates the active system only. The change is not saved in the ACMSGEN file.

- `$ ACMSMGR SET TSC /NODE=SPARKS/MAX_LOGINS=500/STORED`

This command modifies the ACMSGEN field `max_logins` on node SPARKS and saves the change in the ACMSGEN file. The active system is not updated.

# 11.26. ACMSMGR SHOW ACC

## ACMSMGR SHOW ACC

ACMSMGR SHOW ACC — Displays information about an ACC on one or more remote nodes.

### Format

ACMSMGR SHOW ACC [/qualifiers]

Command Qualifier	Default
<code>/[BRIEF,FULL]</code>	<code>/FULL</code> if the <code>CLASS=* (all)</code> . <code>/BRIEF</code> , otherwise.
<code>/CLASS=keyword</code>	*
<code>/ACTIVE</code>	See Notes.
<code>/[BRIEF,FULL]</code>	<code>/FULL</code> if no class qualifier ( <code>/CONFIG</code> , <code>/ID</code> , <code>/POOL</code> , or <code>/RUNTIME</code> ) is specified. Otherwise, <code>/BRIEF</code> .
<code>/[CONFIG,ID,POOL,RUNTIME]</code>	* (all)
<code>/INTERVAL=interval</code>	Command is executed once.

Command Qualifier	Default
/NODE=node-name	Translation of logical ACMS \$MGMT_SERVER_NODE
/OUT=file-name	None
/STORED	See Notes.
/USER=user-name	Translation of logical ACMS\$MGMT_USER

## Privileges Required

ACMS\$MGMT\_READ

## Parameters

None.

## Qualifiers

/ACTIVE

When specified with the /BRIEF qualifier, this qualifier causes active ACMSGEN field values to be displayed. /ACTIVE is effective only when used with the /CONFIG qualifier. If /BRIEF is not specified, or if /FULL is specified, this qualifier has no effect (both active and stored values are displayed).

/[BRIEF,FULL]

This qualifier causes either summary (/BRIEF) or detailed (/FULL) information to be displayed. If no class qualifier (/CONFIG, /ERROR, /ID, /POOL, or /RUNTIME) is specified, this qualifier is ignored and all details are displayed (equivalent to /FULL). Note that OpenVMS process quota and SYSGEN parameter information is only shown when /FULL is specified.

/[CONFIG,ERROR,ID,POOL,RUNTIME]

This qualifier causes data for only the specified class to be displayed. The default is to display information for all classes.

/INTERVAL=interval

This qualifier causes the command to be reissued automatically at a specified interval (in seconds). Use either Ctrl/C or Ctrl/Y to interrupt the command. If this qualifier is not specified, the command is executed only once.

/NODE=node-name

This qualifier specifies a fully- or partially-qualified TCP/IP host name. This name must match the current DECnet host name. IP addresses and host names (or aliases) that exceed six characters or include mixed case are not allowed.

If the /NODE qualifier is not specified, the ACMSMGR utility checks for the presence of the logical name ACMS\$MGMT\_SERVER\_NODE. If the logical is defined, the value of the logical is used by default.

In order for the command to execute, either the /NODE qualifier must be provided on the command line, or the ACMS\$MGMT\_SERVER\_NODE logical must be defined.



**/OUT=file-name**

This qualifier causes output to be written to the specified file. If this qualifier is not specified, output is displayed to the terminal (SYSS\$OUTPUT).

**/STORED**

When specified with the **/BRIEF** qualifier, this qualifier causes field values from the ACMSGEN file (not those active in memory) to be displayed. The **/STORED** qualifier is effective only when used with the **/CONFIG** qualifier. If **/BRIEF** is not specified, or if **/FULL** is specified, this qualifier has no effect (both active and stored values are displayed).

**/USER=user-name**

This qualifier specifies the name of the OpenVMS account on the server node to be used for authorization. If this qualifier is specified, an explicit login must already have been completed successfully (see Section 11.10).

If the **/USER** qualifier is not specified, the ACMSMGR utility checks for the presence of the logical name ACMS\$MGMT\_USER. If the logical is defined, the value of the logical is used by default.

If the **/USER** qualifier is not specified and the ACMS\$MGMT\_USER logical is not defined, the ACMSMGR utility attempts proxy access. See Section 4.4.1.2 for a discussion of proxy access.

## Notes

This command displays information about the ACC on the target node. The **/BRIEF** and **/FULL** qualifiers control the format of information to be displayed. To display OpenVMS process quota and SYSGEN parameter information, use the **/FULL** qualifier.

See Section 9.2 for a discussion of each field displayed.

Note that some information may not be current, depending on whether the class to which the data belongs has been enabled for the ACC. The Config Class field indicates whether or not information is being collected for that class.

## Examples

```
1. $ ACMSMGR SHOW ACC /CONFIG /NODE=GOCROW,VLCROW
ACMS Remote Management - Command line utility  ACMS V4.3-0  ACC Table
Display                                         Time: 25-AUG-1999 13:59:06.99
      A Collect  Audit  Max  Mss  Mss Proc  Mss  Mss  WS
      TWS
      Node S  State  State  Appl Max Obj  Pool  Poolsize Maxbuf
      Poolsize Poolsize
      -----
      gocrow A enabled enabled 10  1006  512  4096  1544  256
      1440
      vlcrow A enabled enabled 10  1006  512  2048  1544  256
      1440
```

This command displays ACC configuration information from nodes GOCROW and VLCROW. Authorization is performed for the user specified by the logical name ACMS\$MGMT\_USER,

or by proxy if the logical is not defined. Only summary configuration information is displayed because neither the /BRIEF nor /FULL qualifier was supplied.

2. \$ ACMSMGR SHOW ACC /NODE=VLCROW /USER=JONES

ACMS Remote Management - Command line utility

ACMS V4.3-0 ACC Table Display

Time: 25-AUG-1999

13:59:04.38

=====  
Node IDENTIFICATION

-----

```

vlcrow Id Class Collection State      enabled
       Version                       V4.3-0
       Process Name                   ACMS01ACC001000
       PID                             37C0024F
       User Name                       LT$ACC_V31
       Start Time                      24-AUG-1999 14:49:15.76
       End Time                        (null)
Node   CONFIGURATION                 Active           Stored

```

-----

```

vlcrow Config Class Collection State  enabled
       System Auditing State          enabled
       ACC Running State              started
       ACC Username                   LT$ACC_V31      LT$ACC_V31
       ACC Base Priority               4              4
       Max Applications                10             10
       MSS Max Objects                 1006           1006
       MSS Maxbuf (bytes)              1544           1544
       MSS Poolsize (pagelets)         2048           2048
       MSS Process Pool (pagelets)     512            512
       MSS Net Retry Timer (D) (seconds) 10             10
       Username Default (D)            LTU_ACMSDEF   LTU_ACMSDEF
       Node Name (ACMSGEN) (DECnet node) VLCROW        VLCROW
       WS Poolsize (pagelets)          256            256
       WSC Poolsize (pagelets)         128            128
       TWS Poolsize (pagelets)         1440           1440
       TWSC Poolsize (pagelets)        169            169
Node   RUNTIME

```

-----

```

vlcrow Runtime Class Collection State  enabled
       DECnet Object                   started
       Gauges                          Current Max   Limit  Max
Time

```

-----

```

       Users: Total                     4           85
(null)
       Users: Local                     4           20
(null)
       Users: Remote                    0           0
(null)
       Applications                     1           1       20       24-
AUG-1999 14:49:49.19

```

Number of application starts 6

```

Process Quotas          Current      Max          Limit
Max Time
-----
Working Set Size       6544         6544         300000
18-APR-2001 14:49:15.76
  AST Limit            5 ( 0%)      5 ( 0%)      500
18-APR-2001 14:49:15.76
  Byte Limit           1792 ( 0%)   3648 ( 0%)   1775409
18-APR-2001 14:49:15.76
  Direct I/O Limit     0 ( 0%)      1 ( 0%)      15000
18-APR-2001 14:49:15.76
  Buffered I/O Limit   2 ( 0%)      3 ( 0%)      10000
18-APR-2001 14:49:15.76
  Enqueue Limit        2 ( 0%)      2 ( 0%)      2000
18-APR-2001 14:49:15.76
  File Limit           3 ( 0%)      3 ( 0%)      1001
18-APR-2001 14:49:15.76
  Page File Quota     7056 ( 1%)   7056 ( 1%)   500000
18-APR-2001 14:49:15.76
  Timer Queue Limit   4 ( 0%)      4 ( 0%)      500
18-APR-2001 14:49:15.76
  Channel Count       29 ( 11%)    31 ( 12%)    256
18-APR-2001 14:49:15.76
Node      POOL
-----
-----
vlcrow   Pool Class Collection State  enabled
Objects  Current      Max      Time
-----
MSS Objects  252         432     25-AUG-1999
13:59:03.86
Process Pool          Pct      Time
-----
Pool Size             262144
Current Free (bytes)  255312   (97%)
Minimum Free (bytes)  255056   (97%)  24-AUG-1999
15:00:17.30
Largest Current Free Block (bytes) 65536
Minimum Largest Free Block (bytes) 65536          25-AUG-1999
13:59:03.25
Allocation Failures      0
Garbage Collections      0
Shared Pool              Pct      Time
-----
Pool Size             1048576
Current Free (bytes)   973176   (92%)
Minimum Free (bytes)   948480   (90%)  24-AUG-1999
16:s22:58.01
Largest Current Free Block (bytes) 65536
Minimum Largest Free Block (bytes) 65536          25-AUG-1999
13:59:03.25
Allocation Failures      0

```

This command displays all ACC management information from node VLCROW. Authorization is performed for user JONES. Since no class qualifiers (/ID, /CONFIG, /RUNTIME, /POOL) were specified, information is returned for all classes by default.

## 11.27. ACMSMGR SHOW AGENT

### ACMSMGR SHOW AGENT

ACMSMGR SHOW AGENT — Displays Collection table data for one or more Agents.

#### Format

ACMSMGR SHOW AGENT [/qualifiers]

Command Qualifier	Default
/ACTIVE	active (CONFIG class brief display)
/ALL	Inactive data not displayed
/BRIEF	default when a class is specified
/[CONFIG,ERROR,ID,POOL,RUNTIME]	all are shown when no class is specified
/FULL	full when no class is specified
/INTERVAL=value	none
/OUT=[filespec,logical_name]	sys\$output
/PROCESS_NAME=proc_name	*
/STORED	active
/NODE=value	none
/USER=value	none

#### Parameters

None.

#### Qualifiers

/ACTIVE

When specified with the /BRIEF qualifier, this qualifier causes active ACMSGEN field values to be displayed. /ACTIVE is effective only when used with the /CONFIG qualifier. If /BRIEF is not specified, or if /FULL is specified, this qualifier has no effect (both active and stored values are displayed).

/ALL

This qualifier displays all available application data, even data for applications that may no longer be running. When applications are stopped, the table row they were occupying is marked for reuse. If the row has not been reused, the data remains available for display. This qualifier allows that data to be displayed. Inactive rows are flagged with an asterisk ( \* ) in the output.

To inhibit the display of old data, do not specify this qualifier. By default, only data for currently running processes is displayed.

**/[BRIEF,FULL]**

This qualifier causes either summary (/BRIEF) or detailed (/FULL) information to be displayed. If no class qualifier (/CONFIG, /ERROR, /ID, /POOL, or /RUNTIME) is specified, this qualifier is ignored and all details are displayed (equivalent to /FULL). Available OpenVMS process quota and SYSGEN parameter information is only displayed when /FULL is specified.

**/[CONFIG,ERROR,ID,POOL,RUNTIME]**

This qualifier causes data for only the specified class to be displayed. If this qualifier is omitted, the default is to display information for all classes.

**/INTERVAL=interval**

This qualifier causes the command to be reissued automatically at a specified interval (in seconds). Use either Ctrl/C or Ctrl/Y to interrupt the command. If this qualifier is not specified, the command is executed only once.

**/OUT=file-name**

This qualifier causes output to be written to the specified file. If this qualifier is not specified, output is displayed to the terminal (SYS\$OUTPUT).

**/PROCESS\_NAME=process-name**

This qualifier causes data for only the specified process to be displayed. If this qualifier is omitted, the default is to display information for all Agent processes.

**/STORED**

When specified with the /BRIEF qualifier, this qualifier causes field values from the ACMSGEN file (not those active in memory) to be displayed. The /STORED qualifier is effective only when used with the /CONFIG qualifier. If /BRIEF is not specified, or if /FULL is specified, this qualifier has no effect (both active and stored values are displayed).

**/NODE=node-name**

This qualifier specifies a fully- or partially-qualified TCP/IP host name. This name must match the current DECnet host name. IP addresses and host names (or aliases) that exceed six characters or include mixed case are not allowed.

If the /NODE qualifier is not specified, the ACMSMGR utility checks for the presence of the logical name ACMS\$MGMT\_SERVER\_NODE. If the logical is defined, the value of the logical is used by default.

In order for the command to execute, either the /NODE qualifier must be provided on the command line, or the ACMS\$MGMT\_SERVER\_NODE logical must be defined.

**/USER=user-name**

This qualifier specifies the name of the OpenVMS account on the server node to be used for authorization. If this qualifier is specified, an explicit login must already have been completed successfully (see Section 11.10).

If the /USER qualifier is not specified, the ACMSMGR utility checks for the presence of the logical name ACMS\$MGMT\_USER. If the logical is defined, the value of the logical is used by default.

If the /USER qualifier is not specified and the ACMS\$MGMT\_USER logical is not defined, the ACMSMGR utility attempts proxy access. See Section 4.4.1.2 for a discussion of proxy access.

## Examples

```
$ ACMSMGR SHOW AGENT
```

```
ACMS Remote Management -- Command line utility
```

```
ACMS RM Client V5.0 Agent Table Display Time: 9-FEB-2005 10:00:15.32
```

```
=====
```

```
Node IDENTIFICATION
```

```
-----
```

```
OHMARY ID Class Collection State enabled
        Process Name _FTA37:
        PID 00014D60
        User Name HALL
        Start Time 9-FEB-2005 09:58:47.12
        End Time (null)
```

```
Node CONFIGURATION Active Stored
```

```
-----
```

```
OHMARY Config Class Collection State enabled
        Working Set Default 65536 80000
        Working Set Extent 262144 90000
        Working Set Quota 65536 65535
        AST Limit 1024 1024
        Byte Limit 347184 350000
        Direct I/O Limit 500 500
        Buffered I/O Limit 500 500
        Enqueue Limit 16776959 32767
        File Limit 5000 5000
        Page File Quota 1000000 1000000
        Timer Queue Limit 150 150
```

```
Node RUNTIME
```

```
-----
```

```
OHMARY Runtime Class Collection State enabled
        Agent Running State started
        DECnet Object stopped
```

```
Terminals/Tasks/User Defined Current Max Max Time
```

```
-----
```

```
Attached Terminals 0 0 (null)
Active Task Calls 0 1 9-FEB-2005
```

```
09:58:50.6
```

```
Total Tasks Executed 258
User1 Time (null)
User2 Time (null)
User3 Time (null)
User1 Data 0
User2 Data 0
User3 Data 0
User4 Data 0
User5 Data 0
User6 Data 0
```

TDMS	Current	Max	Max Time
Active TDMS	0	0	(null)
Active TDMS Menu Requests	0	0	(null)
Active TDMS Read Messages	0	0	(null)
Active TDMS Write Messages	0	0	(null)
Active TDMS Cancels	0	0	(null)
Total TDMS Requests	0		
Total TDMS Menu Requests	0		
Total TDMS Read Messages	0		
Total TDMS Write Messages	0		
Total TDMS Cancels	0		

DECforms	Current	Max	Max Time
Active DECforms	0	0	(null)
Active DECforms Menu Requests	0	0	(null)
Active DECforms Enables	0	0	(null)
Active DECforms Disables	0	0	(null)
Active DECforms Cancel	0	0	(null)
Active DECforms Send Requests	0	0	(null)
Active DECforms Receive Requests	0	0	(null)
Active DECforms Transceive Reqsts	0	0	(null)
Total DECforms Requests	0		
Total DECforms Menu Requests	0		
Total DECforms Cancel Requests	0		
Total DECforms Send Requests	0		
Total DECforms Receive Requests	0		
Total DECforms Transceive Reqsts	0		
Total DECforms Enables	0		
Total DECforms Disables	0		

Process Quotas	Current	Max	Limit	Max Time
Working Set Size	65536	65536	262144	9-FEB-2005
AST Limit	11 (1%)	11(1%)	1024	9-FEB-2005
Byte Limit	9024(2%)	9024(2%)	347184	9-FEB-2005
Direct I/O Limit	0 (0%)	0(0%)	500	9-FEB-2005
Buffered I/O Limit	2 (0%)	2(0%)	500	9-FEB-2005
Enqueue Limit	1 (0%)	1(0%)	16776959	9-FEB-2005
File Limit	5 (0%)	5(0%)	5000	9-FEB-2005
Page File Quota	25904(2%)	25904(2%)	1000000	9-FEB-2005
Timer Queue Limit	5 (3%)	5 (3%)	150	9-FEB-2005
Channel Count	29	29		9-FEB-2005

Node POOL

```

-----
OHMARY Pool Class Collection State      enabled
        MSS Process Pool                Pct      Time
-----
        Pool Size (bytes)                7680000
        Current Free (bytes)            7669200 (99%)
        Minimum Free (bytes)            7669200 (99%)      9-FEB-2005
10:00:07.13
        Largest Current Free Block (bytes) 65536
        Minimum Largest Free Block (bytes) 65536      9-FEB-2005
10:00:07.13
        Allocation Failures 0
        Garbage Collections 0

Node      ERROR
-----
OHMARY Error Class Collection State      enabled
        Error Count                      0
        Last Error Message                0
        Time of Last Error                 (null)

```

This command displays the contents of the Collection table for all Agents that are running.

## 11.28. ACMSMGR SHOW COLLECTION

### ACMSMGR SHOW COLLECTION

ACMSMGR SHOW COLLECTION — Displays Collection table data from one or more remote nodes.

#### Format

ACMSMGR SHOW COLLECTION [/qualifiers]

Command Qualifier	Default
/[BRIEF,FULL]	/BRIEF
/INTERVAL=interval	Command is executed once.
/NODE=node-name	Translation of logical ACMS \$MGMT_SERVER_NODE
/OUT=file-name	None
/USER=user-name	Translation of logical ACMS\$MGMT_USER

#### Privileges Required

ACMS\$MGMT\_READ

#### Parameters

None.



## Qualifiers

`/[BRIEF,FULL]`

This qualifier causes either summary (`/BRIEF`) or detailed (`/FULL`) information to be displayed.

Note that storage start and end times for data snapshots are only visible when `/FULL` is provided. When not specified, the resulting summary display may contain truncated values for some of the longer fields (such as, entity name and storage location).

`/INTERVAL=interval`

This qualifier causes the command to be reissued automatically at a specified interval (in seconds). Use either `Ctrl/C` or `Ctrl/Y` to interrupt the command. If this qualifier is not specified, the command is executed only once.

`/NODE=node-name`

This qualifier specifies a fully- or partially-qualified TCP/IP host name. This name must match the current DECnet host name. IP addresses and host names (or aliases) that exceed six characters or include mixed case are not allowed.

If the `/NODE` qualifier is not specified, the ACMSMGR utility checks for the presence of the logical name `ACMS$MGMT_SERVER_NODE`. If the logical is defined, the value of the logical is used by default.

In order for the command to execute, either the `/NODE` qualifier must be provided on the command line, or the `ACMS$MGMT_SERVER_NODE` logical must be defined.

`/OUT=file-name`

This qualifier causes output to be written to the specified file. If this qualifier is not specified, output is displayed to the terminal (`SY$OUTPUT`).

`/USER=user-name`

This qualifier specifies the name of the OpenVMS account on the server node to be used for authorization. If this qualifier is specified, an explicit login must already have been completed successfully (see Section 11.10).

If the `/USER` qualifier is not specified, the ACMSMGR utility checks for the presence of the logical name `ACMS$MGMT_USER`. If the logical is defined, the value of the logical is used by default.

If the `/USER` qualifier is not specified and the `ACMS$MGMT_USER` logical is not defined, the ACMSMGR utility attempts proxy access. See Section 4.4.1.2 for a discussion of proxy access.

## Notes

This command displays data-collection configuration information on the target node.

See Section 9.6 for a discussion of each field displayed. See Section 5.1 for a discussion of collections.

## Examples

```
$ ACMSMGR SHOW COLL/NODE=VLCROW
```

```
ACMS Remote Management - Command line utility
ACMS V5.0 Entity/Collection table Display      Time: 18-APR-2001
13:59:11.31
```

Storage Node	Wt	Entity Type	Entity Name	Collect Class	Collect State	Storage Location	Storage State
Interval							
-----							
vlcrow	2	*	*	id	enabled	acms\$mgmt_snapshot	enabled
3600							
vlcrow	2	*	*	config	enabled	acms\$mgmt_snapshot	disabled
3600							
vlcrow	2	*	*	runtime	enabled	acms\$mgmt_snapshot	disabled
10							
vlcrow	2	*	*	pool	enabled	acms\$mgmt_snapshot	disabled
10							
vlcrow	2	*	*	error	enabled	acms\$mgmt_snapshot	disabled
10							

This command displays the contents of the Collection table on node VLCROW, where all collections have been enabled for all entities. Authorization is performed for the user specified by the logical ACMS\$MGMT\_USER, or by proxy if the logical is not defined. Data snapshots for the ID class have been enabled and are set to occur every 5 minutes (3600 seconds). The data files are stored in the file specified by the logical ACMS\$MGMT\_SNAPSHOT.

## 11.29. ACMSMGR SHOW CP

### ACMSMGR SHOW CP

ACMSMGR SHOW CP

#### Format

Command Qualifier	Default
/ACTIVE	See Notes.
/ALL	Current data only
/[BRIEF,FULL]	/FULL if no class qualifier (/ID, /POOL, or /RUNTIME )
	is specified. Otherwise, /BRIEF.
/[class-name]	* (all)
/INTERVAL=interval	Command is executed once.
/NODE=node-name	Translation of logical ACMS\$MGMT_SERVER_NODE
/OUT=file-name	None
/PROCESS_NAME=process-name	* (all )
/STORED	See Notes.

Command Qualifier	Default
/USER=user-name	Translation of logical ACMS\$MGMT_USER

## Privileges Required

ACMS\$MGMT\_READ

## Parameters

None.

## Qualifiers

/ACTIVE

When specified with the /BRIEF qualifier, this qualifier causes active ACMSGEN field values to be displayed. /ACTIVE is effective only when used with the /CONFIG qualifier. If /BRIEF is not specified, or if /FULL is specified, this qualifier has no effect (both active and stored values are displayed).

/ALL

This qualifier displays all available application data, even data for applications that are no longer running. When applications are stopped, the CP table row they were occupying is marked for reuse. If the row has not been reused, the data remains available for display. This qualifier allows that data to be displayed. Inactive rows are flagged with an asterisk ( \* ) in the output.

To inhibit the display of old data, do not specify this qualifier. By default, only data for currently running processes is displayed.

[/BRIEF,FULL]

This qualifier causes either summary (/BRIEF) or detailed (/FULL) information to be displayed. If no class qualifier (/CONFIG, /ERROR, /ID, /POOL, or /RUNTIME) is specified, this qualifier is ignored and all details are displayed (equivalent to /FULL). Available OpenVMS process quota and SYSGEN parameter information is only displayed when /FULL is specified.

[/CONFIG, ERROR, ID, POOL, RUNTIME]

This qualifier causes data for only the specified class to be displayed. If this qualifier is omitted, the default is to display information for all classes.

/INTERVAL=interval

This qualifier causes the command to be reissued automatically at a specified interval (in seconds). Use either Ctrl/C or Ctrl/Y to interrupt the command. If this qualifier is not specified, the command is executed only once.

/NODE=node-name

This qualifier specifies a fully- or partially-qualified TCP/IP host name. This name must match the current DECnet host name. IP addresses and host names (or aliases) that exceed six characters or include mixed case are not allowed.

If the /NODE qualifier is not specified, the ACMSMGR utility checks for the presence of the logical name ACMS\$MGMT\_SERVER\_NODE. If the logical is defined, the value of the logical is used by default.

In order for the command to execute, either the /NODE qualifier must be provided on the command line, or the ACMS\$MGMT\_SERVER\_NODE logical must be defined.

/OUT=file-name

This qualifier causes output to be written to the specified file. If this qualifier is not specified, output is displayed to the terminal (SYS\$OUTPUT).

/PROCESS\_NAME=process-name

This qualifier causes data for only the specified process to be displayed. If this qualifier is omitted, the default is to display information for all CP processes.

/STORED

When specified with the /BRIEF qualifier, this qualifier causes field values from the ACMSGEN file (not those active in memory) to be displayed. The /STORED qualifier is effective only when used with the /CONFIG qualifier. If /BRIEF is not specified, or if /FULL is specified, this qualifier has no effect (both active and stored values are displayed).

/USER=user-name

This qualifier specifies the name of the OpenVMS account on the server node to be used for authorization. If this qualifier is specified, an explicit login must already have been completed successfully (see Section 11.10).

If the /USER qualifier is not specified, the ACMSMGR utility checks for the presence of the logical name ACMS\$MGMT\_USER. If the logical is defined, the value of the logical is used by default.

If the /USER qualifier is not specified and the ACMS\$MGMT\_USER logical is not defined, the ACMSMGR utility attempts proxy access. See Section 4.4.1.2 for a discussion of proxy access.

## Notes

This command displays information about ACMS command processes (CPs) on the target node. The /BRIEF and /FULL qualifiers control the format of information to be displayed.

See Section 9.5 for a discussion of each field displayed.

Note that some information may not be current, depending on whether the class to which the data belongs has been enabled for the CP. The Collect State field indicates whether or not information is being collected for that class.

## Examples

```
$ ACMSMGR SHOW CP/RUNTIME/NODE=VLCROW
ACMS Remote Management -- Command line utility
ACMS V5.0 CP Table Display                               Time: 18-APR-2001 13:59:13.39
                                     Active  Active  Total  Total  Total
```

Runtime Dataset	Process Class	Process Name	Attached Terms	Task Calls	DECforms Requests	TDMS Requests	Task Calls
Node	Class	Name	Terms	Calls	Requests	Requests	Calls
-----							
vlcrow	enabled	ACMS01CP001000	0	0	0	0	20 0
vlcrow	enabled	ACMS01CP002000	1	1	0	0	20 0
vlcrow	enabled	ACMS01CP003000	0	0	0	0	20 0
vlcrow	enabled	ACMS01CP004000	1	1	0	0	20 0

This command displays summary RUNTIME class information for CPs on node VLCROW. Authorization is performed for the user specified by the logical name ACMS\$MGMT\_USER, or by proxy if the logical is not defined.

## 11.30. ACMSMGR SHOW ERROR

### ACMSMGR SHOW ERROR

ACMSMGR SHOW ERROR — Displays the errors recorded in the Remote Manager error log file. This command (and its qualifiers) is only for use with systems running ACMS Version 4.4 or higher.

#### Format

ACMSMGR SHOW ERROR [/qualifiers]

Command Qualifier	Default
/BEFORE=time	End of file
/BRIEF	Brief
/FILENAME=file-name	Translation of logical ACMS \$MGMT_ERR_LOG
/FULL	Brief
/INTERVAL=interval	Command is executed once.
/LOCAL	Remote
/NODE=node-name	Translation of logical ACMS \$MGMT_SERVER_NODE
/OUT=file-name	None
/SEVERITY=[I,W,E,F]	All
/SINCE=time	Beginning of file
/USER=user-name	Translation of logical ACMS\$MGMT_USER

#### Privileges Required

ACMS\$MGMT\_READ

#### Parameters

None.

## Qualifiers

### /BEFORE=time

This qualifier causes only those error log entries with a timestamp less than or equal to the *time* specified by time to be returned and displayed. The format of *time* is *DD-MMM-YY:HH:MM:SS.nn*. Partial dates and times (for example, 10-OCT or 09:00) are supported. If this qualifier is not specified, the search ends when the end of the audit file is reached.

### /BRIEF

The /BRIEF and /FULL qualifiers control the amount of information shown for any errors. ACMSMGR SHOW ERROR defaults to the /BRIEF display.

### /FILENAME=file-name

This qualifier allows log records to be displayed from a file other than the current error log file. Specify a fully- or partially-qualified file specification.

### /FULL

The /BRIEF and /FULL qualifiers control the amount of information shown for any errors. ACMSMGR SHOW ERROR defaults to the /BRIEF display.

### /INTERVAL=interval

This qualifier causes the command to be reissued automatically at a specified interval (in seconds). Use either Ctrl/C or Ctrl/Y to interrupt the command. If this qualifier is not specified, the command is executed only once.

### /LOCAL

This qualifier causes the ACMSMGR to open and read the error log on the local node directly. You can use this qualifier if the Remote Manager process is not started. The /LOCAL qualifier overrides the /NODE qualifier and the ACMS\$MGMT\_SERVER\_NODE logical.

### /NODE=node-name

This qualifier specifies a fully- or partially-qualified TCP/IP host name. This name must match the current DECnet host name. IP addresses and host names (or aliases) that exceed six characters or include mixed case are not allowed.

If the /NODE qualifier is not specified, the ACMSMGR utility checks for the presence of the logical name ACMS\$MGMT\_SERVER\_NODE. If the logical is defined, the value of the logical is used by default.

In order for the command to execute, either the /NODE qualifier must be provided on the command line, or the ACMS\$MGMT\_SERVER\_NODE logical must be defined.

### /OUT=file-name

This qualifier causes output to be written to the specified file. If this qualifier is not specified, output is displayed to the terminal (SYSS\$OUTPUT).

`/SEVERITY=[I, W, E, F]`

This qualifier causes only error log entries with matching severities to be displayed. Valid severities are informational (I), warning (W), error (E), and fatal (F). If this qualifier is not specified, all severities are returned.

`/SINCE=time`

This qualifier causes only error log entries with a timestamp greater than or equal to the time specified by *time* to be returned and displayed. The format of *time* is *DD-MMM-YY:HH:MM:SS.nn*. Partial dates and times (for example, 10- OCT or 09:00) are supported. If this qualifier is not specified, the search begins at the beginning of the audit file.

`/USER=user-name`

This qualifier specifies the name of the OpenVMS account on the server node to be used for authorization. If this qualifier is specified, an explicit login must already have been completed successfully (see Section 11.10).

If the `/USER` qualifier is not specified, the ACMSMGR utility checks for the presence of the logical name `ACMS$MGMT_USER`. If the logical is defined, the value of the logical is used by default.

If the `/USER` qualifier is not specified and the `ACMS$MGMT_USER` logical is not defined, the ACMSMGR utility attempts proxy access. See Section 4.4.1.2 for a discussion of proxy access.

## Notes

This command displays Remote Manager error log information. The format of the error log entries displayed is:

```
node time: severity: error-text
```

In this format:

- *node* is the node from which the information was obtained.
- *time* is the time the error was logged.
- *severity* is the severity of the error.
- *error-text* is the details of the error.

## Examples

```
$ ACMSMGR SHOW ERROR /NODE=VLCROW
ACMS Remote Management -- Command line utility

ACMS V5.0 Log Display Time: 18-APR-2001 13:59:13.39
Node Message
vlcrow : 17-APR-2001 10:40:41.04 : %ACMSACC-I-EVENT, Event
                                         : -ACMSACC-E-ERRSTARTA, Error occurred
starting application
                                         : -ACMSEXC-ENO_
TDB, Error opening TDB file !AS for task group !AS
vlcrow : 16-APR-2001 14:26:01.34 : %ACMSMSS-E-ERRNETCRE, Error creating
DECnet object
```

: -ACMSMSS-ENODEMISMATCH,  
 NODE\_Name is ACMSPAR does not match DECnet node name

This command displays entries from the Remote Manager error log on node VLCROW. Authorization is performed for the user specified by the logical name ACMS\$MGMT\_USER, or by proxy if the logical is not defined.

## 11.31. ACMSMGR SHOW EXC

### ACMSMGR SHOW EXC

ACMSMGR SHOW EXC — Displays information about an application on one or more remote nodes.

#### Format

ACMSMGR SHOW EXC [/qualifiers]

Command Qualifier	Default
/ACTIVE	See Notes.
/ALL	Current applications only.
/APPLICATION=application_name	* (all)
/[BRIEF,FULL]	/FULL if no class qualifier (/CONFIG, /ID, /POOL, or /RUNTIME ) is specified. Otherwise, /BRIEF.
/[class-name]	* (all)
/INTERVAL=interval	Command is executed once.
/NODE=node-name	Translation of logical ACMS \$MGMT_SERVER_NODE
/OUT=file-name	None
/STORED	See Notes.
/USER=user-name	Translation of logical ACMS\$MGMT_USER

#### Privileges Required

ACMS\$MGMT\_READ

#### Parameters

None.

#### Qualifiers

/ACTIVE

When specified with the /BRIEF qualifier, this qualifier causes active ACMSGEN field values to be displayed. /ACTIVE is effective only when used with the /CONFIG qualifier. If /BRIEF is not specified, or if /FULL is specified, this qualifier has no effect (both active and stored values are displayed).



**/ALL**

This qualifier displays all available application data, even data for applications that may no longer be running. When applications are stopped, the EXC table row they were occupying is marked for reuse. If the row has not been reused, the data remains available for display. This qualifier allows that data to be displayed. Inactive rows are flagged with an asterisk ( \* ) in the output.

To inhibit the display of old data, do not specify this qualifier. By default, only data for currently running processes is displayed.

**/APPLICATION=application-name**

This qualifier specifies a particular ACMS application to display. Wildcard matching is performed on the name provided; use of asterisks ( \* ) is allowed.

**/[BRIEF,FULL]**

This qualifier causes either summary (/BRIEF) or detailed (/FULL) information to be displayed. If no class qualifier (/CONFIG, /ERROR, /ID, /POOL, or /RUNTIME) is specified, this qualifier is ignored and all details are displayed (equivalent to /FULL). Available OpenVMS process quota and SYSGEN parameter information is only displayed when /FULL is specified.

**/[CONFIG,ERROR,ID,POOL,RUNTIME]**

This qualifier causes data for only the specified class to be displayed. If this qualifier is omitted, the default is to display information for all classes.

**/INTERVAL=interval**

This qualifier causes the command to be reissued automatically every interval seconds. Use either Ctrl/C or Ctrl/Y to interrupt the command. If this qualifier is not specified, the command is executed only once.

**/NODE=node-name**

This qualifier specifies a fully- or partially-qualified TCP/IP host name. This name must match the current DECnet host name. IP addresses and host names (or aliases) that exceed six characters or include mixed case are not allowed.

If the /NODE qualifier is not specified, the ACMSMGR utility checks for the presence of the logical name ACMS\$MGMT\_SERVER\_NODE. If the logical is defined, the value of the logical is used by default.

In order for the command to execute, either the /NODE qualifier must be provided on the command line, or the ACMS\$MGMT\_SERVER\_NODE logical must be defined.

**/OUT=file-name**

This qualifier causes output to be written to the specified file. If this qualifier is not specified, output is displayed to the terminal (SY\$OUTPUT).

**/STORED**

When specified with the /BRIEF qualifier, this qualifier causes field values from the ACMSGEN file (not those active in memory) to be displayed. The /STORED qualifier is effective only

when used with the /CONFIG qualifier. If /BRIEF is not specified, or if /FULL is specified, this qualifier has no effect (both active and stored values are displayed).

/USER=user-name

This qualifier specifies the name of the OpenVMS account on the server node to be used for authorization. If this qualifier is specified, an explicit login must already have been completed successfully (see Section 11.10).

If the /USER qualifier is not specified, the ACMSMGR utility checks for the presence of the logical name ACMS\$MGMT\_USER. If the logical is defined, the value of the logical is used by default.

If the /USER qualifier is not specified and the ACMS\$MGMT\_USER logical is not defined, the ACMSMGR utility attempts proxy access. See Section 4.4.1.2 for a discussion of proxy access.

## Notes

This command displays information about ACMS applications on the target node. The /BRIEF and /FULL qualifiers control the format of information to be displayed.

See Section 9.6 for a discussion of each field displayed.

Note that some information may not be current, depending on whether the class to which the data belongs has been enabled for the application. The Collect State field indicates whether or not information is being collected for that class.

## Examples

```
$ ACMSMGR SHOW EXC/ID
ACMS Remote Management -- Command line utility
ACMS V5.0 EXC Table Display                               Time: 18-APR-2001
13:59:09.33
      ID
      Node Class PID Process Name Start Time Application Name
-----
vlcrow enabled 37C0025A ACMS01EXC001000 18-APR-2001 14:49:49.22 LDT_APPL_A
gocrow enabled 38000249 ACMS01EXC001000 18-AUG-2001 15:07:23.51 LDT_APPL_B
```

This command displays summary IDENTIFICATION class information for all applications on the nodes specified by the logical name ACMS\$MGMT\_SERVER\_NODE. Authorization is performed for the user specified by the logical name ACMS\$MGMT\_USER, or by proxy if the logical is not defined.

# 11.32. ACMSMGR SHOW FILTER

## ACMSMGR SHOW FILTER

ACMSMGR SHOW FILTER — Displays the errors currently being filtered on one or more nodes. This command (and its qualifiers) is only for use with systems running ACMS Version 4.4 or higher.

### Format

ACMSMGR SHOW FILTER [/qualifiers]

Command Qualifier	Default
/INTERVAL=interval	Command is executed once.
/NODE=node-name	Translation of logical ACMS\$MGMT_SERVER_NODE
/OUT=file-name	None
/USER=user-name	Translation of logical ACMS\$MGMT_USER

## Privileges Required

ACMS\$MGMT\_READ

## Parameters

None.

## Qualifiers

/INTERVAL=interval

This qualifier causes the command to be reissued automatically at a specified interval (in seconds). Use either Ctrl/C or Ctrl/Y to interrupt the command. If this qualifier is not specified, the command is executed only once.

/NODE=node-name

This qualifier specifies a fully- or partially-qualified TCP/IP host name. This name must match the current DECnet host name. IP addresses and host names (or aliases) that exceed six characters or include mixed case are not allowed.

If the /NODE qualifier is not specified, the ACMSMGR utility checks for the presence of the logical name ACMS\$MGMT\_SERVER\_NODE. If the logical is defined, the value of the logical is used by default.

In order for the command to execute, either the /NODE qualifier must be provided on the command line, or the ACMS\$MGMT\_SERVER\_NODE logical must be defined.

/OUT=file-name

This qualifier causes output to be written to the specified file. If this qualifier is not specified, output is displayed to the terminal (SYS\$OUTPUT).

/USER=user-name

This qualifier specifies the name of the OpenVMS account on the server node to be used for authorization. If this qualifier is specified, an explicit login must already have been completed successfully (see Section 11.10).

If the /USER qualifier is not specified, the ACMSMGR utility checks for the presence of the logical name ACMS\$MGMT\_USER. If the logical is defined, the value of the logical is used by default.

If the /USER qualifier is not specified and the ACMS\$MGMT\_USER logical is not defined, the ACMSMGR utility attempts proxy access. See Section 4.4.1.2 for a discussion of proxy access.

## Notes

This command displays all system errors currently being filtered for the specified node or nodes.

## Examples

```
$ ACMSMGR SHOW FILTER /NODE=VLCROW
ACMS Remote Management -- Command line utility
ACMS V5.0 ACMS Error Filter Table Display      Time: 18-APR-2001
13:59:09.33
Node   Filtered Message Name (Code)
-----
-----
VLCROW ACMSACC-W-AUDSYSSTARTS ( FD8748)
VLCROW SYSTEM-W-TOOMUCHDATA ( 298)
VLCROW SYSTEM-W-NOMOREREG ( AE8)
```

This command displays the current errors being filtered for node VLCROW. When generated by an ACMS process on node VLCROW, these errors are not relayed to the Remote Manager.

# 11.33. ACMSMGR SHOW GROUP

## ACMSMGR SHOW GROUP

ACMSMGR SHOW GROUP — Displays information about one or more ACMS task groups on one or more nodes.

### Format

ACMSMGR SHOW GROUP [/qualifiers]

Command Qualifier	Default
/APPLICATION=application_name	* (all applications )
/[BRIEF,FULL]	/FULL if no class qualifier (/ID or /POOL ) is specified. Otherwise, /BRIEF.
/GROUP=group_name	* (all groups )
/[ID,POOL]	* (all )
/INTERVAL=interval	Command is executed once.
/NODE=node-name	Translation of logical ACMS \$MGMT_SERVER_NODE
/OUT=file-name	None
/USER=user-name	Translation of logical ACMS\$MGMT_USER

### Privileges Required

ACMS\$MGMT\_READ

### Parameters

None.

## Qualifiers

`/APPLICATION=application-name`

This qualifier specifies a particular ACMS application to display. Wildcard matching is performed on the name provided; use of asterisks (\*) is allowed.

`/[BRIEF,FULL]`

This qualifier causes either summary (`/BRIEF`) or detailed (`/FULL`) information to be displayed. If no class qualifier (`/ID` or `/POOL`) is specified, this qualifier is ignored and all details are displayed (equivalent to `/FULL`). If a class qualifier is used on the command, the default action provides a brief format display. Using `/FULL` with a class qualifier produces a full format display.

`/GROUP=group-name`

This qualifier specifies a particular ACMS task group to display. Wildcard matching is performed on the name provided; use of asterisks (\*) is allowed.

`/[ID, POOL]`

This qualifier causes data for only the specified class to be displayed. If this qualifier is omitted, the default is to display information for all classes.

`/INTERVAL=interval`

This qualifier causes the command to be reissued automatically at a specified interval (in seconds). Use either `Ctrl/C` or `Ctrl/Y` to interrupt the command. If this qualifier is not specified, the command is executed only once.

`/NODE=node-name`

This qualifier specifies a fully- or partially-qualified TCP/IP host name. This name must match the current DECnet host name. IP addresses and host names (or aliases) that exceed six characters or include mixed case are not allowed.

If the `/NODE` qualifier is not specified, the ACMSMGR utility checks for the presence of the logical name `ACMS$MGMT_SERVER_NODE`. If the logical is defined, the value of the logical is used by default.

In order for the command to execute, either the `/NODE` qualifier must be provided on the command line, or the `ACMS$MGMT_SERVER_NODE` logical must be defined.

`/OUT=file-name`

This qualifier causes output to be written to the specified file. If this qualifier is not specified, output is displayed to the terminal (`SY$OUTPUT`).

`/USER=user-name`

This qualifier specifies the name of the OpenVMS account on the server node to be used for authorization. If this qualifier is specified, an explicit login must already have been completed successfully (see Section 11.10).

If the `/USER` qualifier is not specified, the ACMSMGR utility checks for the presence of the logical name `ACMS$MGMT_USER`. If the logical is defined, the value of the logical is used by default.

If the /USER qualifier is not specified and the ACMSS\$MGMT\_USER logical is not defined, the ACMSMGR utility attempts proxy access. See Section 4.4.1.2 for a discussion of proxy access.

## Notes

This command displays information about ACMS application task groups on the target node. The /BRIEF and /FULL qualifiers control the format of information to be displayed.

See Section 9.12 for a discussion of each field displayed.

Note that some information may not be current, depending on whether the class to which the data belongs has been enabled for the task group. The Collect State field indicates whether or not information is being collected for that class.

## Examples

```
$ ACMSMGR SHOW GROUP/POOL
```

```
ACMS Remote Management -- Command line utility
ACMS V5.0 Task Group Table Display           Time: 18-APR-2001 13:59:36.35
  Pool      Application      -TWS Pool Free-      -TWS
  Pool Free-
  Node  Class      Name          Task Group Name  Current  Minimum
  Current Minimum
-----
-----
VLCROW  enabled  LDT_APPL_A   TEST_GRP01      99 %     99 %     99 %
  98 %
VLCROW  enabled  LDT_APPL_A   TLOAD001_GRP    97 %     97 %     98 %
  98 %
VLCROW  enabled  LDT_APPL_A   DBMS_LOAD_GRP   99 %     99 %     99 %
  99 %
VLCROW  enabled  LDT_APPL_A   RDB_LOAD_GRP    99 %     99 %     99 %
  98 %
VLCROW  enabled  LDT_APPL_A   RMSR_GRP        99 %     99 %     99 %
  98 %
VLCROW  enabled  LDT_APPL_A   TCT_ LDT_GROUP  99 %     90 %     98 %
  95 %
VLCROW  enabled  LDT_APPL_A   AT_TT_GROUP     99 %     99 %     99 %
  98 %
VLCROW  enabled  LDT_APPL_A   RI_FMS          99 %     99 %     99 %
  98 %
VLCROW  enabled  LDT_APPL_A   RI_SMG          99 %     99 %     99 %
  99 %
VLCROW  enabled  LDT_APPL_A   VF_GROUP        99 %     99 %     99 %
  98 %
VLCROW  enabled  LDT_APPL_A   CS_GROUP        99 %     99 %     99 %
  97 %
VLCROW  enabled  LDT_APPL_A   DT_GROUP        96 %     95 %     92 %
  89 %
VLCROW  enabled  LDT_APPL_A   VF_V32_GROUP    99 %     99 %     98 %
  97 %
VLCROW  enabled  LDT_APPL_A   DCL_CLI_GROUP   99 %     99 %     99 %
  98 %
VLCROW  enabled  LDT_APPL_A   DETASK_GROUP    99 %     99 %     99 %
  98 %
```

This command displays summary POOL class information for all task groups in all applications on the node specified by the logical name ACMS\$MGMT\_SERVER\_NODE. Authorization is performed for the user specified by the logical name ACMS\$MGMT\_USER, or by proxy if the logical is not defined.

## 11.34. ACMSMGR SHOW INTERFACE

### ACMSMGR SHOW INTERFACE

ACMSMGR SHOW INTERFACE — Displays Remote Manager interface (RPC or SNMP) information for a Remote Manager process on one or more nodes.

#### Format

ACMSMGR SHOW INTERFACE [/qualifiers]

Command Qualifier	Default
/INTERVAL=interval	Command is executed once.
/NODE=node-name	Translation of logical ACMS\$MGMT_SERVER_NODE
/OUT=file-name	None
/USER=user-name	Translation of logical ACMS\$MGMT_USER

#### Privileges Required

ACMS\$MGMT\_READ

#### Parameters

None.

#### Qualifiers

/INTERVAL=interval

This qualifier causes the command to be reissued automatically at a specified interval (in seconds). Use either Ctrl/C or Ctrl/Y to interrupt the command. If this qualifier is not specified, the command is executed only once.

/NODE=node-name

This qualifier specifies a fully- or partially-qualified TCP/IP host name. This name must match the current DECnet host name. IP addresses and host names (or aliases) that exceed six characters or include mixed case are not allowed.

If the /NODE qualifier is not specified, the ACMSMGR utility checks for the presence of the logical name ACMS\$MGMT\_SERVER\_NODE. If the logical is defined, the value of the logical is used by default.

In order for the command to execute, either the /NODE qualifier must be provided on the command line, or the ACMS\$MGMT\_SERVER\_NODE logical must be defined.

`/OUT=file-name`

This qualifier causes output to be written to the specified file. If this qualifier is not specified, output is displayed to the terminal (SYSS\$OUTPUT).

`/USER=user-name`

This qualifier specifies the name of the OpenVMS account on the server node to be used for authorization. If this qualifier is specified, an explicit login must already have been completed successfully (see Section 11.10).

If the `/USER` qualifier is not specified, the ACMSMGR utility checks for the presence of the logical name `ACMS$MGMT_USER`. If the logical is defined, the value of the logical is used by default.

If the `/USER` qualifier is not specified and the `ACMS$MGMT_USER` logical is not defined, the ACMSMGR utility attempts proxy access. See Section 4.4.1.2 for a discussion of proxy access.

## Notes

The ACMS Remote Manager supports two interfaces: RPC and SNMP. This command displays the running and enabled states of each interface, along with some counter and status information. See Section 9.8 for a discussion of each field displayed.

## Examples

```
$ ACMSMGR SHOW INTERFACE /NODE=VLCROW,GOCROW /USER=JONES
```

```
ACMS Remote Management -- Command line utility
ACMS V5.0 Interfaces Display                               Time: 18-APR-2001 13:59:15.51
Node   Interface State   State   Requests  Set      Alarms   Time Last
-----  -
Node   Interface State   State   Requests  Set      Alarms   Time Last
-----  -
vlcrow rpc      enabled started  987      0        0        17-NOV-1858
00:00:00.00
vlcrow snmp     enabled started   0        0        0        17-NOV-1858
00:00:00.00
gocrow rpc      enabled started  964      0        0        17-NOV-1858
00:00:00.00
gocrow snmp     enabled started   0        0        0        17-NOV-1858
00:00:00.00
```

This command displays information for the Remote Manager interfaces on nodes VLCROW and GOCROW. Authorization is performed for user JONES.

# 11.35. ACMSMGR SHOW LOG

## ACMSMGR SHOW LOG

ACMSMGR SHOW LOG — Displays Remote Manager log entries for a server on one or more nodes.

### Format

**ACMSMGR SHOW LOG** [`/qualifiers`]



Command Qualifier	Default
/BEFORE=time	End of file
/FACILITY=facility	All
/FILENAME=file-name	Translation of logical ACMS\$MGMT_LOG
/INTERVAL=interval	Command is executed once.
/LOCAL	Remote
/NODE=node-name	Translation of logical ACMS\$MGMT_SERVER_NODE
/OUT=file-name	None
/SEVERITY=[I,W,E,F]	All
/SINCE=time	Beginning of file
/USER=user-name	Translation of logical ACMS\$MGMT_USER

## Privileges Required

ACMS\$MGMT\_READ

## Parameters

None.

## Qualifiers

/BEFORE=time

This qualifier causes only audit log entries with a timestamp less than or equal to the time specified by *time* to be returned and displayed. The format of *time* is *DD-MMM-YY:HH:MM:SS.nn*. Partial dates and times (for example, 10-OCT or 09:00) are supported. If this qualifier is not specified, the search ends when the end of the audit file is reached.

/FACILITY=[DCL, LOG, MGR, MSG\_PROC, PROCMON, RPC, SEC, SNAP, SNMP, TRAP]

This qualifier causes only audit log entries with matching facilities to be displayed. If this qualifier is not specified, all facilities are returned.

/FILENAME=file-name

This qualifier allows log records to be displayed from a file other than the current log file. Specify a fully or partially qualified file specification.

/INTERVAL=interval

This qualifier causes the command to be reissued automatically at a specified interval (in seconds). Use either Ctrl/C or Ctrl/Y to interrupt the command. If this qualifier is not specified, the command is executed only once.

/LOCAL

This qualifier causes the ACMSMGR to open and read the audit log on the local node directly. You can use this qualifier if the Remote Manager process is not started. The /LOCAL qualifier overrides the /NODE qualifier and the ACMS\$MGMT\_SERVER\_NODE logical.

**/NODE=node-name**

This qualifier specifies a fully- or partially-qualified TCP/IP host name. This name must match the current DECnet host name. IP addresses and host names (or aliases) that exceed six characters or include mixed case are not allowed.

If the **/NODE** qualifier is not specified, the ACMSMGR utility checks for the presence of the logical name `ACMS$MGMT_SERVER_NODE`. If the logical is defined, the value of the logical is used by default.

In order for the command to execute, either the **/NODE** qualifier must be provided on the command line, or the `ACMS$MGMT_SERVER_NODE` logical must be defined.

**/OUT=file-name**

This qualifier causes output to be written to the specified file. If this qualifier is not specified, output is displayed to the terminal (`SY$OUTPUT`).

**/SEVERITY=[I, W, E, F]**

This qualifier causes only audit log entries with matching severities to be displayed. Valid severities are informational (I), warning (W), error (E), and fatal (F). If this qualifier is not specified, all severities are returned.

**/SINCE=time**

This qualifier causes only audit log entries with a timestamp greater than or equal to the time specified by *time* to be returned and displayed. The format of *time* is `DD-MMM-YY:HH:MM:SS.nn`. Partial dates and times (for example, 10- OCT or 09:00) are supported. If this qualifier is not specified, the search begins at the beginning of the audit file.

**/USER=user-name**

This qualifier specifies the name of the OpenVMS account on the server node to be used for authorization. If this qualifier is specified, an explicit login must already have been completed successfully (see Section 11.10).

If the **/USER** qualifier is not specified, the ACMSMGR utility checks for the presence of the logical name `ACMS$MGMT_USER`. If the logical is defined, the value of the logical is used by default.

If the **/USER** qualifier is not specified and the `ACMS$MGMT_USER` logical is not defined, the ACMSMGR utility attempts proxy access. See Section 4.4.1.2 for a discussion of proxy access

## Notes

This command displays Remote Manager audit file information. The format of the audit entries displayed is:

```
node time: facility: severity: error-text
```

In this format:

- *node* is the node from which the information was obtained.
- *time* is the time the entry was logged.
- *facility* is the facility that generated the entry.

- *severity* is the severity of the entry.
- *error-text* is the details of the entry.

## Examples

- ```
$ ACMSMGR SHOW LOG /NODE=VLCROW /SINCE="20-MAR-2001 11:00" -
_$/BEFORE="20-MAR-2001 12:00"
ACMS Remote Management -- Command line utility
ACMS V5.0 Log Display Time:          18-APR-2001 13:59:17.45
Node Message
vlcrow 20-MAR-2001 11:00:37.15 : log: i : Log opened
vlcrow 20-MAR-2001 11:02:29.43 : msg_proc: i : EXC shutdown. Attempting
to
    unmap application global section for ACMS01EXC001000
vlcrow 20-MAR-2001 11:02:29.43 : msg_proc: i : Application global
section
    unmapped for ACMS01EXC001000
vlcrow 20-MAR-2001 11:02:29.43 : msg_proc: i : EXC shutdown processing
complete for ACMS01EXC001000
vlcrow 20-MAR-2001 11:02:35.18 : msg_proc: i : CP process shutdown
message
    received for ACMS01CP001000
vlcrow 20-MAR-2001 11:02:38.40 : msg_proc: i : CP process shutdown
message
    received for ACMS01CP004000
vlcrow 20-MAR-2001 11:02:38.40 : msg_proc: i : CP process shutdown
message
    received for ACMS01CP003000
vlcrow 20-MAR-2001 11:02:38.40 : msg_proc: i : CP process shutdown
message
    received for ACMS01CP002000
vlcrow 20-MAR-2001 11:02:39.23 : msg_proc: i : TSC process shutdown
message
    received for ACMS01TSC001000
vlcrow 20-MAR-2001 11:02:41.93 : msg_proc: i : ACC process shutdown
message
    received for ACMS01ACC001000
vlcrow 20-MAR-2001 11:02:42.05 : procmon: w : ACC process is absent
after
    being present.
vlcrow 20-MAR-2001 11:03:00.23 : msg_proc: i : ACC process startup
message
    received for ACMS01ACC001000
vlcrow 20-MAR-2001 11:03:00.23 : msg_proc: e : Failure getting current
collection states. Ignoring process ACMS01ACC001000
vlcrow 20-MAR-2001 11:03:03.93 : msg_proc: i : TSC process startup
message
    received for ACMS01TSC001000
vlcrow 20-MAR-2001 11:03:10.03 : msg_proc: i : CP process startup
message
    received for ACMS01CP001000
vlcrow 20-MAR-2001 11:03:10.04 : msg_proc: i : CP process startup
message
    received for ACMS01CP002000
vlcrow 20-MAR-2001 11:03:10.04 : msg_proc: i : CP process startup
message
    received for ACMS01CP004000
```

```

vlcrow 20-MAR-2001 11:03:10.05 : msg_proc: i : CP process startup
message
    received for ACMS01CP003000
vlcrow 20-MAR-2001 11:03:31.87 : msg_proc: i : EXC startup. Attempting
to map
    application global section for ACMS01EXC001000
vlcrow 20-MAR-2001 11:03:31.87 : msg_proc: i : EXC startup processing
complete
    for ACMS01EXC001000
vlcrow 20-MAR-2001 11:03:51.28 : sec: w : Operator access attempt by
user
    vlcrow.zko.dec.com::LT_SUT [305,3] for function ACMSMGMT_STOP
vlcrow 20-MAR-2001 11:03:51.28 : rpc: e : Call to mgmt_shutdown complete
vlcrow 20-MAR-2001 11:03:51.28 : rpc: f : svc_run returned!
vlcrow 20-MAR-2001 11:03:51.48 : procmon: f : Failure waiting on
mgmt$x_proc_mon_cond_var
vlcrow 20-MAR-2001 11:03:51.50 : mgr: w : Rejected request to stop RPC
interface when it is already stopped.
vlcrow 20-MAR-2001 11:04:00.12 : log: i : Log opened
vlcrow 20-MAR-2001 11:04:02.08 : procmon: e : Failure obtaining current
collection states. Bypassingqti
vlcrow 20-MAR-2001 11:04:02.63 : msg_proc: i : Message proc thread
initializing
vlcrow 20-MAR-2001 11:04:02.63 : msg_proc: i : Message proc thread
starting
vlcrow 20-MAR-2001 11:04:02.63 : msg_proc: i : Message proc thread
executing
vlcrow 20-MAR-2001 11:04:03.14 : sec: e : Failure obtaining uaf info for
ACMS$SNMP
vlcrow 20-MAR-2001 11:04:03.20 : sec: e : %RMS-E-RNF, record not found
vlcrow 20-MAR-2001 11:04:03.20 : sec: e : Account verification failed
for
    ACMS$SNMP user
vlcrow 20-MAR-2001 11:25:53.20 : msg_proc: i : CP process shutdown
message
    received for ACMS01CP001000
vlcrow 20-MAR-2001 11:25:53.72 : msg_proc: i : CP process shutdown
message
    received for ACMS01CP003000
vlcrow 20-MAR-2001 11:25:53.72 : msg_proc: i : CP process shutdown
message
    received for ACMS01CP002000
vlcrow 20-MAR-2001 11:25:53.72 : msg_proc: i : CP process shutdown
message
    received for ACMS01CP004000
vlcrow 20-MAR-2001 11:26:07.51 : msg_proc: i : CP process shutdown
message
    received for ACMS01CP002000
vlcrow 20-MAR-2001 11:26:38.34 : msg_proc: i : TSC process shutdown
message
    received for ACMS01TSC001000

```

This command displays entries from the Remote Manager log on node VLCROW. Only entries that were logged between 11:00 AM and 12:00 PM on March 20, 2001, are displayed. Authorization is performed for the user specified by the logical name ACMS\$MGMT\_USER, or by proxy if the logical is not defined.

- \$ ACMSMGR SHOW LOG /SINCE=20-MAR /BEFORE=21-MAR

```
ACMS Remote Management -- Command line utility
ACMS V5.0 Log Display                               Time: 18-APR-2001
13:59:20.12
Node Message
local 20-MAR-2001 15:13:23.47 : msg_proc: i : CP process shutdown
message
    received for ACMS01CP001000
local 20-MAR-2001 15:13:25.57 : msg_proc: i : CP process shutdown
message
    received for ACMS01CP004000
local 20-MAR-2001 15:13:25.88 : msg_proc: i : CP process shutdown
message
    received for ACMS01CP002000
local 20-MAR-2001 15:13:41.77 : msg_proc: i : CP process shutdown
message
    received for ACMS01CP003000
local 20-MAR-2001 15:14:14.16 : msg_proc: i : CP process startup message
    received for ACMS01CP001000
local 20-MAR-2001 15:14:14.87 : msg_proc: i : CP process startup message
    received for ACMS01CP002000
local 20-MAR-2001 16:55:50.92 : log: i : Log opened
local 20-MAR-2001 16:55:53.44 : msg_proc: i : Message proc thread
    initializing
local 20-MAR-2001 16:55:53.44 : msg_proc: i : Message proc thread
    starting
local 20-MAR-2001 16:55:53.44 : msg_proc: i : Message proc thread
    executing
local 20-MAR-2001 16:55:54.49 : sec: f : ACMS$$SNMP user has been granted
    no rights.
local 20-MAR-2001 16:56:44.20 : sec: w : User does not hold the proper
    rights identifier -> vlcrow.zko.dec.com::LT_SUT [305,3]
local 20-MAR-2001 16:56:44.20 : rpc: w : Security check failed
local 20-MAR-2001 17:02:35.17 : sec: w : User does not hold the proper
    rights identifier -> vlcrow.zko.dec.com::LT_SUT [305,3]
local 20-MAR-2001 17:02:35.17 : rpc: w : Security check failed
local 20-MAR-2001 17:05:16.46 : sec: w : User does not hold the proper
    rights identifier -> vlcrow.zko.dec.com::LT_SUT [305,3]
local 20-MAR-2001 17:05:16.46 : rpc: w : Security check failed
local 20-MAR-2001 17:05:20.53 : sec: w : User does not hold the proper
    rights identifier -> vlcrow.zko.dec.com::LT_SUT [305,3]
local 20-MAR-2001 17:05:20.53 : rpc: w : Security check failed
local 20-MAR-2001 17:46:22.40 : msg_proc: i : ACC process startup
message
    received for ACMS01ACC001000
local 20-MAR-2001 17:46:22.42 : msg_proc: e : Failure getting current
    collection states. Ignoring process ACMS01ACC001000
local 20-MAR-2001 17:46:22.85 : procmon: e : Failure obtaining current
    collection states. Bypassingtsc
local 20-MAR-2001 17:46:22.85 : procmon: e : Failure obtaining current
    collection states. Bypassingqti
local 20-MAR-2001 17:46:25.92 : msg_proc: i : TSC process startup
message
    received for ACMS01TSC001000
```

This command displays entries from the Remote Manager log on node VLCROW. Only entries that were logged between March 20 and 21, 2001, are displayed. Authorization is performed for

the user specified by the logical name ACMS\$MGMT\_USER, or by proxy if the logical is not defined.

## 11.36. ACMSMGR SHOW MANAGER

### ACMSMGR SHOW MANAGER

ACMSMGR SHOW MANAGER — Displays run-time information about a Remote Manager on one or more nodes.

#### Format

ACMSMGR SHOW MANAGER [/qualifiers]

| Command Qualifier  | Default                                       |
|--------------------|-----------------------------------------------|
| /[BRIEF,FULL]      | /BRIEF                                        |
| /INTERVAL=interval | Command is executed once.                     |
| /NODE=node-name    | Translation of logical ACMS\$MGMT_SERVER_NODE |
| /OUT=file-name     | None                                          |
| /USER=user-name    | Translation of logical ACMS\$MGMT_USER        |

#### Privileges Required

ACMS\$MGMT\_READ

#### Parameters

None.

#### Qualifiers

/[BRIEF,FULL]

Specifies the format of the data displayed. /BRIEF is the default. /FULL qualifier displays timer information in addition to the information displayed in the brief display.

/INTERVAL=interval

This qualifier causes the command to be reissued automatically at a specified interval (in seconds). Use either Ctrl/C or Ctrl/Y to interrupt the command. If this qualifier is not specified, the command is executed only once.

/NODE=node-name

This qualifier specifies a fully- or partially-qualified TCP/IP host name. This name must match the current DECnet host name. IP addresses and host names (or aliases) that exceed six characters or include mixed case are not allowed.

If the /NODE qualifier is not specified, the ACMSMGR utility checks for the presence of the logical name ACMS\$MGMT\_SERVER\_NODE. If the logical is defined, the value of the logical is used by default.

In order for the command to execute, either the /NODE qualifier must be provided on the command line, or the ACMS\$MGMT\_SERVER\_NODE logical must be defined.

/OUT=file-name

This qualifier causes output to be written to the specified file. If this qualifier is not specified, output is displayed to the terminal (SYSS\$OUTPUT).

/USER=user-name

This qualifier specifies the name of the OpenVMS account on the server node to be used for authorization. If this qualifier is specified, an explicit login must already have been completed successfully (see Section 11.10).

If the /USER qualifier is not specified, the ACMSMGR utility checks for the presence of the logical name ACMS\$MGMT\_USER. If the logical is defined, the value of the logical is used by default.

If the /USER qualifier is not specified and the ACMS\$MGMT\_USER logical is not defined, the ACMSMGR utility attempts proxy access. See Section 4.4.1.2 for a discussion of proxy access.

## Notes

See Section 9.8 for a discussion of each field displayed.

## Examples

```
$ ACMSMGR SHOW MANAGER
ACMS Remote Management -- Command line utility
ACMS V5.0 Remote Manager Status Table Display Time: 18-APR-2001 13:59:22.76
Node          Fields
-----
VLCROW        Collection Count          0
VLCROW        Interfaces Count         2
VLCROW        Trap Count               0
VLCROW        RPC UDP State            1
VLCROW        RPC TCP State            1
VLCROW        Timer Count              0
```

This command displays summary information about the Remote Manager on the node specified by the logical name ACMS\$MGMT\_SERVER\_NODE. Authorization is performed for the user specified by the logical name ACMS\$MGMT\_USER, or by proxy if the logical is not defined.

# 11.37. ACMSMGR SHOW PARAMETER

## ACMSMGR SHOW PARAMETER

ACMSMGR SHOW PARAMETER — Displays Remote Manager configuration parameters for a server on one or more nodes.

## Format

### ACMSMGR SHOW PARAMETER [/qualifiers]

| Command Qualifier  | Default                                       |
|--------------------|-----------------------------------------------|
| /INTERVAL=interval | Command is executed once.                     |
| /NODE=node-name    | Translation of logical ACMS\$MGMT_SERVER_NODE |
| /OUT=file-name     | None                                          |
| /USER=user-name    | Translation of logical ACMS\$MGMT_USER        |

## Privileges Required

ACMS\$MGMT\_READ

## Parameters

None.

## Qualifiers

/INTERVAL=interval

This qualifier causes the command to be reissued automatically at a specified interval (in seconds). Use either Ctrl/C or Ctrl/Y to interrupt the command. If this qualifier is not specified, the command is executed only once.

/NODE=node-name

This qualifier specifies a fully- or partially-qualified TCP/IP host name. This name must match the current DECnet host name. IP addresses and host names (or aliases) that exceed six characters or include mixed case are not allowed.

If the /NODE qualifier is not specified, the ACMSMGR utility checks for the presence of the logical name ACMS\$MGMT\_SERVER\_NODE. If the logical is defined, the value of the logical is used by default.

In order for the command to execute, either the /NODE qualifier must be provided on the command line, or the ACMS\$MGMT\_SERVER\_NODE logical must be defined.

/OUT=file-name

This qualifier causes output to be written to the specified file. If this qualifier is not specified, output is displayed to the terminal (SY\$OUTPUT).

/USER=user-name

This qualifier specifies the name of the OpenVMS account on the server node to be used for authorization. If this qualifier is specified, an explicit login must already have been completed successfully (see Section 11.10).

If the /USER qualifier is not specified, the ACMSMGR utility checks for the presence of the logical name ACMS\$MGMT\_USER. If the logical is defined, the value of the logical is used by default.



If the /USER qualifier is not specified and the ACMS\$MGMT\_USER logical is not defined, the ACMSMGR utility attempts proxy access. See Section 4.4.1.2 for a discussion of proxy access.

## Notes

See Section 9.9 for a description of each parameter.

## Examples

```
$ ACMSMGR SHOW PARAMETER /NODE=VLCROW
ACMS Remote Management -- Command line utility
ACMS V5.0 Parameters Table Display           Time: 18-APR-2001 13:59:24.79
Node      Parameter                Value   Default  Min     Max
Units
-----
VLCROW    dcl_audit_level          E       E         0       F
(D)
VLCROW    dcl_mgr_priority         5       5         1       10
VLCROW    dcl_stacksize            300     300       1       2147483647
k (Vax), 8k (Alpha)
VLCROW    event_log_priority       5       5         1       10
VLCROW    error_interval           10      10        1       863999999
seconds (D)
VLCROW    log_stacksize            300     300       1       2147483647
K (Vax), 8k (Alpha)
VLCROW    login_creds_lifetime     60      60        1       14399999
minutes (D)
VLCROW    max_logins                20      20        1       2147483647
(D)
VLCROW    max_rpc_return_recs     20      20        1       2147483647
VLCROW    mgr_audit_level          E       E         0       F
(D)
VLCROW    msg_proc_audit_level     E       E         0       F
(D)
VLCROW    msg_proc_priority        5       5         1       10
VLCROW    msg_proc_stacksize      300     300       1       2147483647
k (Vax), 8k (Alpha)
VLCROW    mss_coll_interval        10      10        1       863999999
seconds (D)
VLCROW    proc_mon_audit_level     E       E         0       F
(D)
VLCROW    proc_mon_interval        3       30        1       14399999
seconds (D)
VLCROW    proc_mon_priority        5       5         1       10
VLCROW    proc_mon_stacksize      300     300       1       2147483647
K (Vax), 8k (Alpha)
VLCROW    proxy_creds_lifetime     60      60        1       14399999
minutes (D)
VLCROW    rpc_audit_level          E       E         0       F
(D)
VLCROW    rpc_priority             5       5         1       10
VLCROW    rpc_stacksize            30      300       1       2147483647
k (Vax), 8k (Alpha)
VLCROW    security_audit_level     E       E         0       F
(D)
VLCROW    vsnap_audit_level        E       E         0       F
(D)
```

|        |                       |     |     |   |            |
|--------|-----------------------|-----|-----|---|------------|
| VLCROW | vsnap_priority        | 5   | 5   | 1 | 10         |
| VLCROW | snap_stacksize        | 300 | 300 | 1 | 2147483647 |
|        | k (Vax), 8k (Alpha)   |     |     |   |            |
| VLCROW | snmp_agent_time_out   | 10  | 10  | 1 | 863999999  |
|        | seconds               |     |     |   |            |
| VLCROW | snmp_are_you_there    | 300 | 300 | 2 | 863999999  |
|        | seconds               |     |     |   |            |
| VLCROW | snmp_audit_level      | E   | E   | 0 | F          |
|        | (D)                   |     |     |   |            |
| VLCROW | snmp_priority         | 5   | 5   | 1 | 10         |
| VLCROW | snmp_sel_time_out     | 5   | 5   | 1 | 863999999  |
|        | seconds               |     |     |   |            |
| VLCROW | snmp_stacksize        | 300 | 300 | 1 | 2147483647 |
|        | k (Vax), 8k (Alpha)   |     |     |   |            |
| VLCROW | tcp_enabled           | 1   | 1   | 0 | 1          |
|        | [0,1] 1=enabled       |     |     |   |            |
| VLCROW | timer_audit_level     | E   | E   | 0 | F          |
|        | (D)                   |     |     |   |            |
| VLCROW | timer_interval        | 30  | 30  | 1 | 863999999  |
|        | seconds (D)           |     |     |   |            |
| VLCROW | timer_priority        | 5   | 5   | 1 | 10         |
| VLCROW | timer_stacksize       | 300 | 300 | 1 | 2147483647 |
|        | k (Vax), 8k (Alpha)   |     |     |   |            |
| VLCROW | total_entity_slots    | 20  | 20  | 1 | 2147483647 |
| VLCROW | trace_msg_wait_time   | 5   | 5   | 1 | 143999999  |
|        | seconds (D)           |     |     |   |            |
| VLCROW | trace_start_wait_time | 5   | 5   | 1 | 143999999  |
|        | seconds (D)           |     |     |   |            |
| VLCROW | trap_audit_level      | E   | E   | 0 | F          |
|        | (D)                   |     |     |   |            |
| VLCROW | trap_priority         | 5   | 5   | 1 | 10         |
| VLCROW | trap_stacksize        | 300 | 300 | 1 | 2147483647 |
|        | k (Vax), 8k (Alpha)   |     |     |   |            |
| VLCROW | udp_enabled           | 1   | 1   | 0 | 1          |
|        | [0,1] 1=enabled       |     |     |   |            |
| VLCROW | vms_coll_interval     | 10  | 10  | 0 | 863999999  |
|        | seconds (D)           |     |     |   |            |
| VLCROW | wksp_coll_interval    | 10  | 10  | 1 | 863999999  |
|        | seconds (D)           |     |     |   |            |
| VLCROW | max_agents            | 2   | 2   | 1 | 2147483647 |

This command displays data from the Remote Manager Parameter table on node VLCROW. Authorization is performed on the user specified by the logical name ACMS\$MGMT\_USER, or by proxy if the logical is not defined.

## 11.38. ACMSMGR SHOW PROCESS

### ACMSMGR SHOW PROCESS

ACMSMGR SHOW PROCESS — Displays summary data collection information for processes on one or more nodes.

#### Format

ACMSMGR SHOW PROCESS [/qualifiers]

| Command Qualifier  | Default                                           |
|--------------------|---------------------------------------------------|
| /ALL               | Displays only currently running processes.        |
| /[BRIEF,FULL]      | Controls the format of data displayed.            |
| /INTERVAL=interval | Command is executed once.                         |
| /NODE=node-name    | Translation of logical ACMS<br>\$MGMT_SERVER_NODE |
| /OUT=file-name     | None                                              |
| /USER=user-name    | Translation of logical ACMS\$MGMT_USER            |

## Privileges Required

ACMS\$MGMT\_READ

## Parameters

None.

## Qualifiers

/ALL

This qualifier displays all available application data, even data for applications that may no longer be running. When applications are stopped, the table row they were occupying is marked for reuse. If the row has not been reused, the data remains available for display. This qualifier allows that data to be displayed. Inactive rows are flagged with an asterisk ( \* ) in the output.

To inhibit the display of old data, do not specify this qualifier. By default, only data for currently running processes is displayed.

/[BRIEF,FULL]

Specifies the format of the data displayed. /BRIEF is the default and displays data in tabular format.

/INTERVAL=interval

This qualifier causes the command to be reissued automatically at a specified interval (in seconds). Use either Ctrl/C or Ctrl/Y to interrupt the command. If this qualifier is not specified, the command is executed only once.

/NODE=node-name

This qualifier specifies a fully- or partially-qualified TCP/IP host name. This name must match the current DECnet host name. IP addresses and host names (or aliases) that exceed six characters or include mixed case are not allowed.

If the /NODE qualifier is not specified, the ACMSMGR utility checks for the presence of the logical name ACMS\$MGMT\_SERVER\_NODE. If the logical is defined, the value of the logical is used by default.

In order for the command to execute, either the /NODE qualifier must be provided on the command line, or the ACMS\$MGMT\_SERVER\_NODE logical must be defined.

`/OUT=file-name`

This qualifier causes output to be written to the specified file. If this qualifier is not specified, output is displayed to the terminal (SYSS\$OUTPUT).

`/USER=user-name`

This qualifier specifies the name of the OpenVMS account on the server node to be used for authorization. If this qualifier is specified, an explicit login must already have been completed successfully (see Section 11.10).

If the `/USER` qualifier is not specified, the ACMSMGR utility checks for the presence of the logical name `ACMS$MGMT_USER`. If the logical is defined, the value of the logical is used by default.

If the `/USER` qualifier is not specified and the `ACMS$MGMT_USER` logical is not defined, the ACMSMGR utility attempts proxy access. See Section 4.4.1.2 for a discussion of proxy access.

## Notes

This command displays the current data-collection states for all process entry slots. Both active and inactive process data is displayed. Inactive data is flagged with an asterisk (\*) in the first column. The following fields are displayed:

- **Server Node:** The node from which the information was fetched.
- **Entity Type:** The ACMS entity type to which the data belongs.
- **PID:** The OpenVMS PID of the process.
- **Process Name:** The process name for the process.
- **Collection States:** The current collection state of the process for each class (Id, Cfg, RT and POOL). Collection states are displayed as binary values.
  - 0 = Collection is currently disabled.
  - 1 = Collection is currently enabled.

Previously, the `SHOW PROCESS/BRIEF` and `SHOW PROCESS/FULL` commands displayed all collection states for entities even when some were not applicable. You can enable/disable collection states for all classes and all entities. However, some combinations have no effect. These states are now shown in the `SHOW PROCESS/BRIEF` display as a "-", and as "N/A" for the `SHOW PROCESS/FULL` command. The display for the `SHOW PROCESS` command in the WEB display has also been modified.

For Task Groups, the following classes are not applicable: `CONFIG`, `RUNTIME`, `ERROR`. For Servers, the following classes are not applicable: `POOL`, `ERROR`.

## Examples

```
$ ACMSMGR SHOW PROCESS
ACMS Remote Management -- Command line utility
ACMS V5.0 Process Table Display                Time: 18-APR-2001
13:59:26.77
Server Entity          Process Name -or- Application.          Collection
States
```

| Node   | Type | PID      | [server_name, task_group_name] | ID | Cfg | RT |
|--------|------|----------|--------------------------------|----|-----|----|
| Pool   | Err  |          |                                |    |     |    |
| VLCROW | acc  | 37C0024F | ACMS01ACC001000                | 1  | 1   | 1  |
| 1      | 1    |          |                                |    |     |    |
| VLCROW | tsc  | 37C00251 | ACMS01TSC001000                | 1  | 1   | 1  |
| 1      | 1    |          |                                |    |     |    |
| VLCROW | cp   | 37C00252 | ACMS01CP001000                 | 1  | 1   | 1  |
| 1      | 1    |          |                                |    |     |    |
| VLCROW | cp   | 37C00253 | ACMS01CP002000                 | 1  | 1   | 1  |
| 1      | 1    |          |                                |    |     |    |
| VLCROW | cp   | 37C00254 | ACMS01CP003000                 | 1  | 1   | 1  |
| 1      | 1    |          |                                |    |     |    |
| VLCROW | cp   | 37C00255 | ACMS01CP004000                 | 1  | 1   | 1  |
| 1      | 1    |          |                                |    |     |    |
| VLCROW | exc  | 37C0025A | ACMS01EXC001000                | 1  | 1   | 1  |
| 1      | 1    |          |                                |    |     |    |
| VLCROW |      | server   | LDT_APPL_A.TESTSRV01           | 1  | 1   | 1  |
| 1      | 1    |          |                                |    |     |    |
| VLCROW |      | group    | LDT_APPL_A.TEST_GRP01          | 1  | 1   | 0  |
| 1      | 1    |          |                                |    |     |    |

This command displays Collection state information on a per-process basis from the node specified by the logical name ACMS\$MGMT\_SERVER\_NODE. Authorization is performed for the user specified by the logical name ACMS\$MGMT\_USER, or by proxy if the logical is not defined.

## 11.39. ACMSMGR SHOW QTI

### ACMSMGR SHOW QTI

ACMSMGR SHOW QTI — Displays information about QTIs on one or more remote nodes.

#### Format

ACMSMGR SHOW QTI [/qualifiers]

| Command Qualifier  | Default                                                                                                                        |
|--------------------|--------------------------------------------------------------------------------------------------------------------------------|
| /ACTIVE            | See Notes.                                                                                                                     |
| /ALL               | Current process data only.                                                                                                     |
| /[BRIEF,FULL]      | /FULL if no class /CLASS=keyword * (all).<br>qualifier (/CONFIG, /ID, /POOL,<br>or /RUNTIME ) is specified. Otherwise, /BRIEF. |
| /[class-name]      | * (all)                                                                                                                        |
| /INTERVAL=interval | Command is executed once.                                                                                                      |
| /NODE=node-name    | Translation of logical ACMS\$MGMT_SERVER_NODE                                                                                  |
| /OUT=file-name     | None                                                                                                                           |
| /STORED            | See Notes.                                                                                                                     |
| /USER=user-name    | Translation of logical ACMS\$MGMT_USER                                                                                         |

## Privileges Required

ACMS\$MGMT\_READ

## Parameters

None.

## Qualifiers

/ACTIVE

When specified with the /BRIEF qualifier, this qualifier causes active ACMSGEN field values to be displayed. /ACTIVE is effective only when used with the /CONFIG qualifier. If /BRIEF is not specified, or if /FULL is specified, this qualifier has no effect (both active and stored values are displayed).

/ALL

This qualifier displays all available QTI data, including data for processes that are no longer running. When QTI processes are stopped, the QTI table row they were occupying is marked for reuse. If the row has not been reused, the data remains available for display. This qualifier allows that data to be displayed. Inactive rows are flagged with an asterisk ( \* ) in the output.

To inhibit the display of old data, do not specify this qualifier. By default, only data for currently running processes is displayed.

/[BRIEF,FULL]

This qualifier causes either summary (/BRIEF) or detailed (/FULL) information to be displayed. If no class qualifier (/CONFIG, /ERROR, /ID, /POOL, or /RUNTIME) is specified, this qualifier is ignored and all details are displayed (equivalent to /FULL). Available OpenVMS process quota and SYSGEN parameter information is only displayed when /FULL is specified.

/[class-name]

This qualifier causes data for only the specified class to be displayed. If this qualifier is omitted, the default is to display information for all classes.

/INTERVAL=interval

This qualifier causes the command to be reissued automatically at a specified interval (in seconds). Use either Ctrl/C or Ctrl/Y to interrupt the command. If this qualifier is not specified, the command is executed only once.

/NODE=node-name

This qualifier specifies a fully- or partially-qualified TCP/IP host name. This name must match the current DECnet host name. IP addresses and host names (or aliases) that exceed six characters or include mixed case are not allowed.

If the /NODE qualifier is not specified, the ACMSMGR utility checks for the presence of the logical name ACMS\$MGMT\_SERVER\_NODE. If the logical is defined, the value of the logical is used by default.

In order for the command to execute, either the /NODE qualifier must be provided on the command line, or the ACMS\$MGMT\_SERVER\_NODE logical must be defined.

/OUT=file-name

This qualifier causes output to be written to the specified file. If this qualifier is not specified, output is displayed to the terminal (SYSS\$OUTPUT).

/STORED

When specified with the /BRIEF qualifier, this qualifier causes field values from the ACMSGEN file (not those active in memory) to be displayed. The /STORED qualifier is effective only when used with the /CONFIG qualifier. If /BRIEF is not specified, or if /FULL is specified, this qualifier has no effect (both active and stored values are displayed).

/USER=user-name

This qualifier specifies the name of the OpenVMS account on the server node to be used for authorization. If this qualifier is specified, an explicit login must already have been completed successfully (see Section 11.10).

If the /USER qualifier is not specified, the ACMSMGR utility checks for the presence of the logical name ACMS\$MGMT\_USER. If the logical is defined, the value of the logical is used by default.

If the /USER qualifier is not specified and the ACMS\$MGMT\_USER logical is not defined, the ACMSMGR utility attempts proxy access. See Section 4.4.1.2 for a discussion of proxy access.

## Notes

This command displays information about the QTIs on the target nodes. The /BRIEF and /FULL qualifiers control the format of information to be displayed.

See Section 9.10 for a discussion of each field displayed.

Note that some information may not be current, depending on whether the class to which the data belongs has been enabled for the QTI. The Collect State field indicates whether or not information is being collected for that class.

## Examples

```
$ ACMSMGR SHOW QTI /NODE=KAZONS /RUNTIME
ACMS Remote Management -- Command line utility
ACMS V5.0 QTI Table Display Time: 18-APR-2001
13:41:11.09
      Runtime Started Current Task Tasks Tasks Current Errors
Node Class Queues Tasks Retries Success Failed Submitrs Queued
-----
-----
kazons enabled 3 17 4361 14859 5783 5 1329
```

This command displays summary run-time information for the QTI on node KAZONS. Authorization is performed for the user specified by the logical name ACMS\$MGMT\_USER, or by proxy if the logical is not defined.

# 11.40. ACMSMGR SHOW SERVER

## ACMSMGR SHOW SERVER

ACMSMGR SHOW SERVER — Displays information about one or more ACMS application server types on one or more nodes.

### Format

ACMSMGR SHOW SERVER [/qualifiers]

| Command Qualifier      | Default                                                                                   |
|------------------------|-------------------------------------------------------------------------------------------|
| /APPL=application-name | * (all applications )                                                                     |
| /[BRIEF,FULL]          | /FULL if no class qualifier (/CONFIG, /ID, or /RUNTIME ) is specified. Otherwise, /BRIEF. |
| /[class-name]          | * (all applications )                                                                     |
| /INTERVAL=interval     | Command is executed once.                                                                 |
| /NODE=node-name        | Translation of logical ACMS \$MGMT_SERVER_NODE                                            |
| /OUT=file-name         | None                                                                                      |
| /CLASS=keyword         | * (all ).                                                                                 |
| /SERVER=server-name    | * (all servers )                                                                          |
| /USER=user-name        | Translation of logical ACMS\$MGMT_USER.                                                   |

### Privileges Required

ACMS\$MGMT\_READ

### Parameters

None.

### Qualifiers

/APPL=application-name

Use this qualifier to specify a particular ACMS application to display. Wildcard matching is performed on the name provided; use of asterisks (\*) is allowed.

/[BRIEF,FULL]

This qualifier causes either summary (/BRIEF) or detailed (/FULL) information to be displayed. If no class qualifier (/CONFIG, /ERROR, /ID, or /RUNTIME) is specified, this qualifier is ignored and all details are displayed (equivalent to /FULL).

/[class-name]

This qualifier causes data for only the specified class to be displayed. If this qualifier is omitted, the default is to display information for all classes.



`/INTERVAL=interval`

This qualifier causes the command to be reissued automatically at a specified interval (in seconds). Use either Ctrl/C or Ctrl/Y to interrupt the command. If this qualifier is not specified, the command is executed only once.

`/NODE=node-name`

This qualifier specifies a fully- or partially-qualified TCP/IP host name. This name must match the current DECnet host name. IP addresses and host names (or aliases) that exceed six characters or include mixed case are not allowed.

If the `/NODE` qualifier is not specified, the ACMSMGR utility checks for the presence of the logical name `ACMS$MGMT_SERVER_NODE`. If the logical is defined, the value of the logical is used by default.

In order for the command to execute, either the `/NODE` qualifier must be provided on the command line, or the `ACMS$MGMT_SERVER_NODE` logical must be defined.

`/OUT=file-name`

This qualifier causes output to be written to the specified file. If this qualifier is not specified, output is displayed to the terminal (`SY$OUTPUT`).

`/SERVER=server-name`

This qualifier specifies a particular ACMS application server to display. Wildcard matching is performed on the name provided; use of asterisks (\*) is allowed.

`/USER=user-name`

This qualifier specifies the name of the OpenVMS account on the server node to be used for authorization. If this qualifier is specified, an explicit login must already have been completed successfully (see Section 11.10).

If the `/USER` qualifier is not specified, the ACMSMGR utility checks for the presence of the logical name `ACMS$MGMT_USER`. If the logical is defined, the value of the logical is used by default.

If the `/USER` qualifier is not specified and the `ACMS$MGMT_USER` logical is not defined, the ACMSMGR utility attempts proxy access. See Section 4.4.1.2 for a discussion of proxy access.

## Notes

This command displays information about ACMS application servers on the target node. The `/BRIEF` and `/FULL` qualifiers control the format of information to be displayed.

See Section 9.11 for a discussion of each field displayed.

Note that some information may not be current, depending on whether the class to which the data belongs has been enabled for the server. The Collect State field indicates whether or not information is being collected for that class.

## Examples

```
$ ACMSMGR SHOW SERVER /NODE=VLCROW /RUNTIME
```

```

ACMS Remote Management -- Command line utility
ACMS V5.0 SER Table Display                               Time: 18-APR-2001
13:59:33.60
      Runtime Application                               Current Waiting Server
Server
Node  Class  Name           Server Name           Servers Tasks  Starts
Failures
-----
VLCROW enabled LDT_APPL_A  TESTSRV01           2         0         2         0
VLCROW enabled LDT_APPL_A  TESTSRV1D          0         0        3419         0
VLCROW enabled LDT_APPL_A  TESTSRV2D          1         0         19          0
VLCROW enabled LDT_APPL_A  TESTSRV3D          1         0          1          0
VLCROW enabled LDT_APPL_A  TESTSRV05          0         0          0          0
VLCROW enabled LDT_APPL_A  TLOAD001S          4         0          6          0
VLCROW enabled LDT_APPL_A  TLOAD002S          1         0          1          0
VLCROW enabled LDT_APPL_A  DBMSLSRV1          1         0          1          0
VLCROW enabled LDT_APPL_A  DBMSLSRV2          1         0          1          0
VLCROW enabled LDT_APPL_A  RDBLSRV1           1         0         44          0
VLCROW enabled LDT_APPL_A  RMSRSERVER         1         0         33          0
VLCROW enabled LDT_APPL_A  TCT_LDT_PROC_SERVER 1         0          1          0
VLCROW enabled LDT_APPL_A  TCT_LDT_CHAIN_SERVER 1         0          1          0
VLCROW enabled LDT_APPL_A  TCT_LDT_DCL_SERVER 0         0          0          0
VLCROW enabled LDT_APPL_A  RI_DCL_SERVER       2         0          9          0
VLCROW enabled LDT_APPL_A  RI_V3016_FMS_SERVER 1         0          1          0
VLCROW enabled LDT_APPL_A  RI_V3016_RI_SERVER 1         0          1          0
VLCROW enabled LDT_APPL_A  VF_V3111_SERVER     0         0          0          0
VLCROW enabled LDT_APPL_A  LDT_CS_V3111_SERVER 3         0          3          0
VLCROW enabled LDT_APPL_A  TESTV32_RMS_SERVER 8         0         28          0
VLCROW enabled LDT_APPL_A  TESTV32_RDB_SERVER 8         0        375          0
VLCROW enabled LDT_APPL_A  TESTV32_DBMS_SERVER 8         0         47          0
VLCROW enabled LDT_APPL_A  TESTV32_SQL_SERVER 8         0        405          0
VLCROW enabled LDT_APPL_A  TESTV32_RM_SERVER  4         0          4          0
VLCROW enabled LDT_APPL_A  GEN_INPUT_SERVER    4         0         24          0
VLCROW enabled LDT_APPL_A  NOOP_SERVER         4         0          4          0
VLCROW enabled LDT_APPL_A  UNUSED_VF_V32       0         0          0          0
VLCROW enabled LDT_APPL_A  V_SERVER_W_DCL      1         0          1          0
VLCROW enabled LDT_APPL_A  I_SERVER_W_DCL      1         0          1          0
VLCROW enabled LDT_APPL_A  DETASK_SERVER       2         0          3          0

```

This command displays summary run-time information for all servers on node VLCROW. Authorization is performed for the user specified by the logical name ACMS\$MGMT\_USER, or by proxy if the logical is not defined.

## 11.41. ACMSMGR SHOW TRAP

### ACMSMGR SHOW TRAP

ACMSMGR SHOW TRAP — Displays SNMP trap configurations for one or more nodes.

#### Format

ACMSMGR SHOW TRAP [/qualifiers]

| Command Qualifier | Default |
|-------------------|---------|
|-------------------|---------|

|                    |                                               |
|--------------------|-----------------------------------------------|
| /INTERVAL=interval | Command is executed once.                     |
| /NODE=node-name    | Translation of logical ACMS\$MGMT_SERVER_NODE |
| /OUT=file-name     | None                                          |
| /USER=user-name    | Translation of logical ACMS\$MGMT_USER        |

## Privileges Required

ACMS\$MGMT\_READ

## Parameters

None.

## Qualifiers

/INTERVAL=interval

This qualifier causes the command to be reissued automatically at a specified interval (in seconds). Use either Ctrl/C or Ctrl/Y to interrupt the command. If this qualifier is not specified, the command is executed only once.

/NODE=node-name

This qualifier specifies a fully- or partially-qualified TCP/IP host name. This name must match the current DECnet host name. IP addresses and host names (or aliases) that exceed six characters or include mixed case are not allowed.

If the /NODE qualifier is not specified, the ACMSMGR utility checks for the presence of the logical name ACMS\$MGMT\_SERVER\_NODE. If the logical is defined, the value of the logical is used by default.

In order for the command to execute, either the /NODE qualifier must be provided on the command line, or the ACMS\$MGMT\_SERVER\_NODE logical must be defined.

/OUT=file-name

This qualifier causes output to be written to the specified file. If this qualifier is not specified, output is displayed to the terminal (SYS\$OUTPUT).

/USER=user-name

This qualifier specifies the name of the OpenVMS account on the server node to be used for authorization. If this qualifier is specified, an explicit login must already have been completed successfully (see Section 11.10).

If the /USER qualifier is not specified, the ACMSMGR utility checks for the presence of the logical name ACMS\$MGMT\_USER. If the logical is defined, the value of the logical is used by default.

If the /USER qualifier is not specified and the ACMS\$MGMT\_USER logical is not defined, the ACMSMGR utility attempts proxy access. See Section 4.4.1.2 for a discussion of proxy access.

## Notes

This command displays Remote Manager SNMP trap configuration information. SNMP traps are generated only if the SNMP interface is started. Changes to this table take effect immediately after they are processed.

See Section 9.13 for a description of each field displayed.

## Examples

```
$ ACMSMGR SHOW TRAP
ACMS Remote Management -- Command line utility
ACMS V5.0 Trap Table Display                               Time: 18-APR-2001
13:59:38.69
Node   Entity   Entity Name Parameter Min Max Sev Alarms Alarm Time
-----
VLCROW *      *           exists    1  -1 I   0      17-NOV-1858
00:00:00.00
```

This command displays SNMP traps that have been configured on the node specified by the logical name ACMS\$MGMT\_SERVER\_NODE. Authorization is performed for the user specified by the logical name ACMS\$MGMT\_USER, or by proxy if the logical is not defined.

# 11.42. ACMSMGR SHOW TSC

## ACMSMGR SHOW TSC

ACMSMGR SHOW TSC — Displays information about TSCs on one or more remote nodes.

### Format

ACMSMGR SHOW TSC [/qualifiers]

| Command Qualifier  | Default                                                                                |
|--------------------|----------------------------------------------------------------------------------------|
| /ACTIVE            | See Notes.                                                                             |
| /[BRIEF,FULL]      | /FULL if no class qualifier (/CONFIG, /ID, /POOL, or) is specified. Otherwise, /BRIEF. |
| /[class-name]      | * (all)                                                                                |
| /INTERVAL=interval | Command is executed once.                                                              |
| /NODE=node-name    | Translation of logical ACMS\$MGMT_SERVER_NODE                                          |
| /OUT=file-name     | None                                                                                   |
| /STORED            | See Notes.                                                                             |
| /USER=user-name    | Translation of logical ACMS\$MGMT_USER                                                 |

### Privileges Required

ACMS\$MGMT\_READ

## Parameters

None.

## Qualifiers

### /ACTIVE

When specified with the /BRIEF qualifier, this qualifier causes active ACMSGEN field values to be displayed. /ACTIVE is effective only when used with the /CONFIG qualifier. If /BRIEF is not specified, or if /FULL is specified, this qualifier has no effect (both active and stored values are displayed).

### /ALL

This qualifier displays all available TSC data, including data for processes that are no longer running. When TSC processes are stopped, the TSC table row they were occupying is marked for reuse. If the row has not been reused, the data remains available for display. This qualifier allows that data to be displayed. Inactive rows are flagged with an asterisk ( \* ) in the output.

To inhibit the display of old data, do not specify this qualifier. By default, only data for currently running processes is displayed.

### /[BRIEF,FULL]

This qualifier causes either summary (/BRIEF) or detailed (/FULL) information to be displayed. If no class qualifier (/CONFIG, /ERROR, /ID, /POOL, or /RUNTIME) is specified, this qualifier is ignored and all details are displayed (equivalent to /FULL). Available OpenVMS process quota and SYSGEN parameter information is only displayed when /FULL is specified.

### /[class-name]

This qualifier causes data for only the specified class to be displayed. If this qualifier is omitted, the default is to display information for all classes.

### /INTERVAL=interval

This qualifier causes the command to be reissued automatically at a specified interval (in seconds). Use either Ctrl/C or Ctrl/Y to interrupt the command. If this qualifier is not specified, the command is executed only once.

### /NODE=node-name

This qualifier specifies a fully- or partially-qualified TCP/IP host name. This name must match the current DECnet host name. IP addresses and host names (or aliases) that exceed six characters or include mixed case are not allowed.

If the /NODE qualifier is not specified, the ACMSMGR utility checks for the presence of the logical name ACMS\$MGMT\_SERVER\_NODE. If the logical is defined, the value of the logical is used by default.

In order for the command to execute, either the /NODE qualifier must be provided on the command line, or the ACMS\$MGMT\_SERVER\_NODE logical must be defined.

`/OUT=file-name`

This qualifier causes output to be written to the specified file. If this qualifier is not specified, output is displayed to the terminal (SYSS\$OUTPUT).

`/STORED`

When specified with the `/BRIEF` qualifier, this qualifier causes field values from the ACMSGEN file (not those active in memory) to be displayed. The `/STORED` qualifier is effective only when used with the `/CONFIG` qualifier. If `/BRIEF` is not specified, or if `/FULL` is specified, this qualifier has no effect (both active and stored values are displayed).

`/USER=user-name`

This qualifier specifies the name of the OpenVMS account on the server node to be used for authorization. If this qualifier is specified, an explicit login must already have been completed successfully (see Section 11.10).

If the `/USER` qualifier is not specified, the ACMSMGR utility checks for the presence of the logical name ACMS\$MGMT\_USER. If the logical is defined, the value of the logical is used by default.

If the `/USER` qualifier is not specified and the ACMS\$MGMT\_USER logical is not defined, the ACMSMGR utility attempts proxy access. See Section 4.4.1.2 for a discussion of proxy access.

## Notes

This command displays information about the TSCs on the target nodes. The `/BRIEF` and `/FULL` qualifiers control the format of information to be displayed.

`/ACTIVE` is the default when the CONFIG class is being displayed.

See Section 9.15 for a discussion of each field displayed.

Note that some information may not be current, depending on whether the class to which the data belongs has been enabled for the TSC. The Collect State field indicates whether or not information is being collected for that class.

## Examples

```

• $ ACMSMGR SHOW TSC /NODE=VLCROW /CONFIG
ACMS Remote Management -- Command line utility
ACMS V5.0 TSC Table Display                               Time: 18-APR-2001
13:59:43.00
      A  Config      Run                               CP   Max   Max TTS Perm
      Min
      Node          S   Class      State      User Name  Slots Logins Per CP  CPs
      CPIs
-----
VLCROW          A  enabled  started  LT$TSC_V31  20   400   20     4
0

```

This command displays summary Configuration class information for the TSC on node VLCROW. Authorization is performed for the user specified by the logical name ACMS

\$MGMT\_USER, or by proxy if the logical is not defined. Since the /FULL qualifier was not supplied, only summary information is displayed.

- ```

$ ACMSMGR SHOW TSC /NODE=VLCROW
ACMS Remote Management -- Command line utility
ACMS V5.0 TSC Table Display                               Time: 18-APR-2001
 13:59:40.62
=====
Node IDENTIFICATION
-----
-----
VLCROW ID Class Collection State      enabled
Process Name                          ACMS01TSC001000
PID                                    37C00251
User Name                              LT$TSC_V31
Start Time                            18-APR-2001 14:49:18.98
End Time                               (null)

Node CONFIGURATION
-----
-----
VLCROW Config Class Collection State  enabled
TSC Running State                    started
TSC Username                          LT$TSC_V31      LT$TSC_V31
TSC Base Priority                      4              4
CP Username                            LT$CP_V40      LT$CP_V40
CP Base Priority                        4              4
CP Slots                               20             20
Max Logins (D)                         400            400
Max TTS per CP (D)                     20             20
Permanent CPs (D)                      4              4
Min CP slots (D)                       0              0
Working Set Default                     65008          65001
Working Set Extent                      322992         90000
Working Set Quota                       65536          65536
AST Limit                               1999           1999
Byte Limit                              1775409        1777777
Direct I/O Limit                        15000          15000
Buffered I/O Limit                      10000          10000
Enqueue Limit                           10000          10000
Page File Quota                         500000         500000
Timer Queue Limit                       500            500

Node RUNTIME
-----
-----
VLCROW Runtime Class Collection State  enabled
Gauges                                Current      Max      Limit      Max Time
-----
-----
Logins                                2           4        60         18-APR-2001
 15:49:55.13
CP Slots Used                          4           4         4          18-APR-2001
 18:21:19.78
Terminals per CP (avg)                  1           1        20         14-APR-2001
 15:50:19.34

Process Quotas                          Current      Max      Limit      Max Time
-----
-----

```

```

Working Set Size          65008      65008      322992  18-APR-2001
 18:21:19.78
AST Limit                 4 ( 0%)    5 ( 0%)    1999    11-APR-2001
 15:50:19.34
Byte Limit                0 ( 0%)    0 ( 0%)   1775409  18-APR-2001
 18:21:19.78
Direct I/O Limit         0 ( 0%)    0 ( 0%)    15000   18-APR-2001
 18:21:19.78
Buffered I/O Limit       2 ( 0%)    2 ( 0%)    10000   18-APR-2001
 18:21:19.78
Enqueue Limit            0 ( 0%)    0 ( 0%)    10000   18-APR-2001
 18:21:19.78
File Limit                1 ( 0%)    1 ( 0%)     1001   18-APR-2001
 18:21:19.78
Page File Quota          6704 ( 1%) 6704 ( 1%) 500000   18-APR-2001
 18:21:19.78
Timer Queue Limit        3 ( 0%)    3 ( 0%)     500    11-APR-2001
 09:14:55.49
Channel Count            15         15

```

```
Node    POOL
```

```
-----
VLCROW Pool Class Collection State      enabled
```

```

      Process Pool                                Pct   Time
      -----
-----
      Pool Size                                  262144
      Current Free (bytes)                       259760 (99%)
      Minimum Free (bytes)                       259760 (99%) 19-APR-2001
13:59:32.98
      Largest Current Free Block (bytes)         65536
      Minimum Largest Free Block (bytes)         65536          19-APR-2001
13:59:32.98
      Allocation Failures                         0
      Garbage Collections                         0

```

```
Node    ERROR
```

```
-----
VLCROW Error Class Collection State      enabled
      Error Count                                0
      Last Error Message                         0
      Time of Last Error                         (null)

```

This command displays all Configuration class information for the TSC on node VLCROW. Authorization is performed for the user specified by the logical name ACMS\$MGMT\_USER, or by proxy if the logical is not defined. Since neither the /FULL nor the /BRIEF qualifier was supplied, and no specific class was selected, all TSC information is displayed.

## 11.43. ACMSMGR SHOW USER

### ACMSMGR SHOW USER

ACMSMGR SHOW USER — Displays Remote Manager user information for a server on one or more nodes. Information about both proxy and nonproxy users is displayed.



## Format

### ACMSMGR SHOW USER [/qualifiers]

Command Qualifier	Default
/[BRIEF,FULL]	/BRIEF
/INTERVAL=interval	Command is executed once.
/NODE=node-name	Translation of logical ACMS \$MGMT_SERVER_NODE
/OUT=file-name	None
/USER=user-name	Translation of logical ACMS\$MGMT_USER

## Privileges Required

ACMS\$MGMT\_READ

## Parameters

None.

## Qualifiers

/[BRIEF,FULL]

This qualifier causes detailed information about each user to be displayed. When the qualifier is omitted, only summary information is displayed.

/INTERVAL=interval

This qualifier causes the command to be reissued automatically at a specified interval (in seconds). Use either Ctrl/C or Ctrl/Y to interrupt the command. If this qualifier is not specified, the command is executed only once.

/NODE=node-name

This qualifier specifies a fully- or partially-qualified TCP/IP host name. This name must match the current DECnet host name. IP addresses and host names (or aliases) that exceed six characters or include mixed case are not allowed.

If the /NODE qualifier is not specified, the ACMSMGR utility checks for the presence of the logical name ACMS\$MGMT\_SERVER\_NODE. If the logical is defined, the value of the logical is used by default.

In order for the command to execute, either the /NODE qualifier must be provided on the command line, or the ACMS\$MGMT\_SERVER\_NODE logical must be defined.

/OUT=file-name

This qualifier causes output to be written to the specified file. If this qualifier is not specified, output is displayed to the terminal (SYS\$OUTPUT).

`/USER=user-name`

This qualifier specifies the name of the OpenVMS account on the server node to be used for authorization. If this qualifier is specified, an explicit login must already have been completed successfully (see Section 11.10).

If the `/USER` qualifier is not specified, the ACMSMGR utility checks for the presence of the logical name `ACMS$MGMT_USER`. If the logical is defined, the value of the logical is used by default.

If the `/USER` qualifier is not specified and the `ACMS$MGMT_USER` logical is not defined, the ACMSMGR utility attempts proxy access. See Section 4.4.1.2 for a discussion of proxy access.

## Notes

This command displays information about each user currently logged in to the Remote Manager server. The following fields are displayed:

- **Server Node:** The node from which the information was obtained.
- **Client Id:** A unique identifier for each client.
- **Username:** The name of the local (server node) account to which the user is logged in. This is the user name that is being used for authorization.
- **Proxy:** A flag indicating whether the user is logged in using an ACMS proxy. A value of zero (0) indicates that the login is not proxy based; a value of 1 indicates that the login is proxy based.
- **Login Node:** The node from which the client logged in. This node may not be the same as the server node.

If the `/FULL` qualifier is specified, the following additional information is displayed:

- **Credentials expiration:** The date and time at which the user's credentials will expire.
- **UIC:** The UIC of the account from which the login was initiated.
- **Proxy UIC:** The UIC of the account on the server node that is used for authorization.

## Examples

- ```
$ ACMSMGR SHOW USERS
ACMS Remote Management -- Command line utility
ACMS V5.0 User Table Display                               Time: 18-APR-2001
13:59:45.09
Server      Client   Login
Node       Id      Username   Proxy Node
-----
gocrow     16      LT_SUT     1      gocrow.zko.dec.com
gocrow     17      LT_SUT     1      vlcrow.zko.dec.com
vlcrow     16      LT_SUT     1      vlcrow.zko.dec.com
vlcrow     20      LT_SUT     1      vlcrow.zko.dec.com
```

This command displays summary information about users who have logged in to Remote Manager on the node specified by the logical name `ACMS$MGMT_SERVER_NODE`. Authorization is performed for the user specified by the logical name `ACMS$MGMT_USER`, or by proxy if the logical is not defined. In this example, all users logged in using proxy (Proxy = 1).

```

• $ ACMSMGR SHOW USERS /FULL /NODE=VLCROW
ACMS Remote Management -- Command line utility
ACMS V5.0 User Table Display                               Time: 18-APR-2001
13:59:47.07
Node              User Information
-----
VLCROW           Client id          16
                  Username          LT_SUT
                  Login Node        vlcrow.zko.dec.com
                  Credentials expiration 18-APR-2002 13:59:47.07
                  Proxy Flag       1
                  UIC           [208,40]
                  Proxy UIC      [197,3]

Node              User Information
-----
VLCROW           Client id          18
                  Username          LT_SUT
                  Login Node        vlcrow.zko.dec.com
                  Credentials expiration 18-APR-2001 14:44:01.02
                  Proxy Flag       1
                  UIC           [197,3]
                  Proxy UIC      [197,3]

```

This command displays all information about users who have logged in to Remote Manager on the node specified by the logical name `ACMS$MGMT_SERVER_NODE`. Authorization is performed for the user specified by the logical name `ACMS$MGMT_USER`, or by proxy if the logical is not defined. In this example, both users logged in using proxy (Proxy = 1).

## 11.44. ACMSMGR SHOW VERSION

### ACMSMGR SHOW VERSION

`ACMSMGR SHOW VERSION` — Displays the current version of ACMSMGR and its related software components. This command (and its qualifiers) is only for use with systems running ACMS Version 4.4 or higher.

#### Format

`ACMSMGR SHOW VERSION [/qualifiers]`

| Command Qualifier               | Default                                                        |
|---------------------------------|----------------------------------------------------------------|
| <code>/INTERVAL=interval</code> | Command is executed once.                                      |
| <code>/NODE=node-name</code>    | Translation of logical ACMS<br><code>\$MGMT_SERVER_NODE</code> |
| <code>/OUT=file-name</code>     | None                                                           |
| <code>/USER=user-name</code>    | Translation of logical ACMS<br><code>\$MGMT_USER</code>        |

#### Privileges Required

`ACMS$MGMT_READ`

## Parameters

None.

## Qualifiers

/INTERVAL=interval

This qualifier causes the command to be reissued automatically at a specified interval (in seconds). Use either Ctrl/C or Ctrl/Y to interrupt the command. If this qualifier is not specified, the command is executed only once.

/NODE=node-name

This qualifier specifies a fully- or partially-qualified TCP/IP host name. This name must match the current DECnet host name. IP addresses and host names (or aliases) that exceed six characters or include mixed case are not allowed.

If the /NODE qualifier is not specified, the ACMSMGR utility checks for the presence of the logical name ACMS\$MGMT\_SERVER\_NODE. If the logical is defined, the value of the logical is used by default.

In order for the command to execute, either the /NODE qualifier must be provided on the command line, or the ACMS\$MGMT\_SERVER\_NODE logical must be defined.

/OUT=file-name

This qualifier causes output to be written to the specified file. If this qualifier is not specified, output is displayed to the terminal (SYS\$OUTPUT).

/USER=user-name

This qualifier specifies the name of the OpenVMS account on the server node to be used for authorization. If this qualifier is specified, an explicit login must already have been completed successfully (see Section 11.10).

If the /USER qualifier is not specified, the ACMSMGR utility checks for the presence of the logical name ACMS\$MGMT\_USER. If the logical is defined, the value of the logical is used by default.

If the /USER qualifier is not specified and the ACMS\$MGMT\_USER logical is not defined, the ACMSMGR utility attempts proxy access. See Section 4.4.1.2 for a discussion of proxy access.

## Examples

```
$ ACMSMGR SHOW VERSION /NODE=GOCROW
ACMS Remote Management -- Command line utility
ACMS V5.0 ACMS Version Display          Time: 18-APR-2001 13:59:47.07
Node Version Information
-----
local      ACMSMGR Version          ACMS V5.0
GOCROW    ACMS Version             V5.0
          MGMT Header Version    2
          MGMT EXC Header Version 2
          MGMT Config File Version 2
```

This command displays the current version of the ACMSMGR installed locally as well as the location and version of the related software components.

## 11.45. ACMSMGR START EXC

### ACMSMGR START EXC

ACMSMGR START EXC — Starts an ACMS application on one or more remote nodes.

#### Format

ACMSMGR START EXC [/qualifiers]

| Command Qualifier             | Default                                       |
|-------------------------------|-----------------------------------------------|
| /APPLICATION=application-name | Qualifier is required.                        |
| /NODE=node-name               | Translation of logical ACMS\$MGMT_SERVER_NODE |
| /USER=user-name               | Translation of logical ACMS\$MGMT_USER        |

#### Privileges Required

ACMS\$MGMT\_OPER

#### Parameters

None.

#### Qualifiers

/APPLICATION=application-name

This required qualifier specifies a particular ACMS application to start. The full application name must be specified.

/NODE=node-name

This qualifier specifies a fully- or partially-qualified TCP/IP host name. This name must match the current DECnet host name. IP addresses and host names (or aliases) that exceed six characters or include mixed case are not allowed.

If the /NODE qualifier is not specified, the ACMSMGR utility checks for the presence of the logical name ACMS\$MGMT\_SERVER\_NODE. If the logical is defined, the value of the logical is used by default.

In order for the command to execute, either the /NODE qualifier must be provided on the command line, or the ACMS\$MGMT\_SERVER\_NODE logical must be defined.

/USER=user-name

This qualifier specifies the name of the OpenVMS account on the server node to be used for authorization. If this qualifier is specified, an explicit login must already have been completed successfully (see Section 11.10).

If the /USER qualifier is not specified, the ACMSMGR utility checks for the presence of the logical name ACMS\$MGMT\_USER. If the logical is defined, the value of the logical is used by default.

If the /USER qualifier is not specified and the ACMS\$MGMT\_USER logical is not defined, the ACMSMGR utility attempts proxy access. See Section 4.4.1.2 for a discussion of proxy access.

## Notes

This command is equivalent to the ACMSOPER command ACMS/START APPL. This command is executed synchronously. If the command completes successfully, the application has been started on the target nodes. If not, error messages are displayed.

## Examples

```
$ ACMSMGR START EXC/APPL=VR_APPL/NODE=SPARKS
```

This command starts the VR\_APPL application on node SPARKS.

# 11.46. ACMSMGR START QTI

## ACMSMGR START QTI

ACMSMGR START QTI — Starts an ACMS Queued Task Initiator (QTI) on one or more remote nodes.

## Format

ACMSMGR START QTI [/qualifiers]

| Command Qualifier | Default                                       |
|-------------------|-----------------------------------------------|
| /NODE=node-name   | Translation of logical ACMS\$MGMT_SERVER_NODE |
| /USER=user-name   | Translation of logical ACMS\$MGMT_USER        |

## Privileges Required

ACMS\$MGMT\_OPER

## Parameters

None.

## Qualifiers

/NODE=node-name

This qualifier specifies a fully- or partially-qualified TCP/IP host name. This name must match the current DECnet host name. IP addresses and host names (or aliases) that exceed six characters or include mixed case are not allowed.

If the /NODE qualifier is not specified, the ACMSMGR utility checks for the presence of the logical name ACMS\$MGMT\_SERVER\_NODE. If the logical is defined, the value of the logical is used by default.

In order for the command to execute, either the /NODE qualifier must be provided on the command line, or the ACMS\$MGMT\_SERVER\_NODE logical must be defined.

/USER=user-name

This qualifier specifies the name of the OpenVMS account on the server node to be used for authorization. If this qualifier is specified, an explicit login must already have been completed successfully (see Section 11.10).

If the /USER qualifier is not specified, the ACMSMGR utility checks for the presence of the logical name ACMS\$MGMT\_USER. If the logical is defined, the value of the logical is used by default.

If the /USER qualifier is not specified and the ACMS\$MGMT\_USER logical is not defined, the ACMSMGR utility attempts proxy access. See Section 4.4.1.2 for a discussion of proxy access.

## Notes

This command is equivalent to the ACMSOPER command ACMS/START QTI. This command is executed synchronously. If the command completes successfully, the application has been started on the target nodes. If not, error messages are displayed.

## Examples

```
$ ACMSMGR START QTI/NODE=SPARKS
```

This command starts the QTI on node SPARKS.

# 11.47. ACMSMGR START SYSTEM

## ACMSMGR START SYSTEM

ACMSMGR START SYSTEM — Starts an ACMS run-time system on one or more remote nodes.

### Format

ACMSMGR START SYSTEM [/qualifiers]

| Command Qualifier | Default                                       |
|-------------------|-----------------------------------------------|
| /NOAUDIT          | Start system with auditing enabled.           |
| /NODE=node-name   | Translation of logical ACMS\$MGMT_SERVER_NODE |
| /QTI              | Start system without QTI running.             |
| /NOTERMINALS      | Start system with TSC and CPs running.        |
| /USER=user-name   | Translation of logical ACMS\$MGMT_USER        |

### Privileges Required

ACMS\$MGMT\_OPER

## Parameters

None.

## Qualifiers

### /NOAUDIT

This qualifier starts the system with auditing disabled. If this qualifier is not specified, the system is started with auditing enabled.

There is no "/AUDIT" qualifier to start ACMS with auditing enabled. Rather as the notes below describe, just start ACMS without the /NOAUDIT qualifier in order for ACMS to start with auditing enabled.

### /NODE=node-name

This qualifier specifies a fully- or partially-qualified TCP/IP host name. This name must match the current DECnet host name. IP addresses and host names (or aliases) that exceed six characters or include mixed case are not allowed.

If the /NODE qualifier is not specified, the ACMSMGR utility checks for the presence of the logical name ACMS\$MGMT\_SERVER\_NODE. If the logical is defined, the value of the logical is used by default.

In order for the command to execute, either the /NODE qualifier must be provided on the command line, or the ACMS\$MGMT\_SERVER\_NODE logical must be defined.

### /QTI

This qualifier starts the system with QTI running. If this qualifier is not specified, the system is started with QTI in stopped state.

There is no "/NOQTI" qualifier to start ACMS with QTI stopped. Rather as the notes below describe, just start ACMS without the /QTI qualifier in order for ACMS to start with QTI stopped.

### /NOTERMINALS

This qualifier starts the system without the TSC and CPs running. If this qualifier is not specified, the system is started with the TSC and CPs running.

There is no "/TERMINALS" qualifier to start ACMS with the TSC and CPs running. Rather as the notes below describe, just start ACMS without the /NOTERMINALS qualifier in order for ACMS to start without the TSC and CPs running.

### /USER=user-name

This qualifier specifies the name of the OpenVMS account on the server node to be used for authorization. If this qualifier is specified, an explicit login must already have been completed successfully (see Section 11.10).

If the /USER qualifier is not specified, the ACMSMGR utility checks for the presence of the logical name ACMS\$MGMT\_USER. If the logical is defined, the value of the logical is used by default.



If the /USER qualifier is not specified and the ACMS\$MGMT\_USER logical is not defined, the ACMSMGR utility attempts proxy access. See Section 4.4.1.2 for a discussion of proxy access.

## Notes

This command is equivalent to the ACMSOPER command ACMS/START SYS. This command is executed synchronously. If the command completes successfully, the system has been started on the target nodes. If not, error messages are displayed.

If no qualifiers are specified with this command, the equivalent ACMSOPER command is ACMS/START SYS/NOQTI/TERMINALS/AUDIT. In other words, the default values for the ACMSMGR START SYS command are /AUDIT, /TERMINALS, and /NOQTI. If you want to override a default you may use /NOAUDIT, /NOTERMINALS, or /QTI however you may not specify any of the defaults directly. You may only select them by leaving out the qualifier and taking the default.

## Examples

```
$ ACMSMGR START SYSTEM/NODE=SPARKS/NOTERMINALS
```

This command starts the ACMS run-time system on node SPARKS, without the QTI, TSC, or CPs running.

# 11.48. ACMSMGR START TERMINALS

## ACMSMGR START TERMINALS

ACMSMGR START TERMINALS — Starts an ACMS TSC and any associated CPs on one or more remote nodes.

### Format

ACMSMGR START TERMINALS [/qualifiers]

| Command Qualifier | Default                                       |
|-------------------|-----------------------------------------------|
| /NODE=node-name   | Translation of logical ACMS\$MGMT_SERVER_NODE |
| /USER=user-name   | Translation of logical ACMS\$MGMT_USER        |

### Privileges Required

ACMS\$MGMT\_OPER

### Parameters

None.

### Qualifiers

/NODE=node-name

This qualifier specifies a fully- or partially-qualified TCP/IP host name. This name must match the current DECnet host name. IP addresses and host names (or aliases) that exceed six characters or include mixed case are not allowed.

If the /NODE qualifier is not specified, the ACMSMGR utility checks for the presence of the logical name ACMS\$MGMT\_SERVER\_NODE. If the logical is defined, the value of the logical is used by default.

In order for the command to execute, either the /NODE qualifier must be provided on the command line, or the ACMS\$MGMT\_SERVER\_NODE logical must be defined.

/USER=user-name

This qualifier specifies the name of the OpenVMS account on the server node to be used for authorization. If this qualifier is specified, an explicit login must already have been completed successfully (see Section 11.10).

If the /USER qualifier is not specified, the ACMSMGR utility checks for the presence of the logical name ACMS\$MGMT\_USER. If the logical is defined, the value of the logical is used by default.

If the /USER qualifier is not specified and the ACMS\$MGMT\_USER logical is not defined, the ACMSMGR utility attempts proxy access. See Section 4.4.1.2 for a discussion of proxy access.

## Notes

This command is equivalent to the ACMSOPER command ACMS/START TERMINALS. This command is executed synchronously. If the command completes successfully, the application has been started on the target nodes. If not, error messages are displayed.

## Examples

```
$ ACMSMGR START TERMINALS/NODE=SPARKS
```

This command starts the TSC on node SPARKS.

# 11.49. ACMSMGR START TRACE\_MONITOR

## ACMSMGR START TRACE\_MONITOR

ACMSMGR START TRACE\_MONITOR — This command requests the Remote Manager on the target nodes to start the ACMS\$TRACE\_MON process. The ACMS\$TRACE\_MON process is an intermediate process used by the Remote Manager to communicate with ACMS run-time processes to enable and disable collections.

## Format

ACMSMGR START TRACE\_MONITOR [/qualifiers]

| Command Qualifier | Default                                       |
|-------------------|-----------------------------------------------|
| /NODE=node-name   | Translation of logical ACMS\$MGMT_SERVER_NODE |
| /USER=user-name   | Translation of logical ACMS\$MGMT_USER        |

## Privileges Required

ACMS\$MGMT\_OPER

## Parameters

None.

## Qualifiers

`/NODE=node-name`

This qualifier specifies a fully- or partially-qualified TCP/IP host name. This name must match the current DECnet host name. IP addresses and host names (or aliases) that exceed six characters or include mixed case are not allowed.

If the `/NODE` qualifier is not specified, the ACMSMGR utility checks for the presence of the logical name `ACMS$MGMT_SERVER_NODE`. If the logical is defined, the value of the logical is used by default.

In order for the command to execute, either the `/NODE` qualifier must be provided on the command line, or the `ACMS$MGMT_SERVER_NODE` logical must be defined.

`/USER=user-name`

This qualifier specifies the name of the OpenVMS account on the server node to be used for authorization. If this qualifier is specified, an explicit login must already have been completed successfully (see Section 11.10).

If the `/USER` qualifier is not specified, the ACMSMGR utility checks for the presence of the logical name `ACMS$MGMT_USER`. If the logical is defined, the value of the logical is used by default.

If the `/USER` qualifier is not specified and the `ACMS$MGMT_USER` logical is not defined, the ACMSMGR utility attempts proxy access. See Section 4.4.1.2 for a discussion of proxy access.

## Notes

This command requests the Remote Manager to start the `ACMS$TRACE_MON` process on the target node. The `ACMS$TRACE_MON` process is an intermediate process used by the Remote Manager to communicate with ACMS run-time processes to enable and disable collections.

In general, external entities do not require a startup or shutdown request of the trace monitor process. The Remote Manager starts the trace monitor during process initialization and stops it during process shutdown. Additionally, the Remote Manager starts the trace monitor anytime it is needed if it is not already started. Once started, the trace monitor continues running until the Remote Manager shuts down.

After issuing the start command to the trace monitor, the Remote Manager waits for a period of up to `trace_start_wait_time` (a Parameter table parameter that is dynamic and expressed in seconds). If the trace monitor fails to start during that period, the ACMSMGR command returns an error.

## Examples

```
$ ACMSMGR START TRACE_MONITOR
```

This command starts the `ACMS$TRACE_MON` process on the node specified by the logical name `ACMS$MGMT_SERVER_NODE`. Authorization is performed for the user specified by the logical

name ACMS\$MGMT\_USER, or based on an ACMS proxy on the target node if the logical is not defined. If the process is successfully started, no messages are displayed.

## 11.50. ACMSMGR STOP EXC

### ACMSMGR STOP EXC

ACMSMGR STOP EXC — Stops an ACMS application on one or more remote nodes.

#### Format

ACMSMGR STOP EXC [/qualifiers]

| Command Qualifier             | Default                                        |
|-------------------------------|------------------------------------------------|
| /APPLICATION=application-name | Qualifier is required.                         |
| /CANCEL                       | Wait for executing tasks to complete.          |
| /NODE=node-name               | Translation of logical ACMS\$MGMT_SERVER_NODE. |
| /USER=user-name               | Translation of logical ACMS\$MGMT_USER.        |

#### Privileges Required

ACMS\$MGMT\_OPER

#### Parameters

None.

#### Qualifiers

/APPLICATION=application-name

This required qualifier specifies a particular ACMS application to start. The entire application name must be specified.

/CANCEL

This qualifier stops the application without waiting for currently executing tasks to complete. If this qualifier is omitted, any tasks currently executing are allowed to complete before the application is stopped.

/NODE=node-name

This qualifier specifies a fully- or partially-qualified TCP/IP host name. This name must match the current DECnet host name. IP addresses and host names (or aliases) that exceed six characters or include mixed case are not allowed.

If the /NODE qualifier is not specified, the ACMSMGR utility checks for the presence of the logical name ACMS\$MGMT\_SERVER\_NODE. If the logical is defined, the value of the logical is used by default.

In order for the command to execute, either the /NODE qualifier must be provided on the command line, or the ACMS\$MGMT\_SERVER\_NODE logical must be defined.

/USER=user-name

This qualifier specifies the name of the OpenVMS account on the server node to be used for authorization. If this qualifier is specified, an explicit login must already have been completed successfully (see Section 11.10).

If the /USER qualifier is not specified, the ACMSMGR utility checks for the presence of the logical name ACMS\$MGMT\_USER. If the logical is defined, the value of the logical is used by default.

If the /USER qualifier is not specified and the ACMS\$MGMT\_USER logical is not defined, the ACMSMGR utility attempts proxy access. See Section 4.4.1.2 for a discussion of proxy access.

## Notes

This command is equivalent to the ACMSOPER command ACMS/STOP APPL. This command is executed synchronously. If the command completes successfully, the application has been stopped on the target nodes. If not, error messages are displayed.

## Examples

```
$ ACMSMGR STOP EXC/APPL=VR_APPL/NODE=SPARKS
```

This command stops the VR\_APPL application on node SPARKS.

# 11.51. ACMSMGR STOP MANAGER

## ACMSMGR STOP MANAGER

ACMSMGR STOP MANAGER — Stops the Remote Manager on the target nodes.

### Format

ACMSMGR STOP MANAGER [/qualifiers]

| Command Qualifier | Default                                       |
|-------------------|-----------------------------------------------|
| /NODE=node-name   | Translation of logical ACMS\$MGMT_SERVER_NODE |
| /USER=user-name   | Translation of logical ACMS\$MGMT_USER        |

### Privileges Required

ACMS\$MGMT\_OPER

### Parameters

None.

## Qualifiers

`/NODE=node-name`

This qualifier specifies a fully- or partially-qualified TCP/IP host name. This name must match the current DECnet host name. IP addresses and host names (or aliases) that exceed six characters or include mixed case are not allowed.

If the `/NODE` qualifier is not specified, the ACMSMGR utility checks for the presence of the logical name `ACMS$MGMT_SERVER_NODE`. If the logical is defined, the value of the logical is used by default.

In order for the command to execute, either the `/NODE` qualifier must be provided on the command line, or the `ACMS$MGMT_SERVER_NODE` logical must be defined.

`/USER=user-name`

This qualifier specifies the name of the OpenVMS account on the server node to be used for authorization. If this qualifier is specified, an explicit login must already have been completed successfully (see Section 11.10).

If the `/USER` qualifier is not specified, the ACMSMGR utility checks for the presence of the logical name `ACMS$MGMT_USER`. If the logical is defined, the value of the logical is used by default.

If the `/USER` qualifier is not specified and the `ACMS$MGMT_USER` logical is not defined, the ACMSMGR utility attempts proxy access. See Section 4.4.1.2 for a discussion of proxy access.

## Notes

This command requests an orderly shutdown of the Remote Manager process. This command may take several minutes to complete if any of the interfaces is in a noninterruptible state when the command is issued.

If the command fails to complete successfully, an alternative means of stopping the Remote Manager is to use the DCL command `STOP/ID`.

The Remote Manager can be restarted only by logging in to the target node and running the `ACMS$MGMT_STARTUP` command procedure.

## Examples

```
$ ACMSMGR STOP MANAGER
```

This command stops the Remote Manager on the node specified by the logical name `ACMS$MGMT_SERVER_NODE`. Authorization is performed for the user specified by the logical `ACMS$MGMT_USER`, or is based on an ACMS proxy on the target node if the logical is not defined. If the server is successfully stopped, no messages are displayed.

# 11.52. ACMSMGR STOP QTI

## ACMSMGR STOP QTI

`ACMSMGR STOP QTI` — Stops an ACMS Queued Task Initiator (QTI) on one or more remote nodes.

## Format

ACMSMGR STOP QTI [/qualifiers]

| Command Qualifier | Default                                       |
|-------------------|-----------------------------------------------|
| /NODE=node-name   | Translation of logical ACMS\$MGMT_SERVER_NODE |
| /USER=user-name   | Translation of logical ACMS\$MGMT_USER        |

## Privileges Required

ACMS\$MGMT\_OPER

## Parameters

None.

## Qualifiers

/NODE=node-name

This qualifier specifies a fully- or partially-qualified TCP/IP host name. This name must match the current DECnet host name. IP addresses and host names (or aliases) that exceed six characters or include mixed case are not allowed.

If the /NODE qualifier is not specified, the ACMSMGR utility checks for the presence of the logical name ACMS\$MGMT\_SERVER\_NODE. If the logical is defined, the value of the logical is used by default.

In order for the command to execute, either the /NODE qualifier must be provided on the command line, or the ACMS\$MGMT\_SERVER\_NODE logical must be defined.

/USER=user-name

This qualifier specifies the name of the OpenVMS account on the server node to be used for authorization. If this qualifier is specified, an explicit login must already have been completed successfully (see Section 11.10).

If the /USER qualifier is not specified, the ACMSMGR utility checks for the presence of the logical name ACMS\$MGMT\_USER. If the logical is defined, the value of the logical is used by default.

If the /USER qualifier is not specified and the ACMS\$MGMT\_USER logical is not defined, the ACMSMGR utility attempts proxy access. See Section 4.4.1.2 for a discussion of proxy access.

## Notes

This command is equivalent to the ACMSOPER command ACMS/STOP QTI. This command is executed synchronously. If the command completes successfully, the QTI has been stopeed on the target nodes. If not, error messages are displayed.

## Examples

```
$ ACMSMGR STOP QTI/NODE=SPARKS
```

This command stops the QTI on node SPARKS.

## 11.53. ACMSMGR STOP SYSTEM

### ACMSMGR STOP SYSTEM

ACMSMGR STOP SYSTEM — Stops an ACMS run-time system on one or more remote nodes.

#### Format

ACMSMGR STOP SYSTEM [/qualifiers]

| Command Qualifier | Default                                           |
|-------------------|---------------------------------------------------|
| /CANCEL           | Wait for executing tasks to complete.             |
| /NODE=node-name   | Translation of logical ACMS<br>\$MGMT_SERVER_NODE |
| /USER=user-name   | Translation of logical ACMS\$MGMT_USER            |

#### Privileges Required

ACMS\$MGMT\_OPER

#### Parameters

None.

#### Qualifiers

/CANCEL

This qualifier stops the ACMS run-time system without waiting for currently executing tasks to complete. If not specified, any tasks currently executing are allowed to complete before the application is stopped.

/NODE=node-name

This qualifier specifies a fully- or partially-qualified TCP/IP host name. This name must match the current DECnet host name. IP addresses and host names (or aliases) that exceed six characters or include mixed case are not allowed.

If the /NODE qualifier is not specified, the ACMSMGR utility checks for the presence of the logical name ACMS\$MGMT\_SERVER\_NODE. If the logical is defined, the value of the logical is used by default.

In order for the command to execute, either the /NODE qualifier must be provided on the command line, or the ACMS\$MGMT\_SERVER\_NODE logical must be defined.

/USER=user-name

This qualifier specifies the name of the OpenVMS account on the server node to be used for authorization. If this qualifier is specified, an explicit login must already have been completed successfully (see Section 11.10).



If the /USER qualifier is not specified, the ACMSMGR utility checks for the presence of the logical name ACMS\$MGMT\_USER. If the logical is defined, the value of the logical is used by default.

If the /USER qualifier is not specified and the ACMS\$MGMT\_USER logical is not defined, the ACMSMGR utility attempts proxy access. See Section 4.4.1.2 for a discussion of proxy access.

## Notes

This command is equivalent to the ACMSOPER command ACMS/STOP SYSTEM. This command is executed synchronously. If the command completes successfully, the application has been stopped on the target nodes. If not, error messages are displayed.

## Examples

```
$ ACMSMGR STOP SYS/NODE=SPARKS/CANCEL
```

This command stops the ACMS run-time system on node SPARKS. All currently executing tasks, servers, and users are canceled. ACMSMGR

# 11.54. ACMSMGR STOP TERMINALS

## ACMSMGR STOP TERMINALS

ACMSMGR STOP TERMINALS — Stops the TSC and any related CPs on one or more remote nodes.

### Format

ACMSMGR STOP TERMINALS [/qualifiers]

| Command Qualifier | Default                                       |
|-------------------|-----------------------------------------------|
| /NODE=node-name   | Translation of logical ACMS\$MGMT_SERVER_NODE |
| /USER=user-name   | Translation of logical ACMS\$MGMT_USER        |

### Privileges Required

ACMS\$MGMT\_OPER

### Parameters

None.

### Qualifiers

/NODE=node-name

This qualifier specifies a fully- or partially-qualified TCP/IP host name. This name must match the current DECnet host name. IP addresses and host names (or aliases) that exceed six characters or include mixed case are not allowed.

If the /NODE qualifier is not specified, the ACMSMGR utility checks for the presence of the logical name ACMS\$MGMT\_SERVER\_NODE. If the logical is defined, the value of the logical is used by default.

In order for the command to execute, either the /NODE qualifier must be provided on the command line, or the ACMS\$MGMT\_SERVER\_NODE logical must be defined.

/USER=user-name

This qualifier specifies the name of the OpenVMS account on the server node to be used for authorization. If this qualifier is specified, an explicit login must already have been completed successfully (see Section 11.10).

If the /USER qualifier is not specified, the ACMSMGR utility checks for the presence of the logical name ACMS\$MGMT\_USER. If the logical is defined, the value of the logical is used by default.

If the /USER qualifier is not specified and the ACMS\$MGMT\_USER logical is not defined, the ACMSMGR utility attempts proxy access. See Section 4.4.1.2 for a discussion of proxy access.

## Notes

This command is equivalent to the ACMSOPER command ACMS/STOP TERMINALS. This command is executed synchronously. If the command completes successfully, the terminal subsystem has been stopped on the target nodes. If not, error messages are displayed.

## Examples

```
$ ACMSMGR STOP TERMINALS/NODE=SPARKS/CANCEL
```

This command stops the ACMS terminal subsystem on node SPARKS.

# 11.55. ACMSMGR STOP TRACE\_MONITOR

## ACMSMGR STOP TRACE\_MONITOR

ACMSMGR STOP TRACE\_MONITOR — Stops the ACMS\$TRACE\_MON process on the target node.

## Format

ACMSMGR STOP TRACE\_MONITOR [/qualifiers]

| Command Qualifier | Default                                       |
|-------------------|-----------------------------------------------|
| /NODE=node-name   | Translation of logical ACMS\$MGMT_SERVER_NODE |
| /USER=user-name   | Translation of logical ACMS\$MGMT_USER        |

## Privileges Required

ACMS\$MGMT\_OPER

## Parameters

None.

## Qualifiers

`/NODE=node-name`

This qualifier specifies a fully- or partially-qualified TCP/IP host name. This name must match the current DECnet host name. IP addresses and host names (or aliases) that exceed six characters or include mixed case are not allowed.

If the `/NODE` qualifier is not specified, the ACMSMGR utility checks for the presence of the logical name `ACMS$MGMT_SERVER_NODE`. If the logical is defined, the value of the logical is used by default.

In order for the command to execute, either the `/NODE` qualifier must be provided on the command line, or the `ACMS$MGMT_SERVER_NODE` logical must be defined.

`/USER=user-name`

This qualifier specifies the name of the OpenVMS account on the server node to be used for authorization. If this qualifier is specified, an explicit login must already have been completed successfully (see Section 11.10).

If the `/USER` qualifier is not specified, the ACMSMGR utility checks for the presence of the logical name `ACMS$MGMT_USER`. If the logical is defined, the value of the logical is used by default.

If the `/USER` qualifier is not specified and the `ACMS$MGMT_USER` logical is not defined, the ACMSMGR utility attempts proxy access. See Section 4.4.1.2 for a discussion of proxy access.

## Notes

This command requests the Remote Manager to stop the `ACMS$TRACE_MON` process on the target node. The `ACMS$TRACE_MON` process is an intermediate process used by the Remote Manager to communicate with ACMS run-time processes to enable and disable collections.

In general, external entities do not require a startup or shutdown request of the trace monitor process. The Remote Manager starts the trace monitor during process initialization and stops it during process shutdown. Additionally, the Remote Manager starts the trace monitor anytime it is needed if it is not already started. Once started, the trace monitor continues running until the Remote Manager shuts down.

After issuing the stop command to the trace monitor, the Remote Manager waits for a period of up to `trace_start_wait_time` (a Parameter table parameter that is dynamic and expressed in seconds). If the trace monitor fails to stop during that period, the ACMSMGR command returns an error.

## Examples

```
$ ACMSMGR STOP TRACE_MONITOR
```

This command stops the `ACMS$TRACE_MON` process on the node specified by the logical name `ACMS$MGMT_SERVER_NODE`. Authorization is performed for the user specified by the logical

name ACMS\$MGMT\_USER, or based on an ACMS proxy on the target node if the logical is not defined. If the process is successfully stopped, no messages are displayed.

# Chapter 12. ACMSSNAP Commands

This chapter provides reference information about ACMSSNAP utility commands. Note that this utility and its commands are designed to run locally on a Remote Manager Version 4.4 or higher system.

## 12.1. ACMSSNAP Overview

The ACMSSNAP utility is used to display information collected in an ACMS Remote Manager data snapshot file. ACMSSNAP runs locally and requires local access to data snapshot files. This means that although a data snapshot file may have been created on a remote node, that file must be directly accessible to the local process running the ACMSSNAP utility.

The ACMSSNAP utility only displays information from the data snapshot file. It does not modify the data in the file or make modifications to the ACMS run-time system.

### 12.1.1. Command Format

The format for ACMSSNAP commands is as follows:

```
ACMSSNAP> verb object qualifiers
```

The following verbs are supported:

- CLOSE
- EXIT
- HELP
- NEXT
- OPEN
- PREV
- QUIT
- RESET
- SHOW
- TRACE

Most verbs have associated objects and qualifiers. The following sections list the objects and any qualifiers for each ACMSSNAP command.

### 12.1.2. Command Objects and Qualifiers

The objects and qualifiers for the ACMSSNAP commands are summarized in the table below.

**Table 12.1. ACMSSNAP Command Objects and Qualifiers**

| Objects       | Qualifiers |
|---------------|------------|
| CLOSE Command |            |

| <b>Objects</b>       | <b>Qualifiers</b>                                                                |
|----------------------|----------------------------------------------------------------------------------|
| None                 | None                                                                             |
| <b>EXIT Command</b>  |                                                                                  |
| None                 | None                                                                             |
| <b>HELP Command</b>  |                                                                                  |
| None                 | None                                                                             |
| <b>NEXT Command</b>  |                                                                                  |
| [number]             | None                                                                             |
| <b>OPEN Command</b>  |                                                                                  |
| [file-name]          | /AT, /CP_SLOTS, /MAX_AGENTS, /<br>MAX_APPL, /SUMMARY                             |
| <b>PREV Command</b>  |                                                                                  |
| [number]             | None                                                                             |
| <b>QUIT Command</b>  |                                                                                  |
| None                 | None                                                                             |
| <b>RESET Command</b> |                                                                                  |
| None                 | /ALL                                                                             |
| <b>SHOW Command</b>  |                                                                                  |
| ACC                  | /AT, /BRIEF, /CONFIG, /FULL, /ID, /NEXT, /<br>OUT, /POOL, /PREV, /RUNTIME        |
| AGENT                | /AT, /BRIEF, /CONFIG, /FULL, /ID, /NEXT, /<br>OUT, /POOL, /PREV, /RUNTIME        |
| CP                   | /AT, /BRIEF, /CONFIG, /FULL, /ID, /NEXT, /<br>OUT, /POOL, /PREV, /RUNTIME        |
| EXC                  | /APPL, /AT, /BRIEF, /CONFIG, /FULL, /ID, /<br>NEXT, /OUT, /POOL, /PREV, /RUNTIME |
| GROUP                | /APPL, /AT, /BRIEF, /CONFIG, /FULL, /ID, /<br>NEXT, /OUT, /POOL, /PREV, /RUNTIME |
| QTI                  | /AT, /BRIEF, /CONFIG, /FULL, /ID, /NEXT, /<br>OUT, /POOL, /PREV, /RUNTIME        |
| SERVER               | /APPL, /AT, /BRIEF, /CONFIG, /FULL, /ID, /<br>NEXT, /OUT, /POOL, /PREV, /RUNTIME |
| TSC                  | /AT, /BRIEF, /CONFIG, /FULL, /ID, /NEXT, /<br>OUT, /POOL, /PREV, /RUNTIME        |
| <b>TRACE Command</b> |                                                                                  |
| None                 | None                                                                             |

## 12.2. ACMSSNAP CLOSE Command

### ACMSSNAP CLOSE

ACMSSNAP CLOSE — Closes the current data snapshot file.

## Format

ACMSSNAP> CLOSE

## Privileges Required

None.

## Parameters

None.

## Qualifiers

None.

## Notes

Only one snapshot file can be open at a time.

## Examples

```
ACMSSNAP> CLOSE
```

This command closes the current data snapshot file.

# 12.3. ACMSSNAP EXIT Command

## ACMSSNAP EXIT

ACMSSNAP EXIT — Ends the current ACMSSNAP session.

## Format

ACMSSNAP> EXIT

## Privileges Required

None.

## Parameters

None.

## Qualifiers

None.

## Notes

This command ends the current ACMSSNAP session and returns control to DCL. It is equivalent to the QUIT command.

## Examples

```
ACMSSNAP> EXIT
```

This command ends the current ACMSSNAP session.

## 12.4. ACMSSNAP HELP Command

### ACMSSNAP HELP

ACMSSNAP HELP — Displays help information about the ACMS Remote Manager Data Snapshot Utility (ACMSSNAP) and its commands.

#### Format

```
ACMSSNAP> HELP
```

#### Privileges Required

None.

#### Parameters

None.

#### Qualifiers

None.

#### Notes

Online help is available for each ACMSSNAP command. Each help topic summarizes the valid syntax, abbreviations, parameters, and qualifiers for a particular command and also indicates all default and required values.

For a comprehensive list of ACMS utilities that offer online help or for further instructions on how to invoke help, see ACMS Help.

#### Examples

```
ACMSSNAP> HELP
```

This command invokes online help for the ACMSSNAP utility and displays a list of available topics.

## 12.5. ACMSSNAP NEXT Command

### ACMSSNAP NEXT

ACMSSNAP NEXT — Reads the next sequence of snapshot records.

#### Format

```
ACMSSNAP> NEXT [number]
```

#### Privileges Required

None.



## Parameters

number

A numeric value that indicates the number of records to be read. If a value is not specified, the default value of 1 record is used.

## Qualifiers

None.

## Notes

Use the NEXT command to move forward incrementally in a data snapshot file. When the NEXT command is issued, the ACMSSNAP utility reads the next record or series of records from the currently open snapshot file in chronological order. If a number is not specified with this command, NEXT moves forward one record at a time.

Note that the NEXT and PREV commands are not intended to be the primary means of navigation through a data snapshot file. Use the ACMSSNAP SHOW/AT command to first identify an approximate timeframe for the ACMS activity that you want to view. Then use the NEXT or PREV command to move forward or backward incrementally from that timeframe.

If tracing is turned on (TRACE command), header information is displayed for each record read.

## Examples

```
ACMSSNAP> NEXT 10
```

This command reads the next 10 records in the data snapshot file. These records overlay any previous records for this entity and class.

# 12.6. ACMSSNAP OPEN Command

## ACMSSNAP OPEN

ACMSSNAP OPEN — Opens the specified data snapshot file.

### Format

```
ACMSSNAP> OPEN file-name [/qualifiers]
```

| Command Qualifier | Default                                                         |
|-------------------|-----------------------------------------------------------------|
| /AT=time          | None                                                            |
| /CP_SLOTS=value   | The value of ACMS \$MGMT_SNAP_CP_SLOTS, or if not defined, 3.   |
| /MAX_AGENTS=value | The value of ACMS \$MGMT_SNAP_MAX_AGENTS, or if not defined, 2. |
| /MAX_APPLS=value  | The value of ACMS \$MGMT_SNAP_CP_SLOTS, or if not defined, 10.  |

| Command Qualifier | Default |
|-------------------|---------|
| /SUMMARY          | None    |

## Privileges Required

None.

## Parameters

file-name

This required parameter specifies an OpenVMS file specification or logical that indicates the name and location of the data snapshot file.

## Qualifiers

/AT=time

This qualifier moves through the open data snapshot file to the first record equal to or greater than the specified time. The format of time is *DD-MMMYY: hh:mm:ss.nn*. Partial dates and times (for example, 10-OCT or 09:00) are supported.

/CP\_SLOTS=value

This qualifier reserves space for CP records in a statically-sized internal table. CP records are stored in the table by process name. These records are not removed from the table until the snapshot file is closed. If there is insufficient space in the table, data for subsequent CP processes is discarded. (A warning message is issued if the CP table becomes full and TRACE is turned on). Specifying this qualifier overrides the value of the logical name `ACMS$MGMT_SNAP_CP_SLOTS`, if defined. The default value is 3.

/MAX\_AGENTS=value

This qualifier determines the number of different AGENT processes that can be read while the file is open. AGENT data is stored internally in a statically sized table, with one row for each unique AGENT process name found. If there is insufficient space in the table to hold all the AGENT records in the file, AGENT records are discarded. This qualifier overrides the `ACMS$MGMT_SNAP_MAX_AGENTS` logical name, which is an alternative way of specifying this value. Specifying this qualifier overrides the value of the logical name `ACMS$MGMT_SNAP_MAX_AGENTS`, if defined. The default value is 2.

/MAX\_APPLS=value

This qualifier reserves space for EXC records in a statically-sized internal table. EXC records are stored in the table by application name. These records are not removed from the table until the snapshot file is closed. If there is insufficient space in the table, data for subsequent EXC processes is discarded. (A warning message is issued if the EXC table becomes full and TRACE is turned on). Specifying this qualifier overrides the value of the logical name `ACMS$MGMT_SNAP_MAX_APPL`, if defined. The default value is 10.

/SUMMARY

This qualifier scans the entire data snapshot file and displays a summary report that shows the total number of records written (per entity, class, and file) as well as the time when the first and last record was written (per entity).

## Notes

Data snapshot files are RMS indexed files. You can open a snapshot file with the ACMSSNAP utility even if it is currently being written to by an ACMS Remote Manager process.

## Examples

```
ACMSSNAP> OPEN ACMS$MGMT_SNAPSHOT /SUMMARY /CP_SLOTS=10 /MAX_APPL=5
ACMS Remote Management -- Snapshot utility
  Compiling summary statics ...
```

| Entity # | Recs  | First Record           | Last Record            | All  | Id | Cfg | Rt |
|----------|-------|------------------------|------------------------|------|----|-----|----|
| Pool     | Error |                        |                        |      |    |     |    |
| acc      | 42    | 7-JUN-2001 14:00:56.69 | 7-JUN-2001 14:21:32.19 | 42   | 0  | 0   | 0  |
| 0        | 0     |                        |                        |      |    |     |    |
| tsc      | 42    | 7-JUN-2001 14:00:56.69 | 7-JUN-2001 14:21:32.19 | 42   | 0  | 0   | 0  |
| 0        | 0     |                        |                        |      |    |     |    |
| qti      | 0     |                        |                        | 0    | 0  | 0   | 0  |
| 0        | 0     |                        |                        |      |    |     |    |
| cp       | 184   | 7-JUN-2001 14:00:56.69 | 7-JUN-2001 14:21:32.19 | 184  | 0  | 0   | 0  |
| 0        | 0     |                        |                        |      |    |     |    |
| exc      | 204   | 7-JUN-2001 14:01:28.01 | 7-JUN-2001 14:21:32.19 | 204  | 0  | 0   | 0  |
| 0        | 0     |                        |                        |      |    |     |    |
| server   | 6496  | 7-JUN-2001 14:01:28.01 | 7-JUN-2001 14:21:32.19 | 6496 | 0  | 0   | 0  |
| 0        | 0     |                        |                        |      |    |     |    |
| group    | 3032  | 7-JUN-2001 14:01:28.01 | 7-JUN-2001 14:21:32.19 | 3032 | 0  | 0   | 0  |
| 0        | 0     |                        |                        |      |    |     |    |
| mgr      | 0     |                        |                        | 0    | 0  | 0   | 0  |
| 0        | 0     |                        |                        |      |    |     |    |

10000 Records Read

MAX\_APPL = 10 (use /MAX\_APPL on OPEN or define ACMS\$MGMT\_SNAP\_MAX\_APPL to change)

CP\_SLOTS = 10 (use /CP\_SLOTS on OPEN or define ACMS\$MGMT\_SNAP\_CP\_SLOTS to change)

This command opens the data snapshot file referenced by the ACMS\$MGMT\_SNAPSHOT logical, scans all the records, and displays a summary report. The CP\_SLOTS and MAX\_APPLS values are explicitly set.

## 12.7. ACMSSNAP PREV Command

### ACMSSNAP PREV

ACMSSNAP PREV — Scans the previous sequence of snapshot records.

#### Format

```
ACMSSNAP> PREV [number]
```

#### Privileges Required

None.

## Parameters

number

A numeric value that indicates the number of records to be read. If a value is not specified, the default value of 1 record is used.

## Qualifiers

None.

## Notes

Use the PREV command to move backward incrementally in a data snapshot file. When the PREV command is issued, the ACMSSNAP utility reads the previous record or series of records from the currently open snapshot file in reverse chronological order. If a number is not specified with this command, PREV moves backward one record at a time.

Note that the NEXT and PREV commands are not intended to be the primary means of navigation through a data snapshot file. Use the SHOW/AT=date-time command to first identify an approximate timeframe for the ACMS activity that you want to view. Then use the NEXT or PREV command to move forward or backward incrementally from that timeframe.

If tracing is turned on (TRACE command), header information is displayed for each record read.

## Examples

```
ACMSSNAP> PREV 10
```

This command scans and reads the previous 10 data snapshot records. These records overlay any previous records for this entity and class.

# 12.8. ACMSSNAP QUIT Command

## ACMSSNAP QUIT

ACMSSNAP QUIT — Ends the current ACMSSNAP session.

### Format

```
ACMSSNAP> QUIT
```

### Privileges Required

None.

### Parameters

None.

### Qualifiers

None.

## Notes

This command ends the current ACMSSNAP session and returns control to DCL. It is equivalent to the EXIT command.

## Examples

```
ACMSSNAP> QUIT
```

This command ends the current ACMSSNAP session.

# 12.9. ACMSSNAP RESET Command

## ACMSSNAP RESET

ACMSSNAP RESET — Clears the local memory tables.

### Format

```
ACMSSNAP> RESET [/qualifiers]
```

| Command Qualifier | Default |
|-------------------|---------|
| /ALL              | None    |

### Privileges Required

None.

### Parameters

None.

### Qualifiers

/ALL

This qualifier instructs the ACMSSNAP utility to place the file pointer at the beginning of the data snapshot file. If this qualifier is not specified, the local memory tables are cleared; however, the file pointer remains at the current position within the data snapshot file.

## Notes

Use the RESET command to remove all data snapshot records from internal data tables and clear the local memory buffer.

Specifying the /ALL qualifier is equivalent to closing and reopening the data snapshot file; the position marker is moved to the beginning of the data snapshot file. Without the /ALL qualifier, the internal tables are cleared, but the location of the position marker is not changed.

## Examples

```
ACMSSNAP> RESET /ALL
```

This command clears the local buffer of all data snapshot records and places the position marker at the beginning of the data snapshot file.

## 12.10. ACMSSNAP SHOW Command

### ACMSSNAP SHOW

ACMSSNAP SHOW — Locates and displays information from one or more data snapshot records.

#### Format

ACMSSNAP> SHOW entity [/qualifiers]

| Command Qualifier      | Default                                                                                         |
|------------------------|-------------------------------------------------------------------------------------------------|
| /APPL=application-name | None. Valid for EXC, SERVER, and Task Group only.                                               |
| /AT=time               | None                                                                                            |
| /[BRIEF,FULL]          | /FULL if no class qualifier (/CONFIG, /ID, /POOL, or /RUNTIME) is specified. Otherwise, /BRIEF. |
| /[class-name]          | * (all)                                                                                         |
| /GROUP=group-name      | Valid for Task Group only.                                                                      |
| /NEXT=value            | None                                                                                            |
| /OUT=file-name         | None                                                                                            |
| /PREV=value            | None                                                                                            |
| /SERVER=server-name    | Valid for Server only.                                                                          |

#### Privileges Required

None.

#### Parameters

entity

This parameter can be one of the following ACMS entities: ACC, AGENT, CP, EXC, GROUP, QTI, SERVER, or TSC.

#### Qualifiers

/APPL=application-name

This qualifier specifies the application for which you want to view information. This qualifier is only valid when specified with the EXC, SERVER, or GROUP entity.

/AT=time

This qualifier moves through the available data snapshot records and displays the first record equal to or greater than the specified time. The format of time is *DD-MMM-YY:hh:mm:ss.nn*. Partial dates and times (for example, 10-OCT or 09:00) are supported.

/[BRIEF,FULL]

This qualifier causes either summary (/BRIEF) or detailed (/FULL) information to be displayed.

`/[CONFIG, ID, POOL, RUNTIME]`

This qualifier causes data for the class to be displayed. If no class qualifier is specified, this qualifier is ignored and all details are displayed (equivalent to `/FULL`).

`/GROUP=group-name`

This qualifier specifies the ACMS task group for which you want to view information. Wildcard matching is performed on the name provided. This qualifier is only valid when specified with the `GROUP` entity.

`/NEXT=value`

Use this qualifier to display the specified number of records (in chronological order) for an entity. Data is displayed for each record found. If `/FULL` is not specified, a timestamp that indicates when the record was created is also displayed. A value is required with this qualifier.

`/OUT=file-name`

This qualifier causes output to be written to the specified file. If this qualifier is not specified, output is displayed to the terminal (`SYSS$OUTPUT`).

`/PREV=value`

Use this qualifier to display the specified number of records (in reverse chronological order) for an entity. Data is displayed for each record found. If `/FULL` is not specified, a timestamp that indicates when the record was created is also displayed. A value is required with this qualifier.

`/SERVER=server-name`

This qualifier specifies the ACMS procedure server for which you want to view information. Wildcard matching is performed on the name provided. This qualifier is only valid when specified with the `SERVER` entity.

## Notes

The data shown for each entity parallels the format of the equivalent `ACMSMGR` command with the following exceptions:

- A timestamp is appended within square brackets to the output of `/BRIEF` displays. This is provided as a navigational aid.
- The node name is derived from the translation of the `UCX$INET_HOST` logical on the system the snapshot file was created. In `ACMSMGR`, the node name is taken from whatever was specified by the client when the `ACMSMGR` command was issued (such as from the `/NODE` qualifier or from the `ACMS$MGMT_SERVER_NODE` logical).

Data is written to snapshot files based on entries in the `Collection` table. As a result, only specific classes of information for a given entity may have been stored. Show commands for entities and classes that were not stored may display their default collection values along with a state value of `disabled`. The storage state for the collection row must be enabled for the actual data to be stored.

The `/AT` qualifier is intended to be the initial means of navigation by locating a specific entity record for a point in time. The `ACMSNAP` utility uses the date given with the `/AT` qualifier and reads either backwards or forwards through the file until it finds a record for the specified entity. If the timestamp of the record is greater than the one specified, the utility begins reading backwards through the file until it finds an entity record with a time stamp equal to or less than the one specified.

If end or beginning of file is reached first, the search ends and an end-of-file message is displayed. Otherwise, the requested data is displayed. The end result is that when the command completes, a record is shown which is either at the exact time requested, or is the record just before or just after the time requested. You can then use the /NEXT or /PREV qualifier to navigate chronologically through adjacent records.

Special timestamps are used to deal with beginning and end of file conditions. If the beginning of file is reached, the current timestamp is forced to be NULL (17-NOV-1958 00:00:00.00). If the end of file is reached, the current timestamp is forced to be 17-NOV-3000 00:00:00.00. To recover from these situations, a single NEXT or PREV command will read either the first or last record in the file.

## Examples

- ACMSSNAP> SHOW ACC /RUNTIME /AT="7-JUN-2001 14:21"

```
ACMS Remote Management -- Snapshot utility
      Runtime  DECnet  ---- Users ---- --Applications- Application
Node    Class    Object  Current Maximum Current Maximum Starts
-----
sparks  enabled  started 97      100    5       5       5 [7-
JUN-2001-14:20:31.98]
```

This command displays ACC runtime information for the record written on June 7, 2001 at 14:20:31.98.

- ACMSSNAP> SHOW ACC /POOL /FULL

```
ACMS Remote Management -- Snapshot utility
=====
Node          POOL
-----
sparks        Pool Class Collection State      enabled
MSS Gauge                    Current   Max      Time
-----
14:19:12.45   MSS Objects                1859    1881    7-JUN-2001
MSS Maxbuf Message Counters          Current      Time
-----
MSS Msg Size    0 to 1024 bytes          13927
MSS Msg Size   1025 to 2048 bytes          94
MSS Msg Size   2049 to 4096 bytes         15
MSS Msg Size   4097 to 8192 bytes         41
MSS Msg Size   8193 to 16384 bytes        0
MSS Msg Size  16385 to 32768 bytes  0
MSS Msg Size  32769 to 65536 bytes  0
MSS Message Counter Overflow Resets  0
(null)
MSS Process Pool          Pct  Time
-----
Pool Size (bytes)          524288
Current Free (bytes)       516688 (98%)
Minimum Free (bytes)       515664 (98%) 7-
JUN-2001 14:18:16.00
Largest Current Free
Block (bytes)              65536
```



```

          Minimum Largest Free
          Block (bytes)                65536          7-
JUN-2001 14:20:56.00
          Allocation Failures          0
          Garbage Collections          0
          MSS Shared Pool                Pct  Time
          -----
          Pool Size (bytes)            33792000
          Current Free (bytes)         33624344  (99%)
          Minimum Free (bytes)        33620712  (99%)  7-
JUN-2001 14:14:25.98
          Largest Current Free
          Block (bytes)                65536
          Minimum Largest Free
          Block (bytes)                65536          7-
JUN-2001 14:20:56.00
          Allocation Failures          0
          Garbage Collections          0
          WS/TWS Pools (for all EXCs)  Current  Max
Time
-----
          TWS Pool Size Total (pagelets) 562800    562800    7-
JUN-2001 14:20:55.99
          TWSC Pool Size Total (pagelets) 22500     22500     7-
JUN-2001 14:20:55.99
          WS Pool Largest Used (bytes)   536       536       7-
JUN-2001 14:20:55.99
          WSC Pool Largest Used (bytes)  848       848       7-
JUN-2001 14:20:55.99
          TWS Pool Largest Used (bytes)  73728    73728    7-
JUN-2001 14:20:55.99
          TWSC Pool Largest Used (bytes) 1792      1792     7-
JUN-2001 14:20:55.99
          WS/TWS Pools (for all EXCs)    Current  Min
Time
-----
          WS Pool Minimum Free (bytes)   130536    130536    7-
JUN-2001 14:20:55.99
          WSC Pool Minimum Free (bytes)  64688     64688     7-
JUN-2001 14:20:55.99
          TWS Pool Minimum Free (bytes)  3809280   3809280   7-
JUN-2001 14:20:55.99
          TWSC Pool Minimum Free (bytes) 152704    152704    7-
JUN-2001 14:20:55.99

```

This command displays ACC pool information from the same record.

## 12.11. ACMSSNAP TRACE Command

### ACMSSNAP TRACE

ACMSSNAP TRACE — Toggles tracing information on and off.

## Format

ACMSSNAP> TRACE

## Privileges Required

None.

## Parameters

None.

## Qualifiers

None.

## Notes

The main function of tracing is to display the node, timestamp, entity, and class type for the record being read. Tracing also provides some warning information when the internal CP or EXC tables become full.

The TRACE command either turns tracing on or off, depending on the current state. A status message is displayed when the command is issued that indicates which action was performed.

## Examples

ACMSSNAP> TRACE

This command activates tracing for the current ACMSSNAP session.

# Appendix A. Remote Manager Logical Names

This appendix contains information about the Remote Manager logical names used by the Remote Manager server and the Remote Manager client (ACMSMGR utility).

## A.1. Remote Manager Server

The following list describes the logical names used by the Remote Manager server. If these logical names are present, they must be defined at a level that will be translated by the Remote Manager server. In general, these should be defined as system logicals.

- ACMS\$MGMT\_ALLOW\_PROXY\_ACCESS

If defined as 1 or TRUE, the Remote Manager will perform proxy authorization using the ACMSPROXY.DAT file. If not defined, only explicit (user name and password) authorization is allowed.

- ACMS\$MGMT\_CONFIG

File specification for the configuration file. If not defined, the default is SYSSYSROOT:[SYSEXE]ACMS\$MGMT\_CONFIG.ACM. The default file extension is .ACM.

- ACMS\$MGMT\_TEMP

Pointer to a directory that the Remote Manager server uses for writing and reading temporary command procedures used to modify the ACMS run-time system. If not defined when the Remote Manager server is started, the Remote Manager will define this as a system logical with a translation of SY\$MANAGER.

- ACMS\$MGMT\_LOG

File specification for the Remote Manager log. If not defined, the default is ACMS\$MGMT\_LOG.LOG in the default directory of the Remote Manager.

## A.2. Remote Manager Client (ACMSMGR Utility)

The following is a list of logical names used by the ACMSMGR utility:

- ACMS\$MGMT\_USER

Defines the user name for Remote Manager authentication and authorization. This logical name should not be defined if proxy access is being used. If ACMS\$MGMT\_USER is not defined, the ACMSMGR utility either creates a user name (during login) or searches for the credentials file for this user. This logical name can be overridden by using the /USER qualifier on ACMSMGR commands.

- ACMS\$MGMT\_SERVER\_NODE

Defines the fully or partially qualified TCP/IP node name. `ACMS$MGMT_SERVER_NODE` determines the nodes to which the `ACMSMGR` command is submitted. `ACMS$MGMT_SERVER_NODE` can be specified as a comma-separated list, in which case an attempt is made to execute the command on each node in the list serially. This logical name can be overridden by using the `/NODE` qualifier to `ACMSMGR` commands.

- `ACMS$MGMT_CREDS_DIR`

Defines the directory in which the `ACMSMGR` stores and looks for credentials files. Credentials files are created by the `ACMSMGR LOGIN` command and are specific to a process on a node. See Section 4.4.1.1 for more information.

# Appendix B. RPC Procedures and Corresponding Rights Identifiers

Table B.1 lists RPC procedures and their corresponding rights identifiers.

**Table B.1. RPC Procedures and Corresponding Rights Identifiers**

| Procedure                    | Rights Identifier |
|------------------------------|-------------------|
| ACMSMGMT_ADD_COLLECTION_1    | ACMS\$MGMT_WRITE  |
| ACMSMGMT_ADD_TRAP_1          | ACMS\$MGMT_OPER   |
| ACMSMGMT_DELETE_COLLECTION_1 | ACMS\$MGMT_WRITE  |
| ACMSMGMT_DELETE_TRAP_1       | ACMS\$MGMT_OPER   |
| ACMSMGMT_GET_ACC_1           | ACMS\$MGMT_READ   |
| ACMSMGMT_GET_MGR_STATUS_1    | ACMS\$MGMT_READ   |
| ACMSMGMT_GET_PARAM_1         | ACMS\$MGMT_READ   |
| ACMSMGMT_GET_QTI_1           | ACMS\$MGMT_READ   |
| ACMSMGMT_GET_TSC_1           | ACMS\$MGMT_READ   |
| ACMSMGMT_LIST_COLLECTIONS_1  | ACMS\$MGMT_READ   |
| ACMSMGMT_LIST_CP_1           | ACMS\$MGMT_READ   |
| ACMSMGMT_LIST_EXC_1          | ACMS\$MGMT_READ   |
| ACMSMGMT_LIST_INTERFACES_1   | ACMS\$MGMT_READ   |
| ACMSMGMT_LIST_LOG_1          | ACMS\$MGMT_READ   |
| ACMSMGMT_LIST_PROC_1         | ACMS\$MGMT_READ   |
| ACMSMGMT_LIST_SERVER_1       | ACMS\$MGMT_READ   |
| ACMSMGMT_LIST_TG_1           | ACMS\$MGMT_READ   |
| ACMSMGMT_LIST_TRAP_1         | ACMS\$MGMT_READ   |
| ACMSMGMT_LIST_USERS_1        | ACMS\$MGMT_READ   |
| ACMSMGMT_REPLACE_SERVER_1    | ACMS\$MGMT_OPER   |
| ACMSMGMT_RESET_LOG_1         | ACMS\$MGMT_WRITE  |
| ACMSMGMT_SET_ACC_1           | ACMS\$MGMT_OPER   |
| ACMSMGMT_SET_COLLECTION_1    | ACMS\$MGMT_WRITE  |
| ACMSMGMT_SET_EXC_1           | ACMS\$MGMT_OPER   |
| ACMSMGMT_SET_INTERFACE_1     | ACMS\$MGMT_WRITE  |
| ACMSMGMT_SET_PARAM_1         | ACMS\$MGMT_WRITE  |
| ACMSMGMT_SET_QTI_1           | ACMS\$MGMT_OPER   |
| ACMSMGMT_SET_SERVER_1        | ACMS\$MGMT_OPER   |
| ACMSMGMT_SET_TRAP_1          | ACMS\$MGMT_OPER   |
| ACMSMGMT_SET_TSC_1           | ACMS\$MGMT_OPER   |
| ACMSMGMT_START_ACC_1         | ACMS\$MGMT_OPER   |
| ACMSMGMT_START_EXC_1         | ACMS\$MGMT_OPER   |

---

| <b>Procedure</b>               | <b>Rights Identifier</b> |
|--------------------------------|--------------------------|
| ACMSMGMT_START_QTI_1           | ACMS\$MGMT_OPER          |
| ACMSMGMT_START_TRACE_MONITOR_1 | ACMS\$MGMT_OPER          |
| ACMSMGMT_START_TSC_1           | ACMS\$MGMT_OPER          |
| ACMSMGMT_STOP_1                | ACMS\$MGMT_OPER          |
| ACMSMGMT_STOP_ACC_1            | ACMS\$MGMT_OPER          |
| ACMSMGMT_STOP_EXC_1            | ACMS\$MGMT_OPER          |
| ACMSMGMT_STOP_QTI_1            | ACMS\$MGMT_OPER          |
| ACMSMGMT_STOP_TRACE_MONITOR_1  | ACMS\$MGMT_OPER          |
| ACMSMGMT_STOP_TSC_1            | ACMS\$MGMT_OPER          |

# Appendix C. RPC Procedures and Corresponding Rights Identifiers

This appendix contains the error messages related to the Remote Manager server process, as well as the ACMSMGR, ACMSCFG, and ACMSSNAP utilities.

## C.1. Server Messages

The following error messages pertain to the ACMS Remote Manager server process.

**Message:** 2MANY\_USERS, the maximum number of users has been reached

- **Explanation:** The user could not be logged in because the maximum number of concurrent users has been reached. This maximum is determined by the max\_logins parameter, which is a dynamic parameter (that is, it can be changed dynamically).
- **User Action:** Either log some users out, or increase the value of the max\_logins parameter. You can use the ACMSMGR SHOW USERS command to determine which users are already logged in to the Remote Manager. Note that in order to issue that command or to increase the max\_logins parameter, you must be logged in.

**Message:** ACCTEXP, account is expired

- **Explanation:** This status is returned during user login if the account associated with the user name has expired.
- **User Action:** Either remove or modify the account expiration.

**Message:** ACMSPARFAIL, attempt to read ACMSPAR.ACM failed. See audit log for details.

- **Explanation:** This status is returned when the Remote Manager cannot access the ACMSPAR.ACM parameters file.
- **User Action:** Examine the Remote Manager log file (using ACMSMGR SHOW LOG) and correct the problem.

**Message:** AUTHUPDFAIL, attempt to update the OpenVMS Authorization file failed. See audit log for details.

- **Explanation:** This status is returned when the Remote Manager is unable to write to the SYSUAF during an attempt to update an OpenVMS system parameter.
- **User Action:** Examine the Remote Manager log file (using ACMSMGR SHOW LOG) and correct the problem.

**Message:** BADDAY, network access is prohibited for this day of week for this account

- **Explanation:** This status is returned during user login if the UAF record for this user does not allow network access on this day of the week. Day-of-week restrictions on network access are set by system administrators or security personnel.
- **User Action:** Either wait until an authorized day of the week to access the Remote Manager, or modify the network access portion of the UAF for this user.

**Message:** BADHOUR, network access is prohibited for this hour for this account

- **Explanation:** This status is returned during user login if the UAF record for this user does not allow network access during this time of day. Time-of-day restrictions on network access are set by system administrators or security personnel.
- **User Action:** Either wait until an authorized hour to access the Remote Manager, or modify the network access portion of the UAF for this user.

**Message:** CRED\$S\_DATA\_ERR, credentials file is corrupt

- **Explanation:** The credentials file for this user has been corrupted. The file has been opened, but the client process cannot parse the contents of the file.
- **User Action:** The user should log in to the Remote Manager again. This will create a new credentials file.

**Message:** DISUSER, account is disusered

- **Explanation:** This status is returned during user login if the account associated with the user name has the DISUSER flag set.
- **User Action:** Clear the DISUSER flag on the UAF record for the account.

**Message:** DUPLICATE\_ROW, table row exists

- **Explanation:** An attempt was made to add a row to either the Trap or the Collection table, but the row already exists.
- **User Action:** Either modify the existing row, or add a new row with unique data.

**Message:** ERRBOTHFLAGS, both current and active flags were set. They are mutually exclusive. No updates performed.

- **Explanation:** This status is returned when a request is made to modify Configuration data for an entity by setting both the `current_flag (/CURRENT)` and `active_flag (/ACTIVE)` parameters. These flags are mutually exclusive; the Remote Manager rejects the request.
- **User Action:** Resubmit the RPC call or ACMSMGR SET command setting only one flag per call or command.

**Message:** ERRSTOPSNP, attempt to stop snapshot thread failed. General internal error.

- **Explanation:** An attempt was made to stop a data snapshot thread by setting the `storage_state` parameter to `DISABLED` or deleting a row in the Collection table. The attempt failed due to a CMA exception.
- **User Action:** This is a non-recoverable error. Reissue the RPC call or ACMSMGR command. If the problem persists, restart the Remote Manager process.

**Message:** FLTRDBCORRUPT, the filter file database is corrupt.

- **Explanation:** This status is returned when the Remote Manager error filter database is non-readable.
- **User Action:** Shut down ACMS and the Remote Manager. Delete the file `SY$SYSTEM:ACMS $MGMT_ERROR_FILTER.DAT;*`, and restart ACMS and the Remote Manager. If you have



previously saved the contents of the error filter database (with ACMSMGR SAVE FILTER), you can restore the database with the following command:

```
$ ACMSMGR ADD FILTER /FILE=file-name
```

where *file-name* is a full OpenVMS file specification (node::device:[directory]file.ext) for the error filter file.

**Message:** FLTRDBFULL, the filter database is full

- **Explanation:** This status is returned while attempting to add an error message filter record to a database that is at capacity.
- **User Action:** Delete one or more error filter records using the ACMSMGR DELETE FILTER command.

**Message:** FLTRDBINIT, the filter file global section is not initialized

- **Explanation:** This status is returned while attempting to access the error filter database without the global section initialized.
- **User Action:** Report this error to your HP support representative.

**Message:** EVNT\_MBX\_FUL, event mailbox is full

- **Explanation:** This status code has not been implemented.
- **User Action:** No action is required.

**Message:**

- **Explanation:**
- **User Action:**

**Message:** FAIL, operation failed

- **Explanation:** The function requested could not be performed.
- **User Action:** The appropriate action depends on the function being called. In general, additional information is displayed by the ACMSMGR command in conjunction with this error code. That information should be more indicative of the reason for failure. If this status was returned by an RPC, the failure occurred in the Remote Manager process; a second-level error code is returned in the output record.

**Message:** INFO, operation completed with information message

- **Explanation:** The ACMS Remote Manager service completed without error but has logged an informational message. Informational messages are for debugging and auditing purposes.
- **User Action:** No action is required.

**Message:** INTERNALERR, an internal error has occurred. See audit log for details

- **Explanation:** A request was to update the runtime ACMS system, but an unexpected error was returned by the DCL manager subsystem.

- **User Action:** Examine the Remote Manager log for related informational messages. If the problem persists, restart the Remote Manager process.

**Message:** INV\_CLNTID, client id is invalid

- **Explanation:** A request was made to the Remote Manager with an invalid client id. The client id is a unique value assigned to each client and used to verify client authorization. If the client id is not known to the Remote Manager, it either belongs to an old log in that has expired and been purged, or it was never valid.
- **User Action:** The user should log in to the Remote Manager again.

**Message:** INVVAR, invalid variable value was provided

- **Explanation:** This status code is obsolete.
- **User Action:** No action required.

**Message:** LOGIN\_EXPIRED, login credentials have expired, please log in again

- **Explanation:** The credentials you used to log in to the Remote Manager have expired. Credentials are granted when the user logs in and are valid for a period of time equal to the value of the login\_creds\_lifetime parameter at the time of login. After that time, the credentials expire and must be re-created by logging in to the Remote Manager again.

Note that while proxy credentials also expire, they are automatically recreated at the end of the expiration period. Therefore, this status is never returned to proxy users.

- **User Action:** The user must log in to the Remote Manager again.

**Message:** MSGEXISTS, message already exists

- **Explanation:** An attempt was made to add an existing error message record to the filter database.
- **User Action:** No action required.

**Message:** NOACCFLTRDB, the filter database cannot be read or written

- **Explanation:** The memory address returned for error filter global section is not allowing read or write operations.
- **User Action:** Examine the OWNER and GROUP protections on the file SYS\$SYSTEM:ACMS \$MGMT\_ERROR\_FILTER.DAT. Check the user accounts for the related ACMS Remote Manager processes to verify that they have READ and WRITE access to the file. The file owner and the ACMS accounts should be in the same group. All members of this group should have read and write access to the file.

**Message:** NOAPPLQUAL, /APPL qualifier missing

- **Explanation:** The command ACMSMGR SET EXC requires that you use an /APPL qualifier to specify the application for which stored values are being set. If the /APPL qualifier is missing, the error NOAPPLQUAL will be returned.
- **User Action:** Re-enter the ACMSMGR SET EXC command with a /APPL qualifier.

**Message:** NO\_CREDS\_FILE, credentials file not found

- **Explanation:** The credentials file for the user either could not be found or could not be opened by the client process. The credentials file is created when a user explicitly logs in to the Remote Manager (that is, when the user supplies a user name and password). A separate credentials file is created for each node to which a particular process logs in. The logical name ACMS\$MGMT\_CREDS\_DIR is used to point to the directory containing credentials files.
- **User Action:** Verify that the ACMS\$MGMT\_CREDS\_DIR logical is pointing to a valid disk and directory in which a credentials file has been created; verify that the process has read access to the files in the directory. If necessary, the process may have to log in to the Remote Manager again to create a new credentials file.

**Message:** NOINTERVAL, storage interval not supplied. Cannot enable a thread without an interval. Resubmit with an interval.

- **Explanation:** An API call was made to either the acms\$mgmt\_set\_collection\_2 or acms\$mgmt\_add\_collection\_2 function, but no value was specified for the storage interval.
- **User Action:** Reissue the call making sure that a valid storage\_interval is specified prior to setting the storage\_state to ENABLED.

**Message:** NOMEM, memory allocation failed

- **Explanation:** An internal memory allocation by the Remote Manager failed. This can occur during a request for data, a call to add a record to a table, or during server initialization while it is loading initial configuration information. In the first two instances, the Remote Manager continues to run; in the third, the Remote Manager exits.
- **User Action:** Increase the amount of memory available to the Remote Manager. If the problem is due to insufficient physical or virtual memory, try allocating more page or swap space. If physical and virtual memory are not exhausted, try increasing the memory quotas for the account in which the Remote Manager is running. Be sure to check SYSGEN PQL quotas to ensure that the quotas you grant to the Remote Manager are allowed by the system.

After making more memory available to the Remote Manager, you must restart the Remote Manager process.

**Message:** NOMORE\_DATA, no more data is available

- **Explanation:** There is no more data that satisfies the query. This message is provided on list RPCs that can return more than one buffer of data. If a list RPC is called and this status is not returned, then more data is available that satisfies the query criteria. If this status is returned, then there is no more data to retrieve for this query.
- **User Action:** No action is required. The query is complete.

**Message:** NOMSGINTBL, message not in filter database

- **Explanation:** An attempt was made to access an error message code that does not currently exist in the error filter database.
- **User Action:** Verify that the error message code is correct and that it exists in the filter database. To display the error message codes currently being filtered, use the ACMSMGR SHOW FILTER command.

**Message:** NONETACCESS, network access is prohibited for this account

- **Explanation:** This status is returned during user login if the account associated with the user name has not been granted network access. Network access is required, even if the user is logged in to same node on which the Remote Manager is running.
- **User Action:** Grant network access to the account.

**Message:** NO\_NODELOGICAL, cannot translate logical UCX\$INET\_HOST to get node name

- **Explanation:** The logical name UCX\$INET\_HOST could not be translated by the client process. This logical is used to determine the current host name, which is used during client authentication. It is defined by the UCX or TCP/IP layered product when it is started. If this logical is not defined, UCX or TCP/IP is not started; either a different TCP/IP networking package is being used, or something has gone wrong with the logical name.
- **User Action:** Verify that the UCX or TCP/IP layered product is started. If it is not, start it and then reissue the command. If it is started, contact your system administrator to determine why the logical is not defined.

**Message:** NOPROXY, proxy access is not enabled

- **Explanation:** This status is returned when a user attempts to access a Remote Manager function without explicitly logging in, and proxy access has not been enabled on the Remote Manager node. Proxy access is enabled on the node by defining the system logical ACMS\$MGMT\_ALLOW\_PROXY\_ACCESS to be TRUE, true, T, t, Y, y, or 1. The translation of this logical is cached by the Remote Manager when the RPC thread is started.
- **User Action:** If proxy access is not supposed to be enabled, then there is no action to perform. If proxy access is to be allowed, define the ACMS\$MGMT\_ALLOW\_PROXY\_ACCESS system logical, with a translation value of TRUE, true, T,t, Y, y or 1. Then restart the Remote Manager and resubmit the RPC.

**Message:** NOREINIT, filter file cannot be re-initialized

- **Explanation:** The Remote Manager attempted to reinitialize the filter database. This is result of an internal consistency check that failed. The error should not have occurred.
- **User Action:** Report this error to your HP support representative.

**Message:** NORIGHT, user does not hold the proper rights identifier

- **Explanation:** Access to Remote Manager functions is restricted by a set of rights identifiers; the account being used to access the function must have the appropriate rights identifier. If this status code is returned, the account does not have the appropriate rights identifier.
- **User Action:** Grant the appropriate rights identifier to the user's account. If a proxy account is being used, the rights identifier must be granted to the proxy account.

**Message:** NOSTOP, interface cannot be used to stop itself

- **Explanation:** An attempt was made to stop an interface by using that interface. The Remote Manager does not allow either the RPC or the SNMP interface to be used to stop themselves.
- **User Action:** If you need to stop the RPC interface and cannot use the ACMSMGR command, stop the Remote Manager either by using the DCL command STOP/ID or by using the UCX\$SNMP\_REQUEST (or TCPIP\$SNMP\_REQUEST) program. These programs are located in SYS\$SYSTEM; the OID to use is 1.3.6.1.4.1.36.2.18.48.4.1.3.1.

To stop the SNMP interface, you must use the ACMSMGR SET INTERFACE command, or you must stop the Remote Manager (using either the ACMSMGR STOP command or the DCL command STOP/ID).

**Message:** NOSUCHAPPL, /APPL application does not exist

- **Explanation:** The command ACMSMGR SET EXC requires that you use an /APPL qualifier to specify the application for which stored values are being set. NOSUCHAPPL is returned if the application you specify is not active.
- **User Action:** Re-enter the ACMSMGR SET EXC command specifying an active application in the /APPL qualifier.

**Message:** NOTENABLED, cannot disable storage if it is not enabled

- **Explanation:** An attempt was made to set the storage\_state for a Collection record to DISABLED when it already was disabled. No action was performed by the Remote Manager.
- **User Action:** No action is required.

**Message:** NOTFILTERFILE, the file is not an error filter text file

- **Explanation:** This status is returned when the file specified in the ACMSMGR ADD FILTER/FILER command does not meet the format requirements for an error filter file.
- **User Action:** Verify that the file specification is correct. If the specification is correct, review ACMSMGR online help for details about the formatting requirements for an error filter file. The first line of the file must contain the string %%ACMS Filter File V1.00. If it does not, the Remote Manager will not consider it a valid error filter file.

**Message:** NOT\_FOUND, record not found

- **Explanation:** An attempt was made to delete a row from the Collection table, but that row does not exist.
- **User Action:** Modify the request to include the proper identification information for the row (entity type, class, and name).

**Message:** NOT\_MAPPED, ACMSMGMT global section is not available on node <nodename>

- **Explanation:** This status code is returned if a Remote Manager function was requested that requires access to the ACMSMGMT global section, but the global section does not exist. The global section is created by the ACMS ACC during system startup. This status code indicates that the ACMS ACC is not running or that it has not yet created the global section.
- **User Action:** Start the ACMS run-time system in order to create the global section. The ACMS run-time system can be started by using either the ACMSMGR START SYSTEM command or the ACMS/START SYSTEM command.

**Message:** NOT\_VALID, entity data is stale, please resubmit query or wait until later

- **Explanation:** The entity record in the global section is not valid. If this status code is returned, it means that the entity has never been started on the Remote Manager node. If the entity had been running at one time but no longer is, a severity level of WARN is returned and the record\_state is set to INACTIVE.

- **User Action:** No action is required. However, if the entity is started on the Remote Manager node, the data will become available.

**Message:** NO\_UPD\_CLS, class cannot be modified

- **Explanation:** An attempt was made to add, delete, or modify a Collection table record for the Id or Config class. These records cannot be modified.
- **User Action:** No action is required. There is no way to modify the default collection records for the Id or Config classes.

**Message:** PROXY\_FAILED, proxy access attempt failed

- **Explanation:** An attempt to verify proxy information for this client failed. A more specific message indicating why the proxy failed is written to the Remote Manager log. Reasons for proxy authentication failure include:
  - No proxy record is in the ACMSPROXY.DAT file.
  - The proxy account is disusered.
  - There is a problem with the network access for the account (does not have network access allowed, is outside of the allowed network access days or times).
  - The proxy account has expired.
  - An internal error occurred during processing.
- **User Action:** First check the Remote Manager log for any additional information related to the login attempt. Then verify that none of the conditions listed are preventing the login from succeeding.

**Message:** PWDEXP, password has expired

- **Explanation:** The password entered by the user has expired in the UAF on the server node.
- **User Action:** The user must either change the password or have it unexpired by a system or security administrator.

**Message:** PWDFAIL, invalid password

- **Explanation:** The password entered for the user during user login does not match the one stored in the UAF for this user on the server node.
- **User Action:** Resubmit the login request for the user with the correct password.

**Message:** SECCHKFAIL, security check failed. You do not hold the ACMS\$MGMT\_ SYSUPD rights identifier

- **Explanation:** A request was made to modify one or more OpenVMS SYSGEN parameters with the Remote Manager; however, the user does not have the proper rights identifier. The request was denied.
- **User Action:** Ask the ACMS system manager to grant the user account the ACMS \$MGMT\_ SYSUPD rights identifier.

**Message:** SNPRUNNING, failure creating timer thread entry. Thread already running?

- **Explanation:** A request was made to set the storage\_state for a Collection record to ENABLED; however, an internal error was raised.
- **User Action:** Examine the Remote Manager log for additional messages that describe the source of the problem. Reissue the command. If the problem persists, try deleting and adding the Collection record. If the problem remains, restart the Remote Manger process.

**Message:** SUCCESS, operation completed

- **Explanation:** The ACMS Remote Manager service completed without error.
- **User Action:** No action is required.

**Message:** TABLE\_FULL, collection table is full. Non dynamic parameter total\_entity\_slots controls size

- **Explanation:** An attempt was made to add a row to the Collection table, but there are no empty slots. The maximum number of rows in the Collection table is determined by the nondynamic parameter total\_entity\_slots.
- **User Action:** To make the table bigger, modify this parameter in the configuration file (using the ACMSCFG command), and restart the ACMS run-time system. The Remote Manager can be left running.

Alternatively, delete unneeded rows from the Collection table.

**Message:** THREADRUNNING, inconsistent state detected. Snapshot state is disabled but thread is running! Cannot enable running thread

- **Explanation:** A request was made to set the storage\_state for a Collection record to ENABLED. While processing the row, the Remote Manager discovered that a snapshot thread had already been assigned to this record. This condition is most likely due to a previous, unsuccessful attempt to end a snapshot operation.
- **User Action:** Examine the Remote Manager log for additional messages that describe the source of the problem. Reissue the command. If the problem persists, try deleting and adding the Collection record. If the problem remains, restart the Remote Manger process.

**Message:** VRSNMISMAT, filter file version mismatch

- **Explanation:** The Remote Manager error filter file may be corrupted, or the format may have changed in this version of ACMS.
- **User Action:** Shut down ACMS and the Remote Manager. Delete the file SYSS\$SYSTEM:ACMS \$MGMT\_ERROR\_FILTER.DAT;\*, and restart ACMS and the Remote Manager. If you have previously saved the contents of the error filter database (with ACM\$MGR SAVE FILTER), you can restore the database with the following command:

```
$ ACM$MGR ADD FILTER /FILE=file-name
```

where *file-name* is a full OpenVMS file specification (node::device:[directory]file.ext) for the error filter file.

**Message:** WARN, operation completed with warning, Not all operations completed successfully

- **Explanation:** The ACMS Remote Manager service did not complete successfully; some of the actions requested could not be completed. This status is returned in the following situations:

- Multiple fields were specified on an update function, at least one of which failed. For example, a call may have been made to the set parameters function (`acmsmgmt_set_param_1`) to update more than one parameter, and one of the values specified was invalid. For these functions, a list of fields is returned with status codes for each field.
- A call to start or stop an ACMS process was executed, and a warning was returned. Starting or stopping ACMS processes is performed by ACMS OPER, which may return warning messages. In this case, a set of messages is returned describing the cause for the warning.
- A call to display ACMS process information was made, and old (stale) data was returned. This can occur when an ACMS process is no longer running, and a show function requests data for that process. For instance, if the TSC was running and then had been stopped, and the `acmsmgmt_get_tsc_1` function is called, the tsc record is returned with WARN status.
- **User Action:** No action is required; however, the `record_state` field of any record returned should be checked. The Remote Manager flags old data with a `record_state` of `MGMT$K_INACTIVE`.

If this status is returned as the result of an ACMSMGR command, old (inactive) records are flagged with an asterisk (\*) preceding the node name.

**Message:** `WRONG_NODE`, current node does not match node in credentials file!

- **Explanation:** The node name stored in the credentials file does not match the node name on which the current process created it. Either the file is corrupt, or it has been tampered with.
- **User Action:** The user should log in to the Remote Manager again. This will create a new credentials file.

**Message:** `WRONG_PID`, current pid does not match pid in credentials file!

- **Explanation:** The PID stored in the credentials file does not match that of the current process. Either the file is corrupt, or it has been tampered with.
- **User Action:** The user should log in to the Remote Manager again. This will create a new credentials file.

**Message:** `XLATE_FAILED`, an attempt to translate a symbolic error name failed

- **Explanation:** An attempt was made to add an error filter record using the symbolic name for the error message. The translation of the symbolic name to its hexadecimal value failed.
- **User Action:** Verify that you have specified the symbolic name correctly. If the problem persists, try entering the record using the hexadecimal value of the error message that you want to filter.

## C.2. ACMSMGR Messages

The following error messages pertain to the ACMSMGR process.

**Message:** `2MANYCLASSES`, too many class qualifiers were specified.

- **Explanation:** Each ACMSMGR command allows either one class or all classes to be displayed at the same time. To display all classes, do not include a class qualifier with the command. To display a particular class, include that qualifier with the command. You cannot specify more than one class qualifier with a given command.



- **User Action:** Modify the command to include a maximum of one class qualifier, and resubmit the command. To learn more about the valid class qualifiers for a given command verb and object, use the ACMSMGR HELP command.

**Message:** ACTUPDINV, /active was specified for <field>, but this value is not dynamic. No update was performed

- **Explanation:** An attempt was made to modify Configuration class data for an entity using ACMSMGR SET <entity> /ACTIVE command; however, one of the specified variables does not have an active value.
- **User Action:** Reissue the command either without the /ACTIVE qualifier or with only variables that have an active value. For a list of variables and their valid values, see the ACMSMGR online help.

**Message:** BADTIME, invalid time <time>

- **Explanation:** The time specification provided for the command qualifier could not be parsed. Time specifications can include date and time, date only or time only. The date and time should be specified as a quoted string in the format DDMMYYYY HH:MM:SS.hh. Partial strings are accepted (for example, "1NOV" or "10:00").
- **User Action:** Modify the command to include a valid time specification. To learn more about valid time values, use the ACMSMGR HELP command.

**Message:** BADVALUE, invalid qualifier, cannot interpret value <value>

- **Explanation:** The value provided for a command qualifier is invalid. It is either out of the range of acceptable values or is an invalid type.
- **User Action:** Modify the command qualifier to include a valid value. To learn more about valid values for a given qualifier, use the ACMSMGR HELP command.

**Message:** CREDSFOUND, credentials for node <node> found, they will be used

- **Explanation:** This message is obsolete.
- **User Action:** No action is required.

**Message:** ENCRYPTFAIL, encryption routine failure on <username>

- **Explanation:** An attempt to encrypt the user name indicated for client authentication failed.
- **User Action:** Make sure the user name is correct and reenter it.

**Message:** END\_TOO\_SOON, end time must be greater than begin time

- **Explanation:** While adding or modifying a row in the Collection table, an attempt was made to specify a storage\_end\_time earlier than the current storage\_begin\_time.
- **User Action:** Reissue the command, ensuring that storage\_end\_time is later than the storage\_begin\_time; or omit storage\_end\_time or storage\_begin\_time to accept the default value.

**Message:** FILEOPENERR, could not open file <filename> for write

- **Explanation:** This message is displayed when the /OUT qualifier to ACMSMGR command specifies an invalid or inaccessible file specification. The reason could be an invalid disk or device

name, an incorrect logical name in the file specification, insufficient privileges for writing to the directory or file, or a full device.

- **User Action:** Ensure that the client process can access the directory and file in the file specification, and resubmit the command.

**Message:** HOSTNAMEFAIL, can't translate UCX\$INET\_HOST name, aborting...

- **Explanation:** The logical name UCX\$INET\_HOST could not be translated by the client process. This logical is used to determine the current host name, which is used during client authentication. The logical is defined by the UCX or TCP/IP layered product when it is started. If the logical is not defined, either UCX or TCP/IP is not started, a different TCP/IP networking package is being used, or something has gone wrong with the logical name.
- **User Action:** Verify that the UCX or TCP/IP layered product is started. If it is not, start it and then reissue the command. If it is started, contact your system administrator to determine why the logical is not defined.

**Message:** INACTDATA, some or all data is old and may not accurately reflect the running system

- **Explanation:** The data being displayed may contain information about processes that are no longer running. Old, or stale, data is displayed only if the /ALL qualifier was included with the command. The old records are flagged with an asterisk (\*) in the first character of the node name.
- **User Action:** No action is required. Remove the /ALL qualifier if you do not want to see old data.

**Message:** LOGIN\_FAIL, login failed

- **Explanation:** The attempt to log in failed. The reason might be an invalid user name or password. The Remote Manager log will contain more information about the reason for failure.
- **User Action:** Consult the Remote Manager log on the target node for more information about the failure (using the ACMSMGR SHOW LOG command). Correct the problem and resubmit the login request.

**Message:** NAME2BIG, username is too long, please reenter

- **Explanation:** The user name specified exceeds the maximum allowed length of 12 characters.
- **User Action:** Modify the user name to be no longer than 12 characters and reenter it.

**Message:** NOCLIENTS, no clients created, cannot continue

- **Explanation:** No client attaches were successful. Previous messages will have been displayed indicating the particular reasons that the client attaches failed. Without attaching a client to a server, work can not be performed.
- **User Action:** Determine and remedy the reason for the client attach failures then resubmit the command.

**Message:** NOCLNT\_ATTACH, cannot create client for node <node-name>

- **Explanation:** An attempt to attach to the server on the node indicated in the command failed. If more than one server name was in the list to be processed, the next server will be tried. No further attempt will be made to submit commands to the node for which the attached client failed.

- **User Action:** Verify that the node name is correct and that the Remote Manager is running on the node indicated. In some networks, it may be necessary to use a fully qualified TCP/IP node name. If the Remote Manager is running, verify that the Portmapper is running on the node and that the RPC interface in the Remote Manager has been started.

**Message:** NOCOMPND, compound name is not allowed for this entity (only server and group).

- **Explanation:** An attempt was made to add a collection record using a compound name for an entity that is not a server or group. Compound names (that is, names that contain an application specification and a process specification) are valid for only servers and groups.
- **User Action:** Modify the command so it does not include a compound name. For more help about adding collection records, use the ACMSMGR HELP ADD COLLECTION command.

**Message:** NOCREDS, could not get credentials for <node::user>

- **Explanation:** The credentials file for the user either could not be found or could not be opened by the client process. The credentials file is created when a user explicitly logs in to the Remote Manager (that is, the user supplies a user name and password). A separate credentials file is created for each node to which a particular process logs in. The logical name ACMS\$MGMT\_CREDS\_DIR is used to point to the directory containing credentials files.

Note that credentials files are process-specific (PID) and node specific.

- **User Action:** Verify that the ACMS\$MGMT\_CREDS\_DIR logical is pointing to a valid disk and directory in which a credentials file has been created; verify that the process has read access to the files in the directory. The process may have to log in to the Remote Manager again to create a new credentials file.

**Message:** NODATA, no <entity-type> data was found for <node-name>

- **Explanation:** The request to get information about the entity type indicated in the message returned no data. This message occurs when no instances of the particular process are running.
- **User Action:** No action is required. If the process had been running previously, you may be able to see the information by resubmitting the command with the /ALL qualifier.

**Message:** NOFACILITY, facility must be specified when setting trace level

- **Explanation:** This message is obsolete.
- **User Action:** No action is required.

**Message:** NONODE, node must be specified as a logical or an argument

- **Explanation:** Each ACMSMGR command needs a node name to be specified. The node name can be specified either as a command qualifier (for example, /NODE=mynode) or by the logical name ACMS\$MGMT\_SERVER\_NODE. Multiple nodes can be specified in a comma-separated list (for example, /NODE=node1,node2). To specify a list of nodes when defining the logical name ACMS\$MGMT\_SERVER\_NODE, enclose the entire list in double quotation marks. For example:

```
$ DEFINE ACMS$MGMT_SERVER_NODE "NODE1 ,NODE2 "
```

- **User Action:** Modify the command to include the /NODE qualifier, or define the logical ACMS\$MGMT\_SERVER\_NODE to include at least one node name.

**Message:** NORMAL, operation completed

- **Explanation:** The command completed successfully.
- **User Action:** No action is required.

**Message:** NOVAL, qualifier <qualifier> requires a value string

- **Explanation:** The qualifier indicated requires a value string, but none was provided.
- **User Action:** Modify the command to include a valid value string and resubmit the command. To learn more about the valid values for a given qualifier, use the ACMSMGR HELP command.

**Message:** OLDDATA, this data is old and may not accurately reflect the running system

- **Explanation:** The data being displayed may contain information about processes that are no longer running. Old, or stale, data is displayed only if the /ALL qualifier was included with the command. The old records are flagged with an asterisk (\*) in the first character of the node name.
- **User Action:** No action is required. Remove the /ALL qualifier if you do not want to see old data.

**Message:** PARAMFAIL, parameter update failed for parameter <parameter>. ACMS is not available or does not respond.

- **Explanation:** A request to update an interval value failed because the Remote Manager could not pass the changed value to the ACMS process.
- **User Action:** Examine the Remote Manager log for additional messages that might provide more information about the failure, and ensure that the ACMS trace monitor is running (process ACMS \$TRACE\_MON). If the trace monitor is not running, check whether the trace monitor logical ACMS\$TRACE\_MBX is defined.

Also ensure that the ACMS Remote Manager has been started (ACMSMGR START SYS). If the problem persists, restart ACMS and the Remote Manager.

**Message:** PASS2BIG, password is too long, please reenter

- **Explanation:** The password specified exceeds the maximum allowed length of 32 characters.
- **User Action:** Modify the password to be no longer than 32 characters and reenter it.

**Message:** QUALCONFLICT, qualifier <qualifier> is not supported in combination with other qualifier(s) on this command line

- **Explanation:** Multiple, mutually exclusive qualifiers were provided for an ACMSMGR command.
- **User Action:** Review the qualifiers and determine which are mutually exclusive. Reissue the command with the appropriate combination of qualifiers. For a list of variables and their valid values, see the ACMSMGR online help.

**Message:** STORUPDINV, /stored was specified for <field>, but this value cannot be stored. No update was performed

- **Explanation:** An attempt was made to modify Configuration class data for an entity using ACMSMGR SET <entity> /STORED command; however, one of the specified variables does not have a stored value.

- **User Action:** Reissue the command either without the /STORED qualifier or with only variables that have a stored value. For a list of variables and their valid values, see the ACM SMGR online help.

**Message:** UNKCMD, unrecognized command <command>

- **Explanation:** The command verb indicated in the message is not valid.
- **User Action:** Modify the command to include a valid command verb. To learn more about valid verbs, use the ACM SMGR HELP command.

**Message:** UNKCMDOBJ, unrecognized object <command object> for this command

- **Explanation:** The command object indicated in the message is not valid.
- **User Action:** Modify the command to include a valid command object. To learn more about valid command objects, use the ACM SMGR HELP command.

**Message:** USE\_PROXY, username not supplied, proxy access will be attempted

- **Explanation:** This message is obsolete.
- **User Action:** No action is required.

**Message:** WRONGPARAM, parameter type is not valid for this entity type, please correct and reexecute command

- **Explanation:** The parameter type in the command is not valid for the entity type specified. Each parameter is valid for only a particular set of entity types; the combination specified is not a valid pair.
- **User Action:** Modify the command to include a valid combination of entity type and parameter. To learn more about valid combinations, use the ACM SMGR HELP command.

**Message:** WRONGQUAL, qualifier <qualifier> is not supported for this verb and object, please correct and re-execute command

- **Explanation:** A command qualifier was specified that is not valid for the verb/object combination specified.
- **User Action:** Modify the command to include a valid qualifier. To learn more about the valid qualifiers for a verb/object combination, use the ACM SMGR HELP command.

## C.3. ACMSCFG Messages

The following error messages pertain to the ACMSCFG process.

**Message:** ADDREC, record does not exist, creating new record from defaults

- **Explanation:** This message is obsolete.
- **User Action:** No action is required.

**Message:** BAD\_TIME, invalid time <time>

- **Explanation:** This status code has not been implemented yet.

- **User Action:** No action is required.

**Message:** BAD\_VALUE, invalid qualifier, cannot interpret value <value>

- **Explanation:** A null or invalid value was provided to a qualifier.
- **User Action:** Correct the value and resubmit the command. To learn more about ACMSCFG qualifiers and valid values, use the ACMSCFG HELP command.

**Message:** CLASS\_REQ, collection class is required, please resubmit command

- **Explanation:** This status code has not been implemented yet.
- **User Action:** No action is required.

**Message:** CONFIG\_NORMAL, operation completed

- **Explanation:** The ACMSCFG command completed successfully.
- **User Action:** No action is required.

**Message:**

- **Explanation:**
- **User Action:**

**Message:** END\_TOO\_EARLY, end time must be greater than begin time

- **Explanation:** This status code has not been implemented yet.
- **User Action:** No action is required.

**Message:** ENTITY\_REQ, entity type is required, please resubmit command

- **Explanation:** A command was issued that requires an entity type to be specified.
- **User Action:** Resubmit the command, including the /ENTITY=<entity\_type> qualifier and the appropriate entity type.

**Message:** ERRADD, error adding record

- **Explanation:** This message is obsolete.
- **User Action:** No action is required.

**Message:** ERRDEL, error deleting record

- **Explanation:** An error occurred while a record was being deleted. This message is preceded by a status message returned by RMS describing the error. The problem is usually an environmental one—for example, a locked file, insufficient privileges, and so on.
- **User Action:** Refer to the message immediately preceding this one that describes the error returned from RMS.

**Message:** ERROR\_OPEN, could not open file <filename>

- **Explanation:** This message is obsolete.

- **User Action:** No action is required.

**Message:** ERRUP, error updating record

- **Explanation:** An error occurred while a record was being updated. This message is preceded by a status message returned by RMS describing the error. The problem is usually an environmental one—for example, a locked file, insufficient privileges, and so on.
- **User Action:** Refer to the message immediately preceding this one that describes the error returned from RMS.

**Message:** ID\_REQ, entity name is required, please resubmit command

- **Explanation:** This status code has not been implemented yet.
- **User Action:** No action is required.

**Message:** IF\_INVALID, invalid interface <interface>

- **Explanation:** The interface name indicated is unrecognizable.
- **User Action:** Modify the /INTERFACE qualifier to include a valid interface type. To learn about valid interface types, use the ACMSCFG HELP command.

**Message:** IF\_REQ, interface type is required, please resubmit command

- **Explanation:** The interface type is required in order to update the correct record. The command that was submitted did not specify the interface type.
- **User Action:** Modify the command to include the /INTERFACE qualifier, along with the desired interface type. To learn more about updating interfaces, use the ACMSCFG HELP command.

**Message:** INSUF\_ARGS, insufficient arguments

- **Explanation:** An insufficient number of arguments was passed to the ACMSCFG utility. At least one argument is required.
- **User Action:** Modify the command to include at least one argument. Use the ACMSCFG HELP command to learn about the various ACMSCFG commands.

**Message:** INVPARAMTYPE, parameter type <parameter> is not valid for this entity type, please correct and re-execute the command

- **Explanation:** The parameter type indicated is not valid for the entity type specified. Each parameter is valid for only a particular set of entity types; the combination specified is not a valid pair.
- **User Action:** Modify the command to include a valid combination of entity type and parameter. To learn more about valid combinations, use the ACMSCFG HELP command.

**Message:** INVSTATE, invalid state <state>

- **Explanation:** The state indicated is unrecognizable.
- **User Action:** Modify the qualifier to include a valid state. To learn about valid states, use the ACMSCFG HELP command.

**Message:** INVVALUE, qualifier <value> contains an invalid value, please correct and resubmit

- **Explanation:** A qualifier was specified with an invalid value.
- **User Action:** Modify the command to include a valid value with the qualifier. To learn more about valid values for the qualifier, use the ACMSCFG HELP command.

**Message:** NAME\_REQ, entity name is required, please resubmit command

- **Explanation:** This message is obsolete.
- **User Action:** No action is required.

**Message:** NODEFADD, records for this class cannot be added

- **Explanation:** An attempt was made to add a record for the Id and Config classes, which is not allowed. New records for Id and Config classes cannot be added.
- **User Action:** Any attempt to add records for Id and Config classes will fail.

**Message:** NODEFDELETE, this record cannot be deleted, it is a mandatory default

- **Explanation:** An attempt was made to delete a record that cannot be deleted. Default collection records for Id and Config classes cannot be deleted.
- **User Action:** Any attempt to delete these records will fail.

**Message:** NODEFDISABLE, collection cannot be disabled for this entity and class

- **Explanation:** An attempt was made to modify the default Id and Config class records, which is not allowed. Default collection records for Id and Config classes cannot be deleted or modified.
- **User Action:** Any attempt to modify records for Id and Config classes will fail.

**Message:** NOFILE, unable to open file <filename>

- **Explanation:** The configuration file could not be opened. The specification for the file to be opened is determined by the translation of the logical name ACMS\$MGMT\_CONFIG, or, if the logical name is not defined, the default file name is SYSSYSROOT:[SYSEXE]ACMS\$MGMT\_CONFIG.ACM. The ACMSCFG utility will ask you whether or not you want to create a new file.
- **User Action:** If the file does not exist and you would like to have a new file created with default values, respond to the prompts. If the file does exist, investigate why it could not be opened by the ACMSCFG utility.

**Message:** NO\_QUAL, insufficient arguments—no qualifiers, please correct and resubmit

- **Explanation:** A command that requires at least one qualifier was submitted without any qualifiers.
- **User Action:** Modify the command to contain at least one qualifier. To learn more about ACMSCFG commands their qualifiers, use the ACMSCFG HELP command.

**Message:** NORECDEL, record does not exist, no record deleted

- **Explanation:** An attempt was made to delete a record that does not exist.



- **User Action:** Correct the command to include the correct record identifiers. For collection records, entity type, class name, and entity name uniquely identify records; for trap records, entity type, entity name, and parameter name uniquely identify records.

**Message:** NORECUP, record does not exist, no record updated

- **Explanation:** An attempt was made to update a record that does not exist.
- **User Action:** Correct the command to include the correct record identifiers. For collection records, entity type, class name, and entity name uniquely identify records; for trap records, entity type, entity name, and parameter name uniquely identify records. For interface records, interface type uniquely identifies the record.

**Message:** NOT\_ADDED, no record added

- **Explanation:** This message is obsolete.
- **User Action:** No action is required.

**Message:** NOUPDATES, no changes to make, no updates made

- **Explanation:** A command was issued to update the parameter record, but no parameters were specified for update. No changes were made to the record.
- **User Action:** Modify the command to include at least one parameter to be modified.

**Message:** NULLQUAL, null qualifier <qualifier>, nothing to do

- **Explanation:** A qualifier was provided that requires a value, but no value was specified.
- **User Action:** Modify the command to include a valid value with the qualifier. To learn more about valid values for the qualifier, use the ACMSCFG HELP command.

**Message:** PARAM\_INVALID, parameter <parameter name> is not valid for this entity

- **Explanation:** This status code has not been implemented yet.
- **User Action:** No action is required.

**Message:** PARAM\_REQ, parameter type is required, please resubmit command

- **Explanation:** This status code has not been implemented yet.
- **User Action:** No action is required.

**Message:** PAST\_BEGIN, begin time must be in the future

- **Explanation:** This status code has not been implemented yet.
- **User Action:** No action is required.

**Message:** TIMERID\_REQ, timer id is required, please resubmit command

- **Explanation:** This status code has not been implemented yet.
- **User Action:** No action is required.

**Message:** UNKCLASS, unrecognized class <class>

- **Explanation:** The class type indicated is unrecognizable.
- **User Action:** Modify the /CLASS qualifier to include a valid class. To learn about valid classes, use the ACMSCFG HELP command.

**Message:** UNKENTITY, unrecognized entity <entity>

- **Explanation:** The entity type indicated is unrecognizable.
- **User Action:** Modify the /ENTITY qualifier to include a valid entity type. To learn about valid entity types, use the ACMSCFG HELP command.

**Message:** UNKNOWN\_OBJ, unknown obj <object>

- **Explanation:** The command object specified is not valid.
- **User Action:** Modify the command to include a valid command object. The valid command objects vary depending on the command verb. Use the ACMSCFG HELP command to learn more about valid command verbs and objects.

**Message:** UNKPARAM, unrecognized param <param>

- **Explanation:** The parameter indicated is unrecognizable.
- **User Action:** Modify the /PARAMETER qualifier to include a valid parameter name. To learn about valid parameters, use the ACMSCFG HELP command.

**Message:** UNKQUAL, unrecognized qualifier <qualifier>, please correct and re-execute command

- **Explanation:** The qualifier indicated is unrecognized.
- **User Action:** Modify the command to include a valid qualifier. To learn more about valid qualifiers, use the ACMSCFG HELP command.

**Message:** UNKVERB, unrecognized verb <verb>, please correct and resubmit

- **Explanation:** The verb indicated is unrecognized.
- **User Action:** Modify the command to include a valid verb. To learn more about valid verbs, use the ACMSCFG HELP command.

**Message:** VALTOOBIG, value is too large: <value>, please correct and resubmit

- **Explanation:** A value was provided that is greater than the allowed maximum.
- **User Action:** Modify the command to include a valid value with the qualifier. To learn more about valid values for the qualifier, use the ACMSCFG HELP command.

**Message:** VALTOOSMALL, value is too small: <value>, please correct and resubmit

- **Explanation:** A value was provided that is less than the allowed minimum.
- **User Action:** Modify the command to include a valid value with the qualifier. To learn more about valid values for the qualifier, use the ACMSCFG HELP command.

## C.4. ACMSSNAP Messages

The following error messages pertain to the ACMSSNAP process.

**Message:** FILEISOPEN, a file is already open. Use the CLOSE command to close the current file

- **Explanation:** A request was made to process an ACMS data snapshot file that is already open. Only one file can be open at a time.
- **User Action:** No action is required.

**Message:** NOFILEOPEN, no file is open. Use the OPEN command to open a file first

- **Explanation:** A request was made to process an ACMS data snapshot file, but no file has been opened. A data snapshot file must be open in order for the command to be executed.
- **User Action:** Use the ACMSSNAP OPEN command to open the file; then reissue the command.



# Index

