

VSI OpenVMS

VSI DECnet-Plus DECdns Management Guide

Document Number: DO-DNSMGT-01A

Publication Date: October 2021

Revision Update Information: This is a new manual.

Operating System and Version: VSI OpenVMS Integrity Version 8.4-2
VSI OpenVMS Alpha Version 8.4-2L1

VSI DECnet-Plus DECdns Management Guide



VMS Software

Copyright © 2021 VMS Software, Inc. (VSI), Burlington, Massachusetts, USA

Legal Notice

Confidential computer software. Valid license from VSI required for possession, use or copying. Consistent with FAR 12.211 and 12.212, Commercial Computer Software, Computer Software Documentation, and Technical Data for Commercial Items are licensed to the U.S. Government under vendor's standard commercial license.

The information contained herein is subject to change without notice. The only warranties for VSI products and services are set forth in the express warranty statements accompanying such products and services. Nothing herein should be construed as constituting an additional warranty. VSI shall not be liable for technical or editorial errors or omissions contained herein.

HPE, HPE Integrity, HPE Alpha, and HPE Proliant are trademarks or registered trademarks of Hewlett Packard Enterprise.

Intel, Itanium and IA-64 are trademarks or registered trademarks of Intel Corporation or its subsidiaries in the United States and other countries.

Preface	xi
1. About VSI	xi
2. Intended Audience	xi
3. Document Structure	xi
4. Related Documents	xii
5. VSI Encourages Your Comments	xii
6. OpenVMS Documentation	xii
7. Typographical Conventions	xii
Chapter 1. Introduction to DECdns	1
1.1. How DECdns Works	1
1.2. Examples of Client Applications that Use DECdns	3
1.3. How People Use DECdns	4
1.4. What's in a Namespace?	4
1.4.1. Replicas and Their Contents	5
1.4.1.1. Object Entries	6
1.4.1.2. Soft Links	7
1.4.1.3. Child Pointers	7
1.4.2. Putting It All Together	7
1.5. How DECdns Protects Names	8
1.6. Available Management Tools	9
1.6.1. DECdns Control Program	9
1.7. Management Tasks	10
Chapter 2. How DECdns Looks Up Names	13
2.1. Structure of a Name	13
2.2. Translating from Names to Resources	13
2.3. Resolving Names and Addresses with the Naming Cache	18
2.4. How DECdns Finds Names	19
2.5. Short Forms of DECdns Names	21
2.5.1. How Node Synonyms Work	21
2.5.2. Name Abbreviation Methods	22
2.5.3. Local Root	22
2.5.4. How Local Name Substitution Works	22
Chapter 3. How DECdns Updates Data	25
3.1. Update Propagation	25
3.2. Skulk Operation	25
3.3. How Timestamps Help Keep Data Consistent	26
Chapter 4. Using the DECdns Control Program	27
4.1. Elements of a DECdns Command	27
4.2. DECdns Entities	27
4.3. Attribute Groups	29
4.4. Prepositional Phrases	29
4.5. NCL Access Control Information	30
4.6. Supplementary Commands	30
4.7. Wildcards	33
4.8. Editing the Commands	33
Chapter 5. Managing DECdns Access Control	35
5.1. How DECdns Access Control Works	35
5.1.1. Specifying a DECdns Version 2 Principal	35
5.1.2. Specifying a DNS Version 1 Principal	36

5.1.3. Specifying Group Principals	36
5.1.4. DECdns Access Rights and Their Meanings	36
5.1.5. How DECdns Checks Access	38
5.2. Adding, Modifying, and Denying Access	39
5.2.1. Adding Access	39
5.2.2. Modifying Existing Access	39
5.2.3. Making Access Assignment Easier	40
5.2.3.1. Using Automatic Rights Propagation	40
5.2.3.2. Suppressing Automatic ACE Propagation	41
5.2.3.3. Creating Default ACEs	41
5.2.4. Using Null ACEs to Deny Access	42
5.3. Setting Up Access Control in a New Namespace	43
5.3.1. Adding Members to Your Namespace Administrator Group	43
5.3.2. Adding Access for Your Namespace Administrator Group	44
5.3.3. Implementing a General Access Control Policy	45
5.3.3.1. Full Access Policy	45
5.3.3.2. Read, Write, and Test Policy	46
5.3.3.3. Read and Test Policy	46
5.3.3.4. Explicit Access Policy	46
5.4. Displaying Access Rights	47
5.5. Removing Access	48
5.6. Managing Groups	49
5.6.1. Creating a Group	50
5.6.2. Adding Group Members	50
5.6.3. Modifying Group Membership	51
5.6.4. Removing Group Members	52
5.6.5. Removing Group Members from Multiple Groups	53
5.6.6. Deleting a Group	53
5.7. Modifying Principals and Removing Access for a Subtree	54
5.7.1. Modifying Principals	54
5.7.2. Removing Access from Multiple Names	55
Chapter 6. Managing Clerks, Servers, and Clearinghouses	57
6.1. Monitoring Status	57
6.2. Monitoring Counters	58
6.3. Monitoring Clerk Communication with Specific Clearinghouses	59
6.4. Monitoring the Contents of a Clearinghouse	60
6.5. Modifying a Clerk's Timeout Interval	60
6.6. Modifying a Clerk To Use the Cluster Alias on Server Requests	61
6.7. Deleting and Restarting Clerks and Servers	61
6.7.1. Deleting a Clerk	62
6.7.2. Deleting a Server	63
6.7.3. Restarting a Deleted Clerk	65
6.8. Controlling the LAN Devices Used By DECdns	65
6.9. Preserving a Clearinghouse Across a Server System Upgrade	65
6.10. Backing Up Namespace Information	66
6.10.1. Using Replication to Back Up Namespace Information	66
6.10.2. Using the Dump/Merge Facilities to Back Up Directories and Their Contents	67
6.10.3. Using Operating System Backups	67
Chapter 7. Managing Directories	69
7.1. Creating a Directory	69

7.2. Creating a Replica	70
7.3. Deleting a Replica	72
7.4. Skulking a Directory	73
7.5. Adjusting a Directory's Convergence	74
Chapter 8. Viewing the Structure and Contents of a Namespace	77
8.1. Using Prepositional Phrases in show and directory Commands	77
8.2. Using the show Command	77
8.3. Using the directory Command	80
Chapter 9. Restructuring a Namespace	83
9.1. Managing Soft Links	83
9.1.1. Creating a Soft Link	83
9.1.2. Changing a Soft Link's Destination Name	85
9.1.3. Changing a Soft Link's Expiration or Extension Time	85
9.2. Modifying a Directory's Replica Set	85
9.2.1. Changing the Replica Type of a Replica	86
9.2.2. Excluding a Replica from a Replica Set	87
9.3. Deleting Directories	89
9.3.1. Deleting a Bottom-Level Directory	89
9.3.2. Deleting a Subtree of Directories	90
9.4. Merging Directories	91
9.4.1. Overview of the Merge Procedure	91
9.4.2. Basic Merge and Append Operations	92
9.4.2.1. Performing a Basic Merge Operation	92
9.4.2.2. Performing a Basic Append Operation	93
9.4.3. Merging Directories with a Single Command	95
9.4.4. Handling Clearinghouse Object Entries	95
9.4.5. Using the Failures File	96
9.4.5.1. Handling Duplicate Names	96
9.4.5.2. Handling Unreachable Name Failures	97
9.4.6. Adjusting Access After a Merge	97
9.4.7. Handling Changed Node Object Entries	98
9.4.8. Merging Two Namespaces	98
9.5. Relocating a Clearinghouse	99
9.5.1. Dissociating a Clearinghouse from Its Host Server System	100
9.5.2. Copying the Clearinghouse Database Files to the Target Server System	100
9.5.3. Re-creating and Enabling the Clearinghouse on the Target Server	101
9.6. Deleting a Clearinghouse	101
Chapter 10. Using the DECdns Configuration Program	105
10.1. Running the DECdns Configuration Program	105
10.2. Changing a Clerk's Default Namespace	106
10.3. Establishing Communications with an Off-LAN Server	107
10.4. Configuring a DECdns Server in an Existing Namespace	108
10.4.1. Before You Configure a Server	108
10.4.1.1. Verifying DECdns Server Software and License Requirements	110
10.4.1.2. Granting the Access Required for Clearinghouse Creation	111
10.4.2. Configuring the Server	112
10.4.3. Creating an Additional Clearinghouse on an Existing Server	114
10.4.4. Converting an Existing DNS Version 1 Clearinghouse to DECdns Version 2 Format	114
10.4.5. Clearinghouse Conversion Warnings and Informational Messages	118
10.4.6. Reconfiguring a DECdns Server	118

10.5. Displaying Address Information for Your Local Node	118
10.6. Creating and Initializing a New Namespace	119
Chapter 11. DECdns Control Program Command Dictionary	121
add clearinghouse access	124
add directory access	125
add group access	126
add group member	127
add link access	128
add object	129
add object access	130
change subtree access	131
change subtree group member	132
clear dns server clearinghouse	133
create child	134
create directory	135
create dns clerk	135
create dns clerk known namespace	136
create dns clerk manual nameserver	137
create dns server	138
create dns server clearinghouse	139
create group	140
create link	141
create object	141
create replica	142
delete child	143
delete directory	144
delete dns clerk	145
delete dns clerk known namespace	145
delete dns clerk manual nameserver	146
delete dns server	147
delete dns server clearinghouse	147
delete group	148
delete link	149
delete object	149
delete replica	150
delete subtree	151
directory child	152
directory clearinghouse	153
directory directory	154
directory group	155
directory link	155
directory object	156
disable dns clerk	157
disable dns server	158
disable dns server clearinghouse	159
dump dns clerk cache	159
dump subtree	160
enable dns clerk	161
enable dns server	161
enable dns server clearinghouse	162
initialize dns server	163
merge file	164

merge subtree	165
recreate directory	166
recreate link	167
recreate object	168
remove clearinghouse access	169
remove directory access	169
remove group access	170
remove group member	171
remove link access	172
remove object	172
remove object access	173
remove subtree access	174
remove subtree group member	175
replace link	176
replace object	176
replace subtree	177
set directory	178
set directory to new epoch	180
set directory to skulk	181
set dns clerk	182
set dns clerk known namespace	183
set group	184
set link	184
set object	185
show child	186
show clearinghouse	188
show clearinghouse access	192
show directory	193
show directory access	197
show dns clerk	199
show dns clerk known namespace	202
show dns clerk manual nameserver	205
show dns clerk remote clearinghouse	207
show dns server	210
show dns server clearinghouse	213
show group	217
show group access	219
show link	221
show link access	223
show object	225
show object access	227
show replica	229
Chapter 12. DECdns Problem Solving	233
12.1. Isolating the Source of a Problem: General Suggestions	233
12.1.1. Obtain Basic DECnet Information	234
12.1.2. Obtain Basic Clerk and Server Information	235
12.1.2.1. Checking the DECdns Clerk	235
12.1.2.2. Checking the DECdns Server	236
12.1.2.3. Checking the Clerk and Server Software Versions	236
12.1.3. Investigating the DECdns Clerk	236
12.1.3.1. DECdns Clerk Cache Information	236
12.1.3.2. DECdns Clerk Known Namespaces	238

12.1.4. Investigating the DECdns Server	238
12.1.4.1. Remote Checks on the Server	238
12.1.4.2. Local Checks on the Server	240
12.1.4.3. Determining a Node Name from a Clearinghouse NSAP Address	240
12.2. Handling Communication Errors	241
12.2.1. Identifying Clearinghouses to Which Communication Failed	241
12.2.2. Determining Whether Communication Errors Are Caused by DECdns or DECnet	244
12.3. Handling Skulk Failures	246
12.3.1. General Considerations	246
12.3.2. Skulk Problems in Mixed Server Environments	246
12.4. Clerk Tuning	247
12.4.1. Defining Quotas for the DNS\$ADVER Process	247
12.4.2. Clerk Cache Size and the GBLPAGFIL System Parameter	248
12.5. Solving Server Startup Problems	249
12.5.1. Server Startup Delay in a TCP/IP Environment	249
12.6. Server Tuning	249
12.6.1. Tuning for Increased Clerk Use	249
12.6.2. Tuning for Increased Database Size	251
12.6.3. The Server Configuration File - DNS.CONF	251
12.7. Solving Common Access Control Problems	255
12.7.1. Access Problems Viewing Namespace Information	255
12.7.2. Access Problems Creating a Clearinghouse	256
12.7.3. Access Problems Creating a Directory	257
12.7.4. Access Problems Deleting a Directory	257
12.7.5. Access Problems Creating a Replica	258
12.7.6. Access Problems Deleting a Replica	258
12.7.7. Access Problems Modifying a Directory's Replica Set	259
12.7.8. Restoring Access to a Name	259
12.8. Handling Clearinghouse Creation Failures	260
12.8.1. Granting Required Access	260
12.8.2. Allowing a Directory to Store Clearinghouse Object Entries	261
12.8.3. Verifying Server Node Registration and Address Information	262
12.8.4. Verifying Availability and Connectivity to Clearinghouses	262
12.9. Restoring a Corrupted Clearinghouse	263
12.10. Restoring a Deleted Child Pointer	266
12.11. Restoring a Missing Clearinghouse Object Entry	267
12.12. Handling Node Verification Failures	268
12.13. Breaking Soft Link Loops and Group Loops	270
12.14. Eliminating Ambiguous Namespace Nicknames	271
12.14.1. Locating the Source of an Ambiguous Nickname	272
12.14.2. Eliminating an Ambiguous Nickname	272
12.15. Fixing Clock Synchronization Errors	273
12.16. Handling Clerk and Server Software Errors	274
12.17. Using Tracing Facilities	274
12.17.1. Tracing the Advertiser	274
12.17.2. Tracing the Clerk	274
12.17.3. Tracing the Server	275
12.17.4. Tracing DECnet	276
Appendix A. DECdns Naming Guidelines	279
A.1. Valid Characters and Syntax Rules	279
A.2. General Naming Guidelines	281

A.3. Guidelines for Naming Clearinghouses	282
A.4. Guidelines for Naming Namespaces	282
Appendix B. Special Clearinghouse Rules	285
Appendix C. DECdns Error Messages	289
Appendix D. DECdns Events	303
Appendix E. Location of DECdns Files	309
Appendix F. DECdns Version Interoperability	313
F.1. Version 2 Directories Cannot Be Replicated in Version 1 Clearinghouses	313
F.2. Double ACEs on Directories Replicated at Mixed-Version Servers	313
F.3. Command Interfaces Differ	314
F.4. Clerks on Nodes with Extended Addresses	314
F.5. Version 2 Clerks Connecting to Version 1 Servers Across a WAN	314
F.6. Version 1 Clerks Contacting a Version 2 Server's Namespace	315
Appendix G. Sample Command Files	317
G.1. Deleting Server Files	317
G.1.1. Command File	317
G.2. Replicating A Server's Directories Into a New Clearinghouse	318
Appendix H. The DECdns Browser Utility	325
H.1. Starting the Browser	325
H.2. Expanding and Collapsing Directories	325
H.3. Namespace Display Formats	326
H.4. Using a Virtual Root	328
H.5. Filtering the Namespace Display	329
H.6. Navigating the Namespace	329
H.6.1. Outline Navigation Aids	329
H.6.2. Tree Navigation Aids	331

Preface

The VSI Distributed Name Service (DECdns) is a networkwide service that enables users to assign names to resources and then use those resources without needing to know their physical location in the network. This manual introduces DECdns concepts and describes how to manage a namespace and solve problems after you install and configure the software. For information on planning, installing, and configuring DECdns, see the documentation for your platform.

1. About VSI

VMS Software, Inc. (VSI) is an independent software company licensed by Hewlett Packard Enterprise to develop and support the OpenVMS operating system.

VSI seeks to continue the legendary development prowess and customer-first priorities that are so closely associated with the OpenVMS operating system and its original author, Digital Equipment Corporation.

2. Intended Audience

This manual is intended for two audiences: namespace administrators, who oversee the design of the namespace and the creation of names in it, and server managers, who oversee day-to-day operations at DECdns server nodes. Both audiences should have a sound understanding of basic DECdns concepts before starting to use the software. Information about management and problem-solving tasks may apply to either of the two audiences, depending on the size of the namespace and the scope of the task (in small networks, one person may take the role of both namespace administrator and server manager). This manual points out the tasks that would normally be the responsibility of each audience.

3. Document Structure

This manual is organized into twelve chapters and eight appendixes.

- Chapter 1, Chapter 2, and Chapter 3 introduce basic DECdns concepts and describes how to manage DECdns.
- Chapter 4, Chapter 5, Chapter 6, Chapter 7, Chapter 8, Chapter 9, and Chapter 10 are the DECdns Control Program (DNSCP) command dictionary.
- Chapter 11 and Chapter 12 explain how to isolate and solve DECdns problems.
- Appendix A lists valid characters and syntax for DECdns names and provides naming guidelines.
- Appendix B explains two rules that affect the creation of clearinghouses and directories.
- Appendix C lists and explains error messages that occur while running DECdns.
- Appendix D lists and explains DECdns events.
- Appendix E contains information on the location of the DECdns files on OpenVMS.
- Appendix F describes interoperability considerations for DECdns and the Distributed Name Service (DNS) Version 1.

- Appendix G includes samples of useful command files.
- Appendix H explains how to use the unsupported DECdns Browser utility to view the namespace.

4. Related Documents

The VSI Distributed Time Service (DECdts) is used with the DECdns product. Refer to the following manuals for details on DECdts:

- *VSI DECnet-Plus for OpenVMS DECdts Management*
- *VSI DECnet-Plus DECdts Programming*

Additional information about DECdns, including namespace planning guidelines, is in other parts of the documentation set for your platform.

OpenVMS users should refer to the following manuals for additional information:

- *VSI DECnet-Plus Planning Guide*
- *VSI DECnet-Plus for OpenVMS Introduction and User's Guide*
- *VSI DECnet-Plus for OpenVMS Installation and Configuration*
- *DECnet-Plus for OpenVMS Applications Installation and Advanced Configuration Guide*
- *VSI DECnet-Plus for OpenVMS Network Management Guide*
- *DECnet-Plus for OpenVMS Installation and Quick Reference*
- *DECnet-Plus for OpenVMS Network Management and Quick Reference Card*

5. VSI Encourages Your Comments

You may send comments or suggestions regarding this manual or any VSI document by sending email to the following Internet address: <docinfo@vmssoftware.com>. Users who have OpenVMS support contracts through VSI can contact <support@vmssoftware.com> for help with this product.

6. OpenVMS Documentation

The full VSI OpenVMS documentation set can be found on the VMS Software Documentation web page at <https://vmssoftware.com/resources/documentation/>.

7. Typographical Conventions

The following conventions are used in this manual:

special type	Indicates a literal example of system output or user input. In text, indicates DECdns names, command names, keywords, node names, file names, path names, directories, utilities, and tools.
Bold	Represents the introduction of a new term.

<i>Italics</i>	Indicate a variable for which either the user or the system supplies a value.
UPPERCASE	Indicates the name of a rights identifier code, or an abbreviation of a system privilege.
[@]	In format descriptions, brackets enclose optional items. Default values apply for unspecified options. (Do not type the brackets.)
(@)	In format descriptions, if you choose more than one option, parentheses indicate that you must enclose the choices in parentheses.
Ctrl/ <i>x</i>	Indicates that you hold down the Ctrl key while you press another key (specified here by <i>x</i>).
\$	Represents the OpenVMS DCL system prompt.

Chapter 1. Introduction to DECdns

The VSI Distributed Name Service (DECdns) is a networkwide service that makes it possible to use network resources without knowing their physical location. Users and applications can assign DECdns names to resources such as nodes, disks, and files. The creator of a name also supplies other relevant information, such as the resource's network address, for DECdns to store. Users then need to remember only the name, and DECdns acts as a lookup service, providing the rest of the data when necessary.

The ability to store data with a name is especially useful in a changing and growing distributed computing environment. Traditional references to resources such as disks, files, and print queues include the name of the node where they reside. Now, because DECdns stores that information along with—but not as part of—a name, a resource can be moved from one node to another without making users change the way they refer to it.

DECnet-Plus software can use DECdns to store node names. The major benefit of using DECdns to store node names is ease of maintenance. With DECdns, it is not necessary to maintain a node database on every system in the network. A few DECdns servers store node names, and all other nodes in the network can depend on those servers for node name-to-address mapping. When data associated with the node name changes, DECdns propagates the change automatically to all servers that store that node name.

Another benefit of using DECdns node names with DECnet-Plus software is that they can be longer than DECnet Phase IV names and hence more descriptive. Whereas Phase IV node names were limited to 6 characters, any DECdns name, including a node name, can be as long as 255 characters. See Appendix A for complete guidelines for all DECdns names. In addition, with DECdns, you can give printers, disks, and files names that are independent of their physical location. If the resource's address (or some other characteristic) changes, network users and applications are unaffected: the same name is used. The change is recorded with the name's associated characteristics that are stored in the DECdns database.

DECdns also lets you distribute data among several nodes so that no one node has to store all of it (thereby saving disk space). This feature is particularly valuable in large networks. It also is possible to **replicate** names; that is, to store copies of names on more than one node. DECdns automatically keeps multiple copies consistent. The ability to distribute and replicate information has many benefits, including the following:

- **Availability** — Because you can store the same name in more than one place, data is likely to be available even in the event of a system or network failure.
- **Efficiency** — DECdns finds names efficiently because you can store them close to where they are used most often.
- **Load sharing** — Because names are in more than one place, several nodes can share the load of looking them up.
- **Expandability** — New names are easily accommodated as the network grows and more applications use DECdns.

DECdns is flexible enough to support small or large networks.

1.1. How DECdns Works

Operation of the name service involves several major participants:

- Client applications
- Servers
- Clerks
- Clearinghouses

DECdns uses a client/server model. An application that depends on DECdns to store and retrieve information for it is a **client** of DECdns. Client applications create names for resources on behalf of their users. Through a client application, a user can supply other information for DECdns to store with a name. This information is stored in data structures called **attributes**. Then, when a client application user refers to the resource by its DECdns name, DECdns retrieves from the attributes the data to be used by the client application.

A system running DECdns server software is a **DECdns server**. A DECdns server stores and maintains DECdns names and handles requests to create, modify, or look up data. You designate a system as a DECdns server when configuring the DECnet-Plus software.

A component called the **clerk** is the interface between client applications and DECdns servers. A clerk must exist on every DECnet-Plus node using DECdns and is created during configuration of the network software. The clerk receives a request from a client application, sends the request to a server, and returns the resulting information to the client. This process is called a **lookup**. The clerk is also the interface through which client applications create and modify names. One clerk can serve many client applications.

The clerk caches, or saves, the results of lookups so it does not have to repeatedly go to a server for the same information. The cache is written to disk periodically so the information can survive a system reboot or the restart of an application. Caching improves performance and reduces network traffic.

Figure 1.1 shows a sample configuration of DECdns clerks and servers on a nine-node local area network (LAN). Every node is a clerk, and DECdns servers run on two selected nodes.

Figure 1.1. Sample DECdns LAN Configuration

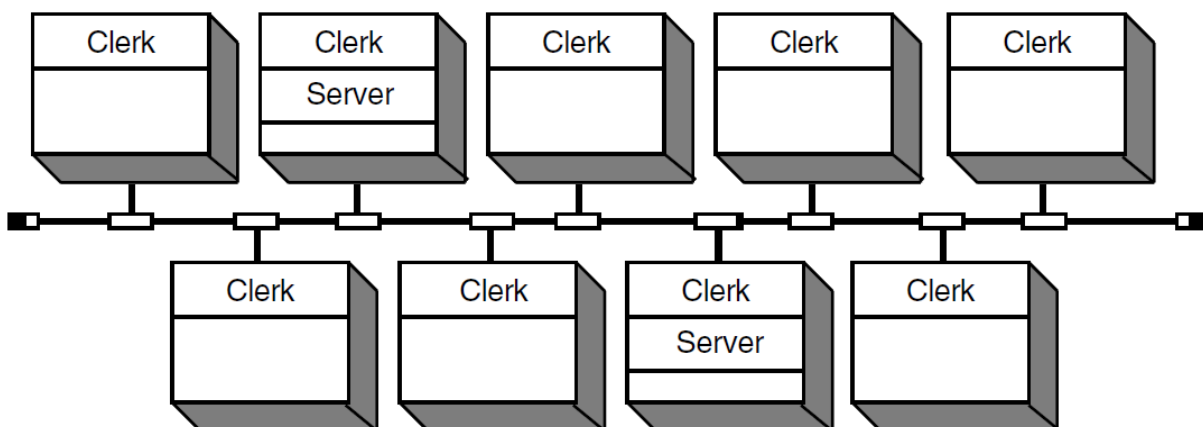

ZK-1948A-GE

Every DECdns server has a database called a **clearinghouse** in which it stores names and other DECdns data. The clearinghouse is where a DECdns server adds, modifies, deletes, and retrieves data

on behalf of client applications. Although more than one clearinghouse can exist at a server node, VSI does not recommend it as a normal configuration because it degrades the performance of the server.

Figure 1.2 shows the interaction between a DECdns client, clerk, server, and clearinghouse during a simple lookup. First, the clerk receives the lookup request from the client application (step 1) and checks its cache. Not finding the name there, the clerk contacts the server on Node 2 (step 2). The server finds the name in its clearinghouse (steps 3 and 4) and returns the requested information over the network to the clerk (step 5), which passes it to the client application (step 6). The clerk also caches the information so it does not have to contact a server the next time a client requests a lookup of that same name.

Figure 1.2. Simple Lookup

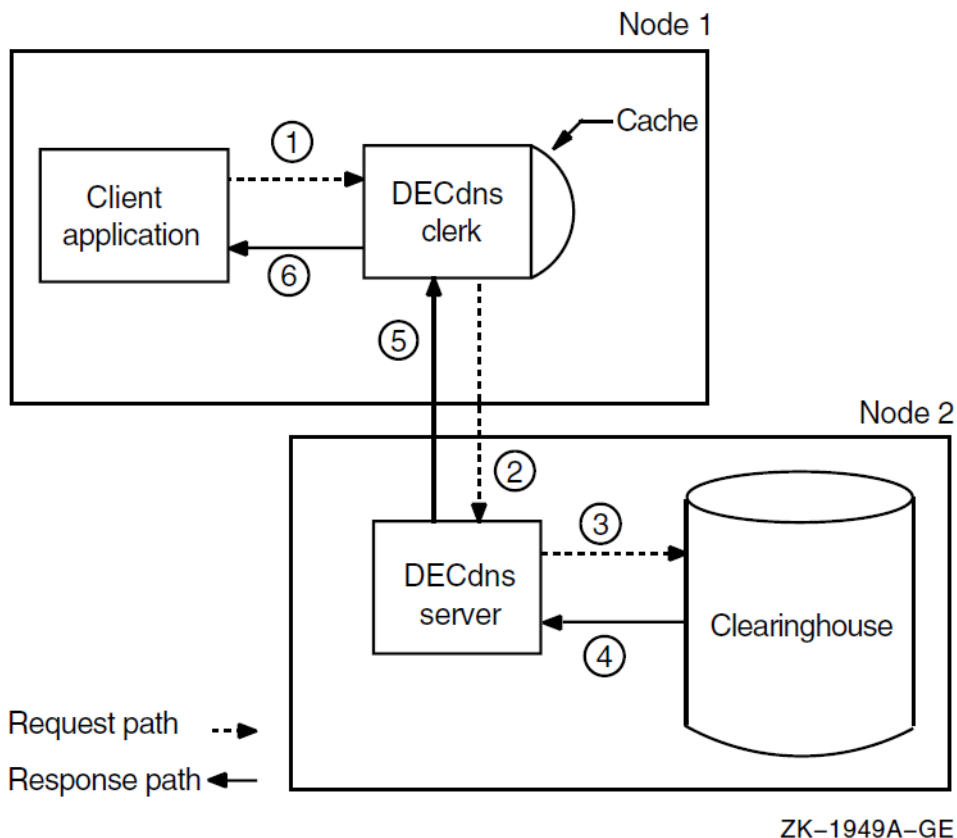

1.2. Examples of Client Applications that Use DECdns

One of the most important users of DECdns is DECnet Phase V software such as DECnet-Plus. When you make the transition from DECnet Phase IV to DECnet Phase V, all node names in your network become full names. If DECdns is used as the naming service, then all node names become DECdns full names. (For a discussion of full names, see Section 2.1.) Along with the node names, DECdns stores the address and protocol information that DECnet needs to make connections between nodes. The DECnet-Plus software includes a registration tool to help you create DECdns names for nodes.

Another important user of DECdns in DECnet-Plus software is the VSI Distributed Time Service (DECdts). DECdts and DECdns actually depend on each other. DECdts uses DECdns as a networkwide registry for global time servers that synchronize system clocks in the network. DECdns

uses timestamps to determine the order in which changes to its data occur, and it depends on DECdts to synchronize time on DECdns servers so their timestamps are consistent. Synchronized clocks are important to any distributed application that needs to keep track of the order in which events occur across multiple systems.

Two of the other OpenVMS applications that use DECdns (in conjunction with DECnet) are:

- VSI DECdfs for OpenVMS
- Notes for OpenVMS

VSI DECdfs for OpenVMS allows users on one OpenVMS system to access files on another system as if the files were on the local system. DECdfs uses DECdns to register file resources, called DECdfs access points.

VSI Notes is a computer conferencing system that lets you conduct online conferences or meetings. It uses DECdns to store the location (node name or address) of a conference. If a conference moves from one node to another, its moderator can update the address information stored in DECdns. Users can continue to refer to the conference by the same DECdns name and never need to know that it has moved to another node.

If you have VSI software that uses DECdns, read the documentation for that software for a further understanding of how it interacts with DECdns.

1.3. How People Use DECdns

Other than DECdns managers, the people who use DECdns do so only indirectly—through a client application's interface. A client application is normally the only direct user of DECdns. It interacts with DECdns on behalf of people who create a DECdns name for a resource and subsequently refer to it by that name. Some examples of people using DECdns follow:

- A user who copies a file from one node to another and includes DECdns node names in the command is using DECdns, indirectly through DECnet-Plus.
- A user who includes a DECdns node name in a mail address is using DECdns through the system's mail utility.
- A user who opens a VSI Notes conference entry with a DECdns name is using DECdns through the Notes application.
- A DECdfs manager who defines an access point (such as a disk) and gives it a DECdns name is using DECdns through the DECdfs control program. Any user who subsequently mounts the access point by referring to that name is a DECdns user.

1.4. What's in a Namespace?

The previous sections introduced a variety of ways in which applications and people can use DECdns names. This section describes basic concepts related to organizing and managing those names.

The total collection of names that one or more DECdns servers know about, look up, manage, and share is called a **namespace**. A DECdns namespace can be stored as a partitioned, partially replicated database. As a *partitioned* database, it is stored in several locations. As a *partially replicated* database, part of it is stored simultaneously in multiple locations.

When you create a namespace, you organize DECdns names into a hierarchical structure of **directories**. DECdns directories are conceptually similar to the directories you create in your operating system's file system. They are a logical way to group names for DECdns-specific management or usage purposes. **Directory replicas** are physical instances of a directory, stored in clearinghouses. In this way, a clearinghouse can be defined as a collection of directory replicas stored on a particular server. (A clearinghouse does not necessarily contain the entire namespace.)

The highest-level directory in the namespace is denoted by a dot (.) and is called the **root** directory. The root is created automatically when you initialize a namespace. You can then create and name other directories below the root. Any directory that has a directory beneath it is considered the **parent** of that directory. Any directory that has a directory above it is considered a **child** of the directory above it.

Figure 1.3 shows a simple hierarchy of directories. The root directory (.) is the parent of the directories named West and FarEast. The FarEast directory is a child of the root directory and the parent of the Tokyo and Osaka directories.

Figure 1.3. Sample Namespace Directory Hierarchy

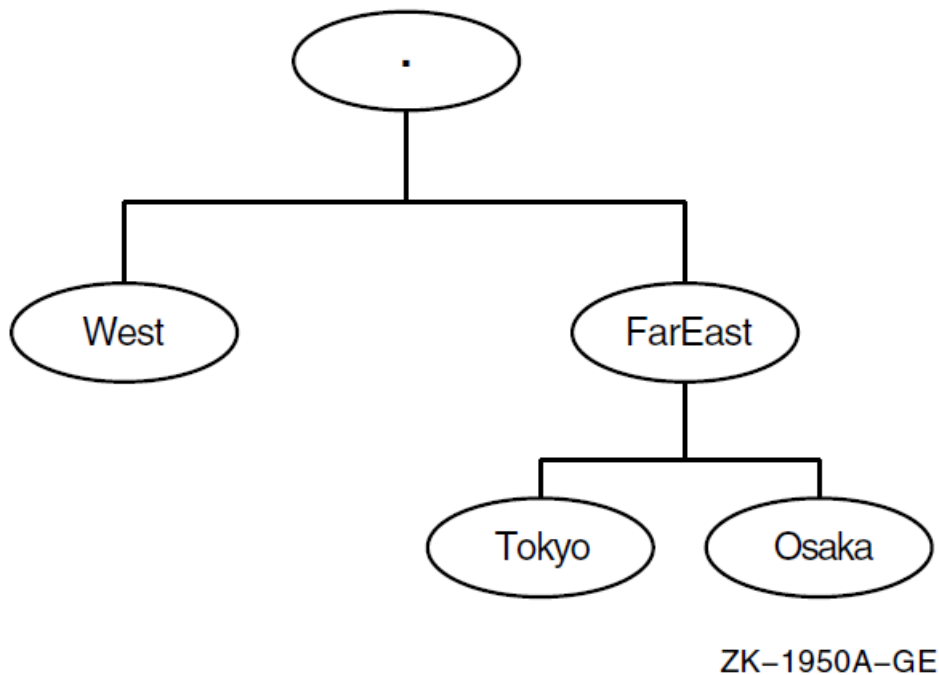

If you have a small network and do not expect much growth, you need a minimum number of directory levels in the namespace. For administrators of large networks, multiple directory levels provide greater flexibility in distributing, controlling access to, and managing many names. Distribution of names helps to balance the work load on DECdns servers.

1.4.1. Replicas and Their Contents

Directory replicas are the units by which you distribute names in clearinghouses throughout the namespace. You can think of a clearinghouse as a collection of directory replicas at a particular server. After you create a directory in one clearinghouse, you can create replicas of it in other clearinghouses.

All of the replicas of a specific directory in the namespace constitute that directory's **replica set**. DECdns ensures that all replicas of a directory remain consistent. See Chapter 3 for details on how this is done.

Two types of replicas can exist:

- Master
- Read-only

A replica's type affects the processing that can be done on it and the way DECdns updates it. The type of replica DECdns uses when it looks up or changes data is invisible to users. However, it helps to understand how the two types differ.

The **master replica** is the first instance of a specific directory in the namespace. After you make copies of the directory, you can designate a different replica as the master, if necessary, but only one master replica of each directory can exist at a time.

The master replica is the only directly modifiable replica of a directory. DECdns can create, change, and delete information in a master replica. Because it is directly modifiable, the master replica incurs more overhead than read-only replicas, which DECdns modifies using periodic updates.

A **read-only replica** is a copy of a directory that is available only for looking up information. DECdns does not create, modify, or delete names in read-only replicas; it simply updates them with changes made to the master replica. Read-only replicas save resources because DECdns does not make changes in them, except for periodic updates, nor does it have to gather changes from them to disseminate to other replicas.

Directory replicas can contain three kinds of entries:

- Object entries
- Soft links
- Child pointers

1.4.1.1. Object Entries

An **object** is any real-world network resource—such as a disk, application, or node—that is given a DECdns name. When an object name is created, client applications and the DECdns software supply attributes to be stored with the name. The name and its attributes make up the **object entry**. When a client application requests a lookup of the name, DECdns returns the value of the relevant attribute or attributes.

Every object has a defined class, which is stored as an attribute of the object entry. Programmers who write applications to use DECdns can define their own object classes and supply **class-specific attributes** for the name service to store on behalf of the application. Class-specific attributes have meaning only to the particular class of objects with which they are associated.

Two classes of objects are predefined by DECdns:

- Group
- Clearinghouse object entry

Groups let you associate, or manage as a group, names that have something in common. They do this by mapping a specific name (the group name) to a set of names, denoting the group members. DECdns managers can create groups that assign several users a single set of access rights to names.

Applications that use DECdns can create groups for purposes other than access control. This manual discusses groups only in the context of DECdns access control.

The **clearinghouse object entry** serves as a pointer to the location of an actual clearinghouse in the network. DECdns needs this pointer so it can look up and update data in a clearinghouse.

When you create a clearinghouse, DECdns creates its clearinghouse object entry automatically. The object entry acquires the same name as the clearinghouse. The clearinghouse object entry is like any other object entry in that it describes a network resource, but it is different because it is solely for internal use by DECdns. DECdns itself updates and manages clearinghouse object entries when necessary.

1.4.1.2. Soft Links

A **soft link** is a pointer that provides an alternate name for an object entry, directory, or other soft link in the namespace. You can restructure a namespace on a minor scale by creating soft links that point from an existing name to a new name. Soft links also can be a way to give something multiple names, so different kinds of users can refer to a name in a way that makes the most sense to them.

Soft links can be permanent, or they can expire after a period of time that you specify. If the name to which a soft link points is deleted, DECdns deletes the soft link automatically.

DECdns managers should use soft links carefully. They should not use soft links to completely redesign the namespace or to provide shortcuts for users who do not want to refer to the full name of an entry. Overuse of soft links makes DECdns names more difficult to track and manage. Section 9.1 provides more detail on soft links and how you can use and manage them.

1.4.1.3. Child Pointers

A child pointer connects a directory to another directory immediately beneath it in a namespace. Users and applications do not create or manage child pointers; DECdns creates a child pointer automatically when someone creates a new directory. DECdns uses child pointers to locate directory replicas when it is trying to find a name in the namespace. Child pointers do not require management except in rare problem-solving situations.

1.4.2. Putting It All Together

To summarize, a namespace consists of a complete set of names shared and managed by one or more DECdns servers. A name can designate a directory, object entry, or soft link. The logical picture of a namespace is a hierarchical structure of directories and the names they contain. Every physical instance of a directory is called a replica. Names are physically stored in replicas, and replicas are stored in clearinghouses. Any node that contains a clearinghouse and runs DECdns server software is a server.

Figure 1.4 shows the components of a DECdns server. Every server manages at least one clearinghouse containing directory replicas. A replica can contain object entries, soft links, and child pointers. Figure 1.4 shows only one replica and one of each type of entry possible in a replica. Normally, a clearinghouse contains many replicas, and a replica contains many entries.

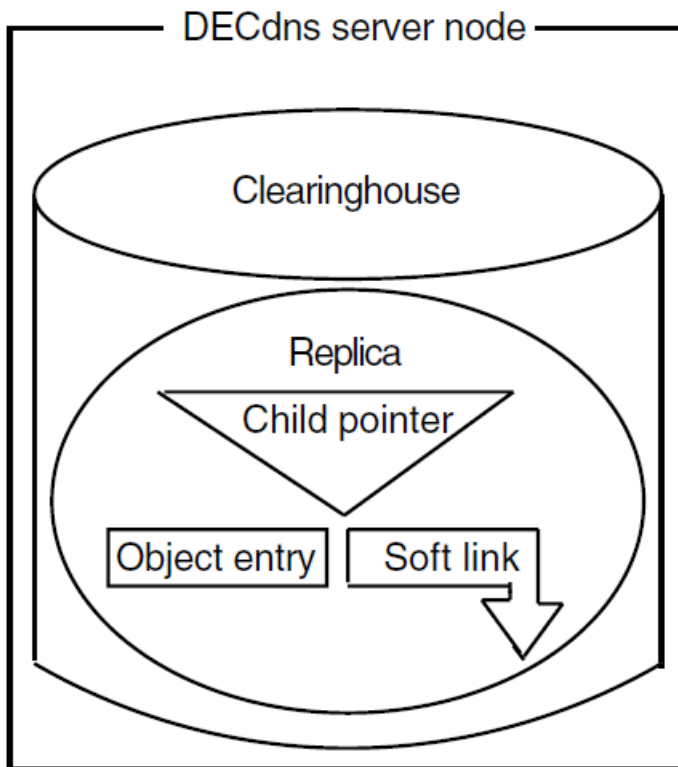
Figure 1.4. Components of a DECdns Server Node

ZK-1951A-GE

1.5. How DECdns Protects Names

DECdns lets you control access to clearinghouses, directories, and their contents. Access to clerks and servers is determined by operating system rights identifiers.

The DECdns access rights are read, write, delete, test, and control. Each access right has a slightly different meaning, depending on the kind of name with which it is associated. In general, the meanings are as follows:

- Read access lets users view data.
- Write access lets users change data.
- Delete access lets users remove data.
- Test access lets users test whether an attribute of a name has a specific value without being able to see any values (that is, without having read access to the name). This access right's main advantage is that it gives application programmers a more efficient way to read a value. Rather than reading a whole set of values, the application can test for a particular value. DECdns itself uses test access internally to test for group membership during access checking.
- Control access lets users change the access control on a name and grants other powers normally given only to an owner, such as the right to replicate a directory or relocate a clearinghouse.

You assign access in the form of an **access control entry** (ACE), which consists of two parts: the **principal** portion and the list of access rights that the principal has to the associated name in the

namespace. The principal part of the ACE can be the name of an individual user, a name with one or more wildcard characters to denote several users, or a group name.

A name can have multiple ACEs associated with it. The complete set of ACEs for a particular name is called an **access control set** (ACS), and is an attribute of that name.

Note

The access control provided by DECdns applies only to DECdns names, not the physical resources they describe. Traditional methods of access control are still necessary to protect the resources described by the object entries in a namespace.

It is often useful to set up an access control policy when you plan your namespace, choosing a select group of users who will have control over the root of the namespace and deciding how to delegate access in lower levels of the directory structure. Section 5.3 provides guidelines for planning an access control policy for your namespace.

1.6. Available Management Tools

DECdns provides a control program for entering commands to manage and display the namespace (see Section 1.6.1). In addition, other support tools include:

- The DECdns configuration program (see Chapter 10) – Allows you to modify the namespace, change a clerk's default namespace, configure a DECdns server in an existing namespace and so forth.
- The `decnet_register` tool (see the *VSI DECnet-Plus for OpenVMS Network Management Guide*) — Allows you to manage node information on your node.

1.6.1. DECdns Control Program

The DECdns Control Program (DNSCP) is an interface that accepts commands targeted for specific **entities**. It is available on all DECdns clerks and servers. The control program is patterned after the DECnet Phase V management interface Network Control Language (NCL), which defines an entity as any individually manageable part of the network or of an application in the network. Some DECdns entities can be managed from NCL as well as from DNSCP. The commands are the same from both interfaces; when DNSCP receives a command targeted for an NCL entity, it passes the command on to NCL.

The general distinction between NCL and DNSCP is physical management versus logical management. NCL commands allow you to manage the physical components of DECdns, such as the server and clerk. Thus, you can include startup and shutdown commands for these components in NCL scripts. The DNSCP commands manage primarily the logical parts of a namespace, such as directories and the names they contain.

You can manage the following DECdns entities with either NCL or DNSCP:

- `dns clerk`
- `dns clerk known namespace`
- `dns clerk manual name server`
- `DNS clerk remote clearinghouse`

- `dns server`
- `dns server clearinghouse`

You can manage the following DECdns entities only from DNSCP:

- Child
- Clearinghouse
- Directory
- Group
- Link
- Object
- Replica
- Subtree

See Chapter 4 for details on how to use DNSCP and an explanation of each of the entities.

1.7. Management Tasks

DECdns requires advance planning and, once the namespace has been established, ongoing maintenance. For detailed planning guidelines, see the *VSI DECnet-Plus Planning Guide*. This section describes the routine DECdns ongoing management tasks.

DECdns management tasks fall into two main categories: namespace administration and day-to-day server management. In small networks, it is possible for one person to handle both types of tasks. In larger networks, the responsibility will most likely be divided among several people.

The following are some common tasks of a namespace administrator:

- Oversee the creation of new directories and assign names according to a standard, or enforce established guidelines in assigning and controlling access to names. (Beyond a certain directory level, the namespace administrator might delegate the responsibility of creating and maintaining directories to a server manager. The administrator should still keep track of the new directories being created to make sure they are appropriately replicated.)
- Along with server managers, monitor the size and usage of clearinghouses and determine the need for new DECdns servers and clearinghouses. Plan and oversee the configuration of these new servers and clearinghouses.
- Determine where and when new replicas of a directory are necessary.
- Use the DECdns Control Program to monitor namespace directories and their contents. Determine the need for new directories under the root.
- Create soft links for object entries whose names change or for entries that people can refer to by more than one name. Publicize and encourage use of the new names so that eventually the soft links can expire and be deleted.
- Solve or direct the resolution of problems involving multiple DECdns servers.

The following are some common tasks of a DECdns server manager:

- Enable event logging, monitor DECdns events, and solve system-specific problems if they arise. If necessary, notify the namespace administrator of problems that could affect other DECdns servers or clerks.
- Monitor the success of skulks that originate at the server. This task is the most important maintenance procedure.
- Monitor the size and usage of the server's clearinghouse and, if necessary, discuss with the namespace administrator the need to relocate some replicas or create a new clearinghouse.
- Monitor and tune system parameters that affect or are affected by DECdns server operation.

Chapter 2. How DECdns Looks Up Names

This chapter describes the structure of DECdns names, illustrates the relationship between a name and the physical resource it describes, and explains how DECdns handles requests to look up names. It also explains how to create short forms of long DECdns names. Understanding these concepts can help you plan the location of clearinghouses and directories in your namespace. It can also help you isolate the source of problems if you encounter lookup errors or failures.

2.1. Structure of a Name

The complete specification of a name in the namespace is called its **full name** and includes the names of all of its parent directories, starting from the root. Each element within a full name is separated by a dot (.) and is known as a **simple name**.

A full name also can include a namespace nickname, but that is not necessary when only one namespace exists in a network. A namespace administrator or system manager defines the default namespace during configuration of a DECdns clerk, or later by a management command. Then, unless a user specifies otherwise, DECdns always assumes a name is in the default namespace. If it is necessary to specify a namespace, use the following format:

```
namespace_nickname:.simplename.simplename...
```

For example, `ABC:.Dir1` specifies a directory called `.Dir1` in the `ABC` namespace. Similarly, `JKL:.Dir1.Object` denotes an object entry with the simple name `Object` in the `Dir1` directory and the `JKL` namespace.

2.2. Translating from Names to Resources

Just as directory names in a logical namespace hierarchy translate to physical replicas in clearinghouses, DECdns names translate to physical resources that are used either internally by DECdns or by client applications. The attributes of a name are what make the translation possible. This section illustrates the relationship between DECdns names and the physical resources they describe.

Figure 2.1 shows three directories and their contents in a logical namespace, and how replicas of those directories are physically implemented in two clearinghouses. The clearinghouses themselves have DECdns names: `.Boston_CH` on Node 1 and `.Sales.East.NY_CH` on Node 2. The `_CH` suffix is a recommended convention for naming clearinghouses. The `.Boston_CH` clearinghouse contains replicas of the root directory and the `.Sales.East` directory. The `.Sales.East.NY_CH` clearinghouse contains a replica of the `.Sales` directory. VSI recommends that you create at least two replicas of every directory. Therefore, each directory shown should be replicated in at least one other clearinghouse somewhere in the network.

Figure 2.1. Logical and Physical Views of a Namespace

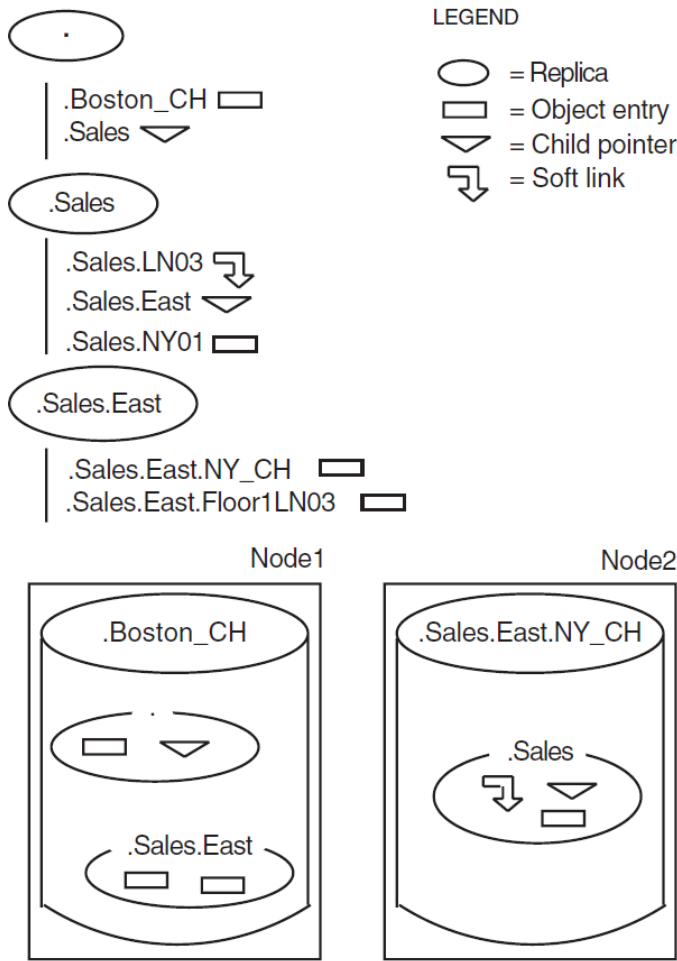

ZK-2044A-GE

To discover the physical location of a DECnet resource, for example, DECdns looks up an address associated with its node name. The next four figures illustrate the connection between various kinds of DECdns names and the resources they describe. The figures are based on the namespace in Figure 2.1.

Figure 2.2 shows the relationship between an object entry named `.Sales.NY01` and the resource it describes: a node at the organization's New York sales headquarters. The node object entry resides in a replica of the `.Sales` directory in the `.Sales.East.NY_CH` clearinghouse. The entry has a `DNA$Towers` attribute, which contains protocol and address information necessary to contact the node. The name of this attribute reflects the fact that a DECnet Phase V address consists of separate layers, sometimes called tower floors, in the Network Architecture (DNA) and Open Systems Interconnection (OSI) models.

Figure 2.2. A Node Object Entry and a Node

Figure 2.3 shows the relationship between two clearinghouse object entries and the clearinghouses they describe. A clearinghouse object entry differs from other kinds of object entries in that it is created and maintained by the DECdns software instead of by a client application, and special rules exist regarding where it can be stored (see Appendix B for details). However, it is just like any other object entry in that it describes a physical resource in the network: the clearinghouse. The clearinghouse and its object entry both have the same name; DECdns creates the object entry automatically when you create and name the clearinghouse.

The figure shows two clearinghouse object entries: `.Boston_CH`, which points to the clearinghouse named `.Boston_CH` on Node 1, and `.Sales.East.NY_CH`, which points to the clearinghouse named `.Sales.East.NY_CH` on Node 2. Each clearinghouse object entry has a `DNA$Towers` attribute that contains, among other things, the DECnet address of the node where the clearinghouse resides. As the figure shows, it is not necessary for the clearinghouse object entry to be stored within the clearinghouse to which it points.

Figure 2.3. Clearinghouse Object Entries and Clearinghouses

Figure 2.4 shows the relationship between a soft link, the object entry it points to, and the resource that the object entry describes. The link, `.Sales.LN03`, has an attribute called `DNS$LinkTarget`, which contains the name that the link points to: an object entry named `.Sales.East.Floor1LN03`. The object entry describes an LN03 printer on the first floor of the company's New York sales office. A replica containing the `.Sales.East.Floor1LN03` object entry exists in the `.Boston_CH` clearinghouse. The entry has an attribute that contains information on how to locate the printer in the network.

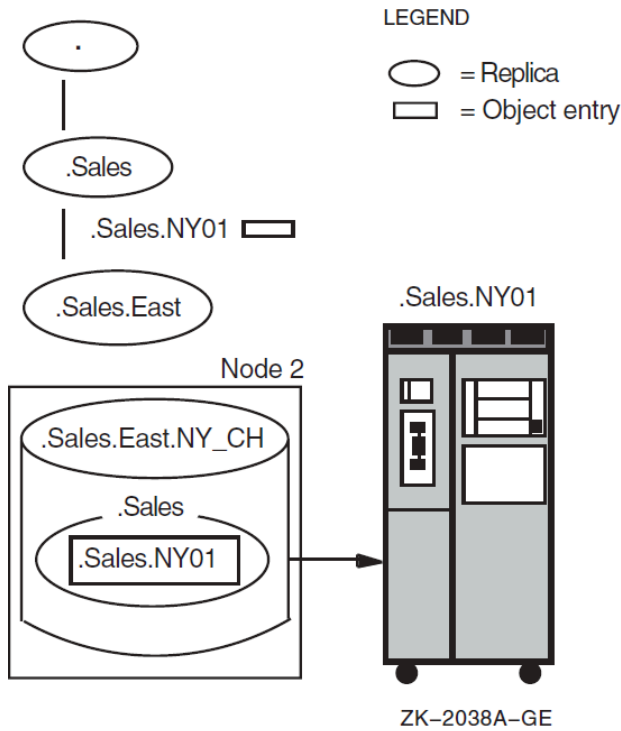
Figure 2.4. A Soft Link and Its Resolution

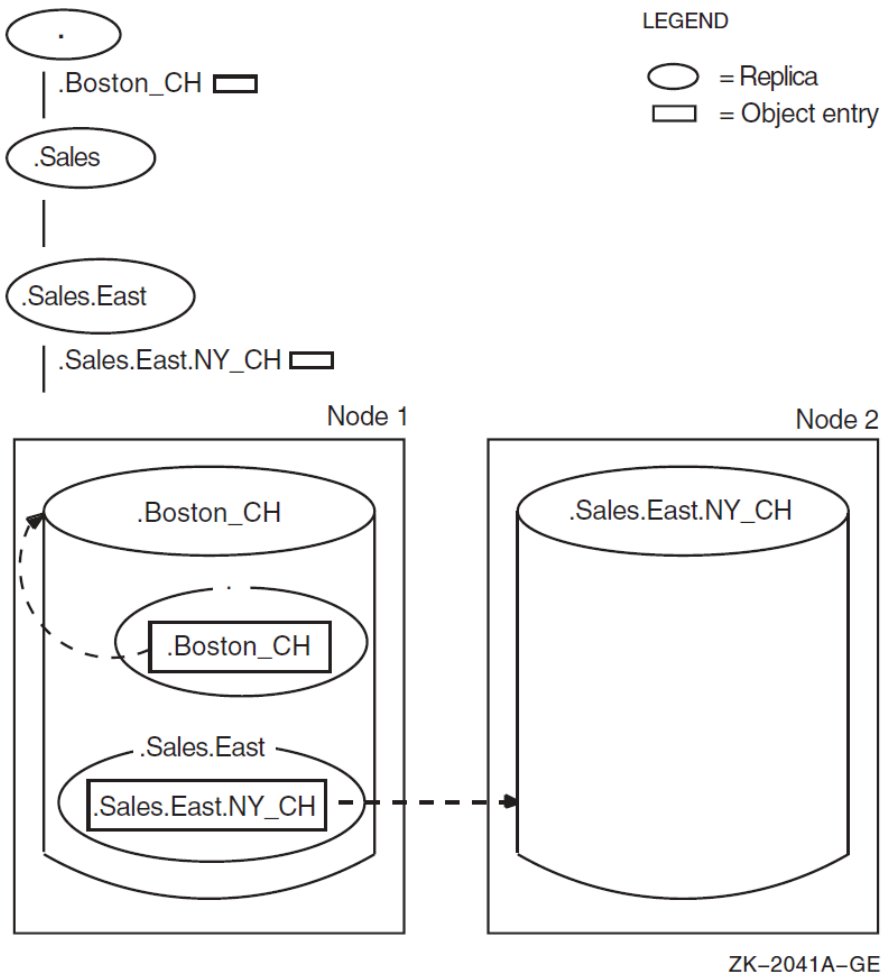
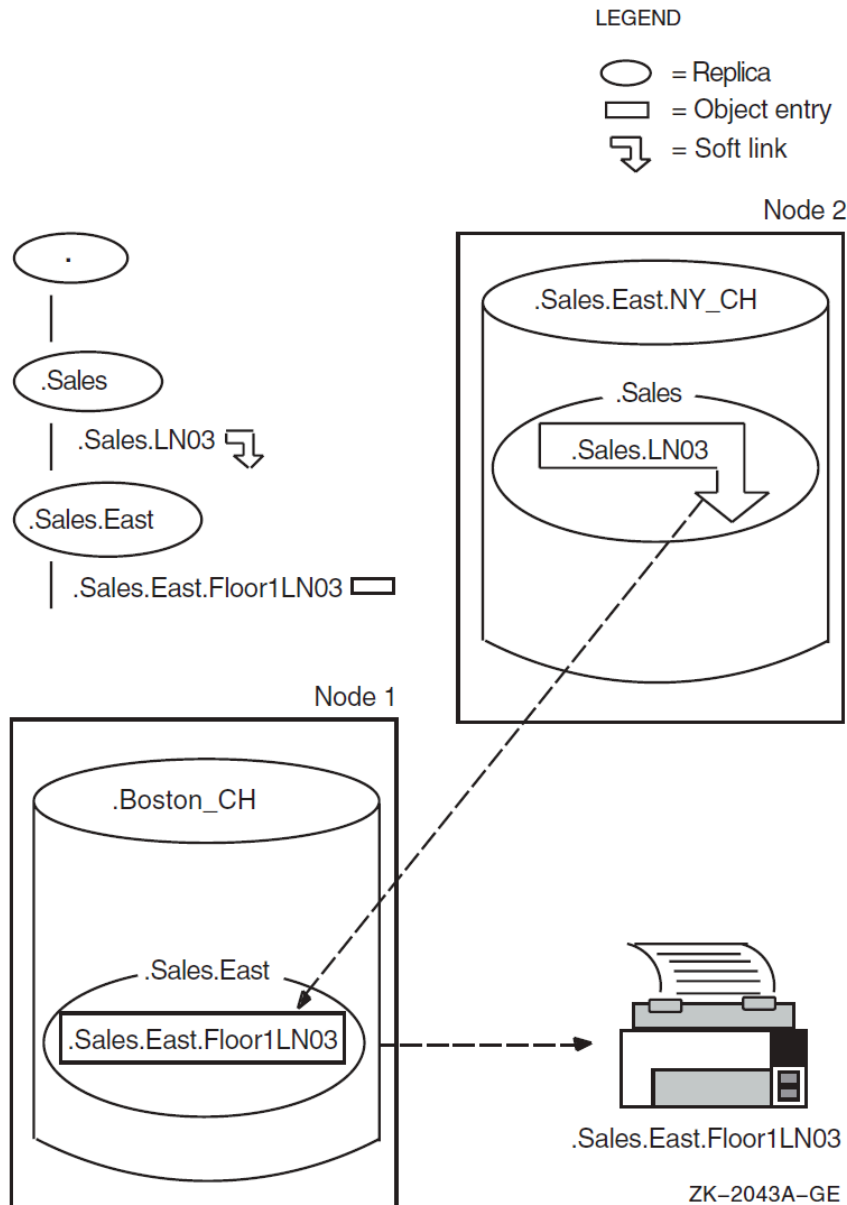
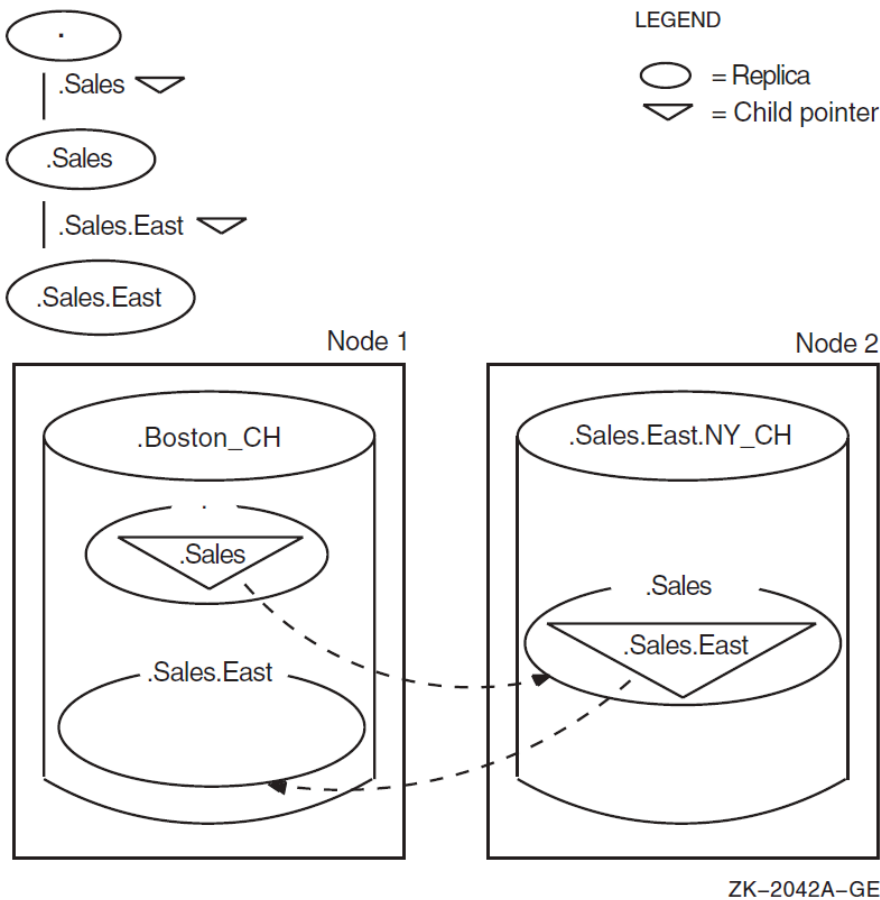

Figure 2.5 shows the relationship between directories and their associated child pointers. It illustrates that, although a child pointer has the same name as its associated directory, the pointer is a separate entry in the namespace and resides in the parent of the directory to which it points.

In the `.Boston_CH` clearinghouse, the root replica contains a child pointer for the `.Sales` directory. The child pointer has an attribute called `DNS$Replicas` that contains the name and address of the `Sales.East.NY_CH` clearinghouse, where a replica of the `.Sales` directory exists.

In the `.Sales.East.NY_CH` clearinghouse, the `.Sales` replica contains a child pointer for the `.Sales.East` directory. The child pointer's `DNS$Replicas` attribute contains the name and address of the `.Boston_CH` clearinghouse, where a replica of the `.Sales.East` directory exists.

When a directory has multiple replicas, as would normally be the case, the `DNS$Replicas` attribute lists all of the clearinghouses containing a replica of that directory.

Figure 2.5. Child Pointers and Directories

2.3. Resolving Names and Addresses with the Naming Cache

DECnet-Plus software includes the common directory interface (CDI) which acts as an interface between DECnet Phase V Session Control and all the supported name services (Local namespace, DECdns, DNS/BIND). CDI performs the necessary switching between the various name services during lookups, enabling the use of multiple name services. CDI uses an in-memory naming cache to improve performance of name and address resolution for the supported name services.

Previous to the addition of the CDI, the DECdns clerk was the primary interface between DECnet Phase V Session Control and DECdns servers or the Local namespace. Now most all DECnet-related calls to DECdns (or to any other name service) are first handled by CDI.

The DECdns clerk receives requests for name/address information from client applications and looks up the requested information on the appropriate DECdns server or in the Local namespace. The DECdns clerk caches (saves) pointers to DECdns servers discovered during these lookups. For lookups involving applications such as DECmcc and DFS, the DECdns clerk caches results of lookups. This saves the clerk from repeatedly connecting to a server for the same information. Caching improves performance and reduces network traffic.

The DECdns clerk cache still exists. When CDI calls DECdns for node name information, DECdns searches the clerk cache to determine where to look up the requested information. DECdns continues to use the clerk cache to determine the location of servers in the DECdns namespace. DECnet-Plus for

OpenVMS uses the DECdns clerk to parse the special namespace nicknames LOCAL: and DOMAIN:. These nicknames in a node full name indicate to DECnet-Plus the name service where the name and addressing information is stored. Note that DECdns clerks do not cache DECnet names for any namespace. The clerk caches pointers to the servers where node names are stored.

The DECdns clerk cache continues to be used by applications other than DECnet-Plus that use DECdns directly, such as the DECdfs application.

Using NCL commands, you can manage two CDI naming cache parameters: the checkpoint interval and the timeout period, and you can flush entries from the in-memory naming cache. These parameters control CDI; they do not control DECdns. For more information on managing CDI, see the *VSI DECnet-Plus for OpenVMS Network Management Guide*.

2.4. How DECdns Finds Names

As the previous figures illustrate, DECdns finds information about the physical location of a resource by looking up one or more attributes associated with its name. First, though, the clerk must know how to find the name. If a name does not yet exist in the clerk's cache, the clerk must know of at least one DECdns server to contact in search of the name.

The clerk can learn about servers and their locations in any of three ways:

- During configuration

A system manager either supplies or selects the address of at least one server during clerk configuration.

- Through the **solicitation and advertisement protocol**

Clerks and servers on the same local area network (LAN) communicate using the solicitation and advertisement protocol. A server transmits messages at regular intervals to advertise its existence to clerks on its LAN. The advertisement message contains data about the namespace that the server belongs to, the server's network address, and the clearinghouse it manages. Clerks learn about servers by listening for these advertisements on the LAN. A clerk also sends out solicitation messages (which request advertisements) at startup and when it encounters a namespace nickname that it does not have in its cache.

- During a lookup

During a lookup, if a clearinghouse does not contain a name that the clerk is searching for, the server managing that clearinghouse gives the clerk as much data as it can about where else to search for the name. This information can come from two sources:

- The contents of a clearinghouse attribute called **DNS\$CHUPointers**

If a clearinghouse does not contain any replicas that are part of the full name being looked up, the server returns a list of clearinghouses that helps the clerk search closer to the root for replicas relevant to the name. The server keeps the list in a clearinghouse attribute called `DNS$CHUPointers`. The attribute contains the names of clearinghouses that store either a root replica or replicas closer to the root than the replicas in that server's own clearinghouse.

- The contents of a child pointer attribute called **DNS\$Replicas**

If a clearinghouse contains replicas that are part of the full name being looked up, but not the replica containing the target simple name, it returns data from a relevant child pointer in the

replica it has. The data helps the clerk find the next child directory in the path toward the target simple name. The child pointer's `DNS$Replicas` attribute contains this data.

Figure 2.6 is an example of how the clerk finds the root and works downward from it to locate an object entry. The entry, `.Sales.RSMcl`, describes a client system at a company's London sales headquarters.

Figure 2.6. How the Clerk Finds a Name

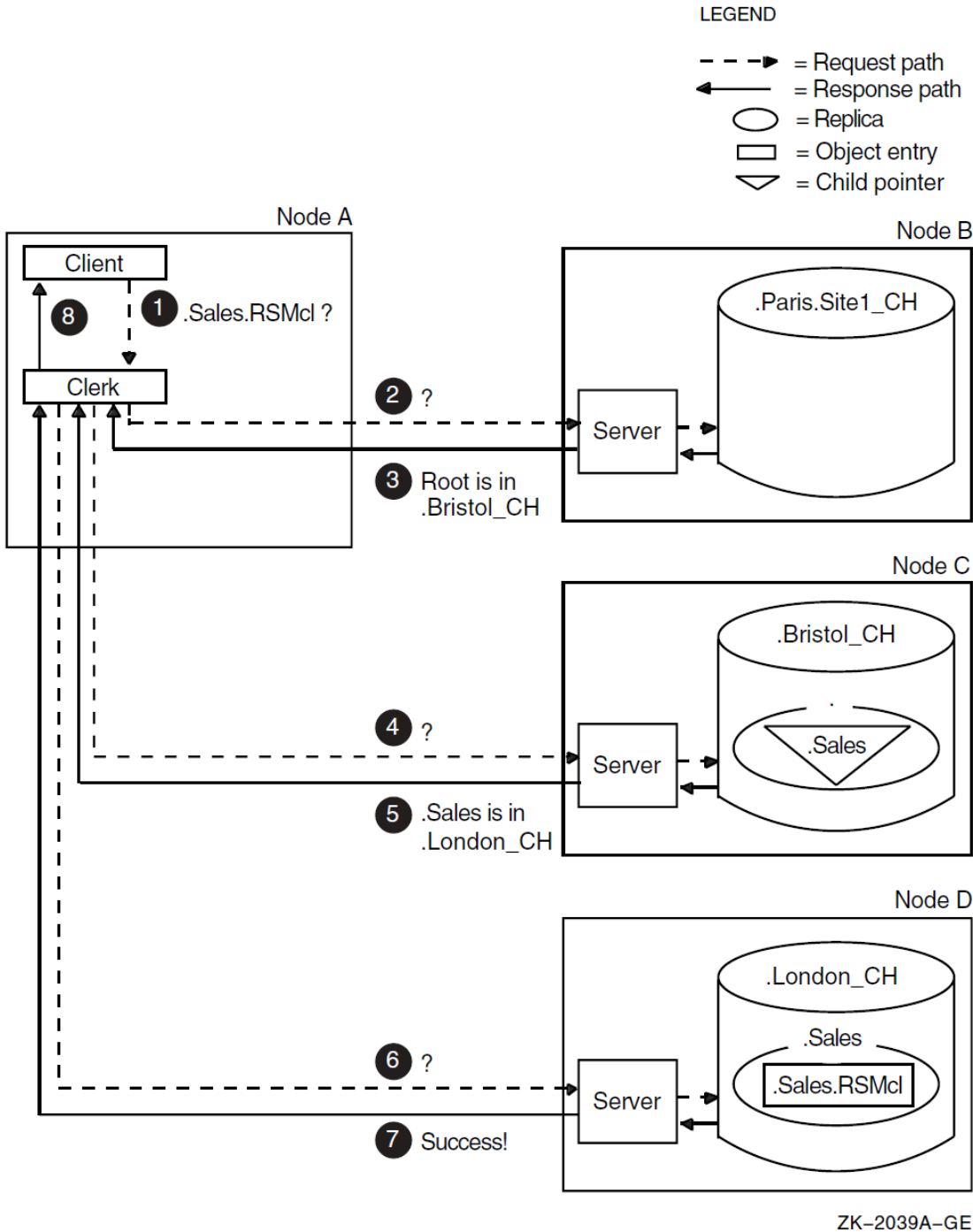

1. On Node A, a client application requests the address of the `.Sales.RSMcl` object entry. The clerk does not have that name in its cache, and the only clearinghouse it knows about so far is `.Paris.Site1_CH` on Node B.

2. The clerk contacts the server on Node B with the lookup request.
3. The `.Paris.Site1_CH` clearinghouse contains no replicas relevant to the target name. However, its `DNS$CHUPPointers` attribute contains the name and address of the `.Bristol_CH` clearinghouse, which stores a replica of the root. Starting from the root, the clerk will be able to find directories that are part of the name even if the `.Bristol_CH` clearinghouse does not contain the target name itself. The server on Node B sends the requesting clerk the name and address of the `.Bristol_CH` clearinghouse on Node C.
4. The clerk contacts the server on Node C with the lookup request.
5. The `.Bristol_CH` clearinghouse does not contain the target object entry, but from the `.Sales` child pointer in the root, the clerk can learn the names and addresses of clearinghouses that have a replica of the `.Sales` directory. The server on Node C returns this data to the clerk, informing it that a replica of the `.Sales` directory is in clearinghouse `.London_CH` on Node D.
6. The clerk contacts the server on Node D with the lookup request.
7. The `.Sales` replica in the clearinghouse on Node D contains the `.Sales.RSMcl` object entry, so the server passes the contents of the entry's address attribute to the clerk.
8. The clerk returns the address to the client application. The application can now locate the client system in the network.

Long lookups like the one illustrated in Figure 2.6 should not happen often after a clerk establishes its cache and becomes more knowledgeable about servers and their contents. The figure illustrates the resources and connections that could be involved in an initial lookup—the clerk contacted three servers before it found the information it needed. The figure also illustrates the important job DECdns has of making sure the parent and child directories in the namespace remain connected. If the directory path is broken or a clearinghouse is unreachable, a clerk might not be able to complete a lookup. Keep this example in mind when planning the replication of directories.

2.5. Short Forms of DECdns Names

Because a full name consists of the complete directory path from the root directory to the target object entry, directory, or soft link, full names can be long if a namespace has several levels of directories.

DECnet Phase V software supports a form of abbreviated name called the **node synonym**. A node synonym is a soft link that points to the full name of a node object entry. Node synonym soft links, in the form of a DECnet Phase IV-style node name, enable applications that do not support the length of DECdns full names to continue to use six-character node names.

Node synonyms should not be viewed as a way for users to avoid typing the DECdns full name of a node. Local names, and a feature called the **local root**, are a faster and more convenient method of shortening names. Both local names and local roots are for use only on the system where they are defined; unlike node synonyms, they do not have global meaning throughout the namespace. Local names and local roots are usable for any DECdns name, not just node names. However, they are not usable for DECnet node name lookups; they are used for DECdns Control Program lookups and lookups for applications other than DECnet.

2.5.1. How Node Synonyms Work

A node synonym is optional; the system manager can supply it during configuration of the DECnet-Plus software. DECnet-Plus systems store node synonyms in a DECdns directory called **.DNA_NodeSynonym**.

When DECnet Phase V Session Control receives a node name of six alphanumeric characters or fewer (one alphabetic character minimum) that does not contain a leading dot, it first uses local name mapping with CDI to resolve the name. If that method fails, Session Control tries to look up the name in the Session Control node synonym directory, which is typically `.DNA_NodeSynonym`. Suppose, for example, DECnet is given the node name `MIS01`. Session Control sends a request to DECdns to look up `.DNA_NodeSynonym.MIS01`. The node synonym exists and points to the full name of the node, `ABC: .Geneva.Admin.MIS01`.

If a node synonym does not exist, DECnet asks the DECdns clerk to determine the full name. The clerk uses the name abbreviation methods described in Section 2.5.2.

2.5.2. Name Abbreviation Methods

The DECdns clerk uses local name resolution methods when it encounters any abbreviated name; that is, a name that does not start with a namespace nickname or a dot. The method by which DECdns clerks interpret abbreviated names varies by operating system.

Local name mapping is accomplished with logical names. When the DECdns clerk is started, the system creates a unique logical name table called `DNS$SYSTEM`. This unique table prevents unintended interaction with other system logical names. To define a systemwide logical name for a DECdns full name, enter a DCL command in the following format:

```
$ define/table=dns$system name1 "name2"
```

where *name1* is the abbreviated name that a user can enter, and *name2* is the name to be substituted for it in the process of translation to a full name. *Name2* can be either a DECdns full name or another shortened name.

2.5.3. Local Root

The local root is a prefix that DECnet Phase V software obtains automatically by stripping off the rightmost simple name of the local node's full name. For example, a node named `IAF: .Dist.QA01` would have `IAF: .Dist` as its local root. Users will likely want to refer frequently to other names in the hierarchy in which their local node is named. The local root capability makes such name references more convenient by allowing users to omit the part of the full name that is also part of their node's full name.

DECnet Phase V Session Control creates the local root under the fixed name `dnsroot` in the `DNS$SYSTEM` logical name table.

2.5.4. How Local Name Substitution Works

When the DECdns clerk encounters a name with no leading dot or namespace nickname, it uses the following procedure to obtain a full name:

1. The clerk first attempts to translate the leading (leftmost) simple name by using the local name-mapping file. If it finds a translation in the file, the clerk replaces the leading simple name with the result of the translation. This process is repeated until there is no local mapping for the leading simple name, or until the translation results in either a namespace nickname or a leading dot.
2. If the clerk does not find a local name-mapping, and the name is still abbreviated, the clerk next attaches the local root to the front of the name to create a full name.
3. If no local root exists, the clerk attaches a leading dot to the front of the name to create a full name.

4. Once the clerk obtains a full name, it attempts the requested operation on that name. If the name does not exist, DECdns returns an error.

The following is an example of how DECdns would use a local name-mapping file to translate the name `Sales.Forecasts`.

1. DECdns searches the local name-mapping file for a match for `Sales`.
2. The name `Sales` exists in the file and maps to the name `IAF:.Sales.East.Region3`, so the name the user entered expands to `IAF:.Sales.East.Region3.Forecasts`.

The following is an example of how DECdns would use a local root to translate the name `Support_disk`, entered by a user on node `.Eng.Vega` in the IAF namespace:

1. DECdns searches the local name-mapping file for the name `Support_disk`.
2. Not finding a match in the local name file, DECdns attaches the local root, `IAF:.Eng`, to the front of the name, resulting in the full name `IAF:.Eng.Support_disk`.

The following example shows how DECdns would use both a local name-mapping file and a local root to translate the name `RSM_client`, entered by a user on node `.Sales.Monet` in the IAF namespace:

1. DECdns searches the local name-mapping file for the name `RSM_client`.
2. The name `RSM_client` exists in the file and maps to `Personnel.RSM_client`, so the name the user entered expands to `Personnel.RSM_client`.
3. Because the expanded name still does not include a leading dot or namespace nickname, DECdns searches the file for `Personnel`.
4. DECdns does not find `Personnel` in the local name mapping file, so it attaches the local root, `IAF:.Sales`, to the front of the name, resulting in the full name `IAF:.Sales.Personnel.RSM_client`.

Chapter 3. How DECDns Updates Data

Once names exist in the namespace, users who have the appropriate access can make changes to the data associated with them. Any addition, modification, or deletion of DECDns data initially happens in only one replica: the master replica. This chapter introduces the main methods by which DECDns keeps other replicas consistent: **update propagation** and the **skulk** operation. It also describes two timestamps that help ensure consistency in DECDns data. By understanding the concepts in this chapter, you can more effectively plan the content and replication of directories in your namespace.

3.1. Update Propagation

An update propagation is an immediate attempt to apply one change to all replicas of the directory in which the change was just made. Its main benefit is that it delivers each change in an efficient and timely way. Unlike a skulk operation, however, update propagation does not guarantee that the change gets made in all replicas. If a particular replica is not available, the update propagation does not fail; the change simply does not get made in that replica. The skulk operation ensures that when the replica is available again, it becomes consistent with the other replicas in its set.

You can tune the degree of persistence that DECDns uses in attempting an update propagation—or prevent propagation altogether—by adjusting a directory attribute called **DNS\$Convergence**. Convergence also affects the frequency of skulks on a directory. See Section 7.5 for details on viewing and changing a directory's convergence.

3.2. Skulk Operation

The skulk operation is a periodic distribution of a collection of updates. Its main function is to ensure that replicas receive changes that might not have reached them during an update propagation. It also cleans outdated information out of the namespace. These maintenance functions include:

- Removing soft links that have expired (you can specify an expiration time when you create a soft link).
- Maintaining child pointers, which includes removing pointers to directories that were deleted.
- Removing information about deleted replicas.

DECDns skulks each directory individually. During a skulk, DECDns collects all changes made to the master replica since the last skulk completed and applies them to the replica on the server where the skulk started. DECDns then disseminates the changes from the up-to-date replica to all other replicas of the directory. All replicas must be available for a skulk to be considered successful. If DECDns cannot contact a replica, it continues making changes in the replicas that it can contact, and generates an event to notify you of the replica or replicas it could not update. DECDns then periodically reattempts the skulk until it completes successfully.

A skulk can begin in one of three ways:

- A DECDns manager can enter a command to start an immediate skulk on a directory.
- DECDns starts a skulk as an indirect result of other namespace management activities, which include:
 - Adding or removing a replica

- Creating or deleting a directory
- Creating a clearinghouse
- Redesignating replica types

All of these activities produce changes in the structure of the namespace, so an immediate skulk ensures that the new structure is reflected throughout the namespace as quickly as possible.

- The DECdns server initiates skulks automatically at a routine interval called the **background skulk time**.

The background skulk time guarantees a maximum lapse of time between skulks of a directory, regardless of other factors, such as namespace management activities and user-initiated skulks. Every 24 hours, a DECdns server checks each master replica in its clearinghouse and initiates a skulk if changes were made in a directory since the last time a skulk of that directory completed successfully.

3.3. How Timestamps Help Keep Data Consistent

DECdns uses several timestamps to help ensure the consistency and accuracy of data. The following two timestamps exist for every entry:

- Creation timestamp (CTS)
- Update timestamp (UTS)

DECdns assigns a **creation timestamp** (CTS) to everything within a namespace (clearinghouses, directories, object entries, soft links, and child pointers) as well as to the namespace itself. On the namespace, the timestamp is called a namespace creation timestamp (NSCTS).

The CTS is a unique value reflecting the date, time, and location where a namespace, clearinghouse, directory, or entry in a directory was created. It consists of two parts: a time portion and the system identifier of the node on which the name was created. The two parts guarantee uniqueness among timestamps generated on different nodes.

During propagation of a new name to each replica of the directory where it was created, every DECdns server checks the validity of the CTS before accepting the new name. A name's CTS is valid if it falls between the current time and the time of the last skulk on the directory where it was created. When determining the current time, the server allows a maximum acceptable time difference of 300 seconds into the future.

The **update timestamp** (UTS) reflects the most recent change made to any of the attributes of a clearinghouse, directory, object entry, soft link, or child pointer. When a DECdns server receives an update to an existing entry in a directory, it checks the validity of the UTS before accepting the update. Occasionally, between skulks or update propagations, separate changes may be made to the same attribute of the same entry in different replicas. In that case, the change with the most recent UTS remains.

Directories and replicas have several other timestamps that DECdns uses when determining whether to skulk a directory or make a change in a directory. Chapter 11 describes those timestamps and how DECdns uses them.

Chapter 4. Using the DECdns Control Program

This chapter introduces the DECdns Control Program (DNSCP). The control program is an interface with which you can manage the components of DECdns and the contents of the namespace.

To start the control program, enter the following command:

```
$ run sys$system:dns$control
```

To obtain online help while using DNSCP, enter the following command:

```
dns> help
```

To exit the control program, enter the following command:

```
dns> exit
```

4.1. Elements of a DECdns Command

All commands must include a verb, an entity name, and all required arguments. Depending on the command, you can also specify one or more optional arguments, attributes, or prepositional phrases. A comma must separate more than one attribute or argument, and a comma and a space must always precede a prepositional phrase. A DECdns command can contain the following elements, in the order shown:

```
verb [entity-name] [argument] [attribute] [, prepositional-phrase]
```

- **Verb** — A verb, or directive, denotes the action to be taken on the DECdns entity that you specify.
- **Entity name** — An entity name describes the DECdns entity on which the action specified by a command's directive is taken. See Section 4.6 for details on how to set a default entity.
- **Argument** — An argument affects the result of the action specified by a command's directive. Some arguments are required; others are optional.
- **Attribute** — An attribute is an element whose value (or values) describes a particular operational property of an entity and specifies other information that reflects the entity's behavior.
- **Prepositional phrase** — A prepositional phrase affects the destination or content of command output.

Refer to the command descriptions in Chapter 11 for complete listings of the arguments, attributes, and prepositional phrases you can use with a particular DECdns command.

You can enter commands that manage Network Control Language (NCL) entities from either NCL or DNSCP. You can abbreviate an NCL directive or entity name to a minimum of four unique characters. You can abbreviate a DNSCP directive or entity name to its fewest number of unique characters.

4.2. DECdns Entities

This section lists the DECdns entities and describes what each entity represents.

Child

A child pointer connects a parent and child directory in a hierarchical namespace. The child pointer is stored in the parent directory.

Clearinghouse

A clearinghouse is a database containing a collection of directory replicas at a particular server. Commands directed to this entity manage DECdns attributes of the clearinghouse (for example, its access control set). You can enter these commands only from DNSCP.

Directory

A directory contains object entries and other namespace entries that are logically stored under one name (the directory name).

DNS Clerk

The clerk is the interface between client applications and servers. You can enter commands directed to this entity from either NCL or DNSCP.

DNS Clerk Known Namespace

A known namespace is a namespace that a clerk has discovered and cached as a result of configuration information, datagrams received on a local area network (LAN), or an explicit management command. You can enter commands directed to this entity from either NCL or DNSCP.

DNS Clerk Manual Name Server

A manual name server creates knowledge in the local clerk's cache about a server that exists across a wide area network (WAN). You can enter commands directed to this entity from either NCL or DNSCP.

DNS Clerk Remote Clearinghouse

A remote clearinghouse is a clearinghouse that a clerk has discovered and cached. A clerk can learn about clearinghouses as a result of configuration information, datagrams received on a local area network (LAN), an explicit management command, or during the process of finding a name. To a clerk, all clearinghouses are remote, even if they exist on the same node as the clerk. You can enter commands directed to this entity from either NCL or DNSCP.

DNS Server

A server handles lookup requests from clerks and maintains the contents of the clearinghouse or clearinghouses at its node. You can enter commands directed to this entity from either NCL or DNSCP.

DNS Server Clearinghouse

A clearinghouse is a database containing a collection of directory replicas at a particular server. Commands directed to this entity manage NCL attributes of the clearinghouse and perform NCL management functions such as enabling or disabling the clearinghouse. You can enter these commands from either NCL or DNSCP.

Group

A group lets you assign a uniform set of access rights to several users at once. DECdns does this by mapping a set of names representing the group members to a single name (the group name).

Link

A soft link is a pointer providing an alternate name for an object entry, directory, or other soft link.

Object

An object entry is the name of a resource (such as a node, print queue, or application) that is stored in the namespace.

Replica

A replica is a copy of a directory. Each copy, including the original or master, is referred to as a replica.

Subtree

A subtree is a specific directory and its contents or a hierarchy of directories and their contents.

4.3. Attribute Groups

Every DECdns entity has attributes that contain data associated with that entity. Attributes describe the operational properties of an entity and specify other information that regulates or monitors the entity's behavior. Some attributes have a single value; others contain a set of values. Attributes fall into one of four categories:

Characteristics

Reflect or affect the operational behavior of an entity. Some characteristics are static and cannot be modified; others can be modified with DNSCP or NCL commands.

Counters

Record the number of times a particular event or problem occurred since the entity was last enabled.

Identifiers

Uniquely distinguish an entity from any other entity.

Status Attributes

Reflect the current operational state of an entity.

4.4. Prepositional Phrases

You can use prepositional phrases to affect the destination or content of command output. Generally these phrases are most useful with the `show` and `directory` commands. Chapter 11 documents the appropriate use of prepositional phrases in individual commands.

You can use as many prepositional phrases as you want, being sure to precede each phrase with a comma and a space. The following is an overview of the prepositional phrases:

, with <i>attribute</i> [<i>relop</i>] <i>value</i>	Limits a directive only to those entities whose attributes have certain values. If you do not specify a <i>relop</i> (relational operator), the default is an equal sign. Other valid relational operators are greater than (>), less than (<), greater than or equal to (>=), less than or equal to (<=), and not equal (<>). If you specify multiple <i>with</i> phrases in a command, the target entity must satisfy all of them to be selected. This phrase works only with commands that can operate on multiple items at a time (such as <code>show</code> and <code>directory</code> commands).
, to <i>file=filename</i>	Redirects the output to <i>filename</i> . If the file does not exist, this command creates it. If the file does exist, its contents are overwritten.
, to extend <i>file=filename</i>	Appends the output to an existing <i>filename</i> . If the file does not exist, it is created.
, to <i>terminal</i>	Directs the output to the terminal. This is the default option.

4.5. NCL Access Control Information

Commands that you can enter from either DNSCP or NCL allow you to manage entities on remote systems in the network. You can specify an access control string, which consists of a user name and a password, for an account on the remote system you wish to access. Enter the access control string as part of the node name specification in the format `nodename"user-name password"`. In the following example, `syspasswd` is the password of the system account on node `.nrl`. (In this example, the default namespace specified for the clerk is `IAF`.)

```
ncl> set node .nrl"system syspasswd" dns clerk default namespace IAF
```

The account you use to perform local or remote entity management system must have the `NET$MANAGE` rights identifier. All `show` commands require the `NET$EXAMINE` rights identifier. See Chapter 11 for complete information on the access rights and rights identifiers required for commands you can enter from both DNSCP and NCL.

Note

Because of the way that NCL and OpenVMS interact, remote creation of DECdns clerks and servers is not possible. To use the `create dns clerk` and `create dns server` commands, you must be logged into the clerk or server to which you are directing the command.

4.6. Supplementary Commands

This section describes supplementary DNSCP commands that allow you to perform the following tasks:

- Read commands from files
- Control the confidence level, timeout value, and display format of timestamps and nicknames

- Specify a preferred clearinghouse to examine an attribute's value
- Specify a default entity name

Use the `do` command or run `@filename` from inside DNSCP to read a file of commands.

The following command reads a list of `show status` commands from the file `.status`.

```
dns> do .status
```

You can create a `.dnscpinit` file if you want DECdns to execute a set of commands automatically when you start the control program. The `dnscpinit.` file should reside in the `SYS$LOGIN` directory. Note that the dot (`.`) follows the `dnscpinit` file name.

Confidence Level Commands

These commands set and display the confidence level of clerk calls. Setting the confidence controls the accuracy level and cost of clerk calls. The `set dnscp confidence[=]value` command sets the value as one of the following: `low`, `medium`, or `high`. A low confidence level means the clerk obtains information from caches or the most convenient server. A medium level means the clerk obtains information directly from a server, and a high level obtains information only at master replicas. The initial value is `medium`.

The following command sets the confidence level of clerk calls to `high`:

```
dns> set dnscp confidence high
```

The `show dnscp confidence` command shows the current confidence level of clerk calls:

```
dns> show dnscp confidence
```

Timeout Commands

These commands set and display the length of time, in seconds, that the control program will wait for a clerk call to complete. You can use the `set dnscp timeout[=]value` command to increase the timeout value if you are having trouble with calls not completing. This command sets the value as either a number of seconds or the word `default`, which is 30 seconds for most operations. You can also use the value `0` to indicate the `default` value.

The following command sets the timeout value to 60 seconds:

```
dns> set dnscp timeout 60
```

The `show dnscp timeout` command displays the current timeout value:

```
dns> show dnscp timeout
```

Commands That Display Timestamps and Namespace Nicknames

The timestamp display commands set and display the format of timestamps, which is useful for troubleshooting or if you need to discover the timestamp for a namespace. The `set dnscp timestamp display[=]value` command controls the format in which timestamps are displayed. Specify one of the following units for `value`: `time`, `hexadecimal`, or `default`. The initial setting is the default value `time`, a human-readable date and time.

The following command causes the control program to display timestamps in hexadecimal notation:

```
dns> set dnscp timestamp display hex
```

The `show dnscp timestamp display` command displays the current format of timestamps:

```
dns> show dnscp timestamp display
```

The nickname display commands control the format in which namespace nicknames are displayed in DNSCP. The `set dnscp nickname display[=value]` command sets the value as one of the following units: time, hexadecimal, timestamp, name, or default. The initial setting is the default value name.

The following command sets the nickname to be displayed in the same way as its namespace creation timestamp (NSCTS) is displayed:

```
dns> set dnscp nickname display timestamp
```

The `show dnscp nickname display` command displays the current format of nicknames in the control program:

```
dns> show dnscp nickname display
```

Preferred Clearinghouse Commands

These commands enable you to specify a clearinghouse from which to read attribute values for entries stored in that clearinghouse. You cannot specify a preferred clearinghouse for modifications.

The `set dnscp preferred clearinghouse clearinghouse-name` command enables you to specify the clearinghouse from which to read the values of specific individual attributes using `show clearinghouse` commands of the form:

```
show clearinghouse clearinghouse-name attribute-specifier
```

where the optional *attribute-specifier* is the name of an attribute or attribute group, such as `all characteristics` or `DNS$ACS` (the access control set for the clearinghouse). The following example sets the preferred clearinghouse to `.paris_ch`.

```
dns> set dnscp preferred clearinghouse .paris_ch
```

The `set dnscp preferred clearinghouse` command (or the `set dnscp preferred clearinghouse any` command) causes DNSCP to revert to the default, which is to use any clearinghouse.

The `show dnscp preferred clearinghouse` command displays the current clearinghouse mode:

```
dns> show dnscp preferred clearinghouse
```

Default Entity Commands

These commands set and display a default entity. To set the default entity, enter `set dnscp default entity entity-type entity-name`. When the control program starts, the default entity is the root directory. This command only works for `directory` and `show` commands.

The following command sets the default entity to the directory `.pjl`.

```
dns> set dnscp default entity directory .pjl
```

The `show dnscp default entity` command displays the current default entity.

```
dns> show dnscp default entity
```

Local Root Commands

These commands set and display your local root setting. The local root is a prefix that DECnet-Plus software obtains automatically by stripping off the rightmost simple name of the local node's full name. DECnet Phase V Session Control creates the local root as a reserved name in the DNS \$SYSTEM logical name table. The `set dnscp local root` command enables you to override the systemwide local name setting for your current DNSCP session. To set the local root, enter `set dnscp local root directory-name`.

The following command sets the local root to the `.pjl` directory in the IAF namespace:

```
dns> set dnscp local root IAF:.pjl
```

The `show dnscp local root` command displays the current local root.

```
dns> show dnscp local root
```

4.7. Wildcards

You can use wildcard characters in the last simple name of entity names you specify in `show` and `directory` commands and in some `subtree` entity commands. You can also use wildcards for specifying principals in commands that affect access rights and group membership. Table 4.1 describes the valid wildcard characters you can use.

Table 4.1. Wildcard Characters

Symbol	Meaning
*	Matches zero (0) or more characters in the name you specify in a simple name
?	Matches exactly one character in the name you specify
...	Searches any part of the directory hierarchy at or below this level for a match

See Chapter 11 for more information on using wildcard characters in specific commands.

4.8. Editing the Commands

You can cancel commands, edit command lines, continue a command beyond one line, or recall commands within DNSCP.

Canceling a Command

Press `Ctrl/Y` to cancel command processing during command entry or while the command is being processed.

Continuing a Command Line

To continue a long command line onto the next line, type a space and then a hyphen at the end of the first line:

```
dns> set group .sales.testgroup DNS$GroupRevoke -
```

_> 2019-12-31-12:00:00 090-00:00:00

Recalling a Command

You can recall previously typed commands and avoid the inconvenience of retyping long commands. The recall buffer holds up to 20 previously entered commands. Once a command is displayed, you can reexecute or edit it.

To display the commands stored in the recall buffer, press Ctrl/B or the up arrow and down arrow keys.

Press Ctrl/B once to display your previous command. Press Ctrl/B again to display your next previous command, and so on, to the last saved command.

Press the up arrow and down arrow keys to display the previous and successive commands, respectively. Press the arrow keys repeatedly to move backward or forward through the buffer of saved commands until you display the command you want to reuse or edit.

Chapter 5. Managing DECdns Access Control

DECdns allows you to control access to the clearinghouses, directories, object entries, and soft links in your namespace. The access rights to a name that you grant users determine how they can use the name and what management operations they are allowed to perform on it. For object entries that represent physical network resources, such as DECdfs access points, VSI Notes files, disks, and print queues, remember that DECdns access control protects only the names that represent these resources in the namespace, not the resources themselves.

You control access to `dns server`, `dns clerk`, `dns clerk known namespace`, `dns clerk manual nameserver`, and `dns clerk remote clearinghouse` entities with operating system rights identifiers. These are Network Control Language (NCL) entities, and because they are not actually contained in a namespace, DECdns access control cannot protect them. See the *VSI DECnet-Plus for OpenVMS Network Management Guide* to control access to these entities.

This chapter presents management information on the following topics:

- How DECdns access control works (Section 5.1)
- Adding, modifying, and denying access (Section 5.2)
- Setting up access control in a new namespace (Section 5.3)
- Displaying access rights (Section 5.4)
- Removing access (Section 5.5)
- Managing groups (Section 5.6)
- Modifying principals and removing access for a subtree (Section 5.7)

5.1. How DECdns Access Control Works

The access rights that you grant users to a name are stored as separate sets of values within the access control set (ACS) associated with the name's `DNS$ACS` attribute. Within a name's ACS is a list of access control entries (ACEs). Each ACE consists of two parts: a principal, describing the user (or users) to whom the access is granted, and a rights list containing the specific access rights granted to the principal. The ACEs stored in a name's ACS collectively determine who (which user or application accounts) can access the name.

5.1.1. Specifying a DECdns Version 2 Principal

The principal of an ACE can be the name of an individual user, a name with one or more wildcard characters to denote several users (see Section 4.7), or a group name. You specify a DECdns Version 2 (DECnet Phase V style) principal with a `nodename.username` combination, where `nodename` is the DECdns full name of the node. Separate the node name and user name with a dot (.). For example, to specify a user named `jones`, whose login account is on node `.titan`, enter `.titan.jones`.

You represent an application program as a principal with the node name and account name under which the application is running. For example, you specify an application running on node `.eng.orion` under an account named `program1` as `.eng.orion.program1`.

Specify the `DNS$Server` principal for the server running on node `.polaris` as `.polaris.dns$server`.

5.1.2. Specifying a DNS Version 1 Principal

If your namespace uses servers running both DECdns Version 2 and Version 1 of the VAX Distributed Name Service (DNS), you will sometimes need to create ACEs that specify principals in the Version 1 format. You specify a Version 1 principal with a `nodename::username` combination, where `nodename` is the six-character-maximum DECnet Phase IV-style node name. Separate the node name and user name with two colons (`:`) rather than with a dot as in a Version 2 principal.

For example, to specify a Version 1 principal for a user named `jones`, whose login account is on node `titan`, enter `titan::jones`. (See Section 5.4 for an example display of access rights that include Version 1 principals.)

If any of your Version 2 DECdns directories store replicas on DNS Version 1 servers, make sure you always create two sets of ACEs when granting access to those directories and their contents. One set must specify Version 2 principals, and the other set must specify Version 1 principals.

For example, suppose you replicated the Version 2 directory `.eng` in both Version 2 and Version 1 servers. To grant user `jones` on node `titan` access to the `.eng` directory, and to ensure that `JONES` receives the same access to the directory in every clearinghouse where a replica is stored, you must create two ACEs. One ACE must specify the Version 2-style principal `.titan.jones`. The other ACE must specify the Version 1-style principal `titan::jones`.

Note

The DNS Version 1 and DECdns Version 2 principal expressions for granting world access, `*:*` and `*.*` respectively, permit access to any user on any node, but *only* within the particular namespace in which the access control entries (ACEs) containing these expressions were created. Because you do not have to enter a namespace nickname as part of a principal expression, and DNS Version 1 does not display the namespace nickname associated with the principal expression of ACEs, it is easy to assume *incorrectly* that the expressions can be used for granting world access to any user, on any node, in any namespace.

5.1.3. Specifying Group Principals

You can also specify a DECdns group as the principal of an ACE. A group is an object containing a list of members that you can treat as a single unit for various purposes, including access control. A group member can be an individual principal, a wildcard principal, or another group. See Section 5.6 for more information on groups.

5.1.4. DECdns Access Rights and Their Meanings

The five DECdns access rights are read, write, delete, test, and control. Each access right has a slightly different meaning, depending on the kind of name with which it is associated. The access rights are defined as follows:

- Read access allows a principal to look up a name and view the attribute values associated with it.
- Write access allows a principal to create new names and change any modifiable attribute of a name (except its ACS).
- Delete access allows a principal to delete a name from the namespace.

- Test access allows a principal to test whether an attribute of a name has a particular value without actually seeing any of the values (that is, without having read access to the name).

The main benefit of test access is that it gives application programmers a more efficient way to verify an attribute value. Rather than reading the entire set of values, an application can test for the presence of a particular value. DECdns itself uses this function to test for group membership during access checking. You should grant at least test access to all users of client applications that use the test function on their own objects.

- Control access allows a principal to perform any operation on a name, including modifying its ACS. Control access also grants other rights normally reserved only for the creator account or your namespace administrator group, such as the ability to replicate a directory or relocate a clearinghouse. In a secure namespace, you should grant control access judiciously.

Table 5.1 lists the DECdns access rights and describes the operations they enable a principal to perform.

Table 5.1. Summary of DECdns Access Rights

Access Right	Permitted Operation
Clearinghouse	
Read	Look up the clearinghouse by name. Read any attribute of the clearinghouse.
Write	Change the replica type of any replica stored in the clearinghouse. Create or delete replicas in the clearinghouse. Modify any modifiable attribute of the clearinghouse (except its ACS).
Delete	Delete the clearinghouse.
Test	Check for the presence of a specific value in any attribute of the clearinghouse.
Control	Modify the ACS of the clearinghouse. Relocate the clearinghouse on another server.
Directory	
Read	Look up the directory by name. List the names of any child directories of the directory. Read any directory attribute.
Write	Create object entries or soft links in the directory. Skulk the directory. Create, modify, or delete child directories (delete access to the child directories is also required). Dump the directory. Re-create object entries and soft links in the directory. Re-create an existing directory as a child of the directory.
Delete	Delete the directory.

Access Right	Permitted Operation
	Delete any name in the directory.
Test	Check for the presence of a specific value in any attribute of the directory.
Control	Perform any operation on any object entry, soft link, or child pointer in the directory. Read or modify any attribute of the directory (including its ACS). Modify the replica type of a replica or the epoch value of the directory. Merge the directory.
Object Entry and Soft Link	
Read	Look up the object entry or soft link by name. Read any attribute. Perform a wildcard lookup.
Write	Modify any attribute except the ACS. Remove a value from an attribute of an application-defined object entry.
Delete	Delete the name or any attribute associated with it.
Test	Check for the presence of a specific value in any attribute.
Control	Modify the ACS.

You can abbreviate each of the rights you specify in an ACE to its first character (read=r, write=w, delete=d, test=t, control=c). These abbreviations are used in all the example commands that appear throughout this manual.

5.1.5. How DECdns Checks Access

When a principal makes a request to view or manage a name, DECdns searches the name's ACS for an ACE that grants the required access rights. DECdns conducts its search of an ACS in the following order:

1. DECdns first looks for an ACE whose principal matches exactly with the name of the requesting principal, ignoring all ACEs that contain wildcard principals. DECdns stops searching at the first ACE that it finds containing a matching principal. If that ACE contains the required access rights, the principal's requested operation is carried out; if not, DECdns returns an error message.
2. If DECdns cannot find an exact matching principal, it next examines any ACEs containing wildcard principals for a match. If DECdns finds an ACE containing a matching wildcard principal that does not include the required access rights, it ignores it. (This differs from the behavior described in step 1, where DECdns stops searching at the first ACE it finds that contains a matching principal.)
3. If DECdns cannot find an ACE containing a wildcard principal that grants the required access rights, it searches the ACS for any ACEs referring to groups of which the requesting principal is a member.
4. If no match can be found among the wildcard principals or groups, DECdns denies the requested access and returns an error message.

Because DECdns stops searching as soon as it finds the first exact match of an individual principal name, you can create special null ACEs for individual users that grant no access rights to the users, and deny access that might otherwise be granted to them through wildcard principals or group membership. See Section 5.2.4 for information on how to create null ACEs to deny access to individual users.

5.2. Adding, Modifying, and Denying Access

By default, DECdns grants all five access rights (read, write, delete, test, and control) to the creator account of any new clearinghouse, directory, object entry, or soft link. As you expand and manage your namespace, you can modify this default scheme by adding, modifying, or removing access rights for particular names.

Note

When adding, modifying, or denying access to a name that exists in a namespace other than your clerk's default namespace, you must specify the nickname of the nondefault namespace as part of the name.

5.2.1. Adding Access

Use the `add access` command to create an ACE and add it to the ACS of the name you specify.

Examples

The following command grants read, write, and test access to user `smith` on node `.orion` for an object entry named `.admin.disk3`.

```
dns> add object .admin.disk3 access .orion.smith for r,w,t
```

The following command grants read access to all users that have accounts on node `.vega` to an object entry named `.sales.quota_disk`.

```
dns> add object .sales.quota_disk access .vega.* for r
```

The following command grants all users of a namespace read and test access to an object entry named `.mfg.public_disk`.

```
dns> add object .mfg.public_disk access ... for r,t
```

The following command grants read, write, test, and control access to the local `.Paris2_CH` clearinghouse on behalf of an access control group named `.testgroup`.

```
dns> add clearinghouse .paris2_ch access .testgroup for r,w,t,c
```

5.2.2. Modifying Existing Access

You can also use the `add access` command to overwrite the list of rights granted to a principal by an existing ACE.

Example

The following `show object access` command displays an ACE that grants read, write, and test access to user `smith` on node `.orion` to a node object entry named `.admin.mynode`.

```
dns> show object .admin.mynode access
      SHOW
      OBJECT   IAF:.admin.mynode
      AT      31-MAY-2019:09:26:00
DNS$ACS (set) = :
      Flags = propagate
      Rights = read, write, test
(V) Principal = .orion.smith
```

The following `add object access` command overwrites this ACE and replaces it with a new ACE that grants `.orion.smith` only read and test access to `.admin.mynode`.

```
dns> add object .admin.mynode access .orion.smith for r,t
```

The following `show object access` command displays the result of the preceding command:

```
dns> show object .admin.mynode access
      SHOW
      OBJECT   IAF:.admin.mynode
      AT      31-MAY-2019:09:28:00
DNS$ACS (set) = :
      Flags = propagate
      Rights = read, test
(V) Principal = .orion.smith
```

5.2.3. Making Access Assignment Easier

Two features of DECdns access control make it easier for you to assign access to directories and their future contents: automatic rights propagation and default ACEs.

5.2.3.1. Using Automatic Rights Propagation

When you create an ACE for a directory, DECdns automatically copies (propagates) the ACE into the ACSs of all the child directories you may later create under that directory.

Example

The following command creates an ACE that grants read and test access to user `jones` on node `.rigel` for the directory `.sales`.

```
dns> add directory .sales access .rigel.jones for r,t
```

The following `show directory access` command displays the ACE created with the preceding command:

```
dns> show directory .sales access
      SHOW
      DIRECTORY IAF:.sales
      AT      11-JAN-2019:05:13:00
DNS$ACS (set) = :
      Flags = propagate
      Rights = read, test
(V) Principal = .rigel.jones
```

The `Flags = propagate` line indicates that, by default, DECdns will copy this ACE into the ACS of any child directory later created under the `.sales` directory. This means that, by creating a single ACE granting user `Jones` read and test access to `.sales`, you also automatically grant user

Jones the same rights to any child directory that may subsequently be created under the `.sales` directory. Remember that an ACE you create for a directory is inherited only by the child directories that you create after you create the ACE; directory ACEs are not propagated to child directories that already exist.

5.2.3.2. Suppressing Automatic ACE Propagation

Automatic propagation of every ACE that you create for a directory always occurs unless you include the `nopropagate` option in the `add access` command that you enter to create the ACE.

You should use the `nopropagate` option when you want to create an ACE for a directory, but would prefer that the rights you grant be applied only to that particular directory and not be inherited by any future child directories.

Example

The following command creates an ACE that grants read, write, and test access to all users on node `.rigel` for the `.mfg` directory. By including the `nopropagate` option, you prevent this access from propagating to any child directories that may later be created under the `.mfg` directory.

```
dns> add directory .mfg nopropagate access .rigel.* for r,w,t
```

The following `show access` command displays the ACE created with the preceding command:

```
dns> show directory .mfg access
      SHOW
  DIRECTORY  IAF: .mfg
           AT  25-AUG-2019:06:31:00
  DNS$ACS (set) = :
           Flags = nopropagate
           Rights = read, write, test
  (V) Principal = .rigel.*
```

5.2.3.3. Creating Default ACEs

You can use the `add access` command's `default` option to create a default ACE for a directory that applies specifically to the directory's future contents (soft links, application-defined object entries, groups, and clearinghouse object entries). Although a default ACE is associated with a directory name, it applies only to the future contents of the directory, not to the directory itself.

Note

Because a clearinghouse itself is not contained in a directory, it cannot inherit ACEs. Only the clearinghouse object entry (which represents a clearinghouse) is actually contained in a directory and is, therefore, able to inherit ACEs automatically. To grant access to a clearinghouse itself, use the `add clearinghouse access` command to explicitly create appropriate ACEs in the ACS of the clearinghouse for the users and applications that require it.

Remember that default ACEs apply only to names that are created in the directory after you create the ACEs; they do not affect access to names that already exist in the directory.

As with other directory ACEs, the access you grant with a default ACE also propagates to the future contents of any child directories of the associated directory unless you suppress the propagation by including the `nopropagate` option in the command that you use to create the default ACE. See Section 5.2.3.2 for information on how to use the `nopropagate` option.

Examples

The following command creates a default ACE that grants read and test access to user `jones` on node `.rigel` for the future contents of the `.dist` directory and the future contents of its child directories:

```
dns> add directory .dist default access .rigel.jones for r,t
```

The following `show directory access` command displays the ACE created with the preceding command:

```
dns> show directory .dist access
      SHOW
  DIRECTORY  IAF:.dist
          AT  31-APR-2019:10:47:06
DNS$ACS (set) = :
      Flags = propagate, default
      Rights = read, test
(V) Principal = .rigel.jones
```

The following command creates a default ACE that grants read, write, and test access to all users on node `.orion` for the future contents of the `.admin` directory. Because the `nopropagate` option is also used in the command, these rights will not apply to the future contents of any child directories later created under the `.admin` directory.

```
dns> add directory .admin default,nopropagate access .orion.* -
_> for r,w,t
```

The following command displays the ACE created with the preceding command:

```
dns> show directory .admin access
      SHOW
  DIRECTORY  IAF:.admin
          AT  21-DEC-2019:16:24:21
DNS$ACS (set) = :
      Flags = nopropagate, default
      Rights = read, write, test
(V) Principal = .orion.*
```

5.2.4. Using Null ACEs to Deny Access

Because of the sequence in which DECdns searches a name's ACS for a security match, you can deny a user access to a name by creating a null ACE for the name that specifies a user's individual login name as principal, but contains no rights in the rights list. You can also create null ACEs that specify as principal the account under which a client application is running. You express the absence of access rights in an ACE by entering the word `none` in the rights list portion of the ACE.

Example

The following command creates a null ACE that denies user `jones` on node `.vega` access to an object entry named `.eng.rnd_notes`.

```
dns> add object .eng.rnd_notes access .vega.jones for none
```

Note

Null ACEs are only valid for explicit principals. They are not valid for implicit or explicit groups. For example, the following command creates an invalid ACE entry – a null ACE to deny access to all

node `.vega` users whose principal names begin with the character string `abc` (that is, access to an object entry named `.eng.rnd_notes`).

```
dns> add object .eng.rnd_notes access .vega.abc* for none
```

Null ACEs that you create for a directory will propagate to all future child directories and, by combining these ACEs with default null ACEs to deny access to future directory contents, you can lock a user out of the namespace from that directory level downward through the hierarchy. By creating such ACEs for the root directory in a new namespace, you can deny a user account access to an entire namespace.

The following two commands deny user `.orion.smith` all access to the `.eng` directory. These examples assume that the `.eng` directory has just been created, contains no object entries or soft links, and has no child directories.

1. The following command creates an ACE that denies `.orion.smith` access to the `.eng` directory. Because the `nopropagate` option is not used in the command, this ACE will be inherited by all child directories that may later be created under the `.eng` directory.

```
dns> add directory .eng access .orion.smith for none
```

2. The following command creates a default ACE that denies access to all names that may be created later in the `.eng` directory. Again, because the `nopropagate` option is omitted from the command, this ACE will also be inherited by the contents of any child directories later created under `.eng`.

```
dns> add directory .eng default access .orion.smith for none
```

For more information on how DECdns checks access, see Section 5.1.5.

5.3. Setting Up Access Control in a New Namespace

If you intend to create a large namespace that will contain multiple directories at many levels, VSI recommends that you first plan a consistent access control policy and be ready to implement the policy after you configure your first DECdns server. At that time, and before you create and populate your directory hierarchy, you should take the following steps:

1. Add members to the `.DNS_Admin` administrator group that was created for you automatically during the configuration of the first server in your new namespace. Then, grant full access (read, write, delete, test, and control) on behalf of the group to the entire namespace beginning at the root directory.
2. Implement a namespacewide access control policy, beginning at the root directory, to grant the general user population a minimum set of rights that will propagate to lower-level directories and their contents as they are created.

5.3.1. Adding Members to Your Namespace Administrator Group

To make the task of managing and troubleshooting your namespace easier, the DECnet-Plus configuration process on the first DECdns server in your namespace automatically creates an access control group in the root directory named `.DNS_Admin`. Before the group can be of any use,

you must add, as members, the persons in your organization who are responsible for managing, administering, and troubleshooting your namespace. Because this group can possess unlimited access to the entire namespace, its members can intervene, whenever necessary, to restore lost access or solve other problems that might arise. See Section 5.6.2 for complete information on how to add members to your namespace administrator group and other access control groups that you create.

5.3.2. Adding Access for Your Namespace Administrator Group

After you add members to your administrator group, you can create ACEs that grant the group full access to the following names:

- **Root directory (.)** — You can assign full access to the root directory on behalf of the administrator group that will be inherited by all future names created in the root directory. This access will also propagate to all future child directories and their future contents.
- **Initial clearinghouse** — Unlike clearinghouse object entries, clearinghouses themselves (including your namespace's initial clearinghouse) are not actually contained within a directory, and therefore cannot inherit access. To grant the administrator group full access to the initial clearinghouse itself, you must use the `add clearinghouse access` command to explicitly create appropriate ACEs in the ACS of the clearinghouse.

Because clearinghouses cannot inherit access, you should institute a policy requiring that your administrator group always be granted full access to all new clearinghouses as they are created. Most new clearinghouses in your namespace will be created as a result of server configuration.

To Add Full Access

Enter the following `add directory access` commands to grant your `.DNS_Admin` administrator group full access to the namespace's root directory, the root directory's initial clearinghouse, and to every directory, object entry, and soft link that may later be created in the namespace:

1. The following `add directory access` command grants the group `.DNS_Admin` full access to the root directory. This access will be inherited by all directories later created under the root.

```
dns> add directory . access .DNS_Admin as group for r,w,d,t,c
```

2. The following `add directory access` command, using the `default` option, grants `.DNS_Admin` full access to all names that may later be created in the root directory. This access will also be inherited by the future contents of all directories that are later created under the root.

```
dns> add directory . default access .DNS_Admin as group for r,w,d,t,c
```

3. The final command grants `.DNS_Admin` full access to the initial clearinghouse `.init_CH`.

```
dns> add clearinghouse .init_ch access .DNS_Admin as group -
_> for r,w,d,t,c
```

Creating Directory-Level Administrator Groups

To delegate local authority, you can create additional directory-level access control groups for each of the functional directories in your namespace (`.Sales_Admin`, `.Eng_Admin`, and so on). Each local administrator group could have full access to the contents of the directory for which

it is responsible and include as members all the names of the current managers of that directory. With groups as the main method of granting access control, the namespacewide administrator group (`.DNS_Admin`) could simply add and remove members of a local group instead of creating and deleting individual ACEs every time there is a change in management responsibility for a directory.

5.3.3. Implementing a General Access Control Policy

Immediately after you add members to your administrator group and grant the group full access, VSI recommends you implement a policy to control user access to the new namespace and its future contents. The access control policies described in Section 5.3.3.1 to Section 5.3.3.4 are:

- Full Access
- Read, Write, and Test
- Read and Test
- Explicit Access

The first three policies (Full Access; Read, Write, and Test; and Read and Test) establish a basic set of access rights for all potential users of your namespace and allow you to take advantage of automatic rights propagation. When implemented at the root level in a new namespace, these policies automate the creation of most of the ACEs that you would otherwise need to create individually. Although none of these policies eliminates the need for some future access modifications, implementing the policy that most closely provides the minimum level of security you require can help minimize the task of assigning access to future directories and the names later created within them.

The fourth policy (Explicit Access) does not grant general users a specific set of access rights to the namespace, and therefore does not take advantage of automatic rights propagation.

5.3.3.1. Full Access Policy

The Full Access policy grants all potential users read, write, delete, test, and control access to all names (except clearinghouses). This policy permits all users (people and client applications) to perform any operation on any directory, object entry, group, or soft link in your namespace.

Although the Full Access policy is the easiest to manage and minimizes the number of ACEs that you must explicitly create, it is also the least secure because it allows all users to create new names, modify attributes of names, delete names, relocate clearinghouses, and merge directories. You might implement this policy in small or experimental, single-site namespaces where maintaining strict security is not an issue, or where other measures already minimize the risk of unauthorized access to the namespace.

To implement the Full Access policy, beginning at the root directory in a new namespace, enter the following two `add directory access` commands:

```
dns> add directory . access ... for r,w,d,t,c
dns> add directory . default access ... for r,w,d,t,c
```

The first command creates an ACE that grants full access to all principals for the root directory. These rights will be inherited by all child directories later created under the root.

The second command, specifying the `default` option, creates an ACE that grants all principals full access to the future contents of the root directory. These rights automatically propagate to the contents of all child directories that are later created under the root.

5.3.3.2. Read, Write, and Test Policy

The Read, Write, and Test policy grants all potential users read, write, and test access to the contents of the namespace. Because this policy does not include delete and control access, users are prevented from deleting names, relocating clearinghouses, modifying replica sets, and modifying a name's ACS. Because the policy grants write access to all users, it is most appropriate for a namespace in which the majority of users frequently need to create and populate their own directories.

To implement the Read, Write, and Test policy, enter the same two commands used to implement the Full Access policy (Section 5.3.3.1), but include only read, write, and test access in the rights list of each ACE for (r, w, t).

5.3.3.3. Read and Test Policy

The Read and Test policy grants all potential users read and test access to the contents of the namespace, but requires you to explicitly assign write access every time a user or application needs to create a name, modify an attribute of a name, create or delete a replica, modify replica types, or skulk a directory. The Read and Test policy is most appropriate for a namespace in which the majority of users only need to look up names or enumerate attributes, and where the tasks of creating names and modifying their attributes are reserved for namespace administrators, server managers, or other management personnel. In such a namespace, read and test rights provide users with all the access they normally require during the day-to-day use of their DECdns client applications.

If you implement this policy, you should consider granting write access for client application accounts to the particular directories in which they need to create their own object entries. This will save you the trouble of modifying the access to those directories every time an application needs to create, modify, or delete its own object entries.

To implement the Read and Test policy, enter the same two commands used to implement the Full Access policy (Section 5.3.3.1), but include only read and test access in the rights list of each ACE for (r, t).

Note

Although the preceding three access control policies are described beginning at the root directory of the namespace, you can also implement them for any directory, at any level, and on behalf of any principal or access control group. For example, to maintain greater security on your namespace's root directory and its contents, you could implement the Read and Test policy at root level. Then, starting at directories one level below the root, implement the Read, Write, and Test policy. As with a root-level implementation, the best time to implement a policy for a lower-level directory is immediately after the directory is created.

5.3.3.4. Explicit Access Policy

The Explicit Access policy differs from the preceding three policies because it does not grant a basic set of rights to users, and therefore does not initially provide the convenience of automatic rights propagation. You do not propagate ACEs from the root directory to implement this policy.

The Explicit Access policy provides the greatest namespace security, but can also require extensive access control management. By using wildcards and groups to express multiple principals, and by taking advantage of automatic propagation of lower-level directory ACEs, you can minimize the number of ACEs you will need to explicitly create for each name.

5.4. Displaying Access Rights

You use the `show access` commands to display the ACEs associated with the clearinghouse, directory, object entry, or soft link that you specify.

Example 1

The following command displays the ACEs stored in the ACS of the `.eng` directory in the IAF namespace:

```
dns> show directory .eng access

      SHOW
  DIRECTORY  IAF:.eng
      AT 26-NOV-2019:18:36:03
DNS$ACS (set) = :
      Flags = propagate, group
      Rights = read, write, delete, test, control
      Group = .DNS_Admin
DNS$ACS (set) = :
      Flags = propagate, default
      Rights = read, test
(V) Principal = .orion.smith
DNS$ACS (set) = :
      Flags = propagate, default
      Rights = read, test
(V) Principal = .rigel.jones
```

Note

You can also display access by using the `show` command and specifying the `DNS$ACS` attribute of the name whose ACS you want to examine. See Chapter 8 for more information and examples of how to display namespace information.

Example 2

The following example shows the access control set for directory `.budget`, which contains both DECdns Version 2 (DECnet Phase V) and DNS Version 1 (DECnet Phase IV) principals.

```
dns> show directory .budget access

      SHOW
  DIRECTORY  IAF:.budget
      AT 17-APR-2019:14:54:54
DNS$ACS (set) = :
      Flags = none
      Rights = read, write, delete, test, control

(IV) Principal = ABC::SYSTEM
(V) Principal = IAF:.ABC.SYSTEM
DNS$ACS (set) = :
      Flags = none
      Rights = read, write, delete, test, control

(IV) Principal = ORION::DNS$SERVER
(V) Principal = IAF:.ORION.DNS$SERVER
```

```
DNS$ACS (set) = :
  Flags = authenticated
  Rights = read, write, delete, test, control

(V) Principal = IAF:.budget.orion_ch
DNS$ACS (set) = :
  Flags = default, propagate, group
  Rights = read, write, delete, test, control

  Group = IAF:.ad_users
```

5.5. Removing Access

Use the `remove access` commands to remove an ACE from the ACS of the name that you specify. This command removes ACEs from a name's ACS one at a time. You cannot remove individual access rights (read, write, delete, test, or control) separately.

To remove a directory ACE created with the `default` option (default ACE), you must include the `default` option in the `remove access` command.

Note

The DECdns software does not prevent you from deleting all the ACEs associated with a name. When you remove ACEs, make sure that, by doing so, you do not remove all the access that exists to the name you specify. If you accidentally delete all the access to a name, see Chapter 12 for instructions on how to restore access.

Examples

The following `show object access` command displays an existing ACE that grants user `smith` (on node `.orion`) read and test access to an object entry named `.sales.work_disk2`.

```
dns> show object .sales.work_disk2 access
      SHOW
      OBJECT  IAF:.sales.work_disk2
      AT     26-JAN-2019:09:16:51
DNS$ACS (set) = :
  Flags = none
  Rights = read, test
(V) Principal = .orion.smith
```

To remove access rights of user `Smith` to `.sales.work_disk2`, enter the following `remove object access` command:

```
dns> remove object .sales.work_disk2 access .orion.smith
```

The following `show directory access` command displays an existing ACE that grants user `jones` (on node `.polaris`) full access to the `.sales` directory. Another ACE, created with the `default` option, grants `Jones` full access to the future contents of the `.sales` directory.

```
dns> show directory .sales access
      SHOW
      DIRECTORY  IAF:.sales
      AT     02-FEB-2019:21:09:31
DNS$ACS (set) = :
```

```
Flags = propagate
Rights = read, write, delete, test, control
(V) Principal = .polaris.jones
DNS$ACS (set) = :
Flags = default
Rights = read, write, delete, test, control
(V) Principal = .polaris.jones
```

The following `remove directory access` command removes access rights of user Jones to the `.sales` directory itself:

```
dns> remove directory .sales access .polaris.jones
```

The following `remove directory access` command removes access rights of user Jones to the future contents of the `.sales` directory:

```
dns> remove directory .sales access as default .polaris.jones
```

The access rights of user Jones to the `.sales` directory and its future contents have now been removed. Remember, however, that the preceding two commands do not remove any access rights that Jones might have been granted to names that already exist in the `.sales` directory. To remove access rights of user Jones to these names, you must issue separate `remove access` commands for each name, or use the `remove subtree access` command to remove access for the entire directory and its contents.

The following `show directory access` command displays an existing ACE, created with the `nopropagate` option, that grants read and test access to the `.mfg` directory for user smith on node `.vega`.

```
dns> show directory .mfg access
      SHOW
      DIRECTORY IAF: .mfg
      AT 21-MAR-2019:08:16:50
      DNS$ACS (set) = :
      Flags = nopropagate
      Rights = read, test
      (V) Principal = .vega.smith
```

The following `remove directory access` command removes this ACE. Note that you do not have to include the `nopropagate` option in the command.

```
dns> remove directory .mfg access .vega.smith
```

Remember that removing an ACE associated with an individual user does not revoke the rights granted to the user by any ACEs containing wildcard principals that include the user or access control groups of which the user is a member. To revoke the access rights of individual members of an access control group, remove the user from the group. See Section 5.6.4 for information on how to remove group members.

5.6. Managing Groups

A group is an object entry that contains a collection of principals (members) stored in the group's `DNS$Members` attribute. Whenever you identify users to whom you want to grant a common set of access rights, you can treat the users as a unit by creating an access control group of which they all are members. When you add a member to an access control group, the principal described by that member acquires all the access rights assigned to the group. When you remove a member from an

access control group, the principal described by that member loses all the access granted to the group. By assembling principals into access control groups, you can simplify the task of assigning access to multiple users.

Using access control groups can also improve performance by helping you avoid the creation of ACSs that contain large numbers of ACEs specifying individual principals. Maintaining large ACSs degrades response time during access checking and can consume significant amounts of memory and disk space. Access control groups make it possible for you to keep the number of ACEs you require to a minimum.

The DECnet-Plus configuration program on the first DECdns server in your namespace automatically creates an access control group named `.DNS_Admin` to which you can add, as members, namespace administrators, server managers, and other personnel to whom you want to grant unlimited access to the entire namespace. See Section 5.6.2 for information on how to add group members. See Section 5.3.2 for information on assigning access for a namespace administrator group in a new namespace.

5.6.1. Creating a Group

Use the `create group` command to create a group with the name you specify. To create a group, you need write access to the directory in which you intend to create the group.

You can use the `set group` command to cause requesting clerks to cache the results of the test operations that they direct to the group. Although this may optimize the test operations of requesting clerks, only a slight increase in overall performance is realized. See Chapter 11 for more information on the `set group` command.

Example

The following `create group` command creates a group named `.group1` in the `.sales` directory:

```
dns> create group .sales.group1
```

5.6.2. Adding Group Members

Immediately after creation, a group does not contain any members. The principal that creates a group is not included as a member. Before a group can be of any use, you must add members.

To add members to a group, you must have write access to the group. The account under which a group is created will already have this access. Do not store more than 100 members in a group. VSI recommends that no group contain more than 75 members.

A simple way to limit the number of members in any group is to create subgroups that are members of the original group. For example, an administrator wants to create a group with 200 members who all have authorization to manage a certain directory in the namespace. The group will be called `.dir_admin`. Two possible solutions are:

- Create three groups called `.dir_admin_a_to_f`, `.dir_admin_g_to_l`, and `.dir_admin_m_to_z`. These three groups are entered as the only three members of the group `.dir_admin`. Each contains a part of the alphabetically sorted list of members.
- Create subgroups that use some other partitioning algorithm, such as by site code or group function instead of the alphabet as used in the preceding solution.

To Add Group Members

Use the `add member` command and specify the member (principal) you want to add to the group. You can specify an individual principal, a wildcard principal, or another group as a group member.

Note

When adding another group as a member, be careful not to accidentally create a group loop by adding a group of which another group is itself a member. In such a case, DECdns is unable to verify access and generates an error message. See Chapter 12 for information on how to detect and eliminate loops.

Examples

The following `add group member` command adds user `smith` on node `.orion` to the namespace administrator group `.DNS_Admin`.

```
dns> add group .DNS_Admin member .orion.smith
```

The following `add group member` command adds all users on all nodes named in the `.mfg` directory to a group named `.mfg.camgroup`.

```
dns> add group .mfg.camgroup member .mfg.*...
```

The following `add group member` command adds a group named `.dist.transport_group` as a member to the existing group `.mfg.camgroup`.

```
dns> add group .mfg.camgroup member .dist.transport_group
```

Modifying a Group's ACS

Although the account under which a group is created automatically receives full access to the group, membership in a group conveys no access rights to the group itself. To protect the identity of group members, you may want to grant only test access to the group for most of the group's members. This prevents individual members from determining who the other members of the group are. Be certain, however, to grant at least one member full access to the group; this allows that member to add and remove other members, or to delete the group if necessary.

5.6.3. Modifying Group Membership

You can use the `change subtree group member` command to replace an existing group member with a new group member in all access control groups named in the directory or subtree that you specify. (A subtree can be a single directory and its contents, or a directory and all its child directories and their contents.) By appending the recursion notation `(. . .)` to the directory that you specify, you can extend the command's effect to the groups contained in all child directories of that directory. If you use the command recursively, you can use the `exclude` argument to exclude all groups contained within particular child directories from group member modification.

This command provides a convenient way for you to modify a group member specification in multiple groups with a single command. For example, user `smith`, whose login account is on node `.orion`, is represented as a member in several access control groups as `.orion.smith`. If Smith's login account is moved to node `.trifid` (or if node `.orion` is renamed `.trifid`), the old member specification `.orion.smith` is no longer valid and will not grant Smith the access that membership in these groups was intended to convey. To maintain Smith's access, you can use the `change`

`subtree group member` command to substitute the old member `.orion.smith` for the new member `.trifid.smith` in all appropriate groups.

To use the `change subtree group member` command, you must have write access to the group whose member you intend to modify. If you use the command recursively, you must have write access to all groups affected by the command.

Examples

The following `change subtree group member` command replaces the old member `.orion.smith` with the new member `.trifid.smith` in all groups named in the `.sales` directory. Note that, for the new member, you only need to specify the portion you want to change (the node name `.trifid`) in the command.

```
dns> change subtree .sales group member .orion.smith .trifid
```

The following `change subtree group member` command replaces the old member `.vega.group1` with the new member `.vega.group2` in all groups named in the `.admin` directory and all its child directories. Note that, because you are changing the entire group member, you must specify both the node name and user name (`.vega.group2`) as the new member.

```
dns> change subtree .admin... group member .vega.group1 .vega.group2
```

The following `change subtree group member` command replaces the old member `iaf:.orion.smith` with the new member `abc:.orion.smith` in all groups named in the `abc:` namespace. Note that you only need to specify the namespace nickname portion of the new member (`abc:`) in the command.

```
dns> change subtree ... group member iaf:.orion.smith abc:.
```

5.6.4. Removing Group Members

Use the `remove member` command to remove a group member from the group or groups that you specify. You must have write access to the group from which you intend to remove members.

Remember that removing a principal from membership in a group only denies that principal the access rights granted to that group. Loss of membership in a group does not revoke the access rights that may otherwise be granted to the group member as an individual principal, a wildcard principal, or by membership in other groups.

Examples

The following `remove member` command removes user `jones` on node `.orion` from the namespace administrator group `.DNS_Admin`.

```
dns> remove group .DNS_Admin member .orion.jones
```

The following `remove member` command removes all users on all nodes named in the `.mfg` directory from the group named `.mfg.camgroup`.

```
dns> remove group .mfg.camgroup member .mfg.*...
```

The following command removes the group named `.dist.transgroup` from membership in the group named `.mfg.camgroup`.

```
dns> remove group .mfg.camgroup member .dist.transgroup
```

5.6.5. Removing Group Members from Multiple Groups

You can use the `remove subtree group member` command to remove a group member from all the groups named in the directory or subtree that you specify. When you remove a group member from a group, the user specified by that member automatically loses all access rights granted to that group.

By appending the recursion notation (`. . .`) to the directory that you specify, you can extend the command's effect to all groups named in that directory and to all the child directories of that directory. If you use the command recursively, you can use the `exclude` argument to exclude the groups in specific child directories from group member removal.

To use the `remove subtree group member` command, you must have write access to the group (or groups) named in the directory or subtree that you specify. If you use the command recursively, you must have write access to all groups affected by the command.

Remember that removing a principal from membership in a group only denies that principal the access granted to the group. Loss of membership in a group does not revoke the access rights that may otherwise be granted to a group member as an individual principal, a wildcard principal, or by membership in other groups.

Examples

The following `remove subtree group member` command removes user `.orion.jones` from membership in all groups named in the `.sales` directory:

```
dns> remove subtree .sales group member .orion.jones
```

The following `remove subtree group member` command removes user `.vega.smith` from membership in all groups named in the `.eng` directory and all its child directories:

```
dns> remove subtree .eng... group member .vega.smith
```

The following `remove subtree group member` command removes the group named `.transport_group` from membership in all the groups in the namespace:

```
dns> remove subtree ... group member .transport_group
```

5.6.6. Deleting a Group

You may want to delete a group when the circumstances that warranted the group's creation no longer exist. For example, you should delete a group if the user group for whom the group was created disbands, or if the directories to which the group was collectively granted access are deleted.

To delete a group, you must have delete access to the group. Make sure that, by deleting a group, you are not removing the only access that exists to a particular name.

To Delete a Group

Use the `delete group` command to delete a group from the namespace. You do not need to remove a group's members before you delete the group.

Example

The following `delete group` command deletes an access control group named `.testgroup` from the `.eng` directory:

```
dns> delete group .eng.testgroup
```

After You Delete a Group

After you delete a group, the ACSs of the names to which the group was assigned access will still contain ACEs that contain the deleted group as a principal. To avoid confusion, you should remove the ACEs that refer to the deleted group from the ACSs of those names. You can use the `remove subtree access` command to remove multiple ACEs with a single command. See Section 5.7.2 for more information on the `remove subtree access` command.

5.7. Modifying Principals and Removing Access for a Subtree

DECdns provides several commands that allow you to modify existing principals in ACEs or to remove ACEs associated with a particular directory and all of its contents or with an entire subtree of directories. Section 5.7.1 and Section 5.7.2 describe how to use these commands to make the task of modifying or removing multiple ACEs more convenient.

5.7.1. Modifying Principals

You can use the `change subtree access` command to replace an existing principal with a new principal in all the ACEs associated with the directory (and contents) that you specify. Use the command's optional `exclude` argument to exclude from principal modification the ACEs associated with the object entries or soft links in the specified directory.

You can also use the `change subtree access` command recursively. By appending the recursion notation (`. . .`) to the directory that you specify, you can also modify the ACEs associated with all the child directories (and contents) of the specified directory. If you use the command recursively, you can use the `exclude` argument to exclude from principal modification the ACEs associated with specific child directories.

For example, a user named `smith`, whose login account is on node `.orion`, is expressed as principal `.orion.smith` in the ACEs associated with names throughout the namespace. If Smith's login account is moved to node `.trifid` (or if node `.orion` is renamed `.trifid`), the old principal specification `.orion.smith` no longer grants Smith the proper access.

Rather than individually removing each of these old ACEs and replacing them with new ACEs that specify `.trifid.smith`, you can use one `change subtree access` command to update the old principal expression in all affected ACEs.

To use the `change subtree access` command, you must have the following access rights:

- Control and write access to the directory that you specify.
- Control and write access to the contents of the directory.
- If you use the command recursively, you also need control and write access to all child directories (and contents) of the directory that you specify.

Examples

The following `change subtree access` command replaces the old principal `.orion.smith` with the new principal `.trifid.smith` in all ACEs associated with the `.sales` directory and all

its contents. Note that, for the new principal, you only need to specify the portion you want to change (the node name `.trifid`) in the command.

```
dns> change subtree .sales access .orion.smith .trifid
```

The following `change subtree access` command replaces the old principal `.oberon.jones` with the new principal `.oberon.smith` in all ACEs associated with the `.mfg` directory, its contents, and all child directories and their contents with the exception of ACEs associated with soft links. Note that, since you are changing the entire principal, you must specify both the node name and user name (`.oberon.smith`) as the new principal.

```
dns> change subtree .mfg... access .oberon.jones .oberon.smith -
_> exclude links
```

You can also use the `change subtree access` command to maintain the usability of ACEs associated with names that were merged from one namespace into another. For example, user `smith`, in the `iaf:` namespace, is expressed as principal `iaf:.orion.smith` in ACEs throughout the `iaf:` namespace. Suppose that, because of corporate restructuring, the `iaf:` namespace is merged into the `abc:` namespace. To maintain the access that Smith needs in the new namespace, you can enter the following `change subtree access` command to substitute the new namespace nickname `abc:` for the old namespace nickname `iaf:` in the principal expression of every ACE that specifies `iaf:.orion.smith` throughout the `abc:` namespace:

```
dns> change subtree ... access iaf:.orion.smith abc:
```

The following `change subtree access` command substitutes the new namespace nickname `abc:` for the old namespace nickname `iaf:` in the principal expression of every ACE in the `abc:` namespace:

```
dns> change subtree ... access iaf:. abc:.
```

5.7.2. Removing Access from Multiple Names

You can use the `remove subtree access` command to remove all ACEs containing the principal that you specify from the ACSs associated with a particular directory (and its contents). Use the command's optional `exclude` argument to exclude from removal the ACEs associated with all object entries and soft links in the specified directory.

By appending the recursion notation (`. . .`) to the directory that you specify, you can also remove the ACEs associated with all the child directories (and contents) of the specified directory. If you use the command recursively, you can use the `exclude` argument to exclude from removal the ACEs associated with specific child directories.

For example, if a user leaves your namespace, you can use the `remove subtree access` command to remove all ACEs that specify the user as a principal. Similarly, if a particular access control group is deleted, you can remove all ACEs that specify the group's name as a principal.

To use the `remove subtree access` command, you need the following access rights:

- Control and write access to the directory that you specify.
- Control and write access to the contents of the directory.
- Control and write access to all child directories (and contents) of the directory that you specify, if you use the command recursively.

Examples

The following `remove subtree access` command removes all ACEs that contain `.vega.jones` as a principal from the ACS of the `.eng` directory and from the ACSs of its contents:

```
dns> remove subtree .eng access .vega.jones
```

The following `remove subtree access` command removes all ACEs that specify an access control group named `.test_group` as a principal from the ACS of the `.sales` directory, its contents, and from the ACSs of all its child directories and their contents:

```
dns> remove subtree .sales... access .test_group
```

The following `remove subtree access` command removes all ACEs that specify `.vega.jones` as a principal from the ACS of the `.eng` directory and all its child directories. ACEs associated with the object entries and soft links in these directories are not removed.

```
dns> remove subtree .eng... access .vega.jones exclude -  
_> objects, exclude links
```

Chapter 6. Managing Clerks, Servers, and Clearinghouses

All DECdns clerks are initially created and enabled as part of the DECnet configuration process. The first server and clearinghouse in a namespace are created and enabled as part of the configuration process (`NET$CONFIGURE ADVANCED`).

All additional servers and their resident clearinghouses are created and enabled with the DECdns configuration program. See Chapter 10 for complete information on how to use the DECdns configuration program.

The clerk, server, and clearinghouse entities are largely self-regulating and, apart from your routine monitoring of their status and counter attributes, should require only minor management intervention. You can manage these entities remotely by specifying the node name of their host systems in your commands.

This chapter describes how to monitor the following clerk, server, and clearinghouse information:

- Status (Section 6.1)
- Counters (Section 6.2)
- Clerk communication with specific clearinghouses (Section 6.3)
- Contents of a clearinghouse (Section 6.4)

This chapter also describes the following additional management tasks that you may need to perform:

- Modifying a clerk's timeout interval (Section 6.5)
- Modifying a clerk to use the cluster alias (Section 6.6)
- Deleting and restarting clerks and servers (Section 6.7)
- Preserving a clearinghouse across a server system upgrade (Section 6.9)
- Backing up namespace information (Section 6.10)

For information on how to delete a clearinghouse, see Section 9.6.

6.1. Monitoring Status

At any time, a clerk, server, or clearinghouse can be in only one of the following states: `off`, `initial`, `on`, `shut`, or `broken`. The clerk, server, and clearinghouse entities are available only when they are enabled (in the `on` state). See the reference pages for the `show dns clerk`, `show dns server`, and `show dns server clearinghouse` commands in Chapter 11 for full descriptions of the states for these entities.

To Display Clerk Status

Use the `show dns clerk` command and specify the `state` attribute to check the current status of a clerk.

To use the `show dns clerk` command, you must have the `NET$EXAMINE` rights identifier.

Example

The following command displays the status of the local clerk:

```
dns> show dns clerk state
```

To Display Server Status

Use the `show dns server` command and specify the `state` attribute to check the current status of a server.

To use the `show dns server` command, you must have the `NET$EXAMINE` rights identifier.

Example

The following command displays the status of the local server:

```
dns> show dns server state
```

To Display Clearinghouse Status

Use the `show dns server clearinghouse` command and specify the `state` attribute to check the current status of a clearinghouse.

To use the `show dns server clearinghouse` command, you must have the `NET$EXAMINE` rights identifier.

Example

The following command displays the status of the clearinghouse running on the local server:

```
dns> show dns server clearinghouse state
```

6.2. Monitoring Counters

Every clerk, server, and clearinghouse maintains a set of counters to keep track of the read, write, and other operations that it has performed (or that were performed on it) since it was last enabled. You can monitor these counters to determine the type and volume of the `DECdns` traffic being generated on your network. Clerk, server, and clearinghouse counters are fully described in Chapter 11.

Some clerk, server, and clearinghouse counters are incremented by `DECdns` events. See Appendix D for more information on these events.

To Display Clerk Counters

Use the `show dns clerk` command with the `all counters` attribute specifier to display the current counter values of a clerk.

To use the `show dns clerk` command, you must have the `NET$EXAMINE` rights identifier.

Example

The following command displays the current values of all counters associated with the clerk running on remote node `.umbriel`.

```
dns> show node .umbriel dns clerk all counters
```

To Display Server Counters

Use the `show dns server` command with the `all counters` attribute specifier to display the current counter values of a server.

To use the `show dns server` command, you must have the `NET$EXAMINE` rights identifier.

Example

The following command displays the current values of all counters associated with the local server:

```
dns> show dns server all counters
```

To Display Clearinghouse Counters

Use the `show dns server clearinghouse` command with the `all counters` attribute specifier to display the current counter values of a clearinghouse.

To use the `show dns server clearinghouse` command, you must have the `NET$EXAMINE` rights identifier.

Example

The following command displays the current value of all counters associated with the clearinghouse `.parisl_ch` running on node `.vega`.

```
dns> show node .vega dns server clearinghouse .parisl_ch all -  
-> counters
```

6.3. Monitoring Clerk Communication with Specific Clearinghouses

Every clerk maintains a separate set of remote clearinghouse counters to keep track of read, write, and other operations that it directs to each of the clearinghouses with which it communicates. These records collectively represent the `dns clerk remote clearinghouse` entity for a particular clerk.

Note

The term *remote* in `dns clerk remote clearinghouse` applies to all clearinghouses. From a clerk's perspective, all clearinghouses are remote, including any clearinghouse that resides on its own system. See Chapter 4 for information on the `dns clerk remote clearinghouse` entity.

You can monitor a clerk's remote clearinghouse counters to look at the distribution of the clerk's transactions to each of the clearinghouses that it uses and to find out where a clerk's requests are most often directed.

To Monitor a Clerk's Communication with Specific Clearinghouses

Use the `show dns clerk remote clearinghouse` command with the `all counters` attribute specifier to display the current counter values for any or all of the clearinghouses with which a clerk has communicated.

To use the `show dns clerk remote clearinghouse` command, you must have the `NET $EXAMINE` rights identifier.

Examples

The following command displays the `dns clerk remote clearinghouse` counters maintained by the local clerk for the `.ny1_ch` clearinghouse:

```
dns> show dns clerk remote clearinghouse .ny1_ch all counters
```

The following command displays the `dns clerk remote clearinghouse` counter values for all the clearinghouses used by the local clerk:

```
dns> show dns clerk remote clearinghouse * all counters
```

6.4. Monitoring the Contents of a Clearinghouse

You can display the names and replica types of all the directories stored in a clearinghouse. This information can help you perform the following tasks:

- Monitor the number of replicas in a directory's replica set.
- Modify the replica set of any directory stored in the clearinghouse.
- Gather the name and replica-type information that you need to create a duplicate clearinghouse on another server.

To Monitor the Contents of a Clearinghouse

Use the `show clearinghouse` command and specify the `DNS$CHDirectories` attribute to display the creation timestamps (CTSs) and names of all the directories stored in a clearinghouse.

To use the `show clearinghouse` command, you must have read permission to the clearinghouse.

Examples

The following command displays the value of the `DNS$CHDirectories` attribute for the local clearinghouse `.Paris1_CH`:

```
dns> show clearinghouse .paris1_ch dns$chdirectories
```

6.5. Modifying a Clerk's Timeout Interval

The value assigned to a clerk's `clerk timeout` attribute specifies how long the clerk waits for a response to a request. After a clerk issues a request, it waits for the specified length of time and, if no response is received from `DECdns` within that time period, returns a timeout error message to the requesting application.

A clerk's `clerk timeout` attribute is set to a value of 150 seconds when the clerk is created. If you experience a large number of timeout errors on a clerk, you should either increase the clerk's timeout interval or replicate the information the clerk most often requests in a clearinghouse that is located closer on the network to the clerk system.

For example, a clerk that frequently initiates skulks of a directory whose replicas are spread over extreme distances throughout the network may often time out before receiving a response from the clearinghouses in which these remote replicas are stored. To make it possible for the clerk's skulks of this directory to succeed, you should increase the clerk's `clerk timeout` attribute value to a duration long enough to ensure that the clerk will not time out before receiving a response from the remote locations.

To Modify a Clerk's Clerk Timeout Attribute

Use the `set dns clerk` command to specify a new value for the `clerk timeout` attribute. If you do not specify a value in the command, the attribute is set to its default value of 150 seconds.

To use the `set dns clerk` command, you must have the `NET$MANAGE` rights identifier.

Example

The following command sets the `clerk timeout` attribute to a value of 180 seconds for the local clerk:

```
dns> set dns clerk clerk timeout 180
```

6.6. Modifying a Clerk To Use the Cluster Alias on Server Requests

DECdns clerk requests from nodes in an OpenVMS Cluster can send the cluster alias address as the source address. The default behavior is to send the individual node address.

To use this functionality, edit the `SYS$MANAGER:DNS$CLERK_CLUSTER.NCL` file and set `outgoing alias = true`.

To affect the running system, use the following NCL command on all nodes in your cluster:

```
NCL>set session control application dnsclerk outgoing alias = true
```

Note

Implementing this functionality might require nontrivial changes to the current access control in your namespace because you are changing the source address of the DECdns clerk requests.

6.7. Deleting and Restarting Clerks and Servers

You may want to delete the clerk or server running on a particular system when the active clerk or server processes need to be stopped, such as to perform diagnostic or troubleshooting work on the system.

When you delete a clerk, only the active clerk processes are deleted. Deleting a clerk does not remove the clerk software from the system or delete the clerk's cache. If you delete the clerk from a system that also functions as a DECdns server, that server and the clearinghouse it serves become unavailable.

When you delete a server, only the active server processes are deleted. Deleting a server does not remove the server software or the server's clearinghouse database from the system. Furthermore, deleting a server from a system does not affect the system's ability to function as a DECdns clerk.

Note

Each system on which DECdns runs uses Network Control Language (NCL) startup and shutdown scripts that you can edit and run as part of the DECnet startup or shutdown procedure. These scripts are the recommended method of deleting and restarting clerks and servers. For more information, see the *VSI DECnet-Plus for OpenVMS Network Management Guide*.

If you intend to delete only the server, leaving the clerk running, use the procedure described in Section 6.7.2.

6.7.1. Deleting a Clerk

To delete a clerk, use the instructions provided in the subsections that follow.

Before You Delete a Clerk

Before you can delete a clerk, you first must disable it (turn it off) by entering the `disable dns clerk` command.

To use the `disable dns clerk` command, you must have the NET\$MANAGE rights identifier.

On systems running a DECdns server, be sure you disable the server before disabling the clerk. If you do not disable the server and clerk in the right sequence, the server will not operate properly when you restart it. When you disable the clerk, it writes the contents of its cache to disk. Unless you explicitly delete the cached information, or change its file location, the information remains available and is automatically read back into the clerk's cache when the clerk processes are next started up.

Example

The following command disables the local clerk:

```
dns> disable dns clerk
```

To Delete a Clerk

Use the `delete dns clerk` command to delete the clerk.

To use this command, you must have the NET\$MANAGE rights identifier.

Examples

The following commands are required in the sequence shown to delete a clerk running on a local node that is also running DECdns server software:

```
dns> disable dns server
dns> disable dns clerk
dns> delete dns clerk
```

The following commands disable and delete the clerk running on node `.miranda`, which is a clerk-only system.

```
dns> disable node .miranda dns clerk
dns> delete node .miranda dns clerk
```

To Delete a Clerk Cache

To write the DECdns clerk in-memory cache to disk, you must stop DECnet. Simply deleting the DECdns clerk software does not remove the in-memory copy of the cache. After stopping DECnet, you can then delete the cache files, rename them, or change their file location. Then, reboot the system.

The cache files (DNS\$CACHE.*) are in SYS\$SYSROOT:[SYSEXE].

Example

The following commands shut down the DECnet software, delete the two clerk cache files, and restart DECnet:

```
$ @sys$manager:net.$shutdown
$ delete sys$sysroot:[sysex]dns$cache.0000011411;1
$ delete sys$sysroot:[sysex]dns$cache.version;11413
! Reboot the system!!!!
```

6.7.2. Deleting a Server

Before You Delete a Server

Before you can delete a server, you first must disable it (turn it off) by entering the `disable dns server` command.

To use the `disable dns server` command, you must have the NET\$MANAGE rights identifier.

Note

When you issue the `disable dns server` command, DECdns writes to disk a new clearinghouse checkpoint file that contains all the updates received since the last time the checkpoint file was written to disk. This can take up to 30 minutes to complete, depending on disk speed, memory, and the size of the checkpoint file. By waiting for this write operation to complete, you decrease the time required for the next server startup.

Example

The following command disables the server on node `.vega`.

```
dns> disable node .vega dns server
```

To Delete a Server

Use the `delete dns server` command to delete the server from the system that you specify.

To use the `delete dns server` command, you must have the NET\$MANAGE rights identifier.

Example

The following command deletes the server from node `.vega`.

```
dns> delete node .vega dns server
```

Deleting Server Files Left Behind

When you delete a server, files used by the server are left behind. These files contain pointers to the existing namespace, for example. If you want to reconfigure a deleted server to have a new namespace, you must delete files that the deleted server had been using. Otherwise, the new server will attempt to use files that point to the old server's default namespace. To delete these files and prepare for reconfiguring a new server, take the following steps:

1. Stop and delete the DECdns server (see previous subheadings).
2. Delete the clearinghouse files and other files that point to the default namespace.
3. Stop the DECdns clerk and delete the DECdns clerk cache file and any other clerk-related files that might have pointers to the default namespace (see Section 6.7.1).
4. Create a new `NET$DNS_CLERK_STARTUP.NCL` file without any `Known Namespace` parameter.
5. Reboot the system. This is necessary because although the DECdns clerk is stopped, its cache remains mapped in memory. The reboot clears this cache.
6. To create the new namespace for the reconfigured server, take the following steps:
 - a. Use the `SYS$MANAGER:NET$CONFIGURE.COM` procedure and, if DECnet-Plus has already been configured on the new server system, select option 2 ("Change Naming Information"). If DECnet-Plus has not been configured, do the full configuration rather than option 2.
 - b. The configuration procedure asks if you want to disable the DECdns server by renaming the DECdns server startup procedure `NET$DNS_SERVER_STARTUP.COM` to `NET$DNS_SERVER_STARTUP.COM-DISABLED`. Answer Yes.
 - c. The configuration procedure asks for a list of directory services to use on the system. You must specify `LOCAL` only (Local namespace) this time—do not specify any other name services.
 - d. When prompted for the system's node name, specify a Local namespace name.
 - e. After the configuration procedure completes, rerun the configuration procedure and select option 2.
 - f. This time, when you are prompted for the name services to use, you must specify DECdns as the first name service. VSI recommends listing DECdns only for now. Then, once the new namespace is created successfully for the server, you can rerun the configuration procedure to add other name services.
 - g. When the procedure asks for a node full name, you must enter a full name that includes the new namespace name (not one that already exists in the network). The `NET$CONFIGURE` program must determine and report that it did not find the specified namespace being served on the LAN (or else you would create an Ambiguous Nickname problem on the DECdns clerks on your LAN). The configuration procedure provides a list of currently available namespaces from which to choose. You must reject this list by selecting option 0.
 - h. The procedure then asks if you wish to create a new namespace. Answer yes to this question to proceed with creating a new DECdns Version 2 namespace. See Section 10.6 for more information on how to create a new namespace.

Appendix G includes two sample command files that perform the steps outlined above.

6.7.3. Restarting a Deleted Clerk

To restart a clerk, enter the following command from the system prompt:

```
$ @sys$startup:dns$clerk_startup
```

To restart a server, enter the following command from the system prompt:

```
$ @sys$startup:dns$server_startup
```

Note that you must have the NET\$MANAGE rights identifier to run these commands and that the commands must be entered on the system where the clerk or server resides.

Depending on the disk speed, memory, and the size and state of the clearinghouse database (in particular, the checkpoint file), the `enable dns server` command, which is called in the `SYS $STARTUP:DNS$SERVER_STARTUP` command procedure, can take several minutes. If the server did not complete the checkpoint operation the last time it was shut down (for example, the system crashed during the shutdown process), server startup can take up to 30 minutes.

6.8. Controlling the LAN Devices Used By DECdns

The static device tables formerly used to determine the devices used by DECdns have been removed. Now, DECdns uses the \$DEVSCAN and \$GETDVI system services to build a list of devices that have the following characteristics:

- a device class of DC\$SCOM (synchronous communication device)
- a device characteristic of DEV\$V_NET
- a device status of UCB\$V_ONLINE and UCB\$V_TEMPLATE
- a device name in the form `_ddcn:`

You can use the logical name `DNS$ETHERNET_DEVICE` to provide a list of devices that DECdns should NOT use. All devices must be in the form `_ddcn:`, where `dd` is the OpenVMS physical device name, `c` is the controller letter, and `n` is the port number. The string is limited to 255 characters and can contain spaces and other text which is ignored by DNS. For example, the following two commands tell DECdns not to use the `_EIA0:` and `_FWA0:` devices.

```
$ DEFINE/SYSTEM DNS$ETHERNET_DEVICE "Don't use _EIA0: and _FWA0: "  
$ DEFINE/SYSTEM DNS$ETHERNET_DEVICE "_EIA0:_FWA0:"
```

Note

Unterminated network adapters can cause the dynamic device recognition process to hang. Either terminate all network adapters or include any unterminated devices in the `DNS$ETHERNET_DEVICE` logical definition.

6.9. Preserving a Clearinghouse Across a Server System Upgrade

If you plan to upgrade the operating system software on a DECdns server system, and you want to preserve the clearinghouse (or clearinghouses) resident on the system, follow this procedure:

1. Before you perform a server system upgrade, invoke the DECdns Control Program and enter the following command to disable the server:

```
dns> disable dns server
```

2. Exit the DECdns Control Program and return to the system prompt. Then, back up the following DECdns files:

- `SYS$SYSDEVICE:[DNS$SERVER]clearinghouse-name.CHECKPOINTnnnnnnnnnn`
- `SYS$SYSDEVICE:[DNS$SERVER]clearinghouse-name.TLOGnnnnnnnnnn`
- `SYS$SYSDEVICE:[DNS$SERVER]clearinghouse-name.version`
- `SYS$MANAGER:DNS_FILES.TXT`
- `SYS$MANAGER:NET$DNS_SERVER_STARTUP.NCL`

3. Perform the system upgrade.
4. Restore all DECdns files you backed up in step 2.
5. Run the `SYS$MANAGER:NET$STARTUP` procedure. It starts the clerk and then automatically discovers the restored files and starts the server which, in turn, enables the clearinghouse. See the *VSI DECnet-Plus for OpenVMS Network Management Guide* for complete information on how to run `@SYS$MANAGER:NET$STARTUP`.

6.10. Backing Up Namespace Information

Because updates and skulks of directories can occur asynchronously, and because of the distributed nature of a namespace itself, you cannot always depend on traditional backup methods to preserve DECdns data. The following sections describe the proper use of the following three backup mechanisms:

- **Directory replication** — For most namespaces, replication is the only completely reliable method of protecting namespace data. By maintaining multiple replicas of each directory, you can easily restore lost or damaged clearinghouse database files. (See Section 6.10.1.)
- **DECdns dump/merge facilities** — You can merge recently dumped directory information back into your namespace hierarchy to restore deleted directories and their contents. (See Section 6.10.2.)
- **Operating system backups** — VSI does not recommend that you use traditional operating system backups unless your entire namespace resides on a single clearinghouse. (See Section 6.10.3.)

6.10.1. Using Replication to Back Up Namespace Information

Directory replication is always the most reliable way to back up the information in your namespace. When you create a new replica of a directory at a clearinghouse, you are not only distributing the

information but also creating an up-to-date, real-time backup of the information. If a replica in one clearinghouse becomes unavailable, users can look up the information they need in another replica of the directory in some other clearinghouse. The more replicas of a directory you create, the more likely users will always be able to find the information contained in the directory somewhere in the namespace.

If an entire clearinghouse is corrupted, you can restore it by creating a new clearinghouse and then creating new replicas of the directories that were stored there. See Chapter 12 for complete information on how to restore a lost clearinghouse.

6.10.2. Using the Dump/Merge Facilities to Back Up Directories and Their Contents

You can use the `dump subtree` command to produce an interim file that contains a copy of the structure and contents of any portion of your directory hierarchy. You can then use this file as a backup to restore deleted directories and their contents by loading the file back into your namespace with the `merge file` command.

If you have an interim file available that contains a recent copy of a deleted directory, you can use the `merge file` command to append that copy of the directory back under its former parent directory. Then, using the `create replica` command, you can create a new replica of the directory in each of the clearinghouses from which the directory was deleted. Although the information in an interim file may be slightly out of date, using an interim file to restore the directory and its contents is usually more efficient than creating a new directory and repopulating it one name at a time. See Section 9.4 for information on how to create an interim file.

Note

If you try to restore only a subset of your directory hierarchy by using an interim file that contains the entire namespace, be aware that, although the operation will restore the lost information, many conflicting names will be displayed on your screen and sent to the failures file (if you specify a file). You can ignore these conflict reports on the screen. If you specified a failures file, you can delete it after the restoration.

Remember that the `dump subtree` command deals exclusively with directories and their contents. It does not copy clearinghouses or their associated clearinghouse object entries to the interim file and therefore cannot be used to restore clearinghouses or to account for discrepancies in information among individual replicas resident on different clearinghouses. Furthermore, as with traditional operating system backups, the directory information in an interim file only reflects what the directory (or directory subtree) contained at the time you created the file.

See Chapter 9 for information on using the `dump subtree` and `merge file` commands.

6.10.3. Using Operating System Backups

Because a namespace is a distributed database to which modifications are synchronized at variable intervals, any traditional backup of a particular server system will always contain old and incomplete information. If you frequently create, modify, or delete names, restoring an out-of-date backup may cause recently created names to disappear, recent modifications to be reversed, or recently deleted names to reappear in the namespace. The degree to which a traditional backup reflects the current condition of a clearinghouse depends entirely on how recently the backup was created and what modifications were made since that time.

If you decide to use operating system backups, you should only back up the server systems whose clearinghouses store master replicas of directories. Make sure you disable the clearinghouses on these systems before you perform the backups.

If your namespace is small enough to be maintained on one clearinghouse, you can reliably use traditional operating system backups to save and restore the clearinghouse data. If only one clearinghouse exists, only one replica (the master replica) of each directory exists. This eliminates the need to account for the discrepancies that may exist among multiple directory replicas. Remember that the more frequently you back up clearinghouse data, the more up to date that information will be if you need to restore it.

Chapter 7. Managing Directories

If you manage a namespace with 50 or fewer DECdns servers, you can name all your clearinghouses and create all your object entries in the root directory and may not need to create additional directories. However, if you manage a namespace with more than 50 DECdns servers, you should consider creating at least one additional level of directories under the root.

This chapter contains management information on the following directory topics:

- Creating a directory (Section 7.1)
- Creating a replica (Section 7.2)
- Deleting a replica (Section 7.3)
- Skulking a directory (Section 7.4)
- Adjusting a directory's convergence (Section 7.5)

For information on how to delete a directory, see Section 9.3.

7.1. Creating a Directory

By creating directories, you make it possible to replicate and manage groups of object entries according to where, how often, or by whom they are used. Grouping application-defined object entries into separate directories also makes it possible to collectively control access to the entries and allows you to take advantage of automatic rights propagation. See Chapter 5 for complete information on how to grant access to directories and their contents.

You create directories for the following purposes:

- To establish an initial directory hierarchy for your namespace.
- To add directories to the upper levels of the hierarchy.
- To create additional lower-level directories to store object entries that are created locally and used by namespace user groups and applications. Below a certain level in your hierarchy, you may prefer to allow users to create and manage their own directories.

Creating a directory hierarchy requires planning. Make sure you read the naming and hierarchy design information in the *VSI DECnet-Plus Planning Guide* before you create directories.

To Create a Directory

To create a directory, you need the following access rights:

- Write access to the parent of the new directory
- Write access to the clearinghouse in which you are naming the new directory

Use the `create directory` command to create a new directory (master replica) with the name that you specify. When you use this command, DECdns, by default, stores the master replica of the new directory in the same clearinghouse that stores the master replica of the new directory's parent directory.

Note

For the `create directory` command to execute successfully, the clearinghouse that stores the master replica of the new directory's parent directory must be available when you enter the command.

Creating a Directory in a Nondefault Clearinghouse

Sometimes DECdns may not be able to create the new directory in the default clearinghouse. If this happens, or if you want to create the directory in a clearinghouse other than the default clearinghouse, use the `create directory` command's optional `clearinghouse` argument to specify another clearinghouse. The clearinghouse you choose must be named in either the root directory or in a directory that is closer to the root than the directory you are creating. (The DECdns software enforces this requirement to guarantee compliance with clearinghouse rule 2. See Appendix B for more information on the clearinghouse rules.)

Examples

The following command creates a directory named `.sales`. DECdns, by default, stores the master replica of this new directory in the clearinghouse containing the master replica of the root directory.

```
dns> create directory .sales
```

The following command creates a new directory named `.region1` under its parent directory `.sales`. The `clearinghouse` argument directs DECdns to store the master replica of the new directory in a clearinghouse named `.eng.london1_CH` rather than in the clearinghouse that stores the master replica of the `.sales` directory.

```
dns> create directory .sales.region1 clearinghouse .eng.london1_ch
```

After You Create a Directory

After you create a directory, enter the `show directory access` command to display the DNS \$ACS attribute of the new directory. Make sure that the users and applications for whom the directory was created have the proper access. If the required access was not inherited from the access control set (ACS) of the new directory's parent directory, use the `add directory access` command to create the necessary access control entries (ACEs). See Chapter 5 for complete information on how to add access to a directory.

7.2. Creating a Replica

When you create a directory, it becomes the master replica. You can create read-only replicas of a directory for the following purposes:

- To distribute the information contained in the directory throughout your network, and to make it more accessible to users and applications at other locations.
- To improve response time, especially in a namespace dispersed over a large geographic area. You should create replicas in clearinghouses that are located near the user groups and applications that most frequently use the information contained in the directory.
- To preserve a backup of the information contained in the master replica of the directory. Maintaining multiple replicas ensures that the temporary loss of an individual replica will not cause an interruption in service and that permanent loss of a replica can be easily recovered. Even

directories that store information used at only one particular site should be replicated in at least one other clearinghouse (preferably on a server at another location) so a local failure at one site will not cause both replicas to be unreachable at the same time.

All replicas that you create with the `create replica` command are read-only replicas. In a read-only replica, users and client applications can look up information, but are not permitted to create new information or modify existing information. You should create replicas in clearinghouses whose users need to access the directory but do not need (or are not permitted) to update its contents. You can modify a directory's replica set to redesignate the master replica or to exclude certain replicas, as explained in Section 9.2.

You can display the replica set for a directory by using the DECdns Control Program command `show directory directory-name dns$replicas` (see Chapter 11).

Before You Create a Replica

Before you create a replica, perform the following steps:

1. Use the `add directory access` command to grant read, write, delete, and control access to the directory for the `DNS$Server` principal on the server node (clearinghouse) where you intend to create the replica. The `DNS$Server` principal requires this access to successfully carry out updates and skulks of the directory. Specify this principal as `nodename.dns$server` in the principal argument of the command.

For example, before creating a replica of the `.eng` directory in the `.NY1_CH` clearinghouse (running on remote server `.taurus`), you would enter the following command:

```
dns> add directory .eng access .taurus.dns$server for r,w,d,c
```

Note

If a replica of the directory is stored on a VAX Distributed Name Service (DNS) Version 1 server (on a DECnet Phase IV node), make sure that both Version 1 and Version 2 (DECnet Phase V) style ACEs exist on the directory and all of the directory's contents before you try to create the replica. Otherwise, the replication fails. See Section 5.1.1 and Section 5.1.2 for information on how to specify Version 2 and Version 1 principals in ACEs.

2. Initiate a skulk of the directory to make sure the new access you added in step 1 is applied to all existing replicas in the directory's replica set. (See Section 7.4 for information on how to skulk a directory.)
3. Make sure all clearinghouses that already store a replica of the directory you intend to replicate are running and available. If any replica in the directory's existing replica set cannot be reached, the replication fails.

For example, if you intend to create a replica of the root directory, then all clearinghouses that currently store a replica of the root directory must be running (in the on state) and available when you try to create the new replica.

To verify that these conditions are satisfied, take the following steps:

- a. For the directory you intend to replicate, use the `show directory` command and specify the `DNS$Replicas` attribute to display the name of every clearinghouse that currently stores a replica of the directory.

- b. With this information, use the `show dns server clearinghouse` command and specify the `state` attribute to make sure each of the clearinghouses is running and available.
4. If a directory contains node object entries, locate at least one replica (preferably the master) on the same LAN as the nodes described by the node object entries. Locate the master replica of each `.DNA_BackTranslation` area directory in the area it is named after, if that area contains DECnet Phase V nodes. In addition, replicate an area directory in other areas most likely to communicate frequently with the nodes whose addresses are contained by the directory.
5. In a solely WAN environment, try to replicate every directory so each can be reached reliably by any DECnet system that needs it.

To Create a Replica

To create a replica, you need the following access rights:

- Control access to the directory you want to replicate
- Write access to that directory's parent directory
- Write access to the clearinghouse where you want to store the replica

Use the `create replica` command to create a read-only replica of a directory and store it in the clearinghouse that you specify.

Example

The following command creates a replica of the `.mfg` directory and stores the replica in a root-level clearinghouse named `.parisl_ch`.

```
dns> create replica .mfg at clearinghouse .parisl_ch
```

7.3. Deleting a Replica

Sometimes, you may need to delete a replica when the information it contains is no longer needed by the local users of the clearinghouse in which the replica is stored. You may also need to delete a replica to prepare for deleting the directory of which the replica is a member or before deleting the clearinghouse in which the replica is stored.

To Delete a Replica

To delete a replica, you must have the following access rights:

- Control access to the directory whose replica you want to delete
- Write access to the clearinghouse from which you are deleting the replica
- Write and delete access to the directory's parent directory

Use the `delete replica` command to delete a replica from the clearinghouse that you specify.

Example

The following command deletes a replica of the `.eng` directory from the `.chicago2_ch` clearinghouse:

```
dns> delete replica .eng at clearinghouse .chicago2_ch
```

Note

You can only delete a directory's master replica by using the `delete directory` or `delete subtree` commands. See Chapter 9 for complete information on how to use these commands to delete a master replica.

7.4. Skulking a Directory

DECdns skulks every directory at regular intervals according to the value assigned to the directory's `DNS$Convergence` attribute. To ensure that updates are distributed to all replicas as soon as possible, you can initiate a skulk of a directory yourself by using the `set directory to skulk` command, rather than waiting for the next scheduled skulk to distribute the new information. You should use this command for the following tasks:

- Distribute crucial updates made to a directory's contents (such as modifications to a name's ACS or a directory's replica set, or the removal or addition of a member in a DECdns group) when you do not want to wait for the next skulk.
- Skulk directories that store replicas on servers that were disabled for an extended period and were just brought back on line.

To Skulk a Directory

To skulk a directory, you must have write access to the directory.

Use the `set directory to skulk` command to initiate an immediate skulk on the directory that you specify. After you enter the command, the DECdns Control Program temporarily suspends the `dns>` prompt while the skulk is in progress. (It may take some time for DECdns to complete skulks of directories with large replica sets.) If the prompt returns with no error messages, the skulk was successful (see Note). If errors are returned before the prompt reappears, the skulk failed. Skulk failure also generates the DECdns Skulk Failed event at the server that stores the master replica of the directory being skulked. See Appendix D for more information on this event.

Note

Under certain circumstances, it is possible to receive the `dns>` prompt before a skulk completes. To be absolutely positive that a skulk operation succeeded, you should check the `DNS$SkulkStatus` attribute at the master replica for the directory (using the `show replica` command).

For a skulk to succeed, every replica in the directory's replica set must be reachable. Skulks may sometimes fail, especially on directories with large replica sets, or when the servers that store replicas of the directory are located over great distances where network connectivity is not always reliable. Skulk failure does not make DECdns unusable. Although the skulking process is unable to update information in a replica that it cannot contact, it always updates information in the replicas it can reach. Temporarily, some replicas contain the latest information and some do not. When a skulk fails, DECdns automatically repeats the skulking process (at an interval based on the directory's convergence value) until all replicas in the set are updated with the latest changes. When all replicas contain identical information, DECdns considers the skulk to have succeeded, and updates the `DNS$AllUpTo` attribute of the directory.

If skulks of a particular directory continue to fail, you can determine the cause by reviewing the DECnet event log of the server that stores the master replica of the directory.

Example

The following command initiates a skulk on the `.admin` directory:

```
dns> set directory .admin to skulk
```

7.5. Adjusting a Directory's Convergence

The value assigned to a directory's `DNS$Convergence` attribute determines how frequently the server that stores the master replica of the directory initiates a skulk of the directory's replica set. A directory's convergence can be set to a value of low, medium, or high.

A directory set to low convergence is skulked at least once every 24 hours. The server on which a low convergence directory resides makes no attempt to propagate updates and waits for the next skulk to synchronize the replica set.

A directory set to medium convergence is skulked at least once every 12 hours. If an update is made to the directory, the server that stores the master replica attempts to propagate the new information to the entire replica set. If the propagation fails, the server waits for the next skulk to synchronize the replica set.

A directory set to high convergence is skulked at least once every 12 hours. If an update is made to the directory, the server that stores the master replica attempts to propagate the new information to the entire replica set. If this update propagation fails, the server schedules a skulk of the directory to begin within the hour. If this initial skulk fails, additional skulks are initiated at 1-hour intervals until the skulk succeeds.

Note

The high-convergence setting is intended only for temporary use such as for troubleshooting. Directories that are permanently set to high convergence can, in certain cases, cause extensive network and memory usage.

Every newly created directory inherits the convergence value of its parent directory. The root directory of a namespace defaults to a convergence value of medium at its creation. Unless you change this value (or the convergence value of any lower-level directories after you create them), all directories that you create under the root will also default to medium. For most directories, you should never need to modify this value. However, you may occasionally find it useful to set a directory's convergence to high or low.

Before You Modify a Directory's Convergence

Use the `show directory` command and specify the `DNS$Convergence` attribute to verify the current value of the directory's convergence.

To Modify a Directory's Convergence

You must have write access to the directory whose convergence you intend to modify.

Use the `set directory` command to assign a value of high, medium, or low to a directory's `DNS$Convergence` attribute.

Examples

The following command sets the convergence value of the `.sales` directory to high.

```
dns> set directory .sales dns$convergence = high
```

The following command sets the convergence value of the `.mfg` directory to low.

```
dns> set directory .mfg dns$convergence = low
```

Chapter 8. Viewing the Structure and Contents of a Namespace

This chapter explains how to use the DECDns Control Program to display namespace information. (You can also use the Browser utility to display namespace information, as explained in Appendix H; however, the Browser utility is not supported by VSI.)

The DECDns Control Program provides two basic display commands, `show` and `directory`, you can use to view namespace structure and contents.

With the `show` command, you can display:

- Current status of a clerk, server, or clearinghouse
- Current values of any or all attributes associated with any directory, object, link, group, or child pointer

With the `directory` command, you can display a list of names that match the name you specify in the command.

To use the `show` and `directory` commands, you must have read access to the name you want to display.

Note

You also need the NET\$EXAMINE rights identifier to use `show` commands you direct to clerks and servers and their subentities. See Chapter 11 for complete information.

This chapter covers the following topics:

- Using prepositional phrases in `show` and `directory` commands (Section 8.1)
- Using the `show` command (Section 8.2)
- Using the `directory` command (Section 8.3)

8.1. Using Prepositional Phrases in `show` and `directory` Commands

You can use prepositional phrases to redirect a command's output and to qualify commands that contain wildcard characters. For example, with the `to file [=] filename` phrase, you can redirect the output of a command to a file on disk. You can use the `with attribute` phrase to limit the action of a command to affect only those entities that have the attribute value you specify. See Chapter 11 for descriptions of the prepositional phrases you can use with the `show` and `directory` commands.

8.2. Using the `show` Command

With the `show` command, you can display the directories stored in a clearinghouse and the current values of any or all of the attributes associated with a directory, group, link, object, or child pointer.

The basic syntax of all `show` commands is as follows:

```
show entity entity-name
```

where *entity* is the type of DECdns entity about which you want to display information and *entity-name* is a complete directory specification terminating with a simple name (the full DECdns name of the entity). You can use this command with any of the following entities:

- Child
- Clearinghouse
- Directory
- Group
- Link
- Object

You cannot use wildcard characters within the directory specification, but you can use wildcard characters in the terminating (rightmost) simple name.

Variations of the `show` command using attribute specifiers and attribute groups are described in the following list:

- `show entity entity-name`

Displays the current values of all identifier attributes associated with the entity you specify. (If the entity you specify does not maintain any identifier attributes, all attributes are displayed.)

- `show entity entity-name all`

Displays the current values of all the attributes (identifiers, characteristics, counters, and status) associated with the entity you specify. Not all entities maintain attributes from all four categories. See Chapter 11 for complete listings of the attributes associated with each DECdns entity.

- `show entity entity-name all characteristics`

Displays the current values of all characteristic attributes associated with the entity you specify.

- `show entity entity-name all counters`

Displays the current values of all counter attributes associated with the entity you specify.

- `show entity entity-name all status`

Displays the current values of all the status attributes associated with the entity you specify.

- `show entity entity-name attribute-name`

Displays the current value of a particular attribute associated with the entity you specify. To display values of multiple attributes in one command, separate the attribute names with commas on the command line.

You can combine multiple `all`, `all characteristics`, `all counters`, `all status`, and `attribute` qualifiers in a single command. Separate them with commas.

Examples

The following command displays the current values of all attributes associated with the clerk on the local node:

```
dns> show dns clerk all
```

```
Node 0 DNS Clerk
AT 2019-04-29-10:38:48.306-04:00I0.102
```

Status

```
State = On
```

Characteristics

```
Version = V2.0.0
Clerk Timeout = 0-00:01:00.000I0.000 Seconds
Solicit Holddown = 0-00:00:15.000I0.000 Seconds
UID = 32A56750-059F-11CA-B98E-08002B0DC09D
Default Namespace = IAF
```

Counters

```
Creation Time = 2019-04-28-22:54:24.163+00:00I0.000
Incompatible Protocol Errors = 0
Authentication Failures = 0
Read Operations = 1194
Cache Hits = 364
Cache Bypasses = 830
Write Operations = 293
Miscellaneous Operations = 0
```

The following command displays the current values of all attributes associated with the server running on the local node:

```
dns> show dns server all
```

```
Node 0 DNS Server
AT 2019-04-29-10:42:07.717-04:00I0.108
```

Status

```
State = On
```

Characteristics

```
UID = 3E6475F4-059F-11CA-B98E-08002B0DC09D
Minimum Protocol Version = V1.0.0
Maximum Protocol Version = V2.0.0
Future Skew = 0-00:05:00.000I0.000 Seconds
```

Counters

```
Creation Time                = 2019-04-28-22:54:43.725+00:00IO.000
Incompatible Protocol Errors = 0
Authentication Failures     = 0
Read Accesses                = 491
Write Accesses               = 211
Skulks Initiated             = 12
Skulks Completed             = 12
Times Lookup Paths Broken    = 0
Possible Cycles              = 0
Crucial Replica Removals Backed Out = 0
Child Pointer Update Failures = 0
Security Failures            = 0
```

8.3. Using the directory Command

You can use the `directory` command to display a list of names that match the name you specify in the command or to display a list of the object entries, soft links, and child pointers in a directory.

The basic syntax of all `directory` commands is as follows:

```
directory entity entity-name
```

where *entity* is the type of entity for which you are searching and *entity-name* is a complete directory specification terminating with a simple name. You can use this command with any of the following entities:

- Child
- Clearinghouse
- Directory
- Group
- Link
- Object

You cannot use wildcard characters within the directory specification, but you can use wildcard characters in the terminating (rightmost) simple name.

Examples

The following command displays the names of all the objects stored in the `.eng` directory:

```
dns> directory object .eng.*

    DIRECTORY
    OBJECT   IAF: .eng
    AT      13-JUL-2019:18:45:00

sales_group
test_group
triton
work_disk1
```

work_disk2

The following command displays the names of all the objects stored in the `.eng` directory whose names begin with the letter `t`.

```
dns> directory object .eng.t*
```

```
    DIRECTORY
    OBJECT   IAF:.eng
    AT      13-JUL-2019:18:46:00
```

test_group

triton

Chapter 9. Restructuring a Namespace

Over time, you may need to restructure or create alternative names for certain elements of your namespace. For example, you can create soft links to provide users with one or more alternative names for an existing namespace entry. You can reconfigure a directory's replica set to modify the locations and types of particular replicas, or exclude a replica from the set. Occasionally, you may want to delete certain directories when the information they contain is no longer needed by users. You may want to merge or append directories to reflect organizational changes. You may also need to relocate or delete a clearinghouse from a server system to perform diagnostic or troubleshooting work on the system, or to prepare for removing the system from your network.

This chapter explains how to perform the following namespace-restructuring tasks:

- Managing soft links (Section 9.1)
- Modifying a directory's replica set (Section 9.2)
- Deleting directories (Section 9.3)
- Merging directories (Section 9.4)
- Relocating a clearinghouse (Section 9.5)
- Deleting a clearinghouse (Section 9.6)

9.1. Managing Soft Links

A soft link is an alternative name, or synonym, with which you can refer to another existing name in a namespace. Soft links allow users and client applications to refer to a particular directory, object entry, or soft link by more than one name.

In general, you should create soft links only to assign alternative names to particular network resources, or to make minor changes to the original names of directories in your namespace hierarchy. To avoid confusion, follow these general guidelines when creating and managing soft links:

- Do not use soft links to completely redesign your directory hierarchy or to change the names of multiple directories at different levels.
- Do not create soft links only to provide abbreviations for long names that are difficult to remember or type. System environment variables and logical names are available for that purpose.
- Avoid creating long chains of soft links in which one soft link points to another soft link which, in turn, points to another soft link, and so on.

9.1.1. Creating a Soft Link

To create a soft link, you must have write access to the directory in which you intend to create the soft link.

Use the `create link` command to create a soft link with the link name you specify. Use the required `destination` argument to specify the soft link's destination name (the existing name to

which the new soft link will point). You can specify any name in the namespace as the destination name, including another soft link.

If you create a soft link that points to another soft link, be careful not to create a soft link loop where the destination name you specify eventually points back to the new soft link's own link name.

Using Optional Arguments

[*expiration*]

All soft links you create are permanent and never expire unless you use the optional *expiration* argument. You can use this argument to specify a future date and time when the name service will examine the soft link to make sure that the destination name to which it points still exists. If the destination name cannot be found (has already been deleted) when the expiration date is reached, DECdns automatically deletes the soft link. Enter the expiration time value using the *yyyy-mm-dd-hh:mm:ss* format. For example, *expiration 2019-01-25-16:00:00* indicates that DECdns will check to see if the target of the soft link still exists on January 25, 2019, at 4:00 p.m. If, at that time, the destination name cannot be found, DECdns deletes the soft link.

[*extension*]

If you specify an expiration value, you can also use the optional *extension* argument to specify a period of time to be added to the expiration date and time that you assigned. Enter the extension time value using the *ddd-hh:mm:ss* format. For example, *extension 030-00:00:00* indicates that, if the destination name of the soft link still exists when the assigned expiration date and time are reached, DECdns allows another 30 days to pass before it again checks for the existence of the destination name. If, at that time, the destination name cannot be found, DECdns deletes the soft link.

Examples

The following command creates a permanent soft link named `.sales.asia` that points to a directory named `.sales.eur`.

```
dns> create link .sales.asia destination .sales.eur
```

The following command creates a soft link named `.mfg.robot1` that points to an object entry named `.mfg.robotics_controller03`:

```
dns> create link .mfg.robot1 destination .mfg.robotics_controller03 -  
-> expiration 2019-12-12-09:00:00
```

In the preceding command, the expiration value indicates that DECdns will check to make sure that the destination name `.mfg.robotics_controller03` still exists on December 12, 2019, at 9:00 a.m. If the destination name cannot be found, DECdns deletes the soft link. If the destination name exists, but no extension value has been assigned, DECdns deletes the soft link.

The following command creates a soft link named `.admin.linka` that points to an object entry named `.sales.discount_stats`.

```
dns> create link .admin.linka destination .sales.discount_stats -  
-> expiration 2019-01-11-12:00:00 extension 090-00:00:00
```

In the preceding command, the expiration value indicates that DECdns will check to make sure that the destination name `.sales.discount_stats` still exists on January 11, 2019, at 12:00 p.m. If the destination name does not exist, DECdns deletes the soft link. If the destination name still exists, DECdns will check for the existence of the destination name after a period of 90 days, as specified

in the command's `extension` argument. If, at that time, the destination name cannot be found, `DECdns` deletes the soft link.

9.1.2. Changing a Soft Link's Destination Name

To change a soft link's destination name, you must have write access to the soft link.

Use the `set link` command to specify a new value for a soft link's `DNS$LinkTarget` attribute and redirect the soft link from its current destination name to some other name in the namespace.

Example

The following `set link` command redirects a soft link named `.admin.work_disk` from its current destination name to a new destination name `.admin.work_disk03`.

```
dns> set link .admin.work_disk dns$linktarget .admin.work_disk03
```

9.1.3. Changing a Soft Link's Expiration or Extension Time

To change a soft link's expiration or extension time, you must have write access to the soft link.

Use the `set link` command to specify a new value for either or both the expiration and extension times currently stored in a soft link's `DNS$LinkTimeout` attribute. Even if you want to modify only one of the values, you must specify values for both expiration and extension in your command. You specify a new value in the same format used to establish the original value. Specify an expiration value in the `yyyy-mm-dd-hh:mm:ss` format, and an extension value in the `ddd-hh:mm:ss` format.

Examples

The following `set link` command sets the expiration time of a soft link named `.eng.link01` to December 31, 2019, at 12:00 p.m. In this example, zero extension value (no extension) is currently assigned to the soft link.

```
dns> set link .eng.link01 dns$linktimeout -  
_> (2019-12-31-12:00:00 000-00:00:00)
```

The following command sets the expiration time of a soft link named `.eng.link01` to December 31, 2019, at 12:00 p.m. and sets the soft link's extension value to 90 days:

```
dns> set link .eng.link01 dns$linktimeout -  
_> (2019-12-31-12:00:00 090-00:00:00)
```

9.2. Modifying a Directory's Replica Set

A directory's replica set always contains a master replica, and can also contain other read-only replicas. The values stored in the `DNS$Replicas` attribute associated with a directory contain information that describes the directory's replica set, including how many replicas exist, their replica types, and the name of the clearinghouse where each of the replicas is stored. You can use the `set directory to new epoch` command to overwrite the current values stored in the directory's `DNS$Replicas` attribute and perform either or both of the following operations in a single command:

- Redesignate the master replica in a directory's replica set (Section 9.2.1).
- Exclude a replica from a directory's replica set (Section 9.2.2).

You do not need to modify a directory's replica set when you create or delete read-only replicas; the normal skulking process for the directory will distribute these modifications to all members of the replica set automatically.

Before You Modify a Directory's Replica Set

Before you can modify a directory's replica set, you need to know how many replicas exist, the replica type of each replica, and the name of the clearinghouse where each of the replicas is stored. The command you use to modify a directory's replica set prevents you from accidentally leaving a replica out of the new set. You must explicitly list all existing replicas in the set. You can include or exclude any replica from the new set, but you must account for all replicas. Only one of the replicas that you include in the new set can be designated as the master replica.

Use the `show directory` command and specify the directory's `DNS$Replicas` attribute to gather this information. See Chapter 8 for complete information on how to use the `show directory` command.

To modify a directory's replica set, you must have the following access:

- Read and control access to the directory
- Write access to each clearinghouse that stores a replica of the directory

Note

If the directory is replicated in both Version 1 (DNS Version 1) and Version 2 (DECdns Version 2) clearinghouses, make sure that both Version 1 and Version 2 ACEs exist on the directory and all of the directory's contents before you try to set the new epoch. See Section 5.1.1 and Section 5.1.2 for information on how to specify Version 2 and Version 1 principals in ACEs.

After You Modify a Directory's Replica Set

After you use the `set directory to new epoch` command, DECdns automatically initiates a special skulk of the directory. This skulk may require more time to complete than other regularly scheduled skulks and will require more network resources.

9.2.1. Changing the Replica Type of a Replica

For configuration management reasons, you may want to designate a different replica as a directory's master replica when:

- A server system whose clearinghouse contains a master replica will be down for an extended period of time or removed permanently from the network.
- A clearinghouse that stores a master replica is going to be deleted from the namespace.
- You want to locate the master replica closer to where the majority of updates to the directory originate.

Use the `set directory to new epoch` command to designate a new master replica.

Example

In this example, the replica set of the `.eng` directory consists of three replicas: the master replica (stored in clearinghouse `.ny1_ch`), a read-only replica (stored in clearinghouse `.ny2_ch`), and a read-only replica (stored in clearinghouse `.chicago1_ch`), as shown in Figure 9.1.

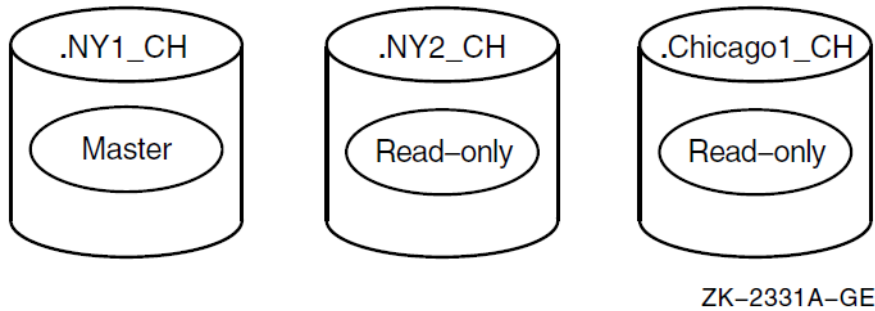
Figure 9.1. Example Replica Set

The following command designates the read-only replica (stored in clearinghouse `.chicago1_ch`) as the directory's new master replica, designates the former master replica (stored in clearinghouse `.ny1_ch`) as a read-only replica, and leaves the read-only replica (stored in clearinghouse `.ny2_ch`) as it is. Figure 9.2 shows the result of this command.

```
dns> set directory .eng to new epoch master .chicago1_ch, read-only -
_> .ny1_ch, read-only .ny2_ch
```

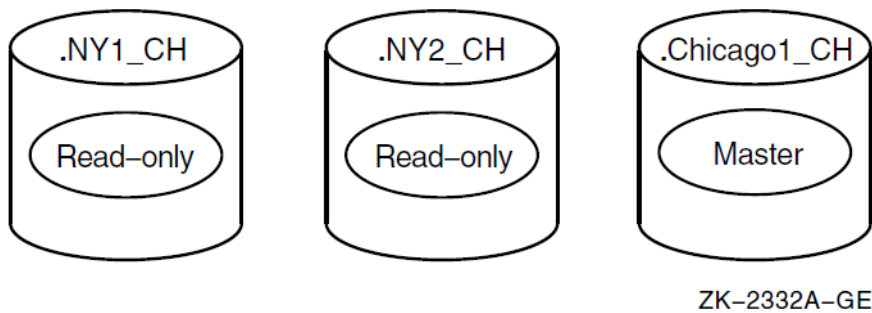
Figure 9.2. Example Replica Set After Master Redesignation

9.2.2. Excluding a Replica from a Replica Set

You can temporarily exclude a replica from its replica set when the clearinghouse in which the replica is stored unexpectedly becomes unavailable. Excluding this replica enables DECdns to complete skulks of the directory during the time the replica is unavailable. Base your decision when to exclude a replica on how long the clearinghouse where the replica is stored will be unavailable. For example, if a clearinghouse will be off line for only a few hours, or even for several days, you may not need to ensure that DECdns is able to complete skulks of the directories stored there. However, if a clearinghouse will be unavailable for several weeks or more, you may want to exclude the replicas stored there from their respective replica sets to make sure that new information can be updated to the other replicas in the sets.

Note

When you know in advance that a replica will become permanently unavailable because its clearinghouse is being removed from the network, you should delete the replica rather than temporarily exclude it from the replica set. You must delete the replica *before* the clearinghouse becomes unavailable. See Section 7.3 for complete information on using the `delete replica at clearinghouse` command.

Excluding a replica does not delete the replica; it only prevents the replica from being updated by a skulk. DECdns clerks and servers still use the excluded replica for lookups. You should reintroduce the excluded replica to its replica set as soon as possible after the clearinghouse on which it resides becomes available. Otherwise, lookup requests directed to the excluded replica may return outdated information.

Use the `set directory to new epoch` command with the optional `exclude` argument to rebuild a directory's replica set, excluding the replica that you specify. Remember that you must account for all existing replicas in the command.

Example

In this example, the replica set of the `.eng` directory consists of three replicas: the master replica (stored in clearinghouse `.chicago1_ch`) and read-only replicas (stored in clearinghouses `.ny1_ch` and `.ny2_ch`).

In this case, the `.ny1_ch` clearinghouse has been cut off from the network because of accidental damage to the network transmission lines. Connectivity to the clearinghouse will not be restored for several days. During this period, skulks of the `.eng` directory will fail unless you temporarily exclude the read-only replica stored in clearinghouse `.ny1_ch`.

To make it possible for skulks of the `.eng` directory to succeed during the repair period, you can enter the following `set directory to new epoch` command to overwrite the current values of the `.eng` directory's `DNS$Replicas` attribute with new values that include only the replicas stored in the `.ny2_ch` and `.chicago1_ch` clearinghouses:

```
dns> set directory .eng to new epoch master .chicago1_ch, read-only -
-> .ny2_ch, exclude .ny1_ch
```

Figure 9.3 shows the result of the preceding command.

Figure 9.3. Example Replica Set After Replica Exclusion

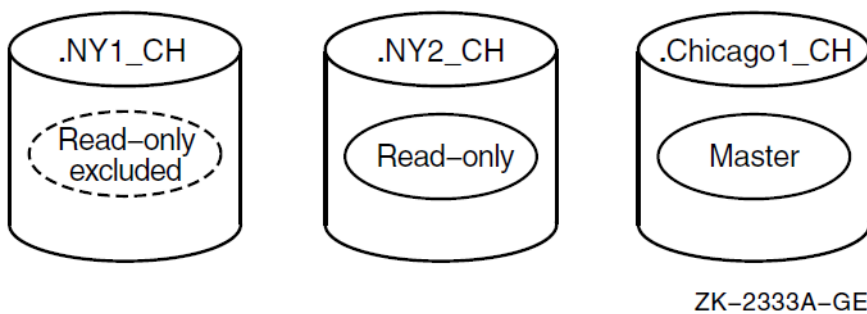

When connectivity with the `.ny1_ch` clearinghouse is reestablished, enter the following `set directory to new epoch` command to reintroduce the read-only replica stored in clearinghouse `.ny1_ch` to the replica set.

```
dns> set directory .eng to new epoch master .chicago1_ch, read-only -
-> .ny1_ch, read-only .ny2_ch
```

Note

You should always reintroduce excluded replicas to their replica sets as soon as possible after the clearinghouse in which they reside again becomes available. Otherwise, lookup requests directed to the excluded replicas in the clearinghouse may return outdated information.

9.3. Deleting Directories

You may sometimes want to delete directories from your namespace when the information they contain is no longer needed by users. DECdns provides two commands you can use to delete directories: `delete directory` and `delete subtree`. (A subtree can be a single directory and its contents, or a directory and all its child directories and their contents.)

When deleting directories, remember that DECdns does not permit you to delete a directory that stores clearinghouse object entries.

To delete a directory, you must have the following access:

- Read and delete access to the directory
- Write, delete, or control access to the directory's parent directory
- Write access to the clearinghouse that stores the master replica of the directory (or directories) you intend to delete

9.3.1. Deleting a Bottom-Level Directory

To delete a bottom-level directory (a directory that has no child directories), follow these steps:

1. Identify the clearinghouse locations of all replicas in the replica set of the directory you intend to delete. Use the `show directory` command and specify the `DNS$Replicas` attribute to display this information.
2. Use the `delete replica at clearinghouse` command to delete all the read-only replicas you found in step 1.
3. Use the `delete object` and `delete link` commands to delete the directory's contents.
4. Use the `delete directory` or the `delete subtree` command (nonrecursive mode) to delete the master replica of the directory from the namespace.

Example

The following sequence of commands deletes a directory named `.sales`. In this example, the contents of the `.sales` directory were already deleted, making step 3 of the above procedure unnecessary.

1. The following `show directory` command, specifying the `DNS$Replicas` attribute, displays the replica type and clearinghouse location of all replicas in the replica set of the `.sales` directory:

```
dns> show directory .sales dns$replicas
          SHOW
          DIRECTORY IAF:.sales
          AT 09-APR-2019:16:08:25
          DNS$Replicas (set) = :
          Clearinghouse's DNS$CTS = 2018-03-22-14:39:34.58/aa-00-04-00-
de-11
          Tower 1 CTS = 2018-04-09-20:08:25.835/08-00-2b-0d-
c0-9d
          Floor 1 = 01 2c (null)
```

```

        Floor 2 = 02 00 2c ncacn_dnet_nsp
        Floor 3 = 04 (null)
        Floor 4 = 06 49 00 37 aa 00 04 00 22 dc 20
    Replica type = master
    Clearinghouse's Name = IAF:.NY1_CH
    DNS$Replicas (set) = :
    Clearinghouse's DNS$CTS = 2018-07-30-20:32:42.82/aa-00-04-00-
de-11
        Tower 1 CTS = 2019-04-09-20:08:25.835/08-00-2b-0d-
c0-9d
        Floor 1 = 01 2c (null)
        Floor 2 = 02 00 2c ncacn_dnet_nsp
        Floor 3 = 04 (null)
        Floor 4 = 06 49 00 14 aa 00 04 00 7e 52 20
    Replica type = readonly
    Clearinghouse's Name = IAF:.NY2_CH
    DNS$Replicas (set) = :
    Clearinghouse's DNS$CTS = 2018-01-12-18:15:01.77/aa-00-04-00-
de-11
        Tower 1 CTS = 2019-04-09-20:08:25.835/08-00-2b-0d-
c0-9d
        Floor 1 = 01 2c (null)
        Floor 2 = 02 00 2c ncacn_dnet_nsp
        Floor 3 = 04 (null)
        Floor 4 = 06 49 00 33 aa 00 04 00 0a ce 20
    Replica type = readonly
    Clearinghouse's Name = IAF:.Chicago1_CH

```

The output of this command shows that the master replica of the `.sales` directory is stored in clearinghouse `.ny1_ch`, a read-only replica is stored in clearinghouse `.ny2_ch`, and another read-only replica is stored in clearinghouse `.chicago1_ch`.

- The following command deletes the read-only replica stored in clearinghouse `.ny2_ch`.

```
dns> delete replica .sales at clearinghouse .ny2_ch
```

The following command deletes the read-only replica stored in clearinghouse `.chicago2_ch`.

```
dns> delete replica .sales at clearinghouse .chicago2_ch
```

- With all read-only replicas deleted, the following command deletes the master replica of the `.sales` directory stored in clearinghouse `.ny1_ch`.

```
dns> delete directory .sales
```

9.3.2. Deleting a Subtree of Directories

You can use the recursive mode of the `delete subtree` command to delete the directory (and its contents) you specify, as well as all child directories (and their contents) that exist beneath it. Using this command provides a convenient way to delete an entire subtree of directories and saves you the effort of deleting the contents of each directory yourself.

You can use the recursive mode of the `delete subtree` command provided that the following conditions are satisfied:

- You have already deleted all read-only replicas of all the directories in the subtree that you intend to delete.

- No clearinghouse object entries exist in any of the affected directories.

Beginning at the lowest-level directory in the subtree you specify, the `delete subtree` command deletes the directory's contents, deletes its master replica, then moves up to the next directory in the subtree and repeats this process until all directories under and including the directory you specified are deleted.

Note

If a clearinghouse object entry is found in a directory, the recursive `delete subtree` command does not delete the clearinghouse object entry, the directory that contains it, or any directories further up that branch of the subtree. However, DECdns continues to delete other directories in other branches of the specified subtree that do not contain clearinghouse object entries.

Example

The following `delete subtree` command, using the recursion flag (`...`), deletes the `.sales` directory and its child directory `.sales.region1`:

```
dns> delete subtree .sales...
```

When you enter the command, DECdns deletes the contents of the `.sales.region1` directory, then deletes the master replica of the directory itself. DECdns then moves up to the `.sales` directory, deletes its contents, then deletes its master replica.

9.4. Merging Directories

Sometimes, because of corporate restructuring or other reasons, you may want to combine or rearrange various directories, or subtrees of directories, in your namespace.

For example, suppose the engineering group in your organization (`.eng`) is combined with the research and development group (`.rnd`) and that the two groups will begin to share a common set of network resources. You can reflect this organizational change in your namespace hierarchy by combining these directories. Similarly, if the engineering group becomes subordinate to the research and development group, you can reflect this change by creating an empty directory named `.rnd.eng` and then merging the contents of the `.eng` directory into `.rnd.eng`, thus appending `.eng` below `.rnd`.

9.4.1. Overview of the Merge Procedure

To merge or append directories, follow these steps:

1. Use the `dump subtree` command to create an interim file containing the information you intend to merge or append.
2. Merge the interim file you created in step 1 with another existing directory. Use the `merge file` command to combine the directory information in an interim file with another directory or to append the information below an existing bottom-level directory.

The master replica of a directory that you dump and then merge with another directory is stored in the clearinghouse that stores the master replica of the directory with which (or below which) you merge the dumped directory.

For example, if you dump the `.eng` directory to the interim file and then merge the interim file with the `.rnd` directory, the master replica of the `.eng` directory is stored in the clearinghouse that stores the master replica of the `.rnd` directory.

3. Delete the directory or subtree (and contents) that you merged in step 2 from its old location in the hierarchy and replace the deleted directory information with a single soft link of the same name to redirect lookups of the information at its new location. See Section 9.3 for information on how to delete a directory. See Section 9.1.1 for information on how to create a soft link.

If a directory or subtree that you merge stores a clearinghouse object entry, you may prefer to use the `replace subtree` command to perform this step. See Section 9.4.4 and Chapter 11 for more information on the `replace subtree` command.

Note

The presence of duplicate names, unreachable names, clearinghouse object entries, groups, and node object entries in a merged directory requires special handling. See Section 9.4.4 to Section 9.4.7 for details on merging directories that contain these elements. The basic merge and append operations described in the following sections assume that no clearinghouse object entries, groups, or node object entries exist in the source directory and that no duplicate or unreachable names exist in either the source or target directory.

9.4.2. Basic Merge and Append Operations

The following merge and append operations are based on a sample namespace (Figure 9.4) that consists of two directories under the root: `.eng` and `.rnd`. The source directory (`.eng`) contains two object entries: `.eng.obj1` and `.eng.link1`. The target directory (`.rnd`) also contains two object entries: `.rnd.obj2` and `.rnd.link2`.

Figure 9.4. Example Namespace Hierarchy

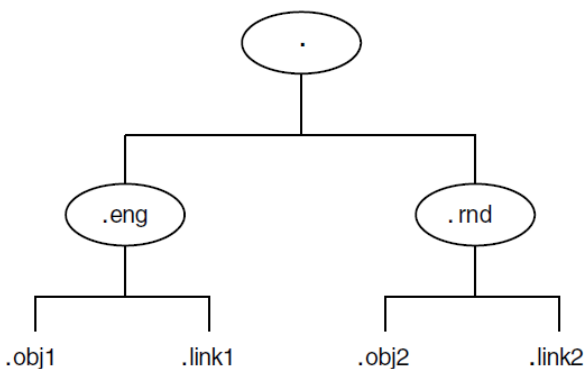

ZK-2619A-GE

9.4.2.1. Performing a Basic Merge Operation

The following procedure merges the source directory `.eng` into the target directory `.rnd`. Step 3 of the procedure deletes the merged `.eng` directory from its original location and replaces it with a soft link to redirect lookups of `.eng` to the `.rnd` directory.

1. The following `dump subtree` command creates an interim file named `eng.dat` that contains the `.eng` directory and its contents, `.eng.obj1` and `.eng.link1`.

```
dns> dump subtree .eng into file eng.dat
```

Note

The `.dat` extension of the interim file `eng.dat` is added to the file name only to avoid confusion in the following example commands. File extensions are not required in the names of interim files. An interim file is a printable ASCII file.

The `dump subtree` command can take some time to execute, especially if you are dumping large subtrees that contain many names. The clearinghouses that store the master replicas of the directories in the subtree you specify must all be enabled and reachable when you enter the command. Otherwise, the command fails and an error message is displayed explaining the reasons for the failure. The interim file contains only the directory information that was successfully dumped before the error occurred.

- The following `merge file` command merges the interim file you created in step 1 (`eng.dat`) with the `.rnd` directory. The `failures to file` argument copies, to a failures file named `failures.dat`, any names that cannot be reached (and therefore cannot be created) when you enter the command. In this example, it is assumed that all affected files were successfully merged. See Section 9.4.5 for more information on using the failures file.

```
dns> merge file eng.dat into subtree .rnd failures to file -
_> failures.dat
```

Figure 9.5 shows the structure of the example namespace before and after this merge operation.

Figure 9.5. Example Namespace Before and After the Merge Operation

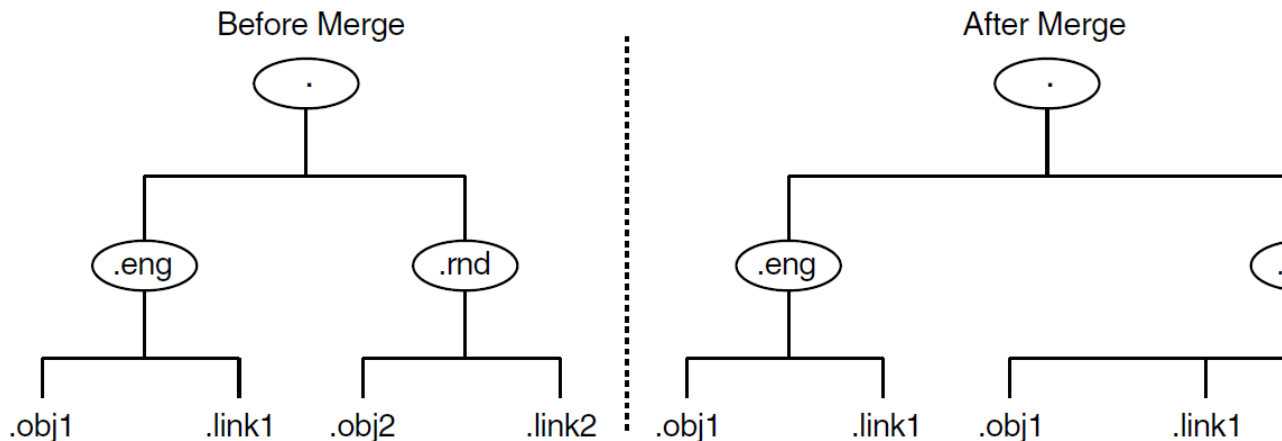

- After the merge operation, the `.eng` directory (and its contents) still exists at the source location. The following commands delete the `.eng` directory from its original location and then create a soft link named `.eng` in place of the deleted directory. This soft link redirects lookups of `.obj1` and `.link1` to their new locations in the `.rnd` directory.

```
dns> delete subtree .eng...
dns> create link .eng destination .rnd
```

9.4.2.2. Performing a Basic Append Operation

The following procedure merges the source directory `.eng` into the empty target directory `.rnd.eng` (that is, appends the `.rnd` directory under the `.eng` directory). Step 4 of the procedure deletes the merged `.eng` directory from its original location and replaces it with a soft link to redirect lookups of `.eng` to the `.rnd` directory.

1. The following `dump subtree` command creates an interim file named `eng.dat` that contains the `.eng` directory and its contents, `.eng.obj1` and `.eng.link1`.

```
dns> dump subtree .eng into file eng.dat
```

2. The following `create directory` command creates a new empty directory named `.rnd.eng`.

```
dns> create directory .rnd.eng
```

3. The following `merge file` command merges the interim file you created in step 1 (`eng.dat`) with the new `.rnd.eng` directory. The `failures to file` argument copies, to a failures file named `failures.dat`, any names that cannot be reached (and therefore cannot be created) when you enter the command. In this example, it is assumed that all affected files were successfully merged. See Section 9.4.5 for more information on using the failures file.

```
dns> merge file eng.dat into subtree .rnd.eng failures to file -
_> failures.dat
```

Figure 9.6 shows the structure of the example namespace before and after this append operation.

Figure 9.6. Example Namespace Before and After the Append Operation

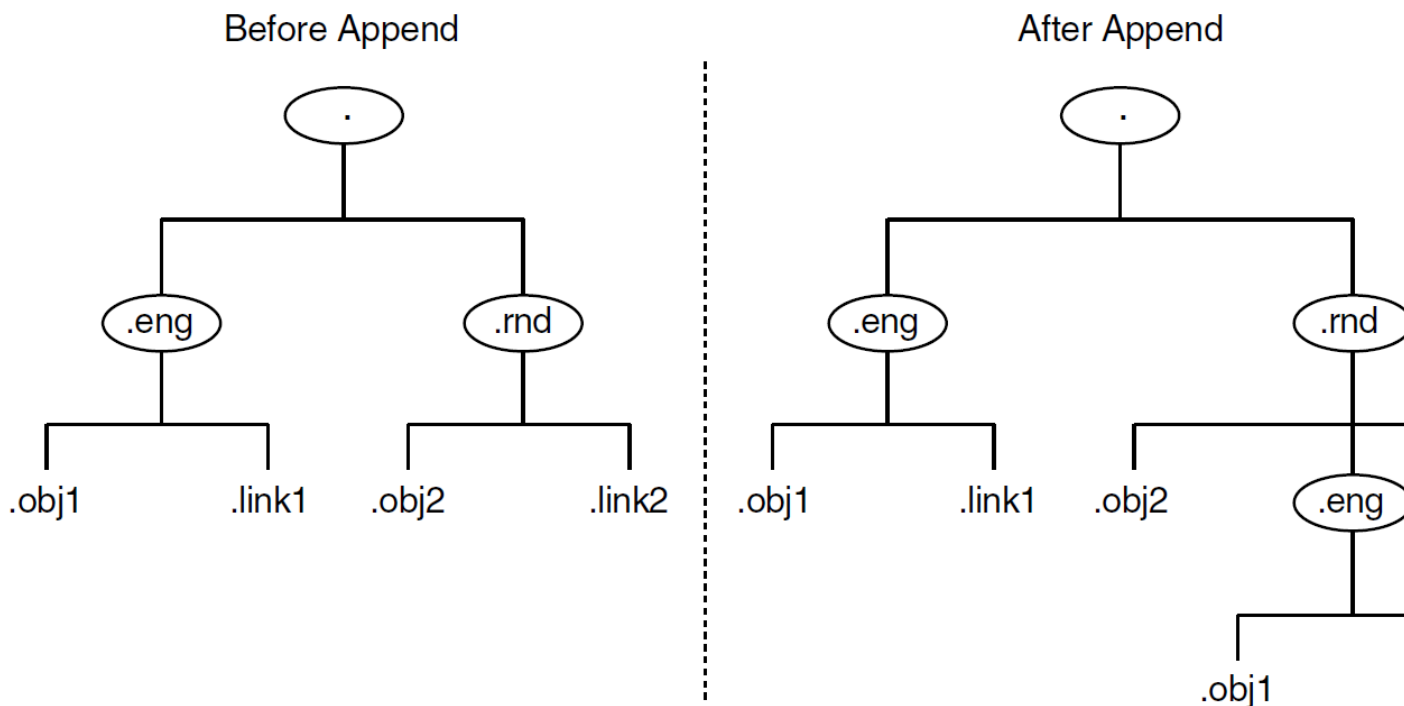

4. After the append operation, the `.eng` directory (and its contents) still exists at the source location. The following commands delete the `.eng` directory from its original location and then create a soft link named `.eng` in place of the deleted directory. This soft link redirects lookups of `.obj1` and `.link1` to their new locations in the `.rnd.eng` directory.

```
dns> delete subtree .eng...
```

```
dns> create link .eng destination .rnd.eng
```

9.4.3. Merging Directories with a Single Command

Although not always appropriate, you may sometimes be able to use the `merge subtree` command to merge or append directories. The `merge subtree` command combines step 1 (`dump subtree`) and step 2 (`merge file`) of a merge operation into a single command. See Section 9.4.2 for information on how to use these commands individually.

You can use the `merge subtree` command when you are sure that the following two conditions are satisfied:

- No duplicate names exist in the source and target directories.
- All clearinghouses that store master replicas of affected directories (at both the source and target locations) are running and reachable when you enter the command.

If a duplicate name is detected, or if any affected clearinghouse cannot be reached while the `merge subtree` command is in progress, the affected entries are not merged. In this case, the `merge subtree` command creates a named interim file or failures file with a randomly generated name in the current directory. Errors are reported only to your screen.

If the merge operation is incomplete, you can delete the partially merged information at the target location. Then reenter the command after you delete any duplicate names and are certain that connectivity to the affected clearinghouses can be maintained.

Example

The following `merge subtree` command (which produces the same result as steps 1 and 2 in Section 9.4.2.1) merges the `.eng` directory with the `.rnd` directory. This example assumes that no duplicate names exist and the master replicas of all affected directories are reachable.

```
dns> merge subtree .eng into subtree .rnd
```

9.4.4. Handling Clearinghouse Object Entries

Merge and append operations affect only directories, application-defined object entries, node object entries, and groups. They do not affect clearinghouse object entries or the actual clearinghouses those object entries represent. Any clearinghouse object entries that exist in the directory or subtree you specify in a `dump subtree` command are not copied to the interim file. Clearinghouse object entries cannot be merged because to do so would interrupt the connectivity of the namespace.

After a merge operation, do not delete a clearinghouse object entry, and the source directory in which it resides, unless you also intend to abandon use of the clearinghouse that the clearinghouse object entry represents.

If a directory that you merge contains a clearinghouse object entry (and you want to preserve the associated clearinghouse), you cannot delete the directory and replace it with a single soft link. Instead, you must delete only the contents of the directory (except the clearinghouse object entry) and replace each name with a soft link of the same name to redirect lookups to the target location. To save time and effort, you can use the `replace subtree` command to complete these tasks with a

single command. The `replace subtree` command deletes only a directory's contents (except for clearinghouse object entries and the directories that contain them) and creates individual soft links for every name in the source directory that was merged. These soft links redirect lookups of the names from their old (source) locations to their new (target) locations. Using this command preserves both the clearinghouse object entry and the directory that contains it while deleting the directory's contents and replacing each name with an individual soft link.

9.4.5. Using the Failures File

Use the `merge file` command's `failures to file` argument to save a copy of directory and name information that could not be merged. A failures file can contain the following information:

- Duplicate names detected during the merge operation
- Names in the source subtree stored in clearinghouses that were not reachable when the command was executing

You can use this information as an index of the names that could not be merged or, when appropriate, you can merge the failures file itself on a subsequent merge operation.

Section 9.4.5.1 and Section 9.4.5.2 explain how to deal with duplicate names and failures caused when names to be merged are unreachable.

9.4.5.1. Handling Duplicate Names

If the full name of a source directory, object entry, or soft link is identical to a full name of a target directory, object entry, or soft link, the `merge file` command does not merge the duplicate source name. Duplicate names are not merged, to avoid overwriting and destroying the identical names in the target directory.

The `failures to file` argument is especially useful in `merge file` commands that specify directories in which you know or suspect that duplicate names exist. During execution, the `merge file` command displays any duplicate names on your screen and copies them to the failures file.

If duplicate names exist, you need to decide which name you want to preserve: the name in the source or the name in the target. You can perform any of the following operations to eliminate a conflict:

- Delete the duplicate name in the target directory, then reenter the `merge file` command and specify the failures file (rather than the interim file) in the command's *ifile* argument.
- Delete the duplicate name from the source directory (the directory you dumped to the interim file) and keep only the name in the target directory. If you choose this solution, you do not need to use the failures file.
- Use the `recreate` commands to re-create a duplicate object entry, soft link, or directory in the source subtree as a new object entry, soft link, or directory in the target subtree. Then delete the duplicate name from the source subtree. New names that you create with these commands retain the same writable attribute values as the existing duplicate names on which they are based. The commands do not delete or modify the existing names. An additional ACE is created for the new name (in the target subtree) that grants the creator full access to the name. The new name also inherits any existing default ACEs that may be propagated from the parent directory (the directory in which you recreate the name) in the target subtree. The name that you assign to the new directory, object entry, or soft link in the target subtree must be different from the name of the existing directory, object entry, or soft link in the source subtree.

Note

The `recreate` commands are also useful for creating new object entries whose user-defined, writable attributes (with the exception of the `DNS$ACS` attribute) are identical to those of an existing application-defined object entry. This is especially useful when the existing object entry maintains many writable attributes whose values you would otherwise have to assign individually with the `set object` command.

See Chapter 11 for more information on using the `recreate` commands.

9.4.5.2. Handling Unreachable Name Failures

Sometimes, a clearinghouse that stores the master replica of a directory you are trying to merge is disabled or unreachable when you enter the `merge file` command. When this happens, `DECdns` is unable to create the name at the target location.

When unable to merge a name for this reason, the `merge file` command copies the name to the failures file and displays an error message specifying the name that could not be created. By maintaining a log of these messages, you can identify failures that were caused by name conflicts as opposed to failures that were caused because a name was unreachable or could not be created.

9.4.6. Adjusting Access After a Merge

When the name of a node changes, the principal specifications (*nodename.username*) for all users with accounts on that node also change. All existing ACEs whose principals refer to users on the old node name are invalid. For example, suppose that directory `.eng` is merged with directory `.rnd`. Before the merge, user `smith`, whose login account was on node `.eng.orion`, was specified as a principal in ACEs throughout the namespace as `.eng.orion.smith`. After the merge, Smith's new principal specification becomes `.rnd.orion.smith`, invalidating all existing ACEs that specify `.eng.orion.smith` as a principal. Until you replace the old principal with the new principal in these ACEs, Smith will be denied the required access. You can use the `change subtree access` command to substitute a new principal for an invalidated principal in all affected ACEs with a single command. See Section 5.7.1 for information on how to use this command.

Updating Merged Group Names

When you merge an access control group, you change the full `DECdns` name of the group. Because such a group name is specified as a principal in ACEs throughout a namespace, changing its name renders all ACEs that refer to the group by its original name unable to convey access.

For example, suppose a group named `.eng.group1` is specified as a principal in ACEs throughout the namespace. If you append the `.eng` directory below the `.rnd` directory, the full name of the group becomes `.rnd.eng.group1`. Until you update the principal specification in all ACEs that refer to `.eng.group1` with the new name `.rnd.eng.group1`, members of the group are denied the access they need.

You can use the `change subtree access` command to update a group name in the principal specification of all affected ACEs. The following `change subtree access` command replaces the old group name `.eng.group1` with the new group name `.rnd.eng.group1` in all ACEs that refer to the old group name throughout the entire namespace:

```
dns> change subtree ... access .eng.group1 .rnd.eng.group1
```

See Section 5.7.1 for additional examples of the `change subtree access` command.

If a merged group itself is specified as a member of another existing group, you also need to update the group member specification in that group to reflect the new name of the group member. For example, suppose the group `.eng.group1` is a member of a group named `.rnd.group2`. If you merge the `.eng` directory with the `.rnd` directory, the name `.eng.group1` becomes `.rnd.group1`. However, because group `.rnd.group2` still refers to `.eng.group1` as a member, you need to update the old group member specification with the new group member specification in group `.rnd.group2`. Since the old group name (`.eng.group1`) may also be a member of other groups in the namespace, you need to update the old group member specification in all affected groups.

You can use the `change subtree group member` command to replace an existing group member with a new group member in all access control groups named in the directory or subtree you specify. The following command replaces the old group member `.eng.group1` with the new group member `.rnd.group1` in all groups in the namespace, including `.rnd.group2`.

```
dns> change subtree ... group member .eng.group1 .rnd.group1
```

See Section 5.6.3 for additional examples of the `change subtree group member` command.

9.4.7. Handling Changed Node Object Entries

When you merge a node object entry, you change the name of the node that the node object entry represents. For most types of object entries, deleting the merged name from the source location and replacing it with a soft link of the same name that points to the new name is sufficient to maintain usability of the object entry. However, because a merged node object entry no longer matches the node name of the actual system, you need to edit the DECnet startup script on the system, resetting the node name in the script to match the new name of the node object entry.

9.4.8. Merging Two Namespaces

In general, the procedure you follow to merge two namespaces is the same as the procedure you use to merge two directories or subtrees within the same namespace. However, there are some additional restrictions:

1. You must include the nickname and root directory (`.`) of the source namespace in step 1 (`dump subtree`). See Section 9.4.2.1.
2. You must include the nickname of the target namespace in step 2 (`merge file`). See Section 9.4.2.1.
3. Both namespaces are likely to contain the following four DECnet node directories created with the node registration tool:
 - `.DNA_Node`
 - `.DNA_NodeSynonym`
 - `.DNA_BackTranslation`
 - `.DTSS_GlobalTimeServers`

Because these directories reside directly beneath the root directory in both namespaces, they are duplicate names and are not merged in the initial merge operation. To merge these directories, you

must create a separate interim file for each source directory, then merge each file individually with its counterpart in the target namespace.

You may also need to resolve duplicate node synonym conflicts. Backtranslation conflicts should not occur as long as all nodes in the network have unique addresses. (See the DECnet-Plus configuration and network management documentation for your operating system for more information on these directories.)

4. In step 3 of a namespace merge operation, you must delete all directories that exist directly below the root of the source namespace and replace them with individual soft links that point to their new locations in the target namespace. Be sure to include the target namespace nickname in the soft link's destination name (`DNS$LinkTarget` attribute).
5. After the merge operation, complete the following tasks in the target namespace:
 - a. Update the principal specifications in all ACEs associated with merged names. Replace the source namespace nickname with the target namespace nickname. You can use the `change subtree access` command to perform this operation with a single command. See Section 5.7.1 for information on how to use this command.
 - b. In the DECnet node directories `.DNA_NodeSynonym` and `.DNA_BackTranslation`, update the destination name of each merged soft link. Replace the source namespace nickname with the target namespace nickname in each soft link's `DNS$LinkTarget` attribute. Use the `set link` command to make these modifications.

9.5. Relocating a Clearinghouse

Occasionally, you may need to relocate a clearinghouse from the server system where it currently resides to another server system. For example, you may want to move a clearinghouse when:

- You need to temporarily disconnect the host server system from the network for repair or for other reasons.
- You no longer want the current host system to function as a DECdns server.
- You want to move the clearinghouse to a server system that is physically closer on the network to the user groups and applications that use the information contained in the clearinghouse.

To relocate a DECdns Version 2 clearinghouse, use the following procedure:

1. For the server to which you intend to move the clearinghouse (the destination server system), grant the following DECdns access to the clearinghouse:
 - a. For the `DNS$Server` principal on the server, grant read, write, delete, test, and control access to the clearinghouse and the object. Specify the principal as `nodename.dns$server`, where `nodename` is the full DECdns name of the node on which the server is running.
 - b. For the `system` account, grant read, write, delete, test, and control access to the clearinghouse. Specify the principal as `nodename.system`.
2. Dissociate the clearinghouse from the server where it is currently running.
3. Copy the clearinghouse database files from their current location (source server system) to their new location (target server system).

4. Create a new clearinghouse on the target server system using the same name used on the source server system from which you copied the database files.
5. Enable the relocated clearinghouse at the target server.

9.5.1. Dissociating a Clearinghouse from Its Host Server System

Whenever a DECdns server is enabled, one of the tasks the server software performs is to enable its clearinghouse (or clearinghouses). The server performs this task automatically by examining its list of the clearinghouses resident on the system. As the first task in relocating a clearinghouse, you must:

1. Disable the clearinghouse with the `disable dns server clearinghouse` command. This command places the clearinghouse in a safe state and prohibits further transactions against it.

To use the `disable dns server clearinghouse` command, you must have the NET \$MANAGE rights identifier.

2. Use the `clear dns server clearinghouse` command to remove, from the server's internal memory, the clearinghouse you specify. This ensures that the clearinghouse is not automatically enabled on server restarts (even if the clearinghouse files are not deleted).

To use the `clear dns server clearinghouse` command, you must have the NET \$MANAGE rights identifier.

Example

The following `disable dns server clearinghouse` command disables the clearinghouse `.chicago2_ch`.

```
dns> disable dns server clearinghouse .chicago2_ch
```

The following `clear dns server clearinghouse` command removes knowledge of clearinghouse `.chicago2_ch` from the memory of its host server:

```
dns> clear dns server clearinghouse .chicago2_ch
```

9.5.2. Copying the Clearinghouse Database Files to the Target Server System

After you disable the clearinghouse and remove knowledge of the clearinghouse from the host server, you must copy the clearinghouse database files to a specific location on the new host server system.

A clearinghouse database consists of the following three files, where *nnnnnnnnnn* represents an 10-digit number:

- *clearinghouse-name.checkpointnnnnnnnnnn*
- *clearinghouse-name.tlognnnnnnnnnn*
- *clearinghouse-name.version*

These files reside, by default, in the `SYS$SYSDEVICE:[DNS$SERVER]` account. (If the clearinghouse was created with DNS Version 1 software and later converted to DECdns Version 2 format, the clearinghouse files reside, by default, in the `SYS$SYSROOT:[DNS$SERVER]` account.)

Actual clearinghouse file locations may vary from one system to another if they were created explicitly or moved to a different location. You should verify the existence of these three files before you attempt to copy them to the new host system.

Note

You may sometimes find two `.checkpointnnnnnnnnnn` files in the directory. This can happen as a result of a system crash, or other interruption, during the clearinghouse's most recent checkpoint operation. If you do find two files, copy both of them to the target server system. The server software on that system will automatically reconcile any problem that may exist as soon as the clearinghouse is enabled at the target server.

9.5.3. Re-creating and Enabling the Clearinghouse on the Target Server

After copying the clearinghouse database files to the appropriate location on the target server system, use the `create dns server clearinghouse` command to recreate the clearinghouse there. Make sure you specify the same clearinghouse name that was used at the source location.

To use the `create dns server clearinghouse` command, you must have the NET \$MANAGE rights identifier.

Example

In the following example, the database files for clearinghouse `.chicago2_ch` were successfully copied (relocated) to the default file location on server `.orion`. The following `create dns server clearinghouse` command (issued on server `.orion`) creates a new clearinghouse named `.chicago2_ch` on that server:

```
dns> create dns server clearinghouse .chicago2_ch
```

After the `.chicago2_ch` clearinghouse is successfully created on server `.orion`, enter the following `enable dns server clearinghouse` command (also at server `.orion`) to enable the new clearinghouse:

```
dns> enable dns server clearinghouse .chicago2_ch
```

9.6. Deleting a Clearinghouse

You may eventually need to delete a clearinghouse from the server system on which it resides when:

- The system is scheduled for reallocation or removal from your network.
- You no longer want or need the system to function as a DECdns server.
- You have relocated the clearinghouse on another server system and need to delete the clearinghouse from its original location.

Before You Delete a Clearinghouse

Before you delete a clearinghouse, consider the following restrictions:

- Make sure you have write and delete access to the clearinghouse you intend to delete and to its clearinghouse object entry. If any read-only replicas exist in the clearinghouse, you also

need control access to the directories of which those replicas are members so that DECdns can automatically delete them and rebuild the replica sets of the directories.

- Make sure the clearinghouse you intend to delete does not store a master replica of any directory. DECdns does not allow you to delete a clearinghouse that contains a directory's master replica. Before you can delete such a clearinghouse, you must designate another replica in that directory's replica set as the master replica by using the DECdns Control Program `set directory to new epoch` command. If no other replicas of the directory exist, you must create a read-only replica at another clearinghouse and then designate it as the directory's new master replica before you can delete the original master replica from the clearinghouse. See Section 9.2 for information on how to modify a replica's replica type.
- Although the `delete dns server clearinghouse` command automatically deletes any read-only replicas, VSI recommends that you delete each replica on the clearinghouse to be deleted. In this way, should the clearinghouse deletion fail, none of these unwanted replicas are left available for data requests. Be sure to leave one replica closest to the root, as required by the clearinghouse rules explained in Appendix B.

Note

Use the DECdns Control Program `delete replica at clearinghouse` command to delete replicas. Do not exclude replicas (using the `exclude` qualifier with the `set directory to new epoch` command).

To Delete a Clearinghouse

To delete a clearinghouse, first disable it, using the `disable dns clearinghouse` command. Then use the `delete dns server clearinghouse` command. Use both of these commands locally.

To use these commands, you must have the NET\$MANAGE rights identifier.

As part of the `delete dns server clearinghouse` command, DECdns automatically deletes all read-only replicas from the clearinghouse and rebuilds the replica sets of those directories, excluding the deleted replicas from their replica sets. In addition to deleting the clearinghouse, the command deletes the clearinghouse's associated clearinghouse object entry. The command may not delete the clearinghouse database files from the system. You should ensure that they are deleted, as indicated below.

Clearinghouse deletion can take some time to complete. DECdns deletes a clearinghouse only after successfully completing a skulk of the directory that stores its associated clearinghouse object entry. Because a clearinghouse's deletion may not be made known immediately to all replicas of the directory in which its clearinghouse object entry is stored, a deleted clearinghouse may appear to exist in the namespace for some time after you issue the command. You can initiate a skulk on the directory yourself to ensure that all replicas are updated as quickly as possible.

Example

The following commands disable and delete the clearinghouse `.paris2_ch` on your local server system.

```
dns>disable dns server clearinghouse .paris2_ch
dns> delete dns server clearinghouse .paris2_ch
```

After You Delete a Clearinghouse

Verify that the following clearinghouse database files have been deleted from their default location on the system (to ensure that they are not detected by the server during subsequent server restarts):

- `clearinghouse-name.checkpointnnnnnnnnnn`
- `clearinghouse-name.tlognnnnnnnnnn`
- `clearinghouse-name.version`

where `nnnnnnnnnn` represents an 10-digit number.

They reside, by default, in the `SYS$SYSDEVICE:[DNS$SERVER]` account. (If the clearinghouse was created with DNS Version 1 software and later converted to DECdns Version 2 format, the clearinghouse files reside, by default, in the `SYS$SYSROOT:[DNS$SERVER]` account.)

When you delete a clearinghouse, DECdns removes the contents of the `dns_files.txt` file (created when the clearinghouse is created and containing the path to the clearinghouse). This file is located in `SYS$SPECIFIC:[SYSMGR]`. Unless you have another clearinghouse on this server, delete the `dns_files.txt` file to complete cleanup of all clearinghouse-related files. If you have another clearinghouse on the server, keep this file and ensure that it includes a pointer to the remaining clearinghouse only. (The pointer to the deleted clearinghouse should be removed from the file.)

Chapter 10. Using the DECdns Configuration Program

Use the DECdns configuration program to perform the following tasks. Section 10.1 explains how to run the DECdns configuration program.

- Changing a clerk's default namespace (Section 10.2)
- Establishing communications with an off-LAN server (Section 10.3)
- Configuring a DECdns server in an existing namespace (Section 10.4)
- Converting an existing DNS Version 1 clearinghouse to DECdns Version 2 format (Section 10.4.4)
- Displaying address information for your local node (Section 10.5)

Section 10.6 explains how to create a new namespace using the `net$configure` procedure.

10.1. Running the DECdns Configuration Program

To invoke the DECdns configuration program, enter the following command:

```
$ @sys$manager:dns$configure.com
```

The following menu is displayed:

```
DECdns Configuration

[1] Set the default namespace
[2] Establish communications with an off-LAN server
[3] Configure server in an existing namespace
[4] Show address information of this node
[5] Exit
```

At anytime, you can enter ? for help or ^Z to quit the current operation

Pick a number from the list:

Table 10.1 describes the tasks you can perform with each of these menu options.

Table 10.1. Summary of DECdns Configuration Menu Options

Option	Task
1	Set the default namespace.
2	Establish an initial connection from this clerk to a server that exists outside the clerk's LAN. (DECdns server advertisement messages do not span WAN links.)
3	Configure a DECdns server (and its clearinghouse) in an existing namespace. Create an additional clearinghouse on an existing server. Convert an existing DNS Version 1 clearinghouse to DECdns Version 2 format.

Option	Task
4	Display the network service access point (NSAP) address information for the local node. Use this option on server nodes to provide address information needed by the configuration program on clerks to make an initial connection to the server across a WAN link.
5	Exit the DECdns configuration program and return to the system prompt.

10.2. Changing a Clerk's Default Namespace

To change a clerk's default namespace, follow these steps:

1. Choose option 1 ("Set the default namespace") from the configuration menu. The configuration program displays the nickname and namespace creation timestamp (NSCTS) of your current default namespace:

```
Your default namespace nickname is IAF
```

```
Your default namespace NSCTS is 00-12-34-56-77-A0-A1-A2-A3-A4-A5-A6-A7-B0
```

```
Do you want to change the default namespace?
```

2. If you do not want to change your default namespace, enter `no` to quit the procedure and return to the configuration menu.

If you want to change your default namespace, enter `yes`. If you respond `yes`, the configuration program displays a list of the nicknames for all the clerk's known namespaces:

```
Getting server data, please wait ...
```

```
[ 1] IAF
[ 2] NAF
[ 3] DOMAIN
[ 4] LOCAL
[ 5] X500
```

```
[ 0] - Reject this list -
```

```
Pick a number from the list: 2
```

This list contains all known namespaces for this clerk, including all the namespaces being advertised by servers on the clerk's own local area network (LAN) as well as off-LAN namespaces made known to the clerk through the use of configuration menu option 2 ("Establish communications with an off-LAN server"). This list also includes three special namespace nicknames that are already known to DECdns: `DOMAIN`, `LOCAL`, and `X500`. Do not select any of these here. You can select the `DOMAIN` and `LOCAL` namespace nicknames during the DECnet-Plus configuration procedure (`NET$CONFIGURE`).

3. Enter the number corresponding to the nickname of the namespace that you want to be your default. After you make a selection, the configuration program displays the nickname and NSCTS of your new default namespace and informs you that the clerk's startup script has been amended so that the clerk uses the new default namespace whenever it is enabled:

```
sys$manager:net$dns_clerk_startup.ncl changed to use the new default namespace.
```



```
Your default namespace nickname is NAF.  
Your default namespace NSCTS is AA-00-04-00-DE-11-A0-AA-F9-6E-56-  
DE-8E-00.
```

If the namespace you want to designate as the clerk's default namespace exists outside the clerk's LAN, its nickname may not appear on the list. In this case, enter 0 to reject the list and return to the main menu. Then choose option 2 ("Establish communications with an off-LAN server"). See Section 10.3 for complete instructions on how to make an initial connection to an off-LAN namespace; then, choose option 1 ("Set the default namespace").

10.3. Establishing Communications with an Off-LAN Server

A clerk learns about all namespaces on its own LAN by listening to advertisements from servers on the same LAN. Because server advertisements do not span wide area network (WAN) links, a clerk cannot automatically learn about namespaces that exist outside the clerk's own LAN. For a clerk to make an initial connection to an off-LAN server, you must provide the clerk with the server's network service access point (NSAP) address, DECnet Phase IV-compatible address, or IP address. This information is saved in the clerk's cache and is used to make subsequent connections to the off-LAN server.

To establish an initial connection to a server in an off-LAN namespace, follow these steps:

1. Contact the namespace administrator of the off-LAN namespace and obtain the DECnet Phase IV-compatible address (if one exists), the NSAP address, or the IP address of some server in that namespace. The system administrator of the off-LAN server can provide the NSAP or DECnet Phase IV-compatible address by using the DECdns configuration program on that system and choosing menu option 4 ("Show address information of this node").

Note

If the off-LAN server is a VAX Distributed Name Service (DNS) Version 1 server on an OpenVMS VAX system, you must have read access to the `SYS$LIBRARY:DNS$NS_DEF_FILE.DAT` file on that server. Otherwise, the configuration will fail.

2. Invoke the DECdns configuration program. See Section 10.1.
3. Choose option 2 ("Establish communications with an off-LAN server") from the configuration menu. The configuration program prompts you for the address information of a server in the off-LAN namespace. You can enter an NSAP address (as shown), a Phase IV-compatible address, or an IP address:

```
Enter NSAP or Phase IV compatible address or IP address of the server  
you want to connect to: %x490004aa0004066a1121
```

After you enter an address, the configuration program displays a list of the namespaces (known to the remote server) that were added to your clerk's list of known namespaces. This information is retained in the clerk's cache and will survive a reboot of the clerk system. For example:

```
Getting server data, please wait ...
```

```
These namespaces have been added to your clerk's list of known  
namespaces
```

[1] EMV

10.4. Configuring a DECdns Server in an Existing Namespace

You can use option 3 on the DECdns configuration menu ("Configure server in an existing namespace") to complete the following tasks:

- Configure a DECdns Version 2 server in an existing namespace (Sections 10.4.1 and 10.4.2).
- Create an additional clearinghouse on an existing server (Section 10.4.3).
- Convert an existing DNS Version 1 clearinghouse to DECdns Version 2 format (Section 10.4.4).

The first DECdns Version 2 server in a new namespace is usually configured as a result of (or following the process of) configuring DECnet-Plus software. Even if you maintain a small namespace that services only a few nodes, you should consider configuring at least one additional server on another stable system whose connectivity to your network is reliable. By maintaining your namespace on two servers (two clearinghouses), you create a real-time backup of namespace data and ensure that a failure on one of the servers will not interrupt DECdns service. As your namespace and network expand, you may want to configure additional servers to distribute namespace information around the network.

10.4.1. Before You Configure a Server

Before you configure a system as a DECdns server, perform the following tasks:

1. The most important step is planning how the namespace will be distributed across this and the existing DECdns servers. Will all directories exist in each clearinghouse, or will you distribute them across two or more clearinghouses? To keep this procedure simple, we assume you are configuring the second server and clearinghouse in the namespace, and it will contain a read-only copy of all directories found in the first (already existing) clearinghouse.
2. Determine the following information. In the examples given here, the information is obtained from the SYSTEM account on the node with the first clearinghouse.

- What is the first DECdns server node's full name? For example:

```
$ show log sys$node_fullname
"SYS$NODE_FULLNAME" = "WATTS_NS:.DNA_NODE.SHANTI::" (LNM
$SYSTEM_TABLE)
```

- On which node do you want to place the second clearinghouse? For example:

```
$ show log sys$node_fullname
"SYS$NODE_FULLNAME" = "WATTS_NS:.DNA_NODE.META::" (LNM
$SYSTEM_TABLE)
```

- What is the name of the existing clearinghouse? For example:

```
$ mcr dns$control
DNS> dir clear .*
          DIRECTORY
          CLEARINGHOUSE WATTS_NS:. *
          AT 08-APR-2019:10:38:24
```

shanti_ch

- What directories are located in the namespace? Check the root directory first for child pointers, then check all directories under the root for child pointers, as in the following example:

```
$ mcr dns$control
DNS> dir dir .*
          DIRECTORY
          DIRECTORY WATTS_NS:.*
                AT 08-APR-2019:10:41:41
DNA_BackTranslation
DNA_NODE
DNA_NodeSynonym
DTSS_GlobalTimeServers

DNS> dir dir .*...
          DIRECTORY
          DIRECTORY WATTS_NS:.DNA_BackTranslation.*
                AT 08-APR-2019:10:46:32
%X49
          DIRECTORY
          DIRECTORY WATTS_NS:.DNA_BackTranslation.%X49.*
                AT 08-APR-2019:10:46:33
%X0028
%X0037
          DIRECTORY
          DIRECTORY WATTS_NS:.DNA_BackTranslation.%X49.%X0028.*
                AT 08-APR-2019:10:46:53 ❶
          DIRECTORY
          DIRECTORY WATTS_NS:.DNA_BackTranslation.%X49.%X0037.*
                AT 08-APR-2019:10:46:53 ❶
          DIRECTORY
          DIRECTORY WATTS_NS:.DNA_NODE.*
                AT 08-APR-2019:10:47:03 ❶
          DIRECTORY
          DIRECTORY WATTS_NS:.DNA_NodeSynonym.*
                AT 08-APR-2019:10:47:03 ❶
          DIRECTORY
          DIRECTORY WATTS_NS:.DTSS_GlobalTimeServers.*
                AT 08-APR-2019:10:47:04 ❶
```

- ❶ No output means no subdirectories were found here.

Note

The WATTS_NS: example namespace is actually populated with .DNA_BackTranslation.%X49.* directories for DECnet Phase IV areas 1 through 63, (hexadecimal %X0001 through %X003F). To keep the output reasonably brief, only areas 40 and 55 (hexadecimal %X0028 and %X0037) are shown.

3. Verify that the DECdns server software and a valid server software license are installed on the system. See Section 10.4.1.1.
 4. Choose a name for the new clearinghouse. See Appendix A.
-

If you plan to name the clearinghouse in a directory other than the root directory, first verify that the directory allows the storage of clearinghouse object entries. See Section 12.8.2.

5. Ensure that the new server has a node object registered in the namespace to be joined. For example, use the following DECdns Control Program command:

```
dnscp show obj ns:.newsrv
```

6. Ensure that the node object has the correct addressing information. For example, use the following DECdns Control Program command:

```
dnscp show obj .newsrv dna$towers
```

The output should match output of the `ncl show address` command.

7. Ensure that the DECdns server storing the master replica of the directory to be joined is registered in the namespace and has correct addressing information. Each system should be able to connect to the other (for example, check using the `set host` command).
8. Grant required access to the directory in which you intend to name the new clearinghouse (usually the namespace's root directory) on behalf of the `DNS$Server` principal and the `system` account principal of the new server. See Section 10.4.1.2.

Configuring a DECdns Version 2 Server into a DNS Version 1 Namespace

Before you can configure a DECdns Version 2 server into an existing namespace that was created with DNS Version 1 software, you must prepare the namespace for use by DECnet-Plus. To accomplish this, you need to configure a DECdns Version 2 clerk into the DNS Version 1 namespace and create and populate a backtranslation directory (`.DNA_BackTranslation`) and node synonym directory (`.DNA_Node_Synonym`) in the root directory. You must create these directories to ensure that the DECdns Version 2 clerks and servers you later create are able to interpret and process the DNS Version 1-style access control entries that are already in use in the DNS Version 1 namespace. See the appropriate DECnet-Plus installation and configuration documentation for complete information on how to prepare a DNS Version 1 namespace for use by DECnet-Plus systems. Appendix F summarizes interoperability considerations in an environment with both DNS Version 1 and DECdns Version 2.

10.4.1.1. Verifying DECdns Server Software and License Requirements

Before you can configure a system as a DECdns server, you should verify that the following conditions are satisfied:

- **DECdns server software must be installed on the system.**

The DECdns server software is included as optional software on the DECnet-Plus installation media. Most system managers install the server software as part of the DECnet-Plus installation. Others may choose to postpone the server software installation until they need to configure the system as a DECdns server.

If DECdns server software has not been installed on the system, the following message is displayed when you choose option 3 on the DECdns configuration menu ("Configure server in an existing namespace") to configure the server.

The DECdns server software is not installed on this system. If you want to configure a server on the system, type N or ^Z to exit this procedure and install the server software before continuing.

After this message is displayed, you are returned to the main configuration menu.

If the DECdns server software was not installed during the initial DECnet-Plus installation, rerun the DECnet-Plus installation procedure to install the the optional DECdns server software before you try to configure the system as a DECdns server. See the appropriate DECnet-Plus installation documentation for information on how to install the DECdns server software.

- **A valid server software license must exist on the system.**

Before the DECdns configuration program permits you to configure a system as a DECdns server, it verifies that a valid DNS Version 1 or DECdns Version 2 server license exists in the license management database on the system. If a valid license cannot be found, the following message is displayed when you choose option 3 on the DECdns configuration menu ("Configure server in an existing namespace") to configure the server.

```
No DECdns server license is present.  If you want to install a server on
this system, type N or ^Z to exit this procedure and install a license
before continuing.
```

If you purchased but never installed a DECdns Version 2 server software license, invoke the License Management Facility (LMF) and install the license before you try to configure the system as a DECdns server. See the LMF documentation for complete information on how to install a DECdns server license. (If the system is currently configured as a DNS Version 1 server or, if you are creating an additional clearinghouse on an existing DECdns Version 2 server, a valid server license should already exist on the system.)

Note

If neither the DECdns server software nor a license can be found on the system, the following message is displayed.

```
The DECdns server software is not installed on this system. If you want to
configure a server on the system, type N or ^Z to exit this procedure and
install the server software and a valid license before continuing.
```

10.4.1.2. Granting the Access Required for Clearinghouse Creation

To successfully create a clearinghouse and perform subsequent clearinghouse operations, the DNS\$Server principal and the system account principal on the server system that you intend to configure must have sufficient access to the directory (usually the root) in which you intend to name the new clearinghouse. You must grant this access before you configure the server.

Before you configure a server, make sure you grant the following access rights:

- For the DNS\$Server principal on the server, grant read, write, delete, and control access to the directory in which you intend to name the new clearinghouse. Specify the principal as *nodename*.dns\$server, where *nodename* is the DECdns full name of the node on which the server is running.

- For the `system` account of the node, grant control access to the directory in which you intend to name the new clearinghouse. Specify the principal as `nodename.system`

You must enter the `add directory access` commands to grant this access from an account that has control access to the directory in which you intend to name the clearinghouse.

Example

The following two example commands grant the required access for the `DNS$Server` and `system` principals to the root directory of the namespace in which a new clearinghouse on node `.dna_node.meta` will be created: Note that if any replica of the directory in which you intend to name the new clearinghouse is stored on a VAX Distributed Name Service (DNS) Version 1 server (on a DECnet Phase IV node), additional access is required. See the section called “Additional Access Required for Interoperation with DNS Version 1 Servers” for more information.

1. The following command (entered from an account that has control access to the root directory) grants read, write, delete, and control access to the root directory (`.`) for the `DNS$Server` principal on node `.dna_node.meta`.

```
dns> add directory . access .dna_node.meta.dns$server for r,w,d,c
```

2. The following command (entered from an account that has control access to the root directory) grants read, write, delete, and control access to the root directory for the `system` account on node `.dna_node.meta`.

```
dns> add directory . access .dna_node.meta.system for r,w,d,c
```

Additional Access Required for Interoperation with DNS Version 1 Servers

If any replica of the directory in which you intend to name the new clearinghouse is stored on a VAX Distributed Name Service (DNS) Version 1 server (on a DECnet Phase IV node), you must create two additional access control entries (ACEs) that grant the same access described in the preceding example commands but contain Version 1 principals (in the format `nodename::username`). Assuming, from the preceding example, that a replica of the root directory is stored on a Version 1 server, you must enter the following two `add access` commands (from an account with control access to the root directory) to create the required Version 1-style ACEs:

```
dns> add directory . access dna_node.meta::dns$server for r,w,d,c
dns> add directory . access dna_node.meta::system for c
```

Appendix F summarizes interoperability considerations in an environment with both DNS Version 1 and DECdns Version 2.

10.4.2. Configuring the Server

To configure the server and create a clearinghouse, follow the steps listed below.

You can examine `SYS$SYSTEM:DNS$SERVER.LOG` for clearinghouse creation failures.

1. Choose option 3 ("Configure server in an existing namespace") from the configuration menu. The configuration program displays the nickname and NSCTS of this node's default namespace, and prompts you to enter the DECdns full name of the new clearinghouse that you are about to create on this server. Note that short-form names (local names) are not allowed.

```
Your default namespace nickname is WATTS_NS
```

Your default namespace NSCTS is 00-12-34-56-77-A0-A1-A2-A3-A4-A5-A6-A7-B0

Enter a name for the clearinghouse that will be created on this node. If you want to join a namespace other than your default namespace, include the namespace nickname as part of the full name. If the namespace nickname is ambiguous, use the NSCTS instead of the nickname. You must have appropriate access to the DECdns directory in which this clearinghouse will reside. See DECdns Management for more information.

Enter full name of new clearinghouse (include leading dot): `.Meta_CH`

2. After you enter a clearinghouse name, the configuration program prompts you to enter the name of the directory that you want be the clearinghouse's initial replica. Unless you specify otherwise at the prompt, DECdns creates by default a replica of the directory in which you named the new clearinghouse (see step 1) and stores the replica in the clearinghouse as its initial replica. This directory is displayed as the default response to the prompt. For example, because the clearinghouse name `.Meta_CH` was entered in step 1 of this sample procedure, the root directory `[.]` is shown as the default response in this step.

Enter the name of the directory that is to be stored in the clearinghouse as the initial replica. The directory name must be closer to the root (have fewer simple names) than the clearinghouse name. The default is the parent directory of the clearinghouse.

Enter replica full name (include leading dot) `[.]`:

If you named the clearinghouse in the root directory (such as `.Meta_CH` as shown in step 1), you must press Return to accept the default response of root directory `[.]`.

If you named the new clearinghouse in a directory other than the root directory, you can press Return to accept the parent directory of the directory that you specified in step 1 as the initial replica, or enter the name of another directory.

If you specify an initial replica directory other than the parent directory of the clearinghouse name (the default), you must set the `DNS$InCHName` attribute for that directory to `true` (even if you do not intend to store clearinghouse object entries in it). This attribute defines whether the directory or its descendants can store clearinghouse names. Use the DECdns Control Program `set directory` command to set this attribute.

3. After you specify the name of the new clearinghouse's initial replica, the configuration program prompts you to select the directory version for *all* directories that you will later create in this clearinghouse. If you intend to create only DNS Version 1 directories, set the directory version value to `V1.0.0`. Set the value to `V2.0.0` to create only DECdns Version 2 directories. Whether you set the value to `V1.0.0` or `V2.0.0`, you can still store both Version 1 and Version 2 directories in the clearinghouse. However, if you set the value to `V2.0.0`, you cannot replicate the directories you create in this clearinghouse in any Version 1 clearinghouse. Because a setting of `V1.0.0` allows you to create directories and replicate them in both Version 1 and Version 2 clearinghouses, the default response to the prompt is `V1.0.0` (option 1).

Enter the directory version for the clearinghouse. This affects all replicas stored in this clearinghouse. If you plan to replicate any of the directories created at this clearinghouse into a V1 clearinghouse, you must choose `V1.0.0`. Otherwise, choose `V2.0.0`.

```
[1] V1.0.0
[2] V2.0.0
```

Pick a number from the list [1]:

To create only Version 1 directories, press Return to accept the default response, option 1. To create only Version 2 directories, choose option 2.

After you make your selection, the configuration program creates the server and clearinghouse, displays an informational message, then returns you to the main configuration menu. The following message is displayed:

```
Server created. Clearinghouse files are in sys$sysdevice:[dns$server].
```

If the clearinghouse creation fails, double check that the required access (as described in Section 10.4.1.2) exists on the directory in which you are trying to name the new clearinghouse. If the access is correct, see Section 12.8 for more information on handling clearinghouse creation failures.

If any problem occurs at this step, verify that the new clearinghouse exists by using the DECdns Control Program command shown in the following example:

```
$ mcr dns$control
DNS> dir clear meta_ch
    DIRECTORY
        CLEARINGHOUSE  WATTS_NS:.meta_ch
        AT 08-APR-2019:10:38:24
meta_ch
```

4. Finally, replicate any directories from existing servers into the new clearinghouse, as explained in Section 7.2. You can designate any of these replicas to be master replicas by modifying the replica set, as explained in Section 9.2.

This step may require a large number of commands. VSI recommends that you create a command file similar to the one in Section G.2 of Appendix G to complete the process.

10.4.3. Creating an Additional Clearinghouse on an Existing Server

Although the DECdns configuration program supports the creation of multiple clearinghouses on one server, VSI does not recommend permanently locating two or more clearinghouses on the same server. A server cannot load-balance incoming clerk requests to multiple clearinghouses. Also, multiple clearinghouses demand more than a proportionate increase of system resources when compared to an individual clearinghouse and will compromise the performance of the one server on that system. As a rule, you should create a second clearinghouse on a server only when another dedicated server system is not available, or to temporarily relocate a functional clearinghouse when the server system on which the clearinghouse usually resides is being removed from your network.

If you must create an additional clearinghouse on an existing server, follow the procedure described in Sections 10.4.1 through 10.4.2. Be sure to choose a different name for the new clearinghouse than the name of the clearinghouse that is already operating on the server system.

10.4.4. Converting an Existing DNS Version 1 Clearinghouse to DECdns Version 2 Format

If you are already using a namespace (created with Version 1 of the VAX Distributed Name Service (DNS) software running on DECnet Phase IV), you may want to convert one or more of your existing DNS Version 1 clearinghouses to DECdns Version 2 format. By doing so, you can take advantage of the improved performance offered by DECdns Version 2. You can also continue to use your existing namespace rather than abandoning it and create a new namespace when you upgrade your networking software to DECnet-Plus for OpenVMS.

You convert a clearinghouse as part of the server configuration process performed by option 3 ("Configure server in an existing namespace") on the DECdns configuration menu.

Note

Before you try to convert a DNS Version 1 clearinghouse to DECdns Version 2 format, make sure the namespace served by the Version 1 clearinghouse has been prepared for use by DECnet-Plus. A backtranslation directory (`.DNA_BackTranslation`) and node synonym directory (`.DNA_Node_Synonym`), containing the node names of all nodes participating in the Version 1 namespace, must exist in the root directory. This is necessary to ensure that the DECdns Version 2 servers you later create can interpret and process the DNS Version 1-style access control entries that are already in use in the DNS Version 1 namespace. If these directories do not exist, be sure to create and populate them *before* you attempt to convert any DNS Version 1 clearinghouses to DECdns Version 2 format. See the appropriate DECnet-Plus installation and configuration documentation for complete information on how to configure the first DECdns Version 2 clerk into an existing DNS Version 1 namespace. See the appropriate DECnet-Plus network management documentation for information on how to create and populate the node synonym and backtranslation directories.

To convert a DNS Version 1 clearinghouse to DECdns Version 2 format, follow these steps:

1. Log in to the server node that stores the DNS Version 1 clearinghouse you want to convert to DECdns Version 2 format. Use the DNS Version 1 control program (DNS\$CONTROL) `add access` command to grant the following access on behalf of the `system` account:
 - Grant read, write, delete, test, and control access to the DNS Version 1 clearinghouse you intend to convert. Specify the principal of this ACE in DNS Version 1-style format (`nodename::system`).
 - Grant read, write, delete, test, and control access to the directory in which the clearinghouse is named. Specify the principal of this ACE in DNS Version 1-style format (`nodename::system`).
 - Grant read, write, delete, test, and control access to the DNS Version 1 clearinghouse you intend to convert. Specify the principal of this ACE with the DECnet Phase V full name (`.dna_node.nodename.system`).
 - Grant read, write, delete, test, and control access to the directory in which the clearinghouse is named. Specify the principal of this ACE with the full DECnet Phase V name (`.dna_node.nodename.system`).

For example, if you intend to convert a clearinghouse named `.eng.London_ch` that resides on a Phase-IV node named `true`, enter the following four commands:

```
dns> add access true::system clearinghouse .eng.London_ch /
rights=(r,w,d,t,c)

dns> add access true::system directory .eng /rights=(r,w,d,t,c)
```

```
dns> add access .dna_node.true.system clearinghouse .eng.London_ch -
_> /rights=(r,w,d,t,c)

dns> add access .dna_node.true.system directory .eng
/rights=(r,w,d,t,c)
```

You need to grant these access rights to ensure that the `system` account on the server has sufficient access to the clearinghouse you want to convert, and to the directory in which the clearinghouse is named (`.eng` in this example).

Note

As a precaution, before you proceed to the next step, VSI recommends that you create a replica of each directory stored in the Version 1 clearinghouse you intend to convert. In the event the clearinghouse conversion fails, these directories will remain available.

2. While logged in to the server node that stores the DNS Version 1 clearinghouse you want to convert, perform the following steps:
 - a. Install DECnet-Plus for OpenVMS software on the node and configure it as a DECdns Version 2 clerk in the namespace served by the DNS Version 1 server that you want to convert. See *VSI DECnet-Plus for OpenVMS Installation and Configuration* or *DECnet-Plus for OpenVMS Applications Installation and Advanced Configuration Guide* for complete information on how to configure a DECdns clerk.

- b. On the clerk system, at the OpenVMS system prompt, enter the following command to invoke the DECdns configuration program:

```
$ @ sys$manager:dns$configure.com
```

- c. Choose menu option 3 ("Configure server in an existing namespace"). When the configuration program detects the presence of the Version 1 clearinghouse, the following message is displayed:

```
You must convert your version 1 DECdns data so that you can use it
with version 2 DECdns. If you have already converted your data,
press Return.
```

```
DNS Version 1 clearinghouse(s) database exists on this system. Do you
want to convert the Version 1 data to DECdns Version 2 format [n]:
```

- d. Enter `Y` to convert the DNS Version 1 clearinghouse.

Before the DECdns configuration program initiates the conversion process, it verifies that the following server system parameters are satisfied:

- Available free page count is 2.5 times that of the Version 1 clearinghouse database you intend to convert.
- User quota `pgflquo` is set to permit the use of 2.5 times that of the Version 1 clearinghouse database.
- `SYSGEN` parameter `virtualpagcnt` is set high enough to allow the database conversion process to allocate 2.5 times that of the Version 1 clearinghouse database.

If any of these system criteria are not satisfied, the DECdns configuration program displays a warning message to inform you about which parameters need to be reset and to what degree. (See Section 10.4.5 for examples of these warning messages.) The clearinghouse conversion may complete successfully with less than the recommended memory. In the event that the conversion cannot complete, processing stops. If this occurs, you should reset any parameters for which you received a warning message before you retry the conversion.

In addition to these parameter recommendations, the DECdns configuration program requires that the available disk space on the server system is equal to the size of the DNS Version 1 clearinghouse database you intend to convert. If this requirement is not satisfied, the conversion process fails and the DECdns configuration program displays an informational message specifying the number of free blocks required to successfully perform the clearinghouse conversion. See Section 10.4.5 for an example of this informational message.

If the available disk space requirement is satisfied, no informational message is displayed, and the conversion process continues as shown in the following example output:

```
Conversion proceeding - please wait.
```

```
Beginning to convert clearinghouse TRW0306_NS:.trw0306_ch
  Elapsed=0 00:00:23.33  CPU=0:00:10.81  DIRs done=44%  MEM
  Kbytes=501
  Elapsed=0 00:00:44.12  CPU=0:00:27.01  DIRs done=86%  MEM
  Kbytes=1004
```

```
Successfully converted clearinghouse TRW0306_NS:.trw0306_ch
```

```
Clearinghouse database conversion completed successfully.
After backing up the following version 1 server data files, please
delete:
```

```
  SYS$SYSTEM:DNS$GLOBAL.GBL
  SYS$SYSROOT:[DNS$SERVER]trw0306_ch.DNS,.GBL
  Elapsed=0 00:00:59.27  CPU=0:00:32.59  DIRs done=100%  MEM
  Kbytes=1004
```

```
Type Return to continue:
```

- e. Press Return at the prompt to initiate the server creation process.

```
Server creation proceeding - please wait.
```

```
%RUN-S-PROC_ID, identification of created process is 0000005A
%PURGE-I-NOFILPURG, no files purged
%PURGE-I-NOFILPURG, no files purged
Create Node 0 DNS Server
  at 2019-03-24-15:16:48.424-05:00I0.629

Enable Node 0 DNS Server
  at 2019-03-24-15:17:00.301-05:00I0.513
```

When the server creation completes, the configuration program displays the following message and then returns you to the main configuration menu.

```
Server created and enabled successfully.
```

3. Exit the DECdns configuration program; then, from the system prompt, invoke the `decnet_register` utility. Choose menu option 2 to re-register the newly converted server node as a DECnet-Plus node. For complete information on how to use the `decnet_register` node registration tool, see *VSI DECnet-Plus for OpenVMS Network Management Guide*.

10.4.5. Clearinghouse Conversion Warnings and Informational Messages

OpenVMS Paging Recommendations

If the recommended Free Page Count, Page File Quota, or Virtual Page Count parameter requirements on the system are not satisfied, one or more of the following warning messages is displayed as shown in the following sample output:

```
Warning>> You may need your page file quota to be 10327 during conversion.
```

```
Warning>> You may require up to 10327 contiguous free pages during conversion.
```

```
>> This may mean that you need to add an additional pagefile.
```

```
Warning>> You may need to increase your VIRTUALPAGECNT to 10327 to complete conversion.
```

```
Warning>> You may need your page file quota to be 10327 during conversion.
```

If any of these warnings is displayed, the clearinghouse conversion may still succeed. However, VSI recommends that you stop the conversion process and reset the appropriate system/process parameters before you continue. See your OpenVMS system management documentation for complete information on how to reset these parameters.

Free Disk Space Requirement

If the available disk space on the server system is insufficient to accommodate the conversion operation, an error message, similar to the following example, is displayed and you are returned to the DECdns configuration menu.

```
ERROR>> Insufficient disk space on DKA100: disk;  
>> you need 4131 free blocks there for the conversion.  
>> Please make disk space available before continuing.
```

```
Elapsed=0 00:00:10.75 CPU=0:00:02.47 DIRs done= 0% MEM Kbytes=13
```

```
%DNS-F-CONVERT Cannot convert V1 data
```

Before you again attempt to convert the clearinghouse, you must increase the available disk space on the system to the number of free blocks specified in the message.

10.4.6. Reconfiguring a DECdns Server

If you want to reconfigure an existing server to have a new namespace, the reconfiguration process does not replace or delete the DECdns files used by the existing server. You must delete these files before the proper namespace pointers can take effect. For more information, see Section 6.7.2.

10.5. Displaying Address Information for Your Local Node

If your node is a server, system managers of clerks that want to participate in your server's namespace, but exist across WAN links, may contact you to obtain your server node's NSAP address. Clerks need this information to make an initial connection to your server.

To display the NSAP address information for your local node, choose option 4 ("Show address information of this node") from the DECdns configuration menu. The configuration program lists this information as shown in the following sample display:

```
This node's NSAP is %x490004aa0004066a1120
This node's NSAP is %x490004aa0004066a1121
```

The display will contain one or more NSAP addresses, each address corresponding to one of the protocols that the server runs (TP4, NSP, and so on). If more than one NSAP is listed, make sure you inform the manager of the clerk system of all addresses. At least one address is likely to correspond to a protocol that the clerk can use to make its initial connection to your server. See *VSI DECnet-Plus for OpenVMS Network Management Guide* for more information on NSAP addressing.

10.6. Creating and Initializing a New Namespace

You only need to create a new DECdns namespace if you are configuring the first DECdns server for the network (where no DECdns namespace exists) or if you are creating an additional namespace. When you create a namespace, you need a namespace nickname and clearinghouse name. The namespace nickname is part of the full name of every system configured subsequently in the network and should be unique to your network. The namespace nickname that you specify becomes the actual name of the namespace.

Note

DECnet-Plus does not support the creation of more than one namespace on a single DECdns server system. If you need more than one namespace in your network, you must initially create each namespace on its own DECdns server system.

You create and initialize a namespace during the DECnet-Plus advanced configuration procedure. See *DECnet-Plus for OpenVMS Applications Installation and Advanced Configuration Guide* for details.

Before creating and initializing a new namespace, first configure the server to use the Local namespace, then check that the DECnet software works properly.

To create a new namespace while configuring a DECnet-Plus system:

- The DECdns server software must be installed on the system.
- DECdns must be specified as one of the naming services configured on the system.

In addition, VSI highly recommends you to refer to the *VSI DECnet-Plus Planning Guide*. Once you understand what is involved in creating a namespace, you can configure the server node to use the new DECdns namespace and create and initialize that namespace.

Use the DECnet-Plus configuration procedure (`SYS$MANAGER:NET$CONFIGURE.COM`) and select option 2 ("Change Naming Information") to create a new namespace. Choose the DECdns directory service as the primary directory service to be used on the system. The configuration procedure then

prompts you for other information required for creating a namespace and the initial namespace directories.

The procedure instructs you to use the `dechnet_register` tool to:

- Create a command file to automatically register previously defined Phase IV nodes. Execute this command file before using the `dechnet_register` tool to manually register any other nodes.
- Create any directories needed for node names that should be registered immediately, according to your namespace design. (This includes the node on which you are currently running if the node is not in the root directory of the new namespace or if the configuration procedure indicates it was not able to register the node automatically.)
- Add backtranslation directories for any non-Phase-IV areas/IDPs. Failure to do so will lead to backtranslation failures. Once you have added the necessary backtranslation directories, you may need to use the `ncl flush session control naming cache entry "*" command`.
- Change the local node's registered name from its default name to its final full name. (The local node is registered as a Phase IV node with a default name when you execute the Phase IV node registration command file mentioned above.)
- Change the currently registered names of other nodes from their default names to their final full names when appropriate (for example, when they are upgraded to run DECnet-Plus software).
- Continue to use the `dechnet_register` tool to:
 - Create any additional directories you need for node names, as new nodes are brought up on the network.
 - Register new nodes as they are brought up on the network.
 - Add members to the `new_ns:.DNA_Registrar` access control group (where `new_ns` is the new namespace name).
- Use the DECdns Control Program to:
 - Add specific access control to individual directories, objects, and soft links.
 - Create replicas of directories (see Section 7.2).

For more information about the `dechnet_register` tool, see the *VSI DECnet-Plus for OpenVMS Network Management Guide*.

Chapter 11. DECdns Control Program Command Dictionary

This chapter describes the DECdns Control Program (DNSCP) commands. The DECdns Control Program is an interface you can use to manage the components of DECdns and the contents of the namespace.

Table 11.1 lists the DNSCP commands grouped by entity.

Table 11.1. DECdns Control Program Commands

Entity	Command	Function
Child	Create	Creates a child pointer
	Delete	Deletes a child pointer
	Directory	Displays a list of child pointers
	Show	Displays a child pointer's attribute information
Clearinghouse	Add Access	Adds an access control entry to a clearinghouse's access control set
	Directory	Displays a list of clearinghouses
	Remove Access	Deletes an access control entry from a clearinghouse's access control set
	Show	Displays a clearinghouse's DNSCP attribute information
Directory	Show Access	Displays a clearinghouse's access control set
	Add Access	Adds an access control entry to a directory's access control set
	Create	Creates a directory
	Delete	Deletes a directory
	Directory	Displays a list of directories
	Recreate	Creates a copy of a directory with a new full name
	Remove Access	Deletes an access control entry from a directory's access control set
	Set	Modifies directory characteristics
	Set to New Epoch	Modifies a directory's replica set
	Set to Skulk	Initiates a skulk
	Show	Displays a directory's attribute information
Show Access	Displays a directory's access control set	
DNS Clerk	Create	Creates a clerk
	Delete	Deletes a clerk
	Disable	Stops operation of the clerk
	Dump	Dumps the clerk cache
	Enable	Starts the clerk

Entity	Command	Function
	Set	Modifies clerk characteristics
	Show	Displays a clerk's attribute information
DNS Clerk Known Namespace	Create	Adds a namespace to the list of namespaces in a clerk's cache
	Delete	Removes a namespace from the list of namespaces in the clerk's cache
	Set	Modifies a known namespace name attribute
	Show	Displays a namespace's attribute information
DNS Clerk Manual Name Server	Create	Creates knowledge in the clerk's cache about a server that exists across the wide area network (WAN)
	Delete	Deletes knowledge from the clerk's cache about a server that exists across the WAN
	Show	Displays knowledge in the clerk's cache about a server that exists across the WAN
DNS Clerk Remote Clearinghouse	Show	Displays a remote clearinghouse's attribute information
DNS Server	Create	Creates a server
	Delete	Deletes a server
	Disable	Stops operation of the server
	Enable	Starts the server
	Initialize	Creates a new namespace and the first server in the namespace
	Show	Displays a server's attribute information
DNS Server Clearinghouse	Clear	Removes knowledge of a clearinghouse from a server
	Create	Creates a clearinghouse
	Delete	Deletes a clearinghouse
	Disable	Stops operation of a clearinghouse
	Enable	Starts a clearinghouse
	Show	Displays a clearinghouse's Network Control Language (NCL) attribute information
Group	Add Access	Adds an access control entry to a group's access control set
	Add Member	Adds a member to an existing group
	Create	Creates a group
	Delete	Deletes a group
	Directory	Displays a list of groups
	Remove Access	Deletes an access control entry from a group's access control set
	Remove Member	Deletes a member from an existing group
	Set	Modifies group characteristics

Entity	Command	Function
	Show	Displays a group's attribute information
	Show Access	Displays a group's access control set
Link	Add Access	Adds an access control entry to a soft link's access control set
	Create	Creates a soft link
	Delete	Deletes a soft link
	Directory	Displays a list of soft links
	Recreate	Creates a copy of a soft link with a new full name
	Remove Access	Deletes an access control entry from a soft link's access control set
	Replace	Replaces a soft link to redirect lookups
	Set	Modifies a soft link's characteristics
	Show	Displays a soft link's attribute information
	Show Access	Displays a soft link's access control set
Object	Add	Adds a value to an object's modifiable, set-valued attribute\
	Add Access	Adds an access control entry to an object entry's access control set
	Create	Creates a new object entry
	Delete	Deletes an object entry
	Directory	Displays a list of object entries
	Recreate	Creates a copy of an object entry with a new full name
	Remove	Deletes a value from an object's application-defined, set-valued attribute
	Remove Access	Deletes an access control entry from an object entry's access control set
	Replace	Replaces an object entry with a soft link
	Set	Changes the value of an object's modifiable, single-valued attribute
	Show	Displays an object entry's attribute information
	Show Access	Displays an object entry's access control set
Replica	Create	Adds a replica of an existing directory to a clearinghouse
	Delete	Removes a replica of a directory from a clearinghouse
	Show	Displays a replica's attribute information
Subtree	Change Access	Changes a principal in a subtree's access control entries
	Change Group Member	Changes a group member in all access control groups containing that member in a subtree
	Delete	Deletes a subtree and its contents
	Dump	Dumps a subtree and its contents into an interim file

Entity	Command	Function
	Merge	Dumps a directory and then merges its contents into an existing subtree
	Merge File	Merges the contents of a file into an existing subtree
	Remove Access	Removes a principal from the access control set of a particular directory and its contents
	Remove Group Member	Removes a member from all groups in a subtree
	Replace	Replaces a subtree with soft links pointing to the new subtree location

add clearinghouse access

add clearinghouse access — Adds an access control entry (ACE) to a clearinghouse's access control set (ACS).

Format

```
add clearinghouse access clearinghouse-name access principal [as group] [for] access
```

Arguments

clearinghouse-name

The name of the clearinghouse to which access is being added.

principal

The principal for whom access is being added. You can specify a principal as a group name, a collection of principals denoted with wildcards (for example, `.org.name*`), or an individual name in the format `nodename.username`. To specify a DNS Version 1-style principal, use the format `nodename::username`. The phrase `as group` indicates the specified principal is a group. You cannot use this phrase with wildcard principal names.

access

The access rights for the specified principal. Rights are read, write, delete, test, control, and none, and you can specify them as `r`, `w`, `d`, `t`, `c`, and `non`. Separate multiple access rights with commas.

Description

This command adds an access control entry to a clearinghouse's access control set. Access rights are defined as follows:

Read	The principal can look up the clearinghouse by name and read any attribute of the clearinghouse.
Write	The principal can change the replica type of any replica stored in the clearinghouse, create or delete replicas in the clearinghouse, alter any modifiable attribute of the clearinghouse (except the ACS).

Delete	The principal can delete the clearinghouse.
Test	The principal can check the value of any attribute of the clearinghouse.
Control	The principal can alter the clearinghouse's ACS and move the clearinghouse to another server.
None	The principal has no access rights.

For more information on defining and modifying access control, refer to Chapter 5.

Access Rights

You must have control access to the clearinghouse whose access control set (ACS) is being modified.

Example

The following command grants an access control group named `.testgroup` read, write, test, and control access to the `.paris2_ch` clearinghouse.

```
dns> add clearinghouse .paris2_ch access .testgroup -
_> as group for r, w, t, c
```

add directory access

add directory access — Adds an access control entry (ACE) to a directory's access control set (ACS).

Format

```
add directory access directory-name [access-option] access principal [as group] [for]
access
```

Arguments

directory-name

The full name of the directory.

access-option

The extent to which the access rights apply. Possible access options are `default` and `nopropagate`. Enter one or both of them. If you enter both options, separate them with a comma. If you omit this argument, the ACE applies to the directory and automatically propagates to subsequent child directories.

<code>default</code>	Indicates that the ACE applies to all new object entries created in this directory. Access to already existing entries is not affected. A default ACE applies only to the contents of the directory, not to the directory itself. If you do not use the default option, the ACE applies to the directory.
<code>nopropagate</code>	Prevents the access rights in this ACE from being inherited by subsequently created child directories of the specified directory. When used in conjunction with <code>default</code> , prevents the ACS from being inherited by the contents of future children of the specified directory. <code>Nopropagate</code> is optional; if you do not use it, access rights propagate automatically.

principal

The principal for whom access is being added. You can specify a principal as a group name, a collection of principals denoted with wildcards (for example, `.org.name*`), or an individual name in the format `nodename.username`. To specify a DNS Version 1-style principal, use the format `nodename::username`. The phrase `as group` indicates the specified principal is a group. You cannot use this phrase with wildcard principal names.

access

The access rights for the specified principal. Rights are read, write, delete, test, control, and none, and you can specify them as `r`, `w`, `d`, `t`, `c`, and `non`. Separate multiple access rights with commas.

Description

This command adds an ACE to a directory's access control set. Access rights are defined as follows:

Read	The specified principal can look up the directory by name, list the contents of the directory, and read any directory attribute.
Write	The specified principal can create object entries or soft links in the directory, skulk the directory, and create, modify, or delete child directories.
Delete	The specified principal can delete the directory or any name in the directory.
Test	The specified principal can check the value of any attribute of the directory.
Control	The specified principal can perform any operation on any object entry, soft link, or child in the directory, as well as read or modify any attribute of the directory (including its ACS), and modify the replica type of a replica or the epoch value of the directory.
None	Does not grant the specified principal any access rights.

For more information on defining and modifying access control, refer to Chapter 5.

Access Rights

You must have control access to the directory whose ACS is being modified. You also need write access to the clearinghouse.

Example

The following command grants read and write access for the `.DNS_Admin` administration group to the `.sales` directory.

```
dns> add directory .sales access .DNS_Admin as group for r,w
```

add group access

`add group access` — Adds an access control entry (ACE) to a group's access control set (ACS).

Format

```
add group group-name access principal [as group] [for] access
```

Arguments

group-name

The full name of the group.

principal

The principal for whom access is being added as a member of the group. You can specify a principal as a group name, a collection of principals denoted with wildcards (for example, `.org.name*`), or an individual name in the format `nodename.username`. To specify a DNS Version 1-style principal, use the format `nodename::username`. The phrase `as group` indicates the specified principal is a group. You cannot use this phrase with wildcard principal names.

access

The access rights for the specified principal. Rights are read, write, delete, test, control, and none, and you can specify them as `r`, `w`, `d`, `t`, `c`, and `non`. Separate multiple access rights with commas.

Description

This command adds an access control entry to a group's access control set. Access rights are defined as follows:

Read	The principal can look up the group by name and read any attribute of the group.
Write	The principal can change any modifiable group attribute except the ACS.
Delete	The principal can remove the member from the set of group members
Test	The principal can check the value of any attribute of the group.
Control	The principal can alter the group's ACS.
None	The principal does not have access rights.

For more information on defining and modifying access control, refer to Chapter 5.

Access Rights

You must have control access to the group whose ACS is being modified.

Example

The following command grants user `.sales.deneb.smith` read access to the `.DNS_admin` group.

```
dns> add group .DNS_admin access .sales.deneb.smith for r
```

add group member

`add group member` — Adds a member to an existing group.

Format

```
add group group-name member [=] principal [as group]
```

Arguments

group-name

The full name of the group.

principal

The principal that is being added as a member of the group. You can specify a principal as a group name, a collection of principals denoted with wildcards (for example, `.org.name*`), or an individual name in the format, `nodename.username`. To specify a DNS Version 1-style principal, use the format `nodename::username`. The phrase `as group` indicates the specified principal is itself a group. You cannot use this phrase with wildcard principal names.

Description

This command adds a member to an existing group.

Access Rights

You must have write access to the group to which you are adding a member.

Example

The following command adds the member `smith` on node `.sales.orion` to the `admin` group.

```
dns> add group .admin member .sales.orion.smith
```

add link access

`add link access` — Adds an access control entry (ACE) to a soft link's access control set (ACS).

Format

```
add link link-name access principal [as group] [for] access
```

Arguments

link-name

The full name of the soft link.

principal

The principal for whom access is being added. You can specify a principal as a group name, a collection of principals denoted with wildcards (for example, `.org.name*`), or an individual name in the format, `nodename.username`. To specify a DNS Version 1-style principal, use the format `nodename::username`. The phrase `as group` indicates the specified principal is a group. You cannot use this phrase with wildcard principal names.

access

The access rights for the specified principal. Rights are `read`, `write`, `delete`, `test`, `control`, and `none`, and you can specify them as `r`, `w`, `d`, `t`, `c`, and `non`. Separate multiple access rights with commas.

Description

This command adds an access control entry to a soft link's access control set. Access rights are defined as follows:

Read	The principal can look up the soft link by name, read any soft link attribute, and perform wildcard lookups.
Write	The principal can change any modifiable attribute except the ACS.
Delete	The principal can delete the soft link.
Test	The principal can check the value of any attribute of the soft link.
Control	The principal can alter the soft link's ACS.
None	The principal does not have access rights.

For more information on defining and modifying access control, refer to Chapter 5.

Access Rights

You must have control access to the soft link whose ACS is being modified.

Example

The following command grants an access control group named `.testgroup` read, write, and test access to the soft link `.sales.asia`.

```
dns> add link .sales.asia access .testgroup as group for r, w, t
```

add object

`add object` — Adds a value to a modifiable, set-valued attribute (including application-defined attributes) of an object entry.

Format

```
add object object-name attribute-name [=] attribute-value
```

Arguments

object-name

The full name of an object entry.

attribute-name

The name of a particular attribute. Specify your own attribute name or one of the DECdns-defined attributes. Separate multiple attributes with commas.

attribute-value

The value of a particular attribute. You can express the values of application-defined attributes as quoted strings, "ps"; hexadecimal strings, %x FF00EE; or concatenations of them in parentheses, (%x0103 "ps").

Description

This command adds a value to a modifiable, set-valued attribute, including application-defined attributes. If the value is already defined for the attribute, no error message is generated. Usually this task is performed through the client application, because the client application defines the name of the attribute and the syntax of its value.

Access Rights

You must have write access to the object entry or control access to the parent directory in which you intend to store the attribute.

Example

The following command adds the value "ps" to the user-defined set-valued attribute `printcap` of an object entry named `.sales.east.deskprinter`.

```
dns> add object .sales.east.deskprinter printcap "ps"
```

add object access

`add object access` — Adds an access control entry (ACE) to an object entry's access control set (ACS).

Format

```
add object object-name access principal [as group] [for] access
```

Arguments

object-name

The full name of the object entry.

principal

The principal for whom access is being added. You can specify a principal as a group name, a collection of principals denoted with wildcards (for example, `.org.name*`), or an individual name in the format, `nodename.username`. To specify a DNS Version 1-style principal, use the format `nodename::username`. The phrase `as group` indicates the specified principal is a group. You cannot use this phrase with wildcard principal names.

access

The access rights for the specified principal. Rights are read, write, delete, test, control, and none, and you can specify them as `r`, `w`, `d`, `t`, `c`, and `non`. Separate multiple access rights with commas.

Description

This command adds an access control entry to an object entry's access control set. Access rights are defined as follows:

Read	The principal can look up the object entry by name, read any object attribute, and perform wildcard lookups.
Write	The principal can change any modifiable attribute except the ACS.
Delete	The principal can delete the object entry.
Test	The principal can check the value of the object entry.
Control	The principal can alter the object entry's ACS.
None	The principal does not have access rights.

For more information on defining and modifying access control, refer to Chapter 5.

Access Rights

You must have control access to the object entry whose ACS is being modified.

Example

The following command grants read, write, and test access to user `smith` on node `.sales.orion` for an object entry named `.admin.work_disk3`.

```
dns> add object .admin.work_disk3 access .sales.orion.smith for r, w, t
```

change subtree access

`change subtree access` — Replaces an existing principal with a new principal in all ACEs associated with the subtree you specify.

Format

```
change subtree tree-name [...] access old-principal new-principal [exclude entry-type]
```

Arguments

tree-name

The name of the topmost directory in the subtree. When used without the optional recursion notation (`. . .`), the change applies only to the specified directory and the soft links and objects in that directory. The recursion notation causes the change to additionally apply to all child directories and their contents.

old-principal

The principal that you want to change. You can specify a principal as a group name or an individual name in the format `nodename.username`. To specify a DNS Version 1-style principal, use the format `nodename::username`.

new-principal

The new principal. You can specify a principal as a group name or an individual name in the format `nodename.username`. To specify a DNS Version 1-style principal, use the format `nodename::username`.

entry-type

One or more of the following arguments to exclude from principal modification: objects, links, or directories. Multiple directories can be excluded in a single command. Use any combination of the following *entry-type* specifiers, separating multiple arguments with commas:

```
objects  
links  
directory directory-name
```

Description

This command changes all relevant access control entries (ACEs) associated with the directory specified in *tree-name* and all relevant ACEs associated with that directory's contents. You can use the optional recursion notation (*. . .*) to modify the ACEs associated with all the child directories and their contents. You can also use the optional *exclude* argument to restrict the type of entries affected by this command.

Access Rights

You must have control and write access to the directory you specify as well as to the contents of the directory. If you use the command recursively, you also need control and write access to all child directories (and their contents) of the directory you specify.

Example

The following command changes the old principal *.pjl.smith* to the new principal *.ins.smith* in all ACEs associated with the *.admin* directory and its contents. By using the recursion notation (*. . .*), the command additionally changes the ACEs of all child directories and their contents.

```
dns> change subtree .admin... access .pjl.smith .ins.smith
```

change subtree group member

change subtree group member — Replaces an existing group member's principal specification with a new group member's principal specification in all access control groups named in the directory or subtree you specify.

Format

```
change subtree tree-name [...] group member old-member new-member [exclude directory  
directory-name]
```

Arguments

tree-name

The name of the topmost directory in the subtree. When used without the optional recursion notation, the change applies only to groups in the specified directory. The recursion notation causes the change to additionally apply to groups in all child directories.

old-member

The name of the existing group member that you want to replace.

new-member

The new name of the group member.

directory-name

One or more directories that contain groups you want to exclude from this change. You can exclude multiple directories with a single command. Separate multiple arguments with commas.

Description

This command replaces an existing group member's principal specification with a new group member's principal specification in all access control groups named in the directory or subtree you specify. You can use the optional recursion notation (. . .) to extend the command's effect to the groups contained in all child directories of that directory. If you use the command recursively, you can use the optional `exclude directory directory-name` argument to exclude groups named in a particular directory (and all its child directories) from group member modification. You can exclude multiple directories in a single command. Specify multiple directories in the following format:

```
exclude directory directory-name,directory-name,directory-name
directory-name
```

Access Rights

You must have control access to the group whose member you intend to change. If you use the command recursively, you must have control access to all groups affected by the command.

Example

The following command replaces the old member `.pjl.smith` with new member `.jmh.smith` in all groups in the `.admin` directory and its child directories.

```
dns> change subtree .admin... group member .pjl.smith .jmh.smith
```

clear dns server clearinghouse

`clear dns server clearinghouse` — Removes knowledge of the specified clearinghouse from the server's memory.

Format

```
clear [node node-id] dns server clearinghouse clearinghouse-name
```

Arguments

node-id

The name of the node. If you do not specify a node name, the local node is assumed.

clearinghouse-name

The full name of the clearinghouse.

Description

This command removes the specified clearinghouse from the server's memory. This ensures that the clearinghouse is not auto-enabled on server restarts, even if the clearinghouse database files themselves are not deleted. This command is part of the process of relocating a clearinghouse. See Section 9.5 for more information. You can also enter this command through the NCL interface.

Privileges Required

You must have the NET\$MANAGE rights identifier.

Example

The following command removes knowledge of the `.paris2_ch` clearinghouse from the server's memory.

```
dns> clear dns server clearinghouse .paris2_ch
```

create child

`create child` — Creates a child pointer at the master replica of the parent directory.

Format

```
create child child-name clearinghouse clearinghouse-name
```

Arguments

child-name

The full name of the child pointer.

clearinghouse-name

The name of a clearinghouse that contains a replica of the child directory.

Description

This command creates a child pointer at the master replica of the parent directory. When DECdns looks up a name in the namespace, it uses child pointers to locate directory replicas. See Section 12.10 for complete information on how to restore a deleted child pointer.

Note

You should use the `create child` command only to re-create a child pointer that was accidentally deleted.

Access Rights

You must have read access to the orphaned child directory and write access to the parent directory of the orphaned child directory.

Example

The following command creates the child pointer for the `.sales.east` directory in the `.ny_ch` clearinghouse.

```
dns> create child .sales.east clearinghouse .ny_ch
```

create directory

`create directory` — Creates a directory.

Format

```
create directory directory-name [clearinghouse clearinghouse-name]
```

Arguments

directory-name

The full name of the directory.

clearinghouse-name

The name of the clearinghouse where the directory is created.

Description

This command creates a new directory with the name you specify. If no clearinghouse is specified, DECdns creates the master replica of the directory in the same clearinghouse as the parent directory's master replica. For more information on creating and managing directories, see Chapter 7.

Access Rights

You must have write access to the clearinghouse in which you are creating the new directory and write access to the parent of the new directory.

Example

The following command creates a new directory named `.region1` and stores it in a clearinghouse named `.eng_ch1` rather than in the same clearinghouse as the master replica of the parent directory.

```
dns> create directory .region1 clearinghouse .eng_ch1
```

create dns clerk

`create dns clerk` — Creates a clerk on the specified node.

Format

```
create [node node-id] dns clerk
```

Arguments

node-id

The name of the node. If you do not specify a node name, the local node is assumed.

Description

This command creates a clerk on the specified node. You can also enter this command through the NCL interface. This command should not normally be executed outside of the DECnet startup procedure. For more information on managing clerks, see Chapter 6.

Note

To create a clerk, enter the command `@SYS$STARTUP:DNS$CLERK_STARTUP` from the DCL prompt. You must have the NET\$MANAGE rights identifier to execute this command. You can only use the command locally; you must be logged in to the system where the clerk resides. See Section 6.7.3 for more information on how to create or restart a clerk.

Privileges Required

You must have the NET\$MANAGE rights identifier.

Example

The following command creates a clerk on node `.mfg.umbriel`.

```
dns> create node .mfg.umbriel dns clerk
```

create dns clerk known namespace

`create dns clerk known namespace` — Adds a namespace to the list of namespaces cached by a specified DECdns clerk.

Format

```
create [node node-id] dns clerk known namespace name NSCTS nscts
```

Arguments

node-id

The name of the node. If you do not specify a node name, the local node is assumed.

name

A simple name for the namespace.

nscts

The value of the namespace creation timestamp (NSCTS) that is automatically assigned when the namespace is created. The format of the NSCTS is 14 pairs of hexadecimal digits (*xx-xx*).

Description

This command adds a namespace to the list of namespaces cached by the DECdns clerk. This is useful for defining namespaces the clerk does not learn about automatically from advertisements on a local area network (LAN). The simple name you supply in the *name* argument becomes both name and nickname. If the name you supply conflicts with an existing name or nickname, this command is rejected. You can also enter this command through the NCL interface.

Privileges Required

You must have the NET\$MANAGE rights identifier.

Example

The following command adds the namespace with the name `jns` and NSCTS value of `08-00-2B-0D-C0-9D-CD-3B-C6-16-EC-3B-94-00` to the list of namespaces cached by the local clerk.

```
dns> create dns clerk known namespace jns NSCTS -  
_> 08-00-2B-0D-C0-9D-CD-3B-C6-16-EC-3B-94-00
```

create dns clerk manual nameserver

`create dns clerk manual nameserver` — Creates knowledge in the local clerk's cache about a server that exists across a wide area network (WAN).

Format

```
create [node node-id] dns clerk manual nameserver name tower TowerSet
```

Arguments

node-id

The name of the node on which the clerk exists. If you do not specify a node name, the local node is assumed.

name

A simple name for the manual name server. The name is used only as a handle for managing this entity.

TowerSet

The Network Architecture (NA) TowerSet address of the server node. (You must use a continuation character (-) for commands that extend beyond one line of text, but this only works if it is the very last character on the line of text.) The format of a TowerSet is:

```
{([DNA_OSInetwork , nsap-value ])}
```

Description

This command creates knowledge in the local clerk's cache about a server that exists across a WAN. It gives the clerk the information it needs to contact the server across a WAN and cache the other information that the clerk needs to communicate with that server. You can also enter this command through the NCL interface. You can use the DECdns configuration program to establish communications with a server across a WAN, as explained in Chapter 10.

Note

You should not normally enter this command from the DECdns Control Program (DNSCP). You can use the configuration program to accomplish what this command does.

Privileges Required

You must have the NET\$MANAGE rights identifier.

Example

The following command informs the clerk on node `.mfg.umbriel` about the existence of the server `nrl`.

```
dns> create node .mfg.umbriel dns clerk manual nameserver nrl tower -  
-> {[ DNA_OSInetwork , 49::00-04:AA-00-04-00-6A-11:20 ]}
```

create dns server

`create dns server` — Creates a server on the specified node.

Format

```
create [node node-id] dns server
```

Arguments

node-id

The name of the node. If you do not specify a node name, the local node is assumed.

Description

This command creates a server on the specified node. You can also enter this command through the NCL interface. This command should not normally be executed outside of the DECnet startup procedure.

Note

To create a clerk, enter the command `@SYS$STARTUP:DNS$SERVER_STARTUP` from the DCL prompt. You must have the NET\$MANAGE rights identifier to execute this command. You can only use the command locally; you must be logged in to the system where the clerk resides. See Section 6.7.3 for more information on how to create or restart a clerk.

Privileges Required

You must have the NET\$MANAGE rights identifier.

Example

The following command creates a DECdns server on the local node.

```
dns> create dns server
```

create dns server clearinghouse

`create dns server clearinghouse` — Creates a clearinghouse on the specified node.

Format

```
create [node node-id] dns server clearinghouse clearinghouse-name [new directory version version-number,] [initial replica replica-name,] [file filespec]
```

Arguments

node-id

The name of the node. If you do not specify a node name, the local node is assumed.

clearinghouse-name

The full name of the clearinghouse.

version-number

The DECdns version number the new directories will have at this clearinghouse. Specify the value as *Vx.y.z*, where *x* defines the major release number, *y* specifies the minor version number, and *z* specifies an ECO level. This argument is optional. Set the value to V1.0.0 if you intend to create DNS Version 1 directories. Set it to V2.0.0 to create only DECdns Version 2 directories. If you omit this argument, the default is V2.0.0.

replica-name

The full name of the first directory replica to store in the clearinghouse. This argument is optional. If you omit this argument, the parent directory of this clearinghouse becomes the initial replica.

filespec

A file specification that will contain the clearinghouse. This argument, which is optional, is useful if you have moved an existing clearinghouse and do not want new default names to be generated automatically. The default directory for the `dns$server` account.

Description

This command creates a clearinghouse on a specified node. You can specify the directory version, the initial replica to be stored in the clearinghouse, and the file name. This command is useful after moving a clearinghouse or if you have moved the clearinghouse file. You can also enter this command through the NCL interface.

Note

The `create dns server clearinghouse` command is normally executed only by the DECdns configuration program during the configuration of a DECdns server in an existing namespace (see Chapter 10). You should use this command only to re-create a clearinghouse whose database files are relocated on another server system.

Access Rights

The account executing the command needs write access to the directory in which you want to name the clearinghouse. This access must be propagated to all members of the directory's replica set before you enter the `create dns server clearinghouse` command. Otherwise, the command fails. If you do need to add write access for the directory, be sure to `skulk` the directory successfully before you try to create the clearinghouse. For more information about the access rights required for this command, see Section 12.8.1.

Privileges Required

You must have the NET\$MANAGE rights identifier.

Example

The following command creates a clearinghouse named `.sales.ny_ch` on node `.sales.orion`.

```
dns> create node .sales.orion dns server clearinghouse .sales.ny_ch
```

create group

`create group` — Creates a group.

Format

```
create group group-name
```

Arguments

group-name

The full name of the group.

Description

This command creates a group. For more information on managing groups, see Chapter 5.

Access Rights

You must have write access to the directory in which you intend to create the group.

Example

The following command creates a group named `.sales_group1` in the directory `.sales`.

```
dns> create group .sales.sales_group1
```

create link

create link — Creates a soft link and optionally specifies an expiration time and an extension time.

Format

```
create link link-name destination destination-name [expiration expiration-time] [extension extension-time]
```

Arguments

link-name

The full name of the soft link.

destination-name

The full name of the entry to which the soft link points.

expiration-time

A date and time after which DECdns checks for existence of the soft link's target and either extends or deletes the soft link. The value is specified as *yyyy-mm-dd-hh:mm:ss*. This argument is optional. If you omit the argument, the soft link is permanent and must be explicitly deleted.

extension-time

A period of time in which to renew the soft link's life if it expires but still points to an existing name. The value is specified as *ddd-hh:mm:ss*. This argument is optional. The default is 000-00:00:00.

Description

This command creates a soft link and optionally specifies an expiration time and an extension time. For more information on managing soft links, see Chapter 9.

Access Rights

You must have write access to the directory in which you intend to create the soft link.

Example

The following command creates a permanent soft link named `.sales.asia.price-server` that points to an object entry named `.sales.eur.price-server`.

```
dns> create link .sales.asia.price-server destination -  
_> .sales.eur.price-server
```

create object

create object — Creates a new object entry.

Format

`create object object-name DNS$Class class-name DNS$ClassVersion value`

Arguments

object-name

The full name of the object entry.

class-name

The class of object entry being created. You can specify an application-defined class name. A class is specified as a simple name limited to 31 characters.

value

The version of the class assigned to the object. Specify the value as *v.n*, where *v* defines the major release number and *n* specifies the minor version number. Specifying a class version is useful for allowing the definition of a class to evolve as an application is revised.

Description

This command creates a new object entry. This task is usually done through a client application.

Access Rights

You must have write access to the directory where you intend to store the object entry.

Example

The following command creates an object entry named `.sales.east.floor1cprn` with the DNS \$Class `printer` and DNS\$ClassVersion value `1.0`. The object entry describes a color printer on the first floor of the company's eastern sales office.

```
dns> create object .sales.east.floor1cprn DNS$Class printer -  
_> DNS$ClassVersion 1.0
```

create replica

`create replica` — Adds a replica of an existing directory to the specified clearinghouse.

Format

`create replica directory-name [at] clearinghouse clearinghouse-name`

Arguments

directory-name

The full name of the directory.

clearinghouse-name

The full name of the clearinghouse in which you want to create the replica.

Description

This command adds a replica of an existing directory to the specified clearinghouse. You are creating a read-only replica, which is a copy of the directory to which users cannot directly make changes. You can only modify a directory at the master replica. The skulking process automatically distributes any modifications made to the master replica to all read-only replicas in the directory's replica set. For more information on creating replicas, see Chapter 7. For information on modifying a replica set, see Chapter 9.

Access Rights

You must have read, write, delete, and control access to the directory you are replicating. You must also have write access to that directory's parent directory, and write access to the clearinghouse in which you are storing the replica.

The access required on the directory and parent directory must be propagated to all members of the directories' replica sets before you enter the `create replica` command. Otherwise, the command fails. If you need to add this access, be sure to skulk the directories successfully before you try to create the replica.

The `DNS$Server` principal (`nodename.dns$server`) and the system principal (`nodename.system`) on the server node where you intend to create the replica needs read, write, delete, and control access to the directory you intend to replicate and write access to its parent directory.

Example

The following command creates a replica of the `.mfg` directory in the clearinghouse `.parisl_ch`:

```
dns> create replica .mfg at clearinghouse .parisl_ch
```

delete child

`delete child` — Deletes a child pointer from the namespace.

Format

```
delete child child-name
```

Arguments

child-name

The full name of the child pointer.

Description

This command deletes a child pointer from the namespace.

Note

Use the `delete child` command only when the directory to which the child pointer refers was deleted and the child pointer accidentally remains.

Access Rights

You must have delete access to the directory in which the child pointer is stored.

Privileges Required

You must have system administrator's privileges.

Example

The following command deletes the child pointer that accidentally remained after the `.sales.east` directory was deleted:

```
dns> delete child .sales.east
Directory .sales is still reachable at clearinghouse iaf:.Parisl_ch.
```

delete directory

`delete directory` — Deletes a directory from the namespace.

Format

`delete directory` *directory-name*

Arguments

directory-name

The full name of the directory.

Description

This command deletes a directory from a namespace. The directory may not contain any object entries, soft links, or child pointers. The master replica must be the only remaining replica in the namespace. Use the `delete replica at clearinghouse` command if you need to remove read-only replicas. For more information on deleting directories, see Chapter 9.

Access Rights

You need write access to the clearinghouse that stores the master replica of the directory and delete access to the directory itself.

Example

The following command deletes the `.eng` directory.

```
dns> delete directory .eng
```

delete dns clerk

delete dns clerk — Deletes the DECdns clerk on the specified node.

Format

```
delete [node node-id] dns clerk
```

Arguments

node-id

The name of the node. If you do not specify a node name, the local node is assumed.

Description

This command deletes the DECdns clerk on the specified node and reclaims all clerk system resources. You must disable a clerk before you delete it (see the `disable dns clerk` command). You can also enter this command through the NCL interface. For more information on managing clerks, see Chapter 6.

Privileges Required

You must have the NET\$MANAGE rights identifier.

Example

The following command deletes a clerk running on node `.mfg.umbriel`.

```
dns> delete node .mfg.umbriel dns clerk
```

delete dns clerk known namespace

delete dns clerk known namespace — Removes a namespace from a specified clerk's list of known namespaces.

Format

```
delete [node node-id] dns clerk known namespace identifier
```

Arguments

node-id

The name of the node. If you do not specify a node name, the local node is assumed.

identifier

The identifier of the namespace. This is a required argument. You can use one of the following:

<i>name</i>	The name of the namespace. The <i>name</i> argument may be different from the nickname if the nickname is ambiguous.
<i>nscts</i>	The value of the namespace creation timestamp (NSCTS) assigned to the specified namespace when it was created. The format is 14 pairs of hexadecimal digits (<i>xx-xx</i>).

Description

This command deletes a namespace from the list of namespaces cached by the specified DECdns clerk. This command is useful if a namespace becomes obsolete, or if ambiguous namespace nicknames exist in the clerk's cache. You can also enter this command through the NCL interface.

Note

You are not permitted to delete the known namespace that is currently the default namespace (that is, the one shown by `show dns clerk default namespace`).

Privileges Required

You must have the NET\$MANAGE rights identifier.

Example

The following command removes the namespace with the name `jns` from the clerk's list of known namespaces.

```
dns> delete dns clerk known namespace jns
```

delete dns clerk manual nameserver

`delete dns clerk manual nameserver` — Removes the knowledge of a server that exists across a WAN from the local clerk's cache.

Format

```
delete [node node-id] dns clerk manual nameserver name
```

Arguments

node-id

The name of the node on which the clerk exists. If you do not specify a node name, the local node is assumed.

name

The simple name of the manual name server entity you want to delete.

Description

This command removes the knowledge of a server that exists across a WAN from the local clerk's cache. You can also enter this command through the NCL interface.

Privileges Required

You must have the NET\$MANAGE rights identifier.

Example

The following command removes knowledge of server `nrl` from the clerk cache on node `.mfg.umbriel`.

```
dns> delete node .mfg.umbriel dns clerk manual nameserver nrl
```

delete dns server

`delete dns server` — Deletes the DECdns server on the specified node.

Format

```
delete [node node-id] dns server
```

Arguments

node-id

The name of the node. If you do not specify a node name, the local node is assumed.

Description

This command deletes the DECdns server on the specified node and reclaims all server resources except clearinghouses, which remain. You must disable a server before you can delete it. You can also enter this command through the NCL interface. For more information on managing servers, see Chapter 6.

Privileges Required

You must have the NET\$MANAGE rights identifier.

Example

The following command deletes the DECdns server from node `.mfg.polaris`.

```
dns> delete node .mfg.polaris dns server
```

delete dns server clearinghouse

`delete dns server clearinghouse` — Deletes a clearinghouse on the specified node. You must disable a clearinghouse before you can delete it. You must disable and delete the clearinghouse from the local node only.

Format

```
delete dns server clearinghouse clearinghouse-name
```

Arguments

clearinghouse-name

The full name of the clearinghouse.

Description

This command deletes a clearinghouse from the specified node. You can also enter this command through the NCL interface. You must disable a clearinghouse before you can delete it. This command also automatically deletes all read-only replicas from the clearinghouse when executed. DECdns does not permit you to delete a clearinghouse that contains a master replica. See Chapter 9 for more information about handling master replicas when deleting a clearinghouse.

Note

Although deleting a clearinghouse automatically deletes the clearinghouse's replicas, VSI recommends that, before deleting the clearinghouse, you manually delete each read-only replica. In this way, should the clearinghouse deletion fail, none of these unwanted replicas are left available for data requests. Be sure *not* to delete the replica closest to the root, as required by the clearinghouse rules explained in Appendix B.

Access Rights

You must have delete access to the directories in the clearinghouse as well as to the clearinghouse.

Privileges Required

You must have the NET\$MANAGE rights identifier.

Example

The following command deletes a clearinghouse named `.sales.ny_ch`:

```
dns> delete dns server clearinghouse .sales.ny_ch
```

delete group

`delete group` — Deletes a group from the namespace.

Format

```
delete group group-name
```

Arguments

group-name

The full name of the group.

Description

This command deletes a group from the namespace. The group does not have to be empty to be deleted. For more information on managing groups, see Chapter 5.

Access Rights

You must have delete access to the group you are deleting.

Example

The following command deletes the group named `.sales_group1` from the `.sales` directory.

```
dns> delete group .sales.sales_group1
```

delete link

delete link — Deletes a soft link.

Format

```
delete link link-name
```

Arguments

link-name

The full name of the soft link.

Description

This command deletes a soft link. For more information on managing soft links, see Chapter 9.

Access Rights

You must have delete access to the soft link you want to delete.

Example

The following command deletes the soft link named `.sales.asia`.

```
dns> delete link .sales.asia
```

delete object

delete object — Deletes an object entry from the namespace.

Format

```
delete object object-name
```

Arguments

object-name

The full name of the object entry.

Description

This command deletes an object entry from the namespace. This task is usually done through the client application that created the object entry, except under specific circumstances (for example, if the application is obsolete or no longer has access to the namespace).

Access Rights

You must have delete access to the object entry that you want to delete.

Example

The following command deletes the object entry `.floor1pr2` from the directory `.sales.east`.

```
dns> delete object .sales.east.floor1pr2
```

delete replica

`delete replica` — Removes a replica of a directory from a clearinghouse.

Format

```
delete replica directory-name [at] clearinghouse clearinghouse-name
```

Arguments

directory-name

The full name of the directory.

clearinghouse-name

The full name of the clearinghouse.

Description

This command removes a replica of a directory from a clearinghouse. Use this command to delete read-only replicas. Use the `delete directory` command to delete the master replica and the entire directory. For more information on deleting replicas, see Chapter 7.

Access Rights

You must have control access to the directory whose replica you intend to delete, write access to the clearinghouse from which you are deleting the replica, and write and delete access to the directory's parent.

Example

The following command deletes a replica of the `.mfg` directory from the `.parisl_ch` clearinghouse.

```
dns> delete replica .mfg at clearinghouse .parisl_ch
```

delete subtree

`delete subtree` — Deletes a specified directory and its contents, or a hierarchy of directories and their contents.

Format

```
delete subtree tree-name [...] [exclude directory directory-name]
```

Arguments

tree-name

The name of the topmost directory in the subtree. The recursion notation causes the change to additionally apply to all child directories and their contents. When used without the optional recursion notation, the change applies only to the specified directory. This then behaves just like the `delete directory` command in that the directory must be empty to be deleted.

directory-name

The full name of a directory that you want to exclude from deletion. When you exclude a directory, its parent directory is preserved.

Description

This command deletes the specified directory and its contents, or a hierarchy of directories and their contents. Before using this command, you must delete all read-only replicas and all clearinghouse object entries in any of the affected directories. You can use the optional recursion notation (`. . .`) to additionally delete all child directories and their contents. The optional `exclude directory` argument lets you specify one or more directories to exclude from deletion. Specify multiple directories in the following format:

```
exclude directory directory-name, directory-name, directory-name  
directory-name
```

Access Rights

You must have read, write, and delete access to the directory you specify as well as the contents of the directory. If you use the command recursively, you also need read, write, and delete access to all child directories (and their contents) of the directory you specify.

Example

The following command deletes the `.pjl` directory and its contents as well as all of its child directories and their contents.

```
dns> delete subtree .pjl...
```

directory child

directory child — Displays a list of all the child pointers whose names match the specified child name.

Format

```
directory child child-name [prepositional-phrase]
```

Arguments

child-name

A specific child name or a complete directory specification followed by a wildcard template for matching simple names of child pointers.

prepositional-phrase

A phrase that affects the destination or content of command output. You can use one or more prepositional phrases. Be sure to precede each of the following prepositional phrases with a comma and a space:

with <i>attribute</i> [<i>relop</i>] <i>value</i>	When used with a wildcard <i>child-name</i> , limits the output only to directories whose specified attributes have certain values.
to file[= <i>filename</i>]	Redirects the output to <i>filename</i> . If the file does not exist, this command creates it. If the file does exist, its contents are overwritten.
to extend file[= <i>filename</i>]	Appends the output to an existing <i>filename</i> . If the file does not exist, it is created.
to terminal	Directs the output to the terminal. This is the default option.

Description

This command displays a list of all the child pointers whose names match the specified entity name.

Example

The following command displays all child pointers named in the `.paris` directory.

```
dns> directory child .paris.*
```

The following command displays all child pointers whose names begin with the string `.z` in the `.sales` directory:

```
dns> directory child .sales.z*
```

```

                                DIRECTORY
                                CHILD  NRL:.sales.z*
                                AT    17-APR-2019:16:32:02

zba
zeh
zpl
```

zsj

directory clearinghouse

directory clearinghouse — Displays a list of all the clearinghouses whose names match the specified clearinghouse name.

Format

directory clearinghouse *clearinghouse-name* [*prepositional-phrase*]

Arguments

clearinghouse-name

A specific clearinghouse full name or a complete directory specification followed by a wildcard template for matching simple names of clearinghouses.

prepositional-phrase

A phrase that affects the destination or content of command output. You can use one or more prepositional phrases. Be sure to precede each of the following prepositional phrases with a comma and a space:

with <i>attribute</i> [<i>relop</i>] <i>value</i>	When used with a wildcard <i>clearinghouse-name</i> , limits the output only to directories whose specified attributes have certain values.
to file[= <i>filename</i>]	Redirects the output to <i>filename</i> . If the file does not exist, this command creates it. If the file does exist, its contents are overwritten.
to extend file[= <i>filename</i>]	Appends the output to an existing <i>filename</i> . If the file does not exist, it is created.
to terminal	Directs the output to the terminal. This is the default option.

Description

This command displays a list of the clearinghouses whose names match the specified name.

Example

The following command displays all clearinghouses named in the root directory (.).

```
dns> directory clearinghouse .*
```

The following command displays all clearinghouses named in the .pjl directory.

```
dns> directory clearinghouse .pjl.*
```

```

                DIRECTORY
CLEARINGHOUSE  NRL:.pjl.*
                AT   17-APR-2019:16:35:01

```

```
ares_ch
athena_ch
mars_ch
```

directory directory

`directory directory` — Displays the names of all the directories whose names match the specified directory name.

Format

`directory directory` *directory-name* [*prepositional-phrase*]

Arguments

directory-name

A specific directory name or a complete directory specification followed by a wildcard template for matching simple names of directories.

prepositional-phrase

A phrase that affects the destination or content of command output. You can use one or more prepositional phrases. Be sure to precede each of the following prepositional phrases with a comma and a space:

<code>with attribute</code> [<i>relop</i>] <i>value</i>	When used with a wildcard <i>directory-name</i> , limits the output only to directories whose specified attributes have certain values.
<code>to file</code> [= <i>filename</i>]	Redirects the output to <i>filename</i> . If the file does not exist, this command creates it. If the file does exist, its contents are overwritten.
<code>to extend</code> <code>file</code> [= <i>filename</i>]	Appends the output to an existing <i>filename</i> . If the file does not exist, it is created.
<code>to terminal</code>	Directs the output to the terminal. This is the default option.

Description

This command displays the names of all the directories whose names match the specified directory name.

Example

The following command displays the names of all the directories whose names are stored in the directory `.sales`.

```
dns> directory directory .sales.*
```

The following command displays the names of all the directories whose names begin with the string `.ad*`.

```
dns> directory directory .ad*
```

```

                                DIRECTORY
                                DIRECTORY  NRL: .ad*
                                AT    17-APR-2019:16:40:02

adb
admin
adx
```

directory group

directory group — Displays a list of groups whose names match the specified group name.

Format

```
directory group group-name [prepositional-phrase]
```

Arguments

group-name

A specific group name or a complete directory specification followed by a wildcard template for matching simple names of groups.

prepositional-phrase

A phrase that affects the destination or content of command output. You can use one or more prepositional phrases. Be sure to precede each of the following prepositional phrases with a comma and a space:

<code>with attribute [<i>relop</i>] <i>value</i></code>	When used with a wildcard <i>group-name</i> , limits the output only to directories whose specified attributes have certain values.
<code>to file[=<i>filename</i>]</code>	Redirects the output to <i>filename</i> . If the file does not exist, this command creates it. If the file does exist, its contents are overwritten.
<code>to extend file[=<i>filename</i>]</code>	Appends the output to an existing <i>filename</i> . If the file does not exist, it is created.
<code>to terminal</code>	Directs the output to the terminal. This is the default option.

Description

This command displays a list of the groups whose names match the specified group name.

Example

The following command displays all the groups whose names are stored in the directory `.dist`.

```
dns> directory group .dist.*
```

The following command displays all the groups whose names begin with the string `.d`.

```
dns> directory group .d*
```

```

                                DIRECTORY
                                GROUP  NRL: .d*
                                AT    17-APR-2019:16:44:02
des_registrar
dis_dev
drx_servers
```

directory link

directory link — Displays a list of soft links whose names match the link name that you specify.

Format

```
directory link link-name [prepositional-phrase]
```

Arguments

link-name

A specific name of a soft link or a complete directory specification followed by a wildcard template for matching simple names of soft links.

prepositional-phrase

A phrase that affects the destination or content of command output. You can use one or more prepositional phrases. Be sure to precede each of the following prepositional phrases with a comma and a space:

<code>with attribute [<i>relop</i>] <i>value</i></code>	When used with a wildcard <i>link-name</i> , limits the output only to directories whose specified attributes have certain values.
<code>to file[=<i>filename</i>]</code>	Redirects the output to <i>filename</i> . If the file does not exist, this command creates it. If the file does exist, its contents are overwritten.
<code>to extend file[=<i>filename</i>]</code>	Appends the output to an existing <i>filename</i> . If the file does not exist, it is created.
<code>to terminal</code>	Directs the output to the terminal. This is the default option.

Description

This command displays the names of soft links whose names match the name that you specify.

Example

The following command displays all the soft links whose names begin with the `.admin.new.link1` string.

```
dns> directory link .admin.new.link1*
```

The following command displays all the soft links whose names begin with the string `.c*`.

```
dns> directory link .c*
```

```

          DIRECTORY
          SOFTLINK  NRL: .c*
                   AT  17-APR-2019:16:44:30
```

```
crx_conf
crx_notes
```

directory object

`directory object` — Displays a list of all the object entries (including groups and clearinghouse object entries) whose names match the object entry name that you specify.

Format

`directory object object-name [prepositional-phrase]`

Arguments

object-name

A specific object entry name or a complete directory specification followed by a wildcard template for matching simple names of object entries.

prepositional-phrase

A phrase that affects the destination or content of command output. You can use one or more prepositional phrases. Be sure to precede each of the following prepositional phrases with a comma and a space:

<code>with <i>attribute</i> [<i>relop</i>] <i>value</i></code>	When used with a wildcard <i>object-name</i> , limits the output only to directories whose specified attributes have certain values.
<code>to file[=<i>filename</i>]</code>	Redirects the output to <i>filename</i> . If the file does not exist, this command creates it. If the file does exist, its contents are overwritten.
<code>to extend file[=<i>filename</i>]</code>	Appends the output to an existing <i>filename</i> . If the file does not exist, it is created.
<code>to terminal</code>	Directs the output to the terminal. This is the default option.

Description

This command displays a list of all the object entries (including groups and clearinghouse object entries) whose names match the object name that you specify.

Example

The following command displays all the object entries in the directory `.eng`.

```
dns> directory object .eng.*
```

```

      DIRECTORY
      OBJECT  NRL: .eng.*
      AT     17-APR-2019:16:51:33
```

```
ny1_ch
ny1_admin
paris1_ch
perth1_ch
tokyo1_ch
tokyo1_sales
```

disable dns clerk

`disable dns clerk` — Stops the DECdns clerk on the specified node.

Format

```
disable [node node-id] dns clerk
```

Arguments

node-id

The name of the node. If you do not specify a node name, the local node is assumed.

Description

This command stops the DECdns clerk on the specified node, causing all active communication with any DECdns server to be aborted and all client calls in progress to fail with an error. You can also enter this command through the NCL interface. The clerk cache is copied to disk. When this procedure has completed, the clerk's `state` attribute is set to off. For more information on managing clerks, see Chapter 6.

Note

If you are disabling a clerk on a node where a server is running, make sure you disable the server first.

Privileges Required

You must have the NET\$MANAGE rights identifier.

Example

The following command stops the DECdns clerk running on node `.mfg.miranda`.

```
dns> disable node .mfg.miranda dns clerk
```

disable dns server

`disable dns server` — Stops the DECdns server on the specified node.

Format

```
disable [node node-id] dns server
```

Arguments

node-id

The name of the node. If you do not specify a node name, the local node is assumed.

Description

This command stops the DECdns server on the specified node. The server is disabled after all transactions in process have completed and an updated clearinghouse checkpoint file has been

written to disk. You can also enter this command through the NCL interface. When this procedure is completed, the server's `state` attribute is set to `off`.

Depending on the disk speed, memory, and the size of the database (in particular, the checkpoint file), the `disable dns server` command can take up to 30 minutes. For more information on managing servers, see Chapter 6.

Privileges Required

You must have the `NET$MANAGE` rights identifier.

Example

The following command stops the DECdns server running on the `.eng.abc` node.

```
dns> disable node .eng.abc dns server
```

disable dns server clearinghouse

`disable dns server clearinghouse` — Disables the specified clearinghouse. VSI recommends that you issue this command locally only.

Format

```
disable dns server clearinghouse clearinghouse-name
```

Arguments

clearinghouse-name

The name of the clearinghouse being disabled.

Description

This command disables the specified clearinghouse on the local node. When this procedure is completed, the clearinghouse's `state` attribute is set to `off`. You can also enter this command through the NCL interface. For more information on managing clearinghouses, see Chapter 6.

Privileges Required

You must have the `NET$MANAGE` rights identifier.

Example

The following command disables the `.ny_ch` clearinghouse on the local node:

```
dns> disable dns server clearinghouse .ny_ch
```

dump dns clerk cache

`dump dns clerk cache` — Dumps the clerk cache to the terminal for use in solving DECdns problems.

Format

```
dump dns clerk cache
```

Description

This command dumps the clerk cache to the terminal for use in solving DECdns problems. You can only dump a local clerk's cache.

Privileges Required

You must have CMKRNL privileges.

Example

The following command dumps the clerk cache running on the local node.

```
dns> dump dns clerk cache
```

dump subtree

dump subtree — Dumps a subtree into an interim file.

Format

```
dump subtree tree-name [...] into file filename [exclude entry-type]
```

Arguments

tree-name

The name of the topmost directory in the subtree. When used without the optional recursion notation, the dump applies only to the specified directory and its contents. The recursion notation causes the command to additionally dump all child directories and their contents.

filename

The name of the interim file to which the subtree is dumped.

entry-type

One or more of the following types of entries to exclude from the dump: objects, links, or specific directories. Multiple directories can be excluded in a single command. Use any combination of the following *entry-type* specifiers, separating multiple arguments with commas:

```
objects  
links  
directory directory-name
```

Description

This command dumps a directory and its contents into an interim file. Use the optional recursion flag (. . .) to additionally dump all child directories and their contents. Use the optional `exclude`

argument to omit links, objects, or specific directories from the dump file. Use the file name extension `.dat` as a convention for interim file names. This command is useful for backing up a directory or as the first step of the merging directories procedure. See Section 9.4 for more information about merging directories.

Access Rights

You must have read access to the specified directory and its contents. If you use the command recursively, you also need read access to all child directories (and their contents) of the directory you specify.

Example

The following command creates an interim file named `pjl.dat` that contains the `.pjl` directory and its contents.

```
dns> dump subtree .pjl into file pjl.dat
```

enable dns clerk

`enable dns clerk` — Starts the DECdns clerk on the specified node.

Format

```
enable [node node-id] dns clerk
```

Arguments

node-id

The name of the node. If you do not specify a node name, the local node is assumed.

Description

This command starts the DECdns clerk on the specified node. You can also enter this command through the NCL interface. When this procedure is complete, the clerk's `state` attribute is set to `on`. For more information on managing clerks, see Chapter 6.

Privileges Required

You must have the `NET$MANAGE` rights identifier.

Example

The following command starts the DECdns clerk on the local node.

```
dns> enable dns clerk
```

enable dns server

`enable dns server` — Starts the DECdns server on the specified node.

Format

`enable [node node-id] dns server`

Arguments

node-id

The name of the node. If you do not specify a node name, the local node is assumed.

Description

This command starts the DECdns server on the specified node. You can also enter this command through the NCL interface. All clearinghouses on the server are automatically enabled when this command is issued. When this procedure is completed, the server's `state` attribute is set to `on`.

Depending on the disk speed, memory, and the size and state of the database (in particular, the checkpoint file), the `enable dns server` command can take several minutes. If the previous server shutdown was not completed correctly (for example, the system crashed during the process), this command can take up to 30 minutes. For more information on managing servers, see Chapter 6.

Privileges Required

You must have the NET\$MANAGE rights identifier.

Example

The following command starts the local DECdns server.

```
dns> enable dns server
```

enable dns server clearinghouse

`enable dns server clearinghouse` — Enables the specified clearinghouse on the specified node.

Format

`enable [node node-id] dns server clearinghouse clearinghouse-name`

Arguments

node-id

The name of the node. If you do not specify a node name, the local node is assumed.

clearinghouse-name

The name of the clearinghouse being enabled. There is no default.

Description

This command enables the specified clearinghouse on the specified node. When this procedure is complete, the clearinghouse's `state` attribute is set to `on`. Because the `enable dns server`

command auto-enables clearinghouses known to a server, this command is only necessary when a clearinghouse has specifically been disabled (see the `disable dns server clearinghouse` command). You can also enter this command through the NCL interface. For more information on managing clearinghouses, see Chapter 6.

Privileges Required

You must have the NET\$MANAGE rights identifier.

Example

The following command enables the `.ny_ch` clearinghouse on the local node.

```
dns> enable dns server clearinghouse .ny_ch
```

initialize dns server

`initialize dns server` — Creates a new namespace, assigns it the specified nickname, creates a clearinghouse, and places the master replica of the root directory in that clearinghouse.

Format

```
initialize [node node-id] dns server nickname namespace-nickname, owner name, root  
clearinghouse clearinghouse-name
```

Arguments

node-id

The name of the node. If you do not specify a node name, the local node is assumed.

namespace-nickname

The nickname of the namespace. You must specify the name; there is no default name.

name

The simple name of a user or account to be given initial access to the entities created with this command. Based on the name that you must supply, the software generates ACEs that grant the user or account read, write, delete, test, and control access to the first clearinghouse in the namespace and to the root directory. The principal name in the ACEs is derived by attaching the full name of the node where the command is executed to the front of the simple name that you supply.

clearinghouse-name

The simple name of the first clearinghouse in the namespace. You must specify the name; there is no default name.

Description

This command creates a new namespace, assigns it the specified nickname, creates a clearinghouse, and places the master replica of the root directory in that clearinghouse. Initial access to the

clearinghouse and root directory is given to the specified user, who can then define an access control policy. You can also enter this command through the NCL interface.

Note

This command should ordinarily be executed only by the DECnet configuration procedure. This operation can only be performed once in the lifetime of a namespace. For details on creating and initializing a namespace, see Section 10.6.

Privileges Required

You must have the NET\$MANAGE rights identifier.

Example

The following command creates a namespace, assigns it the nickname `jns`, gives all access rights to the `root` account, and creates the clearinghouse `paris_ch`, placing the master replica of the root directory in that clearinghouse.

```
dns> initialize dns server nickname jns, owner root, -  
_> root clearinghouse paris_ch
```

merge file

`merge file` — Merges the contents of an interim file that was created with the `dump subtree` command into an existing subtree.

Format

```
merge file file ifile into subtree tree-name [failures to file [=] filename]
```

Arguments

`ifile`

The name of an interim file that contains a directory and its contents, or a hierarchy of directories and their contents.

`tree-name`

The name of the topmost directory in the subtree.

`filename`

The name of a file that contains names that could not be merged.

Description

This command merges the contents of an interim file that was created using the `dump subtree` command into an existing subtree whose top directory is specified in `tree-name`. If the target `tree-name` does not exist, the command returns an error and the user must use the `create directory` command to create it. The `failures to file = filename` argument specifies a file name

to contain the names that could not be merged. For more information on merging directories, see Chapter 9.

Access Rights

You must have control and write access to the directory you specify as well as the contents of the directory.

Example

The following command merges the interim file `branch1.dat` with the `.pjl` directory.

```
dns> merge file branch1.dat into subtree .pjl
```

merge subtree

`merge subtree` — Dumps a directory or subtree and its contents into an interim file and then merges the contents of that file into an existing subtree.

Format

```
merge subtree old-tree-name [...] [into] subtree new-tree-name [exclude entry-type]
```

Arguments

old-tree-name

The name of the topmost directory in the subtree that is being changed. When used without the optional recursion notation (...), only the specified directory and its contents are merged. The recursion notation additionally causes all child directories (and their contents) to merge into the target subtree.

new-tree-name

The name of the topmost directory in the target subtree.

entry-type

One or more of the following types of entries to exclude from the change: objects, links, or directories. Multiple directories can be excluded in a single command. Use any combination of the following *entry-type* specifiers, separating multiple arguments with commas:

```
objects  
links  
directory directory-name
```

Description

This command dumps a subtree into an interim file and then merges the contents of that file into an existing subtree. Use the recursion flag (. . .) to merge an entire subtree and its contents. If you do not use the recursion flag, only the specified directory and its contents are dumped and merged into the target subtree.

This command is useful when all clearinghouses are available for every directory in both subtrees and when no duplicate names exist in source and target directories. If a duplicate name is detected, or if any affected clearinghouse cannot be reached while the `merge subtree` command is in progress, the command completes what it can. In this situation, a named interim file or failures file with a randomly generated name is created in the current directory. The directory *new-tree-name* must already exist. If it does not, the command returns an error and you must use the `create directory` or `recreate directory` command to create it.

Access Rights

You must have control and write access to the directory you specify as well as the contents of the directory. If you use the command recursively, you also need control and write access to all child directories (and their contents) of the directory you specify.

Example

The following command merges the contents of the `.sth` directory with the `.pjl` directory.

```
dns> merge subtree .sth into subtree .pjl
```

recreate directory

`recreate directory` — Creates a duplicate directory in the source subtree as a new directory in the target subtree.

Format

```
recreate directory directory-name [as] directory newdirectory-name
```

Arguments

directory-name

The full name of the directory.

newdirectory-name

The new name of the copy of the directory.

Description

This command creates a duplicate directory in the same subtree as a new directory in the target subtree. This is useful for resolving duplicate name conflicts that result from a merge of two subtrees. The command duplicates the directory only, not its contents. Its writable attribute values (`DNS$ACS`, `DNS$Convergence`, and `DNS$UpgradeTo`) are retained.

Note

Although all original access control entries (ACEs) are retained, the new directory also inherits all ACEs that may be propagated from the new parent directory in the target subtree. The principal executing this command is granted full access to the new directory.

The following attribute values are updated and do not match the values of the original directory: `DNS$AllUpTo`, `DNS$CTS`, `DNS$DirectoryVersion`, `DNS$InCHName`, `DNS$ParentPointers`, `DNS$Replicas`, and `DNS$UTS`. This command does not delete or modify the source directory.

Access Rights

You must have read, write, and delete access to the directory in which you intend to re-create the source directory.

Example

The following command re-creates the existing directory `.sales.quar1` as a new directory named `.mkt.quar1`.

```
dns> recreate directory .sales.quar1 as directory .mkt.quar1
```

recreate link

`recreate link` — Creates a duplicate soft link in the source subtree as a new soft link in the target subtree.

Format

```
recreate link link-name [as] link newlink-name
```

Arguments

link-name

The full name of the soft link.

newlink-name

The new name of the copy of the soft link. If you specify the name of an existing directory in the target subtree, the soft link is re-created in that directory with its original link name.

Description

This command creates a copy of a soft link with a new full name. This is useful for resolving duplicate name conflicts that result from a merge of two subtrees. The soft link's writable attribute values are retained, but `DNS$CTS` and `DNS$UTS` attribute values are not preserved.

Note

Although all original access control entries (ACEs) are retained, the new soft link also inherits all ACEs that may be propagated from the new parent directory in the target subtree. The principal executing this command is granted full access to the new soft link.

Asterisk wildcards are acceptable in both arguments. This command does not modify or delete the source soft link. For more information on managing soft links, see Chapter 9.

Access Rights

You must have read, write, and delete access to the directory in which you intend to re-create the soft link.

Example

The following command re-creates all soft links that exist in the `.sales` directory as new soft links in the `.mkt` directory.

```
dns> recreate link .sales.* as link .mkt.*
```

recreate object

`recreate object` — Creates a duplicate object entry in the source subtree as a new object entry in the target subtree.

Format

```
recreate object object-name [as] object newobject-name
```

Arguments

object-name

The full name of the object entry.

newobject-name

The new name of the copy of the object entry. If you specify the name of an existing directory in the target subtree, the object is re-created in that directory with its original object name.

Description

This command creates a copy of an object entry with a new full name. This is useful for resolving duplicate name conflicts that result from a merge of two subtrees. The object's writable attribute values are retained, but `DNS$CTS` and `DNS$UTS` attribute values are not preserved.

Note

Although all original access control entries (ACEs) are retained, the new object entry also inherits all ACEs that may be propagated from the new parent directory in the target subtree. The principal executing this command is granted full access to the new object entry.

Asterisk wildcards are acceptable in both arguments. This command does not modify or delete the source object entry.

Access Rights

You must have read, write, and delete access to the directory in which you intend to re-create the object entry.

Example

The following command re-creates the existing object entry `.sth.obj2` as a new object entry named `.pjl.obj4`.

```
dns> recreate object .sth.obj2 as object .pjl.obj4
```

remove clearinghouse access

`remove clearinghouse access` — Deletes an access control entry (ACE) from a clearinghouse's access control set (ACS).

Format

```
remove clearinghouse clearinghouse-name access principal
```

Arguments

clearinghouse-name

The name of the clearinghouse from which access is being deleted.

principal

The principal for whom access is being removed. You can specify a principal as a group name, a collection of principals denoted with wildcards (for example, `.org.name*`), or an individual name in the format `nodename.username`. To specify a DNS Version 1-style principal, use the format `nodename::username`.

Description

This command deletes an access control entry from a clearinghouse's access control set (ACS).

Access Rights

You must have control access to the clearinghouse whose ACS is being modified.

Example

The following command removes access for the user group `.testgroup` from the `.paris2_ch` clearinghouse.

```
dns> remove clearinghouse .paris2_ch access .testgroup
```

remove directory access

`remove directory access` — Deletes an access control entry (ACE) from a directory's access control set (ACS).

Format

```
remove directory directory-name access principal [as default]
```

Arguments

directory-name

The full name of the directory.

principal

The principal for whom access is being removed. You can specify a principal as a group name, a collection of principals denoted with wildcards (for example, `.org.name*`), or an individual name in the format `nodename.username`. To specify a DNS Version 1-style principal, use the format `nodename::username`.

Description

This command removes an access control entry from a directory's access control set. The optional argument `as default` indicates the ACE to be deleted is a default ACE. If this argument is not used, DECdns assumes the ACE is associated with the directory.

Access Rights

You must have control access to the directory whose ACS is being modified.

Example

The following command removes the default ACE for user `smith` on node `.admin` from the `.sales` directory.

```
dns> remove directory .sales access .admin.smith as default
```

remove group access

`remove group access` — Deletes an access control entry (ACE) from a group's access control set (ACS).

Format

```
remove group group-name access principal
```

Arguments

group-name

The full name of the group from which an ACE is being removed.

principal

The principal whose access is being removed. You can specify a principal as a group name, a collection of principals denoted with wildcards (for example, `.org.name*`), or an individual name in the format `nodename.username`. To specify a DNS Version 1-style principal, use the format `nodename::username`.

Description

This command deletes an access control entry from a group's access control set.

Access Rights

You must have write access to the group from which you are removing access.

Example

The following command removes the access rights of user `smith` on node `.sales.deneb` from the administrator group `.dns_admin`.

```
dns> remove group .dns_admin access .sales.deneb.smith
```

remove group member

`remove group member` — Deletes one member from an existing group.

Format

```
remove group group-name member [=] principal [as group]
```

Arguments

group-name

The full name of a group.

principal

The principal who is being deleted from the group. You can specify a principal as a collection of principals denoted with wildcards (for example, `.org.name*`), or an individual name in the format `nodename.username`. To specify a DNS Version 1-style principal, use the format `nodename:username`. Use the phrase `as group` to specify that the member you are removing is itself a group.

Description

This command deletes one member from an existing group.

Access Rights

You must have write access to the group from which you are removing a member.

Example

The following command removes the user `smith` on node `.sales.orion` from the group `.admin`.

```
dns> remove group .admin member .sales.orion.smith
```

remove link access

remove link access — Deletes an access control entry (ACE) from a soft link's access control set (ACS).

Format

```
remove link link-name access principal
```

Arguments

link-name

The full name of the soft link.

principal

The principal for whom access is being removed. You can specify a principal as a group name, a collection of principals denoted with wildcards (for example, `.org.name*`), or an individual name in the format `nodename.username`. To specify a DNS Version 1-style principal, use the format `nodename::username`.

Description

This command deletes an access control entry from a soft link's access control set.

Access Rights

You must have control access to the soft link whose ACS is being modified.

Example

The following command removes access for the user group `.testgroup` from the `.sales.asia` soft link.

```
dns> remove link .sales.asia access .testgroup
```

remove object

remove object — Deletes a value from an application-defined, set-valued attribute of an object entry.

Format

```
remove object object-name attribute-name [=] attribute-value
```

Arguments

object-name

The full name of the object entry.

attribute-name

The simple name of the attribute. Specify your own attribute name or one of the DECdns-defined attributes. Separate multiple attributes with commas.

attribute-value

The value of a particular attribute. You can express the values of application-defined attributes as quoted strings, "ps"; hexadecimal strings, %x FF00EE; or concatenations of them in parentheses, (%x0103 "ps").

Description

This command deletes a value from an application-defined, set-valued attribute of an object entry. If the value is not presently defined for the attribute, no error message is generated. Usually this task is accomplished through the client application.

Access Rights

You must have write access to the object entry whose attribute value you intend to remove or have control access to the parent directory.

Example

The following command removes the value of "ps" from the set-valued attribute `printcap` of the object entry named `.sales.east.deskprinter`.

```
dns> remove object .sales.east.deskprinter printcap "ps"
```

remove object access

`remove object access` — Deletes an access control entry (ACE) from an object entry's access control set (ACS).

Format

```
remove object object-name access principal
```

Arguments

object-name

The full name of the object entry.

principal

The principal for whom access is being removed. You can specify a principal as a group name, a collection of principals denoted with wildcards (for example, `.org.name*`), or an individual name in the format, `nodename.username`. To specify a DNS Version 1-style principal, use the format `nodename::username`.

Description

This command deletes an access control entry from an object entry's access control set.

Access Rights

You must have control access to the object entry whose ACS is being modified.

Example

The following command removes access for user `smith` on node `.sales.orion` from the object entry `.sales.work_disk2`.

```
dns> remove object .sales.work_disk2 access .sales.orion.smith
```

remove subtree access

`remove subtree access` — Removes an access control entry (ACE) from the access control set (ACS) of a directory and its contents, or from an entire subtree.

Format

```
remove subtree tree-name [...] access principal [exclude entry-type]
```

Arguments

tree-name

The name of the topmost directory in the subtree. When used without the optional recursion notation, the change applies only to the specified directory and the links and objects in that directory. The recursion notation causes the change to additionally apply to all child directories and their contents.

principal

The principal whose ACE is being removed. Principals can be specified as a group name or an individual name in the format `nodename.user`. To specify a DNS Version 1-style principal, use the format `nodename::username`.

entry-type

One or more of the following types of entries to exclude from the change: objects, links, or directories. You can exclude multiple directories with a single command. Use any combination of the following *entry-type* specifiers, separating multiple arguments with commas:

```
objects  
links  
directory directory-name
```

Description

This command removes an ACE from the access control set of a particular directory (and its contents) or from an entire subtree of directories. You can use the optional recursion notation (`. . .`) to modify the ACEs associated with all the child directories (and their contents). You can use the optional `exclude` argument to restrict the type of entries affected by this command. You can also use `exclude` with the recursion notation to prevent certain directories from being processed.

Access Rights

You must have control and write access to the directory you specify as well as to the contents of the directory. If you use the command recursively, you also need control and write access to all child directories (and their contents) of the directory you specify.

Example

The following command removes all ACEs that specify the principal `.pjl.smith` from the `.admin` directory and all its child directories.

```
dns> remove subtree .admin... access .pjl.smith
```

remove subtree group member

`remove subtree group member` — Removes a specified group member from all groups in the specified subtree.

Format

```
remove subtree tree-name [...] group member member-name [exclude directory directory-name]
```

Arguments

tree-name

The name of the topmost directory in the subtree. When used without the optional recursion notation, the change applies only to the specified directory and to the links and objects in that directory. The recursion notation causes the change also to apply to all child directories (and their contents).

member-name

The name of the group member that you want to remove.

directory-name

One or more directories and their associated ACEs to exclude from the change. You can exclude multiple directories with a single command. Separate multiple arguments with commas.

Description

This command removes a specified group member specification from all groups in the directory specified in *tree-name*. If you use the recursive notation (`. . .`), you can use the optional `exclude directory directory-name` argument to exclude groups named in a particular directory (and all its child directories) from group member modification. You can exclude multiple directories in a single command. Specify multiple directories in the following format:

```
exclude directory directory-name, directory-name, directory-name
```

Access Rights

You must have control access to the group whose member you intend to modify. If you use the command recursively, you must have control access to all groups affected by the command.

Example

The following command removes user `.pjl.smith` from membership in all groups named in the `.admin` directory.

```
dns> remove subtree .admin group member .pjl.smith
```

replace link

`replace link` — Deletes an individual soft link and replaces it with a new soft link to redirect lookups from the original location to the new location.

Format

```
replace link link-name [with] link newtree-name
```

Arguments

link-name

The full name of the soft link in its old location.

newtree-name

The full name of the directory into which the soft link has moved.

Description

This command deletes a specified soft link and replaces it with a soft link whose link target is the corresponding entry in the specified *newtree-name* directory. This command is useful when you need to redirect lookups only for a subset of a directory's contents. For more information on managing soft links, see Chapter 9.

Access Rights

You must have read, write, and delete access to the directory in which you intend to create the soft link.

Example

The following command replaces the soft link `.ceb.link1` with a soft link whose link target is the corresponding entry in the directory `.pjl`.

```
dns> replace link .ceb.link1 with link .pjl
```

replace object

`replace object` — Deletes a specified object entry and replaces it with a new soft link whose link target is the corresponding entry in a new location.

Format

replace object *object-name* [**with**] **link** *newtree-name*

Arguments

object-name

The full name of the object entry in its old location.

newtree-name

The full name of the directory to which the object entry was moved.

Description

This command deletes a specified object entry and replaces it with a soft link whose link target is the corresponding entry in the specified *newtree-name* directory. This command is useful when you need to redirect lookups only for a subset of a directory's contents.

Access Rights

You must have read, write, and delete access to the directory in which you intend to create the soft link.

Example

The following command replaces the object entry `.ceb.obj2` with a soft link whose link target is the corresponding entry in the directory `.pjl`.

```
dns> replace object .ceb.obj2 with link .pjl
```

replace subtree

replace subtree — Deletes the contents of a subtree that has just been merged or appended to a new location and replaces the information with soft links whose targets are the corresponding entries in the new location.

Format

replace subtree *tree-name* [...] [**with**] **link** *newtree-name* [**exclude** *entry-type*]

Arguments

tree-name

The full name of the topmost directory in the subtree.

newtree-name

The full name of the topmost directory in the target subtree.

entry-type

One or more of the following types of entries to exclude from the change: objects, links, or directories. Use any combination of the following *entry-type* specifiers, separating multiple arguments with commas:

```
objects  
links  
directory directory-name
```

Description

This command is useful after you have merged or appended a subtree that contains clearinghouse object entries. For all entries except clearinghouse object entries, this command deletes the entries in a directory specified in *tree-name* and replaces them with soft links. These soft links redirect lookups of the names from their old (source) locations to their new (target) locations. Using this command preserves both the clearinghouse object entry and its enclosing directory while deleting the directory's contents and replacing each name with an individual soft link. The optional recursion notation (. . .) also applies the delete and replace operation to the contents of all child directories of *tree-name*.

Access Rights

You must have read, write, and delete access to the directory you specify as well as to the contents of the directory. If you use the command recursively, you also need read, write, and delete access to all child directories (and their contents) of the directory you specify.

Example

The following command deletes the entries in the directory `.sales.quar1` and replaces them with soft links whose targets are their corresponding entries in `.total.quar1`.

```
dns> replace subtree .sales.quar1 with link .total.quar1
```

set directory

`set directory` — Modifies characteristics for the specified directory.

Format

```
set directory directory-name characteristic
```

Arguments

directory-name

The full name of the directory to be modified.

characteristic

The name and value of the characteristic to be modified. Specify one or more of the following:

```
DNS$Convergence [=] value  
DNS$InCHName [=] boolean
```



```
DNS$UpgradeTo [=] v.n
```

Description

This command modifies characteristics for the specified directory. You can specify one or more of the listed characteristics to be modified. Use a comma to separate characteristics. For more information on managing directories, see Chapter 7.

Characteristics

```
DNS$Convergence [=] value
```

Specifies the degree of consistency among replicas. Specify the *value* argument as one of the following:

Low	The next skulk distributes all DECdns updates that occurred since the previous skulk. Skulks occur at least once every 24 hours.
Medium	DECdns attempts to propagate an update to all replicas. If the attempt fails, the next scheduled skulk makes the replicas consistent. Skulks occur at least once every 12 hours.
High	DECdns attempts to propagate an update to all replicas. If that attempt fails (for example, if one of the replicas is unavailable), a skulk occurs within one hour. Background skulks occur at least once every 12 hours. VSI recommends that you use this setting temporarily (and briefly) because it uses extensive system resources.

By default, every directory inherits the convergence setting of its parent at creation time. The default setting of the root directory is *medium*.

```
DNS$InCHName [=] boolean
```

Specifies whether a directory or any of its descendants can store clearinghouse names. The *boolean* argument can be specified as one of the following:

True	The directory or its descendants can store clearinghouse names.
False	The directory or its descendants cannot store clearinghouse names. This is the default value.

```
DNS$UpgradeTo [=] v.n
```

Controls the upgrading of a directory from one version of DECdns to another. By modifying this attribute, you can initiate the upgrading of a directory to a higher version of DECdns. Specify the value as *v.n* where *v* indicates the major version number and *n* specifies the minor version number. There is no default.

Access Rights

You must have write access to the directory whose attribute you intend to modify.

Example

The following command sets a low convergence value on the `.mfg` directory.

```
dns> set directory .mfg DNS$Convergence = low
```

set directory to new epoch

set directory to new epoch — Reconstructs a directory's replica set, allowing you to exclude a replica or re-specify replica types.

Format

```
set directory directory-name to new epoch master clearinghouse-name [,read-only  
clearinghouse-name] [...] [,exclude clearinghouse-name]
```

Arguments

directory-name

The full name of the directory.

clearinghouse-name

The name of the clearinghouse in which an individual replica is located. The first *clearinghouse-name* specifies where the master replica is stored.

Description

This command reconstructs a directory's replica set, allowing you to exclude a replica or specify new replica types. You must list each existing replica and indicate whether an existing replica should be included in or excluded from the new replica set. You can include or exclude more than one replica; you can respecify zero (0) or more read-only replicas in the format *read-only clearinghouse-name*, *read-only clearinghouse-name*.

Note

When you include a replica, you are not creating it; you are simply specifying it as a member of the replica set. Use the `create replica` command to create a replica.

Likewise, when you exclude a replica, you are not deleting it; you are merely excluding it from the skulk process. DECdns clerks and servers continue to use the replica for lookups.

In general, exclude a replica when it is temporarily unavailable (its clearinghouse is temporarily unreachable), and you want a skulk to complete successfully. Include the replica again to its replica set as soon as possible after the clearinghouse on which it resides becomes available. Otherwise, lookup requests directed to the excluded replica may return outdated information.

Exclude a replica permanently when you are certain it will never be reachable again, such as when its clearinghouse has been corrupted and is being deleted. To remove a replica of a directory from a clearinghouse, use the `delete replica at clearinghouse` command. For more information on using the `set directory to new epoch` command, see Section 9.2.

Do not assume that the `set directory to new epoch` command completed successfully if you do not get any errors reported. You must check the skulk status on the master replica to determine if the command completed successfully. To check the skulk status, use the following `show replica` command:

```
show replica .directory clearinghouse .master_ch DNS$SkulkStatus
```

Be sure to specify the name of the clearinghouse that contains the master replica, as the skulk status is only available on the master replica.

After you use the `set directory to new epoch` command, a special skulk of the directory is automatically initiated. This skulk may require more time to complete than other, regularly scheduled skulks and will require more network resources.

Access Rights

You must have read and control access to all the replicas in the replica set. To change the type of replica, you must have write access to the clearinghouse that stores the replica whose type is being changed.

Example

The following command sets a new epoch for the directory `.mfg`. The master replica is in `.paris_ch`, and read-only replicas are in `.chicago1_ch` and `.seattle_ch`. The new replica set excludes the replica in `.ny1_ch`.

```
dns> set directory .mfg to new epoch master .paris1_ch, -
_> read-only .chicago1_ch, read-only.seattle_ch, exclude .ny1_ch
```

set directory to skulk

`set directory to skulk` — Skulks a directory immediately.

Format

```
set directory directory-name to skulk
```

Arguments

directory-name

The full name of the directory.

Description

This command skulks a directory immediately. The DECdns Control Program prompt (`dns>`) does not return until the skulk is complete. The amount of time for skulking to complete depends on the number of replicas of the directory, the number of updates to be propagated through the network, and the speed of the network connections between the nodes in the replica set. For more information on managing directories and skulking them, see Chapter 7.

Note

Under certain circumstances, it is possible to receive the `dns>` prompt before a skulk completes. To be absolutely positive that a skulk operation has succeeded, you should check the `DNS$SkulkStatus` attribute at the master replica for the directory. To check the skulk status, use the following `show replica` command:

```
show replica .directory clearinghouse .master_ch DNS$SkulkStatus
```

Be sure to specify the name of the clearinghouse that contains the master replica, as the skulk status is only available on the master replica.

Access Rights

You must have write access to the directory you intend to skulk.

Example

The following command initiates a skulk on the `.admin` directory.

```
dns> set directory .admin to skulk
```

set dns clerk

`set dns clerk` — Modifies characteristics of the clerk entity on the specified node.

Format

```
set [node node-id] dns clerk characteristic
```

Arguments

node-id

The name of the node. If you do not specify a node name, the local node is assumed.

characteristic

The name and the value of the characteristic to be modified. Specify one or any combination of the following for the *characteristic* argument:

Clerk Timeout [[=]secs]	Specifies the default timeout of client interface calls. If no response is received in the specified timeout, the clerk generates an error message. If you use this argument without specifying a value, it is set to the default (150 seconds).
Default Namespace [=]name	Designates the known namespace whose name is given as the default namespace for this clerk. A name must be supplied; there is no default.
Solicit Holddown [[=]secs]	Specifies the time (in seconds) to wait after initialization before soliciting advertisements from servers. If you use this argument without specifying a value, it is set to the default (15 seconds).

Description

This command modifies characteristics of the clerk entity on the specified node. You can specify one or more of the listed characteristics to be modified. Use a comma to separate characteristics. If you do not specify a value, the attribute is set to its default if that attribute has a default. You can also enter this command through the NCL interface. For more information on managing clerks, see Chapter 6.

Privileges Required

You must have the NET\$MANAGE rights identifier.

Example

The following command sets the `clerk timeout` to a value of 90 seconds for the clerk running on node `.eng.rigel`.

```
dns> set node .eng.rigel dns clerk clerk timeout 90
```

set dns clerk known namespace

`set dns clerk known namespace` — Modifies characteristics for the specified known namespace.

Format

```
set [node node-id] dns clerk known namespace identifier name [=]new-name
```

Arguments

node-id

The name of the node. If you do not specify a node name, the local node is assumed.

identifier

The identifier of the namespace. This is a required argument. You can use one of the following:

<code>name</code>	A simple name for the namespace.
<code>nscts</code>	The value of the namespace creation timestamp (NSCTS) that is automatically assigned when the namespace is created. The format of the NSCTS is 14 pairs of hexadecimal digits (<code>xx-xx</code>).

new-name

Specifies a new name for this known namespace, in effect, renaming the known namespace.

Description

This command modifies the Name attribute of a known namespace. The `nickname` attribute is not changed. You will find this command useful in the case of ambiguous nicknames, where a name was generated that you want to change. You can also enter this command through the NCL interface.

Privileges Required

You must have the NET\$MANAGE rights identifier.

Example

The following command renames the `IAF_1` namespace in the local clerk's cache with the new name `NDL`.

```
dns> set dns clerk known namespace IAF_1 name NDL
```

set group

set group — Modifies characteristics of the specified group.

Format

```
set group group-name DNS$GroupRevoke (expiration-time extension-time)
```

Arguments

group-name

The full name of the group.

expiration-time

A date and time after which a clerk must verify that a principal is still a member of a group. The value is specified as *yyyy-mm-dd-hh:mm:ss*.

extension-time

A period of time for which to renew the clerk's reliance on cached data when checking for group membership. After the specified expiration time, a clerk must verify group membership from the server. If the test is positive, the clerk adds the extension time to obtain a new expiration date. The extension time is specified as *ddd-hh:mm:ss*.

Description

This command modifies the attribute `DNS$GroupRevoke` for the specified group. This attribute specifies a timeout that determines how long a positive result from a group membership test operation may be cached by the clerk that issued the request. For more information on managing groups, see Chapter 5.

Access Rights

You must have write access to the group whose attribute you intend to modify.

Example

The following command specifies a group membership test of the group `.sales.admingroup` with an expiration time of December 31, 2019, that is extended 90 days if the clerk verifies membership.

```
dns> set group .sales.admingroup DNS$GroupRevoke -  
_> (2019-12-31-12:00:00 090-00:00:00)
```

set link

set link — Modifies characteristics of the specified soft link.

Format

```
set link link-name characteristic
```

Arguments

link-name

The full name of the soft link.

characteristic

The name and the value of the characteristic to be modified. Specify one or both of the following for the characteristic argument:

```
DNS$LinkTarget [=] fullname
DNS$LinkTimeout [=] [(expiration-time extension-time)]
```

Description

This command modifies characteristics of the specified soft link. Enter one or both of the following characteristics. If you enter both characteristics, separate them with a comma. For more information on managing soft links, see Chapter 9.

DNS\$LinkTarget

Specifies the full name of the directory, object entry, or other soft link to which the soft link points.

DNS\$LinkTimeout

Specifies a timeout value after which the soft link is either extended or deleted. The timeout value contains both an expiration time and an extension time. If a soft link expires and its target entry was deleted, the soft link is deleted. If the link still points to an existing entry, its life is extended by the extension time. Specify *expiration-time* in the format *yyyy-mm-dd-hh:mm:ss*. The default value of 0 means "never expire." Specify *extension-time* in the format *ddd-hh:mm:ss*. The default value is 000-00:00:00.

Access Rights

You must have write access to the soft link you intend to modify.

Example

The following command sets the expiration value of a soft link named `.eng.link01` to December 31, 2019, at 12:00 p.m. and sets the soft link's extension value to 90 days.

```
dns> set link .eng.link01 dns$linktimeout -
_> (2019-12-31-12:00:00 090-00:00:00)
```

set object

`set object` — Changes the value of a modifiable, single-valued attribute (including application-defined attributes) of an object entry.

Format

```
set object object-name attribute-name [=] attribute-value
```

Arguments

object-name

The full name of the object entry. Specify your own attribute name or one of the DECdns-defined attributes.

attribute-name

The name of the attribute to be modified.

attribute-value

The value of the attribute to be modified. You can express the values of application-defined attributes as quoted strings, "ps"; hexadecimal strings, %x FF00EE; or concatenations of them in parentheses (%x0103 "ps").

Description

This command changes the value of a modifiable, single-valued attribute (including application-defined attributes) of an object entry. This task is usually accomplished through the client application. Use a comma to separate attributes.

Access Rights

You must have write access to the object entry whose attribute you intend to modify or have control access to the parent directory.

Example

The following command changes the Q1 attribute of the object entry `.sales_records` to a value of 2.

```
dns> set object .sales_records Q1 %x2
```

show child

`show child` — Displays current information about the specified child pointer.

Format

```
show child child-name [attribute-specifier] [prepositional-phrase]
```

Arguments

child-name

A specific child name or a complete directory specification followed by a wildcard template for matching simple names of child pointers.

attribute-specifier

The name of an attribute or an attribute group. Enter one or more of the following attribute specifiers:

```
all [attributes]
all characteristics
DNS$ChildCTS
DNS$CTS
DNS$Replicas
DNS$UTS
```

prepositional-phrase

A phrase that affects the destination or content of command output. Specify one or more of the following prepositional phrases:

```
with attribute [relop] value
to file[=]filename
to extend file[=]filename
to terminal
```

Description

This command displays the names and values of the attributes or attribute groups named in *attribute-specifier*. If you do not supply any attribute specifier, the command displays all attributes and their values. You can use any combination of attribute specifiers in any sequence in a single command. Use a comma to separate specifiers.

Characteristics

The following are descriptions of valid characteristics:

DNS\$ChildCTS

Specifies the creation timestamp (CTS) of the child directory referenced by the child pointer.

DNS\$CTS

Specifies the CTS of the specified child pointer.

DNS\$Replicas

Specifies the address, CTS, and name of a set of clearinghouses where a copy of the child directory referenced by the child pointer is located. This attribute also specifies whether the directory in a particular clearinghouse is a master or read-only replica.

DNS\$UTS

Specifies the timestamp of the most recent update to an attribute of the child pointer.

Prepositional Phrases

You can affect the destination or content of command output by using prepositional phrases. Be sure to precede each of the following prepositional phrases with a comma and a space:

with attribute [relop] value

When used with a wildcard *child-name*, limits the output only to directories whose specified attributes have certain values.

to file[=]filename

Redirects the output to *filename*. If the file does not exist, this command creates it. If the file does exist, its contents are overwritten.

to extend file[=]filename

Appends the output to an existing *filename*. If the file does not exist, it is created.

to terminal

Directs the output to the terminal. This is the default option.

Access Rights

You must have read access to the directory in which the child pointer is located.

Example

The following command displays the creation timestamp (CTS) of the child directory `.sales` to which the child pointer refers.

```
dns> show child .sales dns$cts
```

The following command displays all attributes and their values for the `.admin` child pointer.

```
dns> show child .admin
```

```

                SHOW
                CHILD  IAF:.admin
                AT    17-APR-2019:13:59:01
                DNS$ChildUID = 2019-02-27-21:27:30.98/aa-00-04-00-2a-10
                DNS$Replicas (set) = :
                Clearinghouse's DNS$CTS = 2019-01-23-20:38:05.18/aa-00-04-00-de-11
                Tower 1 Floor 1 = 01 2c      (null)
                Tower 1 Floor 2 = 02      00 2c      ncacn_dnet_nsp
                Tower 1 Floor 3 = 04      (null)
                Tower 1 Floor 4 = 06      49 00 04 aa 00 04 00 2a 10 20
                Replica type = master
                Clearinghouse's Name = IAF:.admin1_ch
                DNS$Replicas (set) = :

                Clearinghouse's DNS$CTS = 2019-01-25-17:36:02.65/aa-00-04-00-de-11
                Tower 1 Floor 1 = 01 2c      (null)
                Tower 1 Floor 2 = 02      00 2c      ncacn_dnet_nsp
                Tower 1 Floor 3 = 04      (null)
                Tower 1 Floor 4 = 06      49 00 37 aa 00 04 00 49 dc 20
                Replica type = readonly
                Clearinghouse's Name = IAF:.admin2_ch
                DNS$CTS = 2019-02-27-21:27:31.79/aa-00-04-00-2a-10
                DNS$UTS = 2019-03-26-15:07:16.55/aa-00-04-00-2a-10

```

show clearinghouse

`show clearinghouse` — Displays DECDns attribute information about the specified clearinghouse.

Format

```
show clearinghouse clearinghouse-name [attribute-specifier] [prepositional-phrase]
```

Arguments

clearinghouse-name

A specific clearinghouse name or a complete directory specification followed by a wildcard template for matching simple names of clearinghouses.

attribute-specifier

The name of an attribute or an attribute group. Enter one or more of the following attribute specifiers:

```
all [attributes]
all characteristics
all identifiers
all status
DNS$ACS
DNS$CHCTS
DNS$CHDirectories
DNS$CHLastAddress
DNS$CHName
DNS$CHState
DNS$CHUpPointers
DNS$NSCTS
DNS$NSNickname
DNS$UTS
```

prepositional-phrase

A phrase that affects the destination or content of command output. Specify one or more of the following prepositional phrases:

```
with attribute [relop] value
to file[=]filename
to extend file[=]filename
to terminal
```

Description

This command displays the names and values of the attributes or attribute groups named in *attribute-specifier*. You can use any combination of attribute specifiers in any sequence in a single command. Use a comma to separate specifiers. If you do not supply any attribute specifier, the command displays all attributes and their values. The following is a description of clearinghouse attributes:

Characteristics

DNS\$ACS

Specifies the access control set for the clearinghouse.

DNS\$CHCTS

Specifies the time at which the clearinghouse was created.

DNS\$CHLastAddress

Specifies the current reported network address of the clearinghouse.

DNS\$CHUpPointers

Specifies pointers to clearinghouses that contain replicas closer to the root than those in this clearinghouse. If the attribute has no values, either this clearinghouse stores a replica of the root directory, or it has not yet obtained the necessary up-pointer information from other clearinghouses.

DNS\$NSCTS

Specifies the creation timestamp of the namespace of which the clearinghouse is a part.

DNS\$NSNickname

Specifies the nickname of the namespace of which the clearinghouse is a part.

DNS\$UTS

Specifies the timestamp of the most recent update to an attribute of the clearinghouse.

Identifier**DNS\$CHName**

Specifies the full name of the clearinghouse.

Status Attributes**DNS\$CHDirectories**

Specifies the full name and creation timestamp (CTS) of every directory that has a replica in this clearinghouse.

DNS\$CHState

Specifies the state of the clearinghouse.

Dying	The clearinghouse is being deleted.
On	The clearinghouse is running and available.
New	The clearinghouse is being created.

Prepositional Phrases

You can affect the destination or content of command output by using prepositional phrases. Be sure to precede each of the following prepositional phrases with a comma and a space:

with attribute [relop] value

When used with a wildcard *clearinghouse-name*, limits the output only to directories whose specified attributes have certain values.

to file[=]filename

Redirects the output to *filename*. If the file does not exist, this command creates it. If the file does exist, its contents are overwritten.

to extend file[=]filename

Appends the output to an existing *filename*. If the file does not exist, it is created.

to terminal

Directs the output to the terminal. This is the default option.

Access Rights

You need read access to the clearinghouse to display a list of known attributes or the value of an attribute.

Example

The following command displays the current values of the DNS\$ACS attribute associated with the .chicago1_ch clearinghouse.

```
dns> show clearinghouse .chicago1_ch DNS$ACS
```

The following command displays the current values of all the attributes associated with the local .chicago1_ch clearinghouse.

```
dns> show clearinghouse .chicago1_ch all
```

```

          SHOW
CLEARINGHOUSE IAF:.chicago1_ch
          AT 17-APR-2019:10:48:51
DNS$ACS (set) = :
          Flags = none
          Rights = read, write, delete, test, control
(V) Principal = IAF:.CHICAGO1.DNS$SERVER
DNS$ACS (set) = :
          Flags = propagate
          Rights = read, write, delete, test, control
(V) Principal = IAF:.chicago1.system
DNS$ACS (set) = :
          Flags = propagate, group
          Rights = read, write, delete, test, control
          Group = IAF:.chicago1.chi_admin
DNS$CHDirectories (set) = :
          CTS of Directory = 2018-09-04-18:52:56.19/aa-00-04-00-eb-27
          Name of Directory = .
DNS$CHLastAddress = :
Tower 1 Floor 1 = 01 2c      (null)
Tower 1 Floor 2 = 02        00 2c      ncacn_dnet_nsp
Tower 1 Floor 3 = 04        (null)
Tower 1 Floor 4 = 06        49 00 04 aa 00 04 00 2a 10 20
          DNS$CHName = IAF:.chicago1_ch
          DNS$CHState = on
          DNS$CHCTS = 2018-01-23-20:38:05.18/aa-00-04-00-de-11
DNS$CHUpPointers (set) = :
```

```
Clearinghouse's DNS$CTS = 2018-04-23-21:02:32.01/aa-00-04-00-de-11
  Tower 1 Floor 1 = 01 2c (null)
  Tower 1 Floor 2 = 02      00 2c      ncacn_dnet_nsp
  Tower 1 Floor 3 = 04      (null)
  Tower 1 Floor 4 = 06      49 00 18 aa 00 04 00 eb 61 20
  Replica type = readonly
Clearinghouse's Name = IAF:.chicago1_ch
  DNS$NSNickname = IAF
    DNS$NSCTS = 2018-04-23-21:02:32.01/aa-00-04-00-de-11
    DNS$CTS = 2019-01-23-20:38:05.18/aa-00-04-00-de-11
    DNS$UTS = 2019-04-17-14:04:41.88/aa-00-04-00-2a-10
```

show clearinghouse access

show clearinghouse access — Displays the access control set of a clearinghouse.

Format

```
show clearinghouse clearinghouse-name access [prepositional-phrase]
```

Arguments

clearinghouse-name

The name of the clearinghouse for which you want to see the access control set. It can be a specific clearinghouse name or a complete directory specification followed by a wildcard template for matching simple names of clearinghouses.

prepositional-phrase

A phrase that affects the destination or content of command output. Specify one or more of the following prepositional phrases:

```
to file[=]filename
to extend file[=]filename
to terminal
```

Description

This command displays the access control set of a clearinghouse.

Prepositional Phrases

You can affect the destination or content of command output by using prepositional phrases. Be sure to precede each of the following prepositional phrases with a comma and a space:

to file[=]filename

Redirects the output to *filename*. If the file does not exist, this command creates it. If the file does exist, its contents are overwritten.

to extend file[=]filename

Appends the output to an existing *filename*. If the file does not exist, it is created.

to terminal

Directs the output to the terminal. This is the default option.

Access Rights

You need read access to the clearinghouse.

Example

The following example displays the access control set of the `.ny_ch` clearinghouse.

```
dns> show clearinghouse .ny_ch access
```

The following example displays the access control set of the `.paris2_ch` clearinghouse.

```
dns> show clearinghouse .paris2_ch access
```

```
          SHOW
CLEARINGHOUSE IAF:.paris2_ch
          AT 17-APR-2019:13:49:08
DNS$ACS (set) = :
          Flags = none
          Rights = read, write, delete, test, control
(V) Principal = IAF:.PARIS2.DNS$SERVER
DNS$ACS (set) = :
          Flags = propagate
          Rights = read, write, delete, test, control
(V) Principal = IAF:.paris2.system
DNS$ACS (set) = :
          Flags = propagate, group
          Rights = read, write, delete, test, control
          Group = IAF:.paris_admin
```

show directory

`show directory` — Displays current information about the specified directory.

Format

```
show directory directory-name [attribute-specifier] [prepositional-phrase]
```

Arguments**directory-name**

A specific directory name or a complete directory specification followed by a wildcard template for matching simple names of directories.

attribute-specifier

The name of an attribute group or a particular attribute. Enter one or more of the following attribute specifiers:

```
all [attributes]
```

```

all characteristics
DNS$ACS
DNS$AllUpTo
DNS$Convergence
DNS$CTS
DNS$DirectoryVersion
DNS$InCHName
DNS$ParentPointer
DNS$Replicas
DNS$RingPointer
DNS$UpGradeTo
DNS$UTS

```

prepositional-phrase

A phrase that affects the destination or content of command output. Specify one or more of the following prepositional phrases:

```

with attribute [relop] value
to file[=]filename
to extend file[=]filename
to terminal

```

Description

This command displays the names and values of the attributes or attribute groups named in `attribute-specifier`. If you do not supply any attribute specifier, the command displays all attributes and their values. You can use any combination of attribute specifiers in any sequence in a single command. Use a comma to separate specifiers.

Characteristics

The following are descriptions of valid characteristics:

DNS\$ACS

Specifies the access control set for the directory.

DNS\$AllUpTo

Indicates the date and time of the last successful skulk on the directory. All replicas of the directory are guaranteed to have received all updates whose timestamps are less than the value of this characteristic.

DNS\$Convergence

Specifies the degree of consistency among replicas. This attribute's value can be one of the following:

Low	The next skulk distributes all updates that occurred since the previous skulk. Skulks occur at least once every 24 hours.
Medium	DECdns attempts to propagate an update to all replicas. If the attempt fails, the next scheduled skulk makes the replicas consistent. Skulks occur at least once every 12 hours.

High	DECdns attempts to propagate an update to all replicas. If the attempt fails (for example, if one of the replicas is unavailable), a skulk occurs within one hour. Background skulks will occur at least once every 12 hours. Use this setting temporarily and briefly, because it uses extensive system resources.
------	---

By default, every directory inherits the convergence setting of its parent at creation time. The default setting of the root directory is `medium`.

DNS\$CTS

Specifies the creation timestamp (CTS) of the directory DECdns.

DNS\$DirectoryVersion

Specifies the current version of the directory. (The version is derived from the `DNS$DirectoryVersion` attribute of the clearinghouse in which the directory was created.) Multiple directory versions are supported in a namespace.

DNS\$InCHName

Specifies whether a directory or any of its descendants can store clearinghouse names. If this value is true, the directory can store clearinghouse names. If it is false, the directory cannot store clearinghouse names.

DNS\$ParentPointer

A pointer that links a child directory to its parent directory, allowing clerks and servers to navigate up and down the namespace hierarchy.

DNS\$Replicas

Specifies the address, creation timestamp (CTS), and name of every clearinghouse where a replica of this directory is located. This attribute also specifies whether the replica in a particular clearinghouse is a master or read-only replica.

DNS\$RingPointer

Contains the CTS of the next clearinghouse in the ring. This attribute is for internal use only.

DNS\$UpgradeTo

Controls the upgrading of a directory from one version of DECdns to another. By modifying this attribute, you can initiate the upgrading of a directory to a newer version of DECdns.

DNS\$UTS

Specifies the timestamp of the most recent update to an attribute of the directory.

Prepositional Phrases

You can affect the destination or content of command output by using prepositional phrases. Be sure to precede each of the following prepositional phrases with a comma and a space:

with attribute [relop] value

When used with a wildcard *directory-name*, limits the output only to directories whose specified attributes have certain values.

to file[=]filename

Redirects the output to *filename*. If the file does not exist, this command creates it. If the file does exist, its contents are overwritten.

to extend file[=]filename

Appends the output to an existing *filename*. If the file does not exist, it is created.

to terminal

Directs the output to the terminal. This is the default option.

Access Rights

You need read access to the directory to use the show command.

Example

The following command displays the creation timestamp (CTS), the time at which the `.admin` directory was created.

```
dns> show directory .admin dns$cts
```

The following command displays all attributes and their values for the `.admin` directory.

```
dns> show directory .admin
```

```
          SHOW
    DIRECTORY  IAF:.admin
           AT   03-MAR-2019:16:39:03

DNS$ACS (set) = :
    Flags = none
    Rights = read, write, delete, test, control
(V) Principal = IAF:.ABC.SYSTEM

DNS$ACS (set) = :
    Flags = none
    Rights = read, write, delete, test, control
(V) Principal = IAF:.ORION.DNS$SERVER

DNS$ACS (set) = :
    Flags = authenticated
    Rights = read, write, delete, test, control
(V) Principal = IAF:.admin.orion_ch
    DNS$AllUpTo = 2019-03-03-11:52:16.851/08-00-2b-10-27-f4

DNS$Convergence = medium
    DNS$CTS = 2018-07-22-15:09:49.102/08-00-2b-03-87-72

DNS$DirectoryVersion = 1.0
    DNS$Epoch = 2018-07-22-15:09:50.102/08-00-2b-03-87-72
    DNS$LastSkulk = 2019-03-03-11:52:16.851/08-00-2b-10-27-f4
    DNS$LastUpdate = 2019-03-03-11:52:16.671/08-00-2b-10-27-f4

DNS$ParentPointer = :
```

```

Parent's DNS$CTS = 2018-03-25-22:49:33.409/08-00-2b-03-87-72
  Timeout = :
  Expiration = 2019-03-04-11:52:16.581
  Extension = +1-00:00:00.000
DNS$Replicas (set) = :

Clearinghouse's DNS$CTS = 2018-03-25-22:49:33.409/08-00-2b-03-87-72
  Tower 1 Floor 1 = 01 2c (null)
  Tower 1 Floor 2 = 03 00 2c
  Tower 1 Floor 3 = 05 de c0
  Tower 1 Floor 4 = 06 49 00 04 aa 00 04 00 a1 13 21
  Tower 2 Floor 1 = 01 2c (null)
  Tower 2 Floor 2 = 03 00 2c
  Tower 2 Floor 3 = 04 (null)
  Tower 2 Floor 4 = 06 49 00 04 aa 00 04 00 a1 13 20
  Tower 3 Floor 1 = 01 2c (null)
  Tower 3 Floor 2 = 03 00 2c
  Tower 3 Floor 3 = 05 de c0
  Tower 3 Floor 4 = 06 41 45 41 87 15 00 41 08 00 2b 10
27 f4 21
  Tower 4 Floor 1 = 01 2c (null)
  Tower 4 Floor 2 = 03 00 2c
  Tower 4 Floor 3 = 04 (null)
  Tower 4 Floor 4 = 06 41 45 41 87 15 00 41 08 00 2b 10
27 f4 20
  Replica type = master
Clearinghouse's Name = IAF:.admin.orion_ch
  DNS$ReplicaState = on
  DNS$ReplicaType = master
  DNS$ReplicaVersion = 1.0
  DNS$RingPointer = 2018-03-25-22:49:33.409/08-00-2b-03-87-72
  DNS$UTS = 2019-03-03-11:52:16.671/08-00-2b-10-27-f4

```

show directory access

show directory access — Displays the access control set of a directory.

Format

show directory *directory-name* **access** [*prepositional-phrase*]

Arguments

directory-name

A specific directory name or a complete directory specification followed by a wildcard template for matching simple names of directories.

prepositional-phrase

A phrase that affects the destination or content of command output. Specify one or more of the following prepositional phrases:

```

to file[=]filename
to extend file[=]filename

```

to terminal

Description

This command displays the access control set of a directory.

Prepositional Phrases

You can affect the destination or content of command output by using prepositional phrases. Be sure to precede each of the following prepositional phrases with a comma and a space:

to file[=]filename

Redirects the output to *filename*. If the file does not exist, this command creates it. If the file does exist, its contents are overwritten.

to extend file[=]filename

Appends the output to an existing *filename*. If the file does not exist, it is created.

to terminal

Directs the output to the terminal. This is the default option.

Access Rights

You must have read access to the directory.

Example

The following command displays the access control set of the directory `.sales` and stores the output in a file called `sdshow`.

```
dns> show directory .sales access, to file sdshow
```

The following command displays the access control set of the directory `.admin`.

```
dns> show directory .admin access
```

```
          SHOW
    DIRECTORY IAF:.admin
           AT 17-APR-2019:14:54:54
DNS$ACS (set) = :
           Flags = none
           Rights = read, write, delete, test, control
(V) Principal = IAF:.ABC.SYSTEM
DNS$ACS (set) = :
           Flags = none
           Rights = read, write, delete, test, control
(V) Principal = IAF:.ORION.DNS$SERVER
DNS$ACS (set) = :
           Flags = authenticated
           Rights = read, write, delete, test, control
(V) Principal = IAF:.admin.orion_ch
DNS$ACS (set) = :
           Flags = default, propagate, group
           Rights = read, write, delete, test, control
```

```
Group = IAF:.ad_users
```

If directory `.admin` is replicated on mixed-version servers (DECdns Version 2 and DNS Version 1), the display of its access control set would include two styles of access control entries (DECnet Phase IV and Phase V), as in the following example:

```
dns> show directory .admin access
```

```

      SHOW
      DIRECTORY  IAF:.admin
      AT 17-APR-2019:14:54:54
      DNS$ACS (set) = :
      Flags = none
      Rights = read, write, delete, test, control
      (IV) Principal = ABC::SYSTEM
      (V) Principal = IAF:.ABC.SYSTEM
      DNS$ACS (set) = :
      Flags = none
      Rights = read, write, delete, test, control
      (IV) Principal = ORION::DNS$SERVER
      (V) Principal = IAF:.ORION.DNS$SERVER
      DNS$ACS (set) = :
      Flags = authenticated
      Rights = read, write, delete, test, control
      (V) Principal = IAF:.admin.orion_ch
      DNS$ACS (set) = :
      Flags = default, propagate, group
      Rights = read, write, delete, test, control
      Group = IAF:.ad_users

```

show dns clerk

`show dns clerk` — Displays current information about the specified DECdns clerk.

Format

```
show [node node-id] dns clerk [attribute-specifier]
```

Arguments

node-id

The name of the node. If you do not specify a node name, the local node is assumed.

attribute-specifier

The name of an attribute or an attribute group. Enter one or more of the following attribute specifiers:

```

all [attributes]
all characteristics
all counters
all status
Authentication Failures
Cache Bypasses

```

Cache Hits
Clerk Timeout
Creation Time
Default Namespace
Incompatible Protocol Errors
Miscellaneous Operations
Read Operations
Read Operations
Solicit Holddown
State
UID
Version
Write Operations

Description

This command displays the names and values of the attributes or attribute groups named in `attribute-specifier`. You can also enter this command through the NCL interface. You can use any combination of attribute specifiers in any sequence in a single command. Use a comma to separate specifiers. If you do not supply any attribute specifier, the command displays all identifiers and their values. The following is a description of the clerk attributes:

Characteristics

Clerk Timeout

Specifies the default timeout of client interface calls. If no response is received in the specified time, an error message is generated. The default is 150 seconds.

Default Namespace

Contains the name of the clerk's default namespace.

Solicit Holddown

Specifies the time (in seconds) to wait after initialization before soliciting advertisements from servers. The default is 15 seconds.

UID

Uniquely identifies the entity.

Version

Specifies the version of the DECdns architecture implemented by this clerk.

Counters

Authentication Failures

Specifies the number of times a requesting principal failed authentication procedures.

Cache Bypasses

Specifies the number of requests to read attributes for which the clerk was specifically directed by the requesting application to bypass its own cache. Instead, a server is contacted to get the requested

information. This counter does not account for requests that the clerk is unable to satisfy from the cache or for requests to look up names or enumerate the contents of directories.

Cache Hits

Specifies the total number of read requests directed to this clerk that were satisfied entirely by the information contained in its own cache. This figure accounts only for requests to read attribute values and does not include requests to look up names or enumerate the contents of directories.

Creation Time

Specifies the time when this entity was created.

Incompatible Protocol Errors

Specifies the number of times this clerk received a response to one of its own requests from a server running a protocol version of DECdns software that was incompatible with the protocol version of DECdns software the clerk was running. Clerk requests directed to servers running incompatible protocol versions do not complete.

Miscellaneous Operations

Specifies the number of operations other than read and write (that is, skulks, enumerating contents of directories, and so on) performed by this clerk.

Read Operations

Specifies the number of lookup operations performed by this clerk. This counter accounts only for requests to read attributes and does not include name lookups or enumerations of multiple names.

Write Operations

Specifies how many requests to modify data were processed by this clerk.

Status Attributes

State

Specifies the state of the DECdns clerk.

Broken	The DECdns clerk has a fatal error condition.
Initial	The DECdns clerk is in the process of initializing.
Off	The DECdns clerk is not available.
On	The DECdns clerk is running and available.
Shut	The DECdns clerk is in the process of an orderly shutdown.

Privilege Required

You must have the NET\$EXAMINE rights identifier.

Example

The following command displays the state of the clerk running on node `.mfg.ariel`.

```
dns> show node .mfg.ariel dns clerk state
```

The following command displays all attributes of the clerk running on the local node.

```
dns> show dns clerk all
```

```
Node 0:. DNS Clerk
```

```
AT 2019-04-16-15:18:12.014-04:00I0.173
```

```
Status
```

```
State = On
```

```
Characteristics
```

```
Version = V2.0.0
Clerk Timeout = 0-00:01:00.000I0.000 Seconds
Solicit Holddown = 0-00:00:15.000I0.000 Seconds
UID = D370CD10-DC0B-11B8-AB12-07001C0DC09D
Default Namespace = IAF
```

```
Counters
```

```
Creation Time = 2019-04-16-18:26:49.543+00:00I0.000
Incompatible Protocol Errors = 0
Authentication Failures = 0
Read Operations = 7304
Cache Hits = 2994
Cache Bypasses = 1734
Write Operations = 1090
Miscellaneous Operations = 3100
```

show dns clerk known namespace

show dns clerk known namespace — Displays current information about the specified namespace.

Format

```
show [node node-id] dns clerk known namespace identifier [attribute-specifier] [prepositional-phrase]
```

Arguments

node-id

The name of the node. If you do not specify a node name, the local node is assumed.

identifier

The identifier of the namespace. You can use one of the following identifiers: the simple name for the namespace, which can contain wildcard characters, or the NSCTS, which is the value of the namespace creation timestamp that is automatically assigned when the namespace is created. The format of the NSCTS is 14 pairs of hexadecimal digits (*xx-xx*).

attribute-specifier

The name of an attribute or an attribute group. Enter one or more of the following attribute specifiers:

```
all [attributes]
all characteristics
all counters
all identifiers
all status
Ambiguous
Creation Time
Explicit Creation
Name
Nickname
NSCTS
UID
```

prepositional-phrase

A phrase that affects the content of command output. Specify the following prepositional phrase:

```
with attribute [relop] value
```

Description

This command displays the names and values of the attributes or attribute groups named in `attribute-specifier`. You can also enter this command through the NCL interface. You can use any combination of attribute specifiers in a single command. Use a comma to separate the specifiers. If you do not supply any attribute specifier, the command displays all identifiers and their values. The following are descriptions of valid characteristics, counters, identifiers, and status attributes:

Characteristics**UID**

Uniquely identifies the entity.

Counters**Creation Time**

Specifies the time when the clerk added this known namespace to its cache.

Identifiers**Name**

Specifies an external, human-readable name by which the namespace can be identified. If the namespace nickname is unique, the Name is the same as the Nickname. Otherwise, the name is generated by appending `_n` to the nickname for some value of `n` that makes it unique. The Ambiguous attribute is then set to true for the known namespace.

NSCTS

Specifies the creation timestamp of the namespace.

Status Attributes

Ambiguous

Indicates whether the nickname for this namespace is ambiguous; that is, more than one namespace known to this clerk has the same nickname. If true, the namespace nickname is ambiguous. If false, the namespace nickname is unique.

Explicit Creation

Specifies whether the namespace was created by a `create` command. If false, the namespace was created by the clerk itself.

Nickname

The name given to the namespace when it was created.

Prepositional Phrases

You can affect the content of command output by using prepositional phrases. Be sure to precede the following prepositional phrase with a comma and a space:

with attribute [relop] value

When used with a known namespace nickname wildcard, limits the output only to a namespace whose specified attribute has a certain value.

Privilege Required

You must have the NET\$EXAMINE rights identifier.

Example

The following command displays the identifiers of all namespaces with ambiguous nicknames.

```
dns> show dns clerk known namespace *, with ambiguous=true
```

The following command displays all of the attributes of the namespace on node `.oberon`.

```
dns> show node .oberon dns clerk known namespace * all
```

```
Node oberon:. DNS Clerk Known Namespace AA-00-01-00-01-FC-A0-4C-  
FF-8C-06-64-94-00  
AT 2019-04-16-17:39:42.765-04:00I0.112
```

Identifiers

```
NSCTS           = AA-00-01-00-01-FC-A0-4C-FF-8C-06-64-94-00  
Name            = orion_ns
```

Status

```
Nickname           = orion_ns
Ambiguous           = False
Explicit Creation   = False
```

Counters

```
Creation Time       = 2019-04-16-18:55:14.407+00:00I0.000
```

show dns clerk manual nameserver

show dns clerk manual nameserver — Displays the knowledge in the clerk's cache about a server that exists across a wide area network (WAN).

Format

```
show [node node-id] dns clerk manual namespace name [attribute-specifier] [prepositional-phrase]
```

Arguments

node-id

The name of the node. If you do not specify a node name, the local node is assumed.

name

The name of the manual name server entity that you want to show. It can contain wildcard characters.

attribute-specifier

The name of an attribute or an attribute group. Enter one or more of the following attribute specifiers:

```
all [attributes]
all characteristics
all counters
all identifiers
all status
Creation Time
Failed Solicits
Last Solicit
Name
Successful Solicits
Towers
UID
```

prepositional-phrase

A phrase that affects the content of command output. Specify the following prepositional phrase:

```
with attribute [relop] value
```

Description

This command displays the names and values from the attributes or attribute groups named in `attribute-specifier`. You can also enter this command through the NCL interface. You can use any combination of attribute specifiers in a single command. Use a comma to separate the specifiers. If you do not supply any attribute specifier, the command displays all identifiers and their values. The following are descriptions of valid characteristics, counters, identifiers, and status attributes:

Characteristics

Towers

Specifies the DECnet Phase V address of the server that this entity represents.

UID

Uniquely identifies the entity.

Counters

Creation Time

Specifies the time when the clerk created knowledge of this server in its cache.

Successful Solicits

The number of times the clerk made a successful solicit connection to the server and received clearinghouse advertisement data.

Failed Solicits

The number of times solicitation of clearinghouse advertisement data from the server failed.

Identifier

Name

Specifies an external, human-readable name by which the server can be identified.

Status Attributes

Last Solicit

Indicates the time when the clerk last tried to solicit this server.

Prepositional Phrases

You can affect the content of command output by using prepositional phrases. Be sure to precede the following prepositional phrase with a comma and a space:

with attribute [relop] value

When used with a wildcard *name*, limits the output only to directories whose specified attributes have certain values.

Privilege Required

You must have the NET\$EXAMINE rights identifier.

Example

The following command displays the Name attribute of the manual name server rns.

```
dns> show dns clerk manual nameserver rns Name
```

The following command displays all attributes of the manual name server emv.

```
dns> show dns clerk manual nameserver emv all
```

```
Node  DNS Clerk Manual Nameserver emv
AT 2019-04-02-15:21:21.326-04:00I0.127
```

Identifiers

```
Name = emv
```

Status

```
Last Solicit = 2019-04-02-19:19:59.596+00:00I0.000
```

Characteristics

```
UID = D86D22D5-07A5-11BC-9814-07001B1027C4
Towers =
{
  (
    [ DNA_SessionControlV2 , number=76 ] ,
    [ DNA_NSP ] ,
    [ DNA_OSInetwork , 41::00-04:BB-00-04-00-A7-11:20 ]
  )
}
```

Counters

```
Creation Time = 2019-04-02-19:19:59.596+00:00I0.000
Successful Solicits= 0
Failed Solicits = 0
```

show dns clerk remote clearinghouse

show dns clerk remote clearinghouse — Displays current information about the specified remote clearinghouse.

Format

```
show [node node-id] dns clerk remote clearinghouse clearinghouse-name [attribute-specifier]
[prepositional-phrase]
```

Arguments

node-id

The name of the node. If you do not specify a node name, the local node is assumed.

clearinghouse-name

A specific clearinghouse name or a complete directory specification followed by a wildcard template for matching simple names of clearinghouses.

attribute-specifier

The name of an attribute or an attribute group. Enter one or more of the following attribute specifiers:

```
all [attributes]
all characteristics
all counters
all identifiers
Creation Time
CTS
Miscellaneous Operations
Name
Read Operations
UID
Write Operations
```

prepositional-phrase

A phrase that affects the content of command output. Specify the following prepositional phrase:

```
with attribute [relop] value
```

Description

This command displays the names and values of the attributes or attribute groups named in `attribute-specifier`. You can also enter this command through the NCL interface. You can use any combination of attribute specifiers in a single command. Use a comma to separate the specifiers. If you do not supply any attribute specifier, the command displays all identifiers and their values. The following are descriptions of valid characteristics, counters, and identifiers:

Characteristics

UID

Identifies the remote clearinghouse entity.

Counters

Creation Time

Specifies the time when this entity was created.

Miscellaneous Operations

Specifies the number of operations other than read and write (that is, skulks, new epochs, and so on) performed by this clerk on the remote clearinghouse.

Read Operations

Specifies the number of lookup operations of any sort performed by the clerk on the remote clearinghouse.

Write Operations

Specifies the number of write operations performed by this clerk on the remote clearinghouse.

Identifiers

CTS

Indicates the creation timestamp (CTS) of this entity.

Name

Specifies the full name of the clearinghouse.

Prepositional Phrases

You can affect the content of command output by using prepositional phrases. Be sure to precede the following prepositional phrase with a comma and a space:

with attribute [relop] value

When used with a wildcard *clearinghouse-name*, limits the output only to directories whose specified attributes have certain values.

Privilege Required

You must have the NET\$EXAMINE rights identifier.

Example

The following command displays the CTS of the remote clearinghouse `.paris2_ch` cached by the clerk on node `.jmh`.

```
dns> show node .jmh dns clerk remote clearinghouse .paris2_ch cts
```

The following command displays all identifiers of the remote clearinghouse `.paris2_ch`.

```
dns> show dns clerk remote clearinghouse .paris2_ch all
```

```
Node 0:. DNS Clerk Remote Clearinghouse IAF:.paris2.paris2_ch  
AT 2019-04-17-11:25:00.786-04:00I0.495
```

Identifiers

```
CTS           = AB-01-03-00-CE-11-B0-1A-82-10-23-18-85-00  
Name          = IAF:.paris2.paris_ch
```

Characteristics

UID = 2C0435B0-CBF0-11B9-AC12-07001C0BC08D

Counters

Creation Time = 2019-04-17-10:03:18.988-04:00I0.142
Read Operations = 1735
Write Operations = 3100
Miscellaneous Operations= 1509

show dns server

show dns server — Displays current information about the specified server.

Format

show [**node** *node-id*] **dns server** [*attribute-specifier*]

Arguments

node-id

The name of the node. If you do not specify a node name, the local node is assumed.

attribute-specifier

The name of an attribute or an attribute group. Enter one or more of the following attribute specifiers:

all [attributes]
all characteristics
all counters
all status
Authentication Failures
Child Pointer Update Failures
Creation Time
Crucial Replica Removals Backed Out
Future Skew
Incompatible Protocol Errors
Maximum Protocol Version
Minimum Protocol Version
Possible Cycles
Read Accesses
Security Failures
Skulks Completed
Skulks Initiated
State
Times Lookup Paths Broken
UID
Version
Write Accesses

Description

This command displays the names and values of the attributes or attribute groups named in the `attribute-specifier` argument. You can also enter this command through the NCL interface. You can use any combination of attribute specifiers in a single command. Use a comma to separate the specifiers. If you do not supply any attribute specifier, the command displays all identifiers and their values. The following are descriptions of valid characteristics, counters, and status attributes:

Characteristics

Future Skew

Specifies the maximum amount of time that a timestamp can vary from local system time at the server node. This characteristic ensures data consistency.

Maximum Protocol Version

Specifies the maximum version of the DECdns clerk/server protocol that this particular DECdns server supports.

Minimum Protocol Version

Specifies the minimum version of the DECdns clerk/server protocol that this particular DECdns server supports.

UID

Uniquely identifies the entity.

Version

Specifies the version of the architecture implemented by this server.

Counters

Authentication Failures

Specifies the number of times a requesting principal failed authentication procedures.

Child Pointer Update Failures

Specifies the number of times the server background process was unable to contact all the clearinghouses where a replica of a particular child directory's parent directory is stored, and was, therefore, unable to apply the child updates that have occurred since the last skulk. This counter increases by 1 at each occurrence of the Cannot Update Child Pointer event.

Creation Time

Specifies the time when the DECdns server entity was created.

Crucial Replica Removals Backed Out

Specifies the number of times a user attempted (from this server) to remove a replica that is crucial to the connectivity of a directory hierarchy. The server background process prevents users from accidentally disconnecting lower-level directories from higher-level directories. When it detects an

attempt to remove a crucial replica, it will not execute the command to do so. This counter increases by 1 at each occurrence of the Crucial Replica event.

Incompatible Protocol Errors

Accounts for the total number of requests received by this server from a clerk running an incompatible protocol version. A server can communicate with any clerk running the same protocol version, or the version previous to the one it is running. This counter increases by 1 at each occurrence of the Incompatible Request event.

Possible Cycles

Specifies the number of times this server followed a chain and encountered an entry already in the chain. For example, a soft link is created that points to a series of links that eventually point back to the first link, or a group that is a member of itself. This counter increases by 1 at occurrence of the Possible Cycles event.

Read Accesses

Specifies the number of read operations directed to this DECdns server.

Security Failures

Specifies the number of times the Security Failures event was generated. This counter is increased whenever a DECdns server has insufficient access rights to a directory or object to perform either a client-requested action or a background operation.

Skulks Completed

Specifies the number of skulks that were successfully completed by this DECdns server.

Skulks Initiated

Specifies the number of skulks that were initiated by this DECdns server.

Times Lookup Paths Broken

Specifies the number of broken connections between clearinghouses on this server and clearinghouses closer to the root. Incoming requests to this server that require a downward lookup in the directory hierarchy may still succeed, but requests requiring lookup in directories closer to the root will fail. This counter increases by 1 at each occurrence of the Broken Lookup Paths event.

Write Accesses

Specifies the number of write operations to this DECdns server.

Status Attributes

State

Specifies the state of the DECdns server.

Broken	The server has a fatal error condition.
Initial	The server is initializing.
Off	The server is not available.

On	The server is running and available.
Shut	The server is undergoing an orderly shutdown.

Privileges Required

You must have the NET\$EXAMINE rights identifier.

Example

The following command displays information about the number of completed skulks on the server running on node .sales.orion.

```
dns> show node .sales.orion dns server skulks completed
```

The following command displays all identifiers of the server on the local node.

```
dns> show dns server all
```

```
show dns server all
```

```
Node 0:. DNS Server
```

```
AT 2019-04-18-17:07:37.093-04:00I2.147
```

Status

```
State = On
```

Characteristics

```
UID = 8BD2B21C-FCB43-11B8-A702-07001B2602FB
Minimum Protocol Version = V1.0.0
Maximum Protocol Version = V2.0.0
Future Skew = 0-00:05:00.000I0.000 Seconds
```

Counters

```
Creation Time = 2019-04-18-20:59:29.042+00:00I0.000
Incompatible Protocol Errors = 0
Authentication Failures = 0
Read Accesses = 1
Write Accesses = 0
Skulks Initiated = 0
Skulks Completed = 0
Times Lookup Paths Broken = 0
Possible Cycles = 0
Crucial Replica Removals Backed Out = 0
Child Pointer Update Failures = 0
Security Failures = 0
```

show dns server clearinghouse

show dns server clearinghouse — Displays current NCL attribute information about the specified clearinghouse.

Format

```
show [node node-id] dns server clearinghouse clearinghouse-name [attribute-specifier]  
[prepositional-phrase]
```

Arguments

node-id

The name of the node. If you do not specify a node name, the local node is assumed.

clearinghouse-name

A specific clearinghouse name or a complete directory specification followed by a wildcard template for matching clearinghouse simple names.

attribute-specifier

The name of an attribute or an attribute group. Enter one or more of the following attribute specifiers:

```
all [attributes]  
all characteristics  
all counters  
all identifiers  
all status  
Creation Time  
Data Corruptions  
Disable Counts  
CTS  
Enable Counts  
Name  
Read Accesses  
References Returned  
Skulk Failures  
State  
Times Clearinghouse Entry Missing  
Times Root Not Reachable  
UID  
Upgrades Not Possible  
Write Accesses
```

prepositional phrase

A phrase that affects the content of command output. Specify the following prepositional phrase:

```
with attribute [relop] value
```

Description

This command displays the names and values of the attributes or attribute groups named in *attribute-specifier*. You can also enter this command through the NCL interface. You can use any combination of attribute specifiers in a single command. Use a comma to separate the

specifiers. If you do not supply any attribute specifier, the command displays all identifiers and their values. The following are descriptions of valid characteristics, counters, identifiers, and status attributes:

Characteristics

CTS

Specifies the creation timestamp (CTS) of this clearinghouse.

UID

Uniquely identifies the entity.

Counters

Creation Time

Specifies the time when the clearinghouse entity was created.

Data Corruptions

Specifies the number of times the Data Corruption event was generated.

Disable Counts

Specifies the number of times the clearinghouse was disabled since it was last started.

Enable Counts

Specifies the number of times the clearinghouse was enabled since it was last started.

Read Accesses

Specifies the number of read operations directed to this clearinghouse.

References Returned

Specifies the number of requests directed to this clearinghouse that resulted in the return of a partial answer instead of satisfying the client's request.

Skulk Failures

Specifies the number of times a skulk of a directory, initiated from this clearinghouse, failed to complete—usually because one of the replicas in the replica set was unreachable.

Times Clearinghouse Entry Missing

Specifies the number of times the Clearinghouse Entry Missing event was generated.

Times Root Not Reachable

Specifies the number of times the Root Lost event was generated.

Upgrades Not Possible

Specifies the number of times the clearinghouse tried to upgrade a directory and failed.

Write Accesses

Specifies the number of write operations directed to this clearinghouse.

Identifier**Name**

Specifies the full name of the clearinghouse.

Status Attributes**State**

Specifies the state of the clearinghouse.

Broken	The clearinghouse has a fatal error condition.
Initial	The clearinghouse is in the process of initializing.
Off	The clearinghouse is not available.
On	The clearinghouse is running and available.
Shut	The clearinghouse is in the process of an orderly shutdown.

Prepositional Phrases

You can affect the content of command output by using prepositional phrases. Be sure to precede the following prepositional phrase with a comma and a space:

with attribute [relop] value

When used with a wildcard *clearinghouse-name*, limits the output only to directories whose specified attributes have certain values.

Access Rights

You need read access to the clearinghouse to display a list of known attributes or the value of an attribute.

Privilege Required

You must have the NET\$EXAMINE rights identifier.

Example

The following command displays the current value of the `Write Accesses` counter associated with the `.chicago1_ch` clearinghouse on server node `.midwest1`.

```
dns> show node .midwest1 dns server clearinghouse .chicago1_ch 0 -
_> Write Accesses
```

The following command displays all the attribute values associated with the `.dublin1_ch` clearinghouse on the local server.

```
dns> show dns server clearinghouse .dublin1_ch all
```

```
Node 0:. DNS Server Clearinghouse IAF:.dublin1_ch
AT 2019-04-17-11:16:21.598-04:00I0.447
```

Identifiers

```
Name = IAF:.dublin1_ch
```

Status

```
State = On
```

Characteristics

```
CTS = 07-00-1C-0D-C0-8C-05-61-3C-4D-78-70-92-00
UID = AB1234A5-CD67-87D1-EF23-07001BODC08C
```

Counters

```
Creation Time = 2018-04-17-13:58:51.369+00:00I0.000
Read Accesses = 0
Write Accesses = 0
References Returned = 0
Times Root Not Reachable = 0
Data Corruptions = 0
Skulk Failures = 0
Times Clearinghouse Entry Missing = 0
Directory Upgrade Failures = 0
Enable Counts = 1
Disable Counts = 0
```

show group

show group — Displays current information about the specified group.

Format

```
show group-name [attribute-specifier] [prepositional-phrase]
```

Arguments

group-name

A specific group name or a complete directory specification followed by a wildcard template for matching simple names of groups.

attribute-specifier

The name of an attribute or an attribute group. Enter one or more of the following attribute specifiers:

```
all [attributes]
all characteristics
DNS$ACS
```

DNS\$CTS
DNS\$GroupRevoke
DNS\$Members
DNS\$UTS

prepositional-phrase

A phrase that affects the destination or content of command output. Specify one or more of the following prepositional phrases:

```
with attribute [relop] value
to file[=]filename
to extend file[=]filename
to terminal
```

Description

This command displays the names and values of the attributes or attribute groups named in `attribute-specifier`. You can use any combination of attribute specifiers in a single command. Use a comma to separate the specifiers. If you do not supply any attribute specifier, the command displays all attributes and their values. The following are descriptions of valid characteristics:

Characteristics

DNS\$ACS

Specifies the access control set of the group.

DNS\$CTS

Specifies the creation timestamp of this group.

DNS\$GroupRevoke

Specifies a timeout that determines how long a positive result from a group membership test operation may be cached by the clerk that issued the request.

DNS\$Members

Specifies the DECdns full name of each member of the group. Members are specified as a group name, a collection of principals denoted with wildcards (for example, `.org.name*`), or an individual name in the format `nodename.username`. To specify a DNS Version 1-style principal, use the format `nodename::username`.

DNS\$UTS

Specifies the timestamp of the most recent update to an attribute of the group.

Prepositional Phrases

You can affect the destination or content of command output by using prepositional phrases. Be sure to precede each of the following prepositional phrases with a comma and a space:

```
with attribute [relop] value
```

When used with a wildcard *group-name*, limits the output only to directories whose specified attributes have certain values.

to file[=]filename

Redirects the output to *filename*. If the file does not exist, this command creates it. If the file does exist, its contents are overwritten.

to extend file[=]filename

Appends the output to an existing *filename*. If the file does not exist, it is created.

to terminal

Directs the output to the terminal. This is the default option.

Access Rights

You need read access to the group for which you want to display attribute information.

Example

The following command displays the full name of each member of the group `.sales_group1`.

```
dns> show group .sales_group1 DNS$members
```

The following command displays all the attributes of the group `.sales_group1`.

```
dns> show group .sales_group1 all
```

```

          SHOW
          GROUP  MEH:.sales_group1
             AT  17-APR-2019:13:53:21
DNS$ACS (set) = :
          Flags = none
          Rights = read, write, delete, test, control
(V) Principal = MEH:.MIDAS.SYSTEM

DNS$ACS (set) = :
          Flags = propagate
          Rights = read, write, delete, test, control
(V) Principal = MEH:.camelot.system
DNS$Class = DNS$Group

DNS$ClassVersion = 1.0
DNS$Members (set) = :
(V) Principal = MEH:.midas.system
DNS$Members (set) = :
(V) Principal = MEH:.midas.dns$server
DNS$Members (set) = :
(V) Principal = MEH:.midas.snow
DNS$CTS = 1991-06-12-18:57:31.18/aa-00-04-00-de-11
DNS$UTS = 2019-04-04-15:38:09.31/aa-00-04-00-eb-61

```

show group access

`show group access` — Displays the access control set of a group.

Format

`show group-name access [prepositional-phrase]`

Arguments

group-name

A specific group name or a complete directory specification followed by a wildcard template for matching simple names of groups.

prepositional-phrase

A phrase that affects the destination or content of command output. Specify one or more of the following prepositional phrases:

```
to file[=]filename
to extend file[=]filename
to terminal
```

Description

This command displays the access control set of a group.

Prepositional Phrases

You can affect the destination or content of command output by using prepositional phrases. Be sure to precede each of the following prepositional phrases with a comma and a space:

to file[=]filename

Redirects the output to *filename*. If the file does not exist, this command creates it. If the file does exist, its contents are overwritten.

to extend file[=]filename

Appends the output to an existing *filename*. If the file does not exist, it is created.

to terminal

Directs the output to the terminal. This is the default option.

Access Rights

You must have read access to the group.

Example

The following command displays the access control set of the group `.eng.testgroup`.

```
dns> show group .eng.testgroup access
```

The following command displays the access control set of the group `.lex.edgroup`.

```
dns> show group .lex.edgroup access
```

```

          SHOW
          GROUP   IAF:.lex.edgroup
          AT      17-APR-2019:14:02:42
DNS$ACS (set) = :
          Flags = none
          Rights = read, write, delete, test, control
(V) Principal = IAF:.MIDAS.SYSTEM
DNS$ACS (set) = :
          Flags = propagate
          Rights = read, write, delete, test, control
(V) Principal = IAF:.camelot.system
DNS$ACS (set) = :
          Flags = propagate
          Rights = read, test
(V) Principal = IAF:.*...
```

show link

show link — Displays current information about the specified soft link.

Format

```
show link-name [attribute-specifier] [prepositional-phrase]
```

Arguments

link-name

A specific name of a soft link or a complete directory specification followed by a wildcard template for matching simple names of soft links.

attribute-specifier

The name of an attribute or an attribute group. Enter one or more of the following attribute specifiers:

```

all [attributes]
all characteristics
DNS$ACS
DNS$CTS
DNS$LinkTarget
DNS$LinkTimeout
```

prepositional-phrase

A phrase that affects the destination or content of command output. Specify one or more of the following prepositional phrases:

```

with attribute [relop] value
to file[=]filename
to extend file[=]filename
to terminal
```

Description

This command displays the names and values of the attributes or attribute groups named in `attribute-specifier`. You can use any combination of attribute specifiers in a single command. Use a comma to separate the specifiers. If you do not supply any attribute specifier, the command displays all attributes and their values. The following are descriptions of valid characteristics:

Characteristics

DNS\$ACS

Specifies the access control set for the soft link.

DNS\$CTS

Specifies the creation timestamp of the soft link.

DNS\$LinkTarget

Specifies the full name of the directory, object entry, or other soft link to which the soft link points.

DNS\$LinkTimeout

Specifies a timeout value after which the soft link is either extended or deleted. The timeout value contains both an expiration time and an extension time. If the soft link does not point to anything when it is checked, it is deleted.

DNS\$UTS

Specifies the timestamp of the most recent update to an attribute of the soft link.

Prepositional Phrases

You can affect the destination or content of command output by using prepositional phrases. Be sure to precede each of the following prepositional phrases with a comma and a space:

with attribute [relop] value

When used with a wildcard *link-name*, limits the output only to directories whose specified attributes have certain values.

to file[=]filename

Redirects the output to *filename*. If the file does not exist, this command creates it. If the file does exist, its contents are overwritten.

to extend file[=]filename

Appends the output to an existing *filename*. If the file does not exist, it is created.

to terminal

Directs the output to the terminal. This is the default option.

Access Rights

You must have read access to the soft link.

Example

The following command displays the full name of the directory, object entry, or other soft link to which the soft link named `.sales.australia` points.

```
dns> show link .sales.australia DNS$LinkTarget
```

The following command displays all the attributes of the soft link `.sales.australia`:

```
dns> show link .sales.australia all
```

```

          SHOW
          SOFTLINK   IAF:.sales.australia
          AT        18-APR-2019:14:38:10
DNS$ACS (set) = :
          Flags = none
          Rights = read, write, delete, test, control
(V) Principal = IAF:.JWH.AUS_OSG

DNS$ACS (set) = :
          Flags = propagate, group
          Rights = read, write, delete, test, control
          Group = IAF:.name_sydney

DNS$ACS (set) = :
          Flags = group
          Rights = read, write, delete, test, control
          Group = IAF:.name_perth
DNS$LinkTarget = IAF:.notes.aus_os
DNS$LinkTimeout = :
          Expiration = 1583-10-25-00:00:00.0
          Extension = 0-00:00:00.000
          DNS$CTS = 2018-02-20-09:24:09.52/aa-00-04-00-de-11
          DNS$UTS = 2018-02-20-09:24:09.53/aa-00-04-00-de-11

```

show link access

`show link access` — Displays the access control set of a soft link.

Format

```
show link-name access [prepositional-phrase]
```

Arguments

link-name

A specific name of a soft link or a complete directory specification followed by a wildcard template for matching simple names of soft links.

prepositional-phrase

A phrase that affects the destination or content of command output. Specify one or more of the following prepositional phrases:

```
to file[=]filename
to extend file[=]filename
to terminal
```

Description

This command displays the access control set of a soft link.

Prepositional Phrases

You can affect the destination or content of command output by using prepositional phrases. Be sure to precede each of the following prepositional phrases with a comma and a space:

to file[=]filename

Redirects the output to *filename*. If the file does not exist, this command creates it. If the file does exist, its contents are overwritten.

to extend file[=]filename

Appends the output to an existing *filename*. If the file does not exist, it is created.

to terminal

Directs the output to the terminal. This is the default option.

Access Rights

You must have read access to the soft link.

Example

The following command displays the access control set of the soft link `.sales.australia` and stores the output in a file called `slshow`.

```
dns> show link .sales.australia access, to file=slshow
```

The following command displays the access control set of the soft link `.admin.australia`.

```
dns> show link .admin.australia access
```

```
          SHOW
SOFTLINK  IAF:..admin.australia
          AT  17-APR-2019:14:44:14
DNS$ACS (set) = :
          Flags = none
          Rights = read, write, delete, test, control
(V) Principal = IAF:.ARACHNE.WEB
DNS$ACS (set) = :
          Flags = propagate, group
          Rights = read, write, delete, test, control
          Group = IAF:.name_admin
DNS$ACS (set) = :
          Flags = propagate
          Rights = read, test
(V) Principal = IAF:.*.*
DNS$ACS (set) = :
```

```
Flags = propagate
Rights = read, test
Group = IAF:.root_servers
```

show object

show object — Displays current information about the specified object entry.

Format

```
show object-name [attribute-specifier] [prepositional-phrase]
```

Arguments

object-name

A specific object entry name or a complete directory specification followed by a wildcard template for matching simple names of object entries.

attribute-specifier

The name of an attribute or an attribute group. Enter one or more of the following attribute specifiers:

```
all [attributes]
all characteristics
DNA$Towers
DNS$ACS
DNS$Address
DNS$Class
DNS$ClassVersion
DNS$CTS
DNS$ObjectUID
DNS$UTS
```

prepositional-phrase

A phrase that affects the destination or content of command output. Specify one or more of the following prepositional phrases:

```
with attribute [relop] value
to file[=]filename
to extend file[=]filename
to terminal
```

Description

This command displays current information about the specified object entry. Application-defined attributes for an object are included in the output of this command (if they exist). Names and values of the attributes or attribute groups named in *attribute-specifier* are shown. You can use any combination of attribute specifiers in a single command. Use a comma to separate the specifiers. If you do not supply any attribute specifier, the command displays all attributes and their values. The following are descriptions of valid characteristics:

Characteristics

DNA\$Towers

Specifies the DECnet Phase V address of every node at which the object entry may be found. This attribute is used only by DECnet Phase V nodes and servers.

DNS\$ACS

Specifies the access control set for the object entry. Refer to Chapter 5 for information about access control sets and access control entries.

DNS\$Address

Specifies the DECnet Phase IV address of every node at which the object entry may be found. This attribute is used only by Phase IV nodes and servers.

DNS\$Class

Classifies objects according to the type of object being named. Client application programs can define their own classes for object entries that their application creates.

DNS\$ClassVersion

Allows the definition of an object class to be evolved over time (for example, by changing the definition of the class-specific attributes) without confusing the clients of the DECdns directory service.

DNS\$CTS

Specifies the creation timestamp of this object.

DNS\$ObjectUID

Specifies the unique identifier (UID) associated with the object entry. This attribute is optional and, if present, its value can be null. Clients are responsible for maintaining the UIDs of object entries that they are using; DECdns does not ensure that object entry UIDs are valid or unique.

DNS\$UTS

Specifies the timestamp of the most recent update to an attribute of the object entry.

In addition, application-specific attributes may exist for an object entry. See your application programmer for a list of application-defined attributes.

Prepositional Phrases

You can affect the destination or content of command output by using prepositional phrases. Be sure to precede each of the following prepositional phrases with a comma and a space:

with attribute [relop] value

When used with a wildcard *object-name*, limits the output only to directories whose specified attributes have certain values.

to file[=]filename

Redirects the output to *filename*. If the file does not exist, this command creates it. If the file does exist, its contents are overwritten.

to extend file[=*filename*]

Appends the output to an existing *filename*. If the file does not exist, it is created.

to terminal

Directs the output to the terminal. This is the default option.

Access Rights

You must have read access to the object entry.

Example

The following command lists the DNS\$CTS value of the object entry *new_dev*.

```
dns> show object new_dev DNS$CTS
```

The following command lists all the characteristics and their values of the object entry *rsm_dev*.

```
dns> show object rsm_dev all
```

```

          SHOW
OBJECT   IAF:.rsm_dev
          AT  17-APR-2019:14:48:56
DNS$ACS (set) = :
          Flags = none
          Rights = read, write, delete, test, control
(V) Principal = IAF:.MIDAS.SYSTEM
DNS$ACS (set) = :
          Flags = propagate, group
          Rights = test
          Group = IAF:.name_minos
DNS$Class = DNS$Group
DNS$ClassVersion = 1.0
DNS$CTS = 2018-07-22-15:09:49.102/08-00-2b-03-87-72
DNS$UTS = 2019-03-03-11:52:16.671/08-00-2b-10-27-f4

```

show object access

`show object access` — Displays the access control set of an object entry.

Format

```
show object-name access [prepositional-phrase]
```

Arguments

object-name

A specific object entry name or a complete directory specification followed by a wildcard template for matching simple names of object entries.

prepositional-phrase

A phrase that affects the destination or content of command output. Specify one or more of the following prepositional phrases:

```
to file[=]filename
to extend file[=]filename
to terminal
```

Description

This command displays the access control set of an object entry.

Prepositional Phrases

You can affect the destination or content of command output by using prepositional phrases. Be sure to precede each of the following prepositional phrases with a comma and a space:

to file[=]filename

Redirects the output to *filename*. If the file does not exist, this command creates it. If the file does exist, its contents are overwritten.

to extend file[=]filename

Appends the output to an existing *filename*. If the file does not exist, it is created.

to terminal

Directs the output to the terminal. This is the default option.

Access Rights

You must have read access to the object entry.

Example

The following command displays the access control set of the object entry `.sales.east.floor1Ln03` and stores the output in a file called `coshow`.

```
dns> show object .sales.east.floor1ln03 access, to file=coshow
```

The following command displays the access control set of the object entry `.psl_dev`.

```
dns> show object .psl_dev access
```

```
          SHOW
OBJECT   IAF:.psl_dev
        AT 17-APR-2019:15:01:14
DNS$ACS (set) = :
          Flags = none
          Rights = read, write, delete, test, control
(V) Principal = IAF:.MIDAS.SYSTEM
DNS$ACS (set) = :
          Flags = none
```

```
    Rights = test
(V) Principal = IAF:.*.DNS$SERVER
DNS$ACS (set) = :
    Flags = propagate, group
    Rights = read, write, delete, test, control
    Group = IAF:.name_dev
```

show replica

show replica — Displays current information about the specified replica.

Format

show directory-name [**at**] **clearinghouse** *clearinghouse-name* [*attribute-specifier*] [*prepositional-phrase*]

Arguments

directory-name

The full name of the directory.

clearinghouse-name

The full name of the clearinghouse.

attribute-specifier

The name of an attribute or an attribute group. Enter one or more of the following attribute specifiers:

```
all [attributes]
all characteristics
all identifiers
all status
DNS$CTS
DNS$Epoch
DNS$LastSkulk
DNS$LastUpdate
DNS$ReplicaState
DNS$ReplicaType
DNS$ReplicaVersion
DNS$RingPointer
DNS$SkulkStatus
```

prepositional phrase

A phrase that affects the destination or content of command output. Specify one or more of the following prepositional phrases:

```
to file[=]filename
to extend file[=]filename
to terminal
```

Description

This command displays the names and values from the attributes or attribute groups named in `attribute-specifier`. This command displays directory-specific attributes as well as per-replica attributes. If you do not supply any attribute specifier, the command displays all attributes and their values. You can use any combination of attribute specifiers in any sequence in a single command. The following are descriptions of valid characteristics, identifiers, and status attributes that pertain just to the replica:

Characteristics

DNS\$CTS

Specifies the creation timestamp (CTS) of the directory of which this replica is a copy.

DNS\$LastSkulk

Records the timestamp of the last skulk that began processing this particular replica of a directory. This will be zero for read-only replicas because they do not start processing for a skulk.

DNS\$LastUpdate

Records the timestamp of the last update to any attribute of the replica, or any change to the contents of the replica, including object entries, child pointers, and soft links. This will be zero for read-only replicas.

DNS\$ReplicaType

Specifies the type of this replica.

DNS\$ReplicaVersion

Specifies the version of this replica.

DNS\$RingPointer

Contains the CTS of the next clearinghouse in the ring. This attribute is for internal use only.

Identifier

DNS\$Epoch

Identifies a replica as part of a directory's complete set.

Status Attribute

DNS\$ReplicaState

Specifies the internal state of a replica. When you create or delete a replica, it goes through various states.

DNS\$SkulkStatus

If the replica is a master replica on the server for which this command is issued, this attribute contains information about the status of the skulk, such as whether it completed successfully or how it failed. The attribute does not display information for replicas mastered on DNS Version 1 servers.

Prepositional Phrases

You can affect the destination or content of command output by using prepositional phrases. Be sure to precede each of the following prepositional phrases with a comma and a space:

to file[=]filename

Redirects the output to *filename*. If the file does not exist, this command creates it. If the file does exist, its contents are overwritten.

to extend file[=]filename

Appends the output to an existing *filename*. If the file does not exist, it is created.

to terminal

Directs the output to the terminal. This is the default option.

Access Rights

You must have read access to the directory from which this replica was created.

Example

The following command displays the replica type of the `.eng` directory in the `.chicago2_ch` clearinghouse.

```
dns> show replica .eng at clearinghouse .chicago2_ch DNS$ReplicaType
```

The following command displays all the attributes of the replica of the `.eng` directory in the `.galbally_ch` clearinghouse.

```
dns> show replica .eng at clearinghouse .galbally_ch all
```

```

          SHOW
    REPLICAS IAF:.eng
          AT 17-APR-2019:15:14:39
DNS$ACS (set) = :
          Flags = none
          Rights = read, write, delete, test, control
(V) Principal = IAF:.MIDAS.SYSTEM
DNS$ACS (set) = :
          Flags = none
          Rights = read, write, delete, test, control
(V) Principal = IAF:.MINOS.DNS$SERVER
DNS$ACS (set) = :
          Flags = authenticated
          Rights = read, write, delete, test, control
(V) Principal = IAF:.galbally_ch
DNS$ACS (set) = :
          Flags = propagate, group
          Rights = read, write, delete, test, control
          Group = IAF:.name_dev
DNS$AllUpTo = 2019-04-17-15:13:09.45/aa-00-04-00-2a-10
DNS$Convergence = medium
DNS$DirectoryVersion = 1.0
DNS$Epoch = 2018-04-27-21:27:30.98/aa-00-04-00-2a-10

```

```
DNS$LastSkulk = 2019-04-17-15:13:09.45/aa-00-04-00-2a-10
DNS$LastUpdate = 2019-04-17-18:04:47.55/aa-00-04-00-2a-10
DNS$ParentPointer = :
Parent's DNS$CTS = 2018-07-21-18:56:49.42/aa-00-04-00-2a-10
Timeout = :
Expiration = 2019-04-18-18:04:47.35
Extension = 1-00:00:00.000
MyName = IAF:.eng
DNS$Replicas (set) = :
Clearinghouse's DNS$CTS = 2019-01-20-20:38:05.18/aa-00-04-00-de-11
Tower 1 Floor 1 = 01 2c (null)
Tower 1 Floor 2 = 02 00 2c ncacn_dnet_nsp
Tower 1 Floor 3 = 04 (null)
Tower 1 Floor 4 = 06 49 00 04 aa 00 04 00 2a 10 20
Replica type = master
Clearinghouse's Name = IAF:.galbally_ch
DNS$ReplicaState = on
DNS$ReplicaType = master
DNS$ReplicaVersion = 1.0
DNS$RingPointer = 2018-01-20-17:07:28.11/aa-00-04-00-de-11
DNS$CTS = 2018-05-28-21:27:30.98/aa-00-04-00-2a-10
DNS$UTS = 2019-04-17-18:04:47.55/aa-00-04-00-2a-10
DNS$SkulkStatus (set) = :
Last status = Success
```

Chapter 12. DECdns Problem Solving

This chapter provides tips for solving problems that may be related to the operation of DECdns. It contains information on the following:

- Isolating the source of a problem - see Section 12.1
- Using tracing facilities - see Section 12.2
- Locating DECdns files - see Section 12.3
- Solving clerk startup problems - see Section 12.4
- Solving server startup problems - see Section 12.5
- Solving common access control problems - see Section 12.6
- Handling clearinghouse creation failures - see Section 12.7
- Restoring a corrupted clearinghouse - see Section 12.8
- Restoring a deleted child pointer - see Section 12.9
- Restoring a missing clearinghouse object entry - see Section 12.10
- Handling node verification failures - see Section 12.11
- Breaking soft link loops and group loops - see Section 12.12
- Eliminating ambiguous namespace nicknames - see Section 12.13
- Handling communication errors - see Section 12.14
- Fixing clock synchronization errors - see Section 12.15
- Handling clerk and server software errors - see Section 12.16
- Handling skulk failures - see Section 12.17

12.1. Isolating the Source of a Problem: General Suggestions

Two basic rules should govern the process of isolating DECdns faults:

1. Prove you have a DECdns problem before making DECdns changes. If in doubt, do nothing to DECdns components and get help from support services.

Remember that not all DECdns problems originate from faults with the DECdns software. The majority of perceived DECdns clerk or server problems are caused by underlying network or operating system problems. For example, the network path to a particular DECdns server could be down or the system itself could have a resource problem.

Whatever you do, keep a log of your activities so that someone coming on to help later knows the entire story.

2. Most problems originating from DECdns actually involve access control problems.

To control access to DECdns information and to prevent accidental or malicious damage to the namespace, access control is applied on a node/user name basis. DECdns bars a person or process from accessing its information if the node/user name cannot be determined. Turn on event logging (the event dispatcher on DECnet Phase V systems) and enable any DECdns events. The DECdns server reports access control problems effectively. For more information on event logging, see the DECnet-Plus network management documentation. For more information on solving access control problems, see Section 12.7.

The first step to isolating the source of a problem is to collect and verify information about the software on the affected system. This is essential not only for fault isolation but also for providing important background information for any report that you must make to escalate problems not resolved at an early stage.

Obtain and verify the following:

1. Basic information about the DECnet system (Section 12.1.1).
2. Basic information about the clerk and (if applicable) server on your system (Section 12.1.2).
3. More specific information about the DECdns clerk (Section 12.1.3).
4. More specific information about the DECdns server (Section 12.1.4).

12.1.1. Obtain Basic DECnet Information

Collect key information about the DECnet system and its functionality. Verify the following information:

- That you have the required privileges for using the Network Control Language (NCL)—You use NCL to examine and manage DECnet Phase V entities.

You require the `NET$EXAMINE` and `NET$MANAGE` rights identifiers to use NCL for read and write operations.

- The DECnet-Plus software version of your system – Use the `ncl show implementation` command to determine the DECnet-Plus version.
- The DECnet Phase V node name and address—Use the `ncl show address` command to obtain the node name and address for your system. Ensure that backtranslation is indicated. The name of your node should be displayed to the right of the address as in the following example for node `ACME : . ZOO . MONKEY`:

```
49::00-30:AA-00-04-00-96-c0:20 (ACME : . ZOO . MONKEY)
```

If backtranslation is not evident, this could indicate a network or DECdns problem.

- Basic system information—Use the `show system` command to display system information. The display includes information about DECnet.

Look for information on the following:

- `NET$ACP` on Alpha systems, `NETACP` on VAX systems.
- `DNS$ADVER`—the DECdns clerk advertiser
- `LES$ACP`—core DECnet-Plus ACP

- REMACP—process required for inbound SET HOST to work
- DNS\$SERVER—DECdns server process (present only if the server software has been installed)
- NET\$EVD—DECnet-Plus event dispatcher
- NET\$MOP—DECnet-Plus MOP (Maintenance Operation Protocol) downline load process
- DTSS\$CLERK—Distributed time service clerk process
- DTSS\$SERVER—Distributed time service server process (present only if the server software has been installed)
- Addresses of adjacent routers—Each transport protocol enabled on the node has an associated routing port connecting the Transport layer to Routing. By displaying this port, you can show which network address is being used to get data to each transport. Use the following command:

```
ncl show routing port * all status
```

The most important remote nodes displayed are the adjacent routers on the LAN. These nodes are usually key to successful network connections. Use this command to check that your node can see an adjacent router.

12.1.2. Obtain Basic Clerk and Server Information

After determining the basic name and address information for your system, check the following:

- Is the DECdns clerk running?
- Is the node also a DECdns server?
- What are the DECdns clerk and server versions?

The following subsections explain how to check for this information.

12.1.2.1. Checking the DECdns Clerk

Check that the DECdns clerk is loaded and running normally. If it is not, attend to this problem before undergoing any further investigation. The DECdns clerk interoperates with the Session layer. A problem with the DECdns clerk could indicate a DECnet startup problem.

To check that the clerk is running, use NCL as in the following example:

```
ncl> show dns clerk all status
Node 0 DNS Clerk
at 2019-07-05-17:18:30.372+02:00I35.989
Status
  State      = On
```

If this command returns other output, such as the following, it indicates a problem.

```
[options]
command failed due to:
no such object instance
```

In this example, the clerk has been loaded but subsequently disabled and removed. This could suggest someone has shut down the DECdns clerk.

12.1.2.2. Checking the DECdns Server

If your system is a DECdns server, use NCL to check that the server is running and to check the clearinghouse. Though the OpenVMS show system command might indicate that the DECdns server is running on the system, certain server components might not be correctly loaded.

Use the NCL `show dns server all status` command to check the server, and the NCL `show dns server clearinghouse *` command to check the clearinghouse.

12.1.2.3. Checking the Clerk and Server Software Versions

The DECdns clerk and server software is bundled and shipped with the DECnet-Plus software. The DECdns version is identical to the DECnet-Plus version. If DECnet-Plus ECO kits have been installed, you may want to determine the ECO level of the DECdns software components.

DECdns Clerk Software Version

No single image contains all the clerk functions. However, a significant part of the software code exists in `SYS$LOADABLE_IMAGES:SYS$NAME_SERVICES`. Analyze this image to obtain a DECnet-Plus ECO number, using the following command:

```
$ ana/image/inter sys$loadable_images:sys$name_services
```

The DECdns clerk software version is indicated as the `image file identification` in the output.

DECdns Server Software Version

Analyze the `SYS$SYSTEM:DNS$SERVER` image to obtain a DECnet-Plus ECO number, using the following command:

```
$ ana/image/inter sys$system:dns$server
```

The DECdns server software version is indicated as the `image file identification` in the output.

12.1.3. Investigating the DECdns Clerk

Assuming you have the basic information about the clerk on your system described in Section 12.1.2, you can now investigate further to find information about the clerk. Objects of investigation may include the following:

- DECdns clerk cache
- DECdns clerk known namespaces

12.1.3.1. DECdns Clerk Cache Information

The DECdns clerk caches useful information about the results of lookup operations by DECdns servers. The information is periodically saved in a file and preserved across reboots. You can use the DECdns Control Program to dump the cache information (see Chapter 11). In addition, you can examine the cache files. (A cache file may not have been created at server startup because of insufficient resources.)

Using the DECdns Control Program to Obtain Cache Information

The DECdns Control Program `dump dns clerk cache` command dumps the cache information. This information can provide clues to the source of the problem, such as the following:

- Which DECdns servers the clerk knows
- Which namespaces the clerk can see (or has seen)
- The results of successful lookups in the namespace
- Clearinghouse information that has been cached in lookups

The `dump dns clerk cache` command dumps the cache information to your terminal. To facilitate examination of this information, redefine output from the DECdns Control Program to a file before you dump the cache. Then you can use an editor to search for useful information.

Removing Obsolete DNS\$CACHE Files

Occasionally, obsolete copies of the DECdns clerk cache file (`SYS$SYSTEM:DNS$CACHE.nnnnnnnnnn`) can accumulate and cause disk space problems on the system. DECdns uses only the files referenced in the `SYS$SYSTEM:DNS$CACHE.VERSION` file. DECdns normally deletes prior unreferenced versions of the file.

If you check the contents of the `SYS$SYSTEM:` directory and see more than one DECdns clerk cache file, check the `DNS$CACHE.VERSION` file to see which cache files DECdns is currently using and delete all prior cache files from the directory.

Using CDI Trace to Obtain Cache Information

You can run the CDI Trace utility to obtain trace information. Use the following command to run CDI \$TRACE, located in `SYS$SYSTEM:` `$ run sys$system:cdi$trace`

You can use the following procedure to redirect CDI\$TRACE output to a file:

1. Define a DCL foreign command symbol:

```
$ cdi$trace == "$cdi$trace"
```

2. Specify the name of the file to contain the CDI\$TRACE output:

```
$ cdi$trace trace.log
```

The output file may occasionally be missing the last few records of the trace. This is a known problem.

CDI\$TRACE has known problems when run during a LAT terminal session (on an LT device). A workaround is to issue the DCL `spawn` command first.

You can use NCL to manage two CDI naming cache parameters, the checkpoint interval and the timeout period, and you can flush entries from the in-memory naming cache. See the *VSI DECnet-Plus for OpenVMS Network Management Guide*.

Note

On OpenVMS systems, you can also use the Common Trace Facility to obtain naming trace information. Use the following command to invoke the Common Trace Facility: `$ Trace Start "SESSION CDI *"`

Including the CDI parameter restricts trace facility output to node name and address resolution messages.

12.1.3.2. DECdns Clerk Known Namespaces

When the DECdns clerk starts up, the clerk uses the default namespace defined during DECnet-Plus configuration. The DECdns clerk also may know about all other namespaces in the network in addition to others that have been configured. Use NCL to check which namespace names the clerk knows.

```
ncl> show dns clerk known namespace *
```

12.1.4. Investigating the DECdns Server

If your system is a DECdns server, and you have the basic information about the server on your system described in Section 12.1.2, investigate further to find information about the server. You can perform remote and local checks on the server.

12.1.4.1. Remote Checks on the Server

The checks described here can be performed remotely as well as locally. The network must be running and sufficient DECnet resources must be available on the DECdns server to allow incoming network management commands. If these commands fail, the DECdns server could still be running properly. The problem could be due to a DECnet or operating system fault.

Find out the name or address of the remote DECdns server by using the NCL `show dns clerk remote clearinghouse *`. However, the NCL command does not clearly indicate whether the server is a DECdns Version 2 or DNS Version 1 server. As an alternative, you can get the address of a remote node with which a connection failed by examining the `DNS$CHFAIL.LOG` file.

You can determine the node name from the clearinghouse NSAP, as explained in Section 12.1.4.3.

With the node and address information you obtain, perform the following checks using NCL, in the sequence shown:

1. `show node address dns server`

This command returns output such as the following:

```
Node 0 DNS Server at 2019-07-05-17:18:30.372+02:00I35.989
```

When this command fails to return information similar to this, the DECdns server is not running. It was either never started or has stopped running.

If this command hangs but other commands to the remote node work, it indicates a DECdns server problem that must be investigated locally.

2. Check that the DECdns server knows about its local clearinghouse files, as in the following example:

```
ncl> show node address dns server clearinghouse *
Node 0:. DNS Server Clearinghouse IAF:.dublin1_ch
AT 2019-04-17-11:16:21.598-04:00I0.447
Identifiers
Name = IAF:.dublin1_ch
```

If you get this output, the server has started and has found at least one DECdns clearinghouse file on disk. However, this does not mean the DECdns server is running now.

3. Next examine the clearinghouse counters, as in the following example:

```
ncl> show node address dns server clearinghouse * all counters
```

```
Node 0:. DNS Server Clearinghouse IAF:.dublin1_ch
AT 2019-04-17-11:16:30.598-04:00I0.447
```

Counters

```
Creation Time = 2019-04-17-13:58:51.369+00:00I0.000
Read Accesses          = 149679
Write Accesses         = 913
References Returned    = 31721
Times Root Not Reachable = 0
Data Corruptions      = 0
Skulk Failures        = 0
Times Clearinghouse Entry Missing = 0
Directory Upgrade Failures = 0
Enable Counts         = 1
Disable Counts        = 0
```

The counters in this example only indicate that the server has (at some time) performed a number of read and write operations successfully. They also indicate when the server was started (Creation Time). This could differ from the boot time, which can be determined from the Creation Time counter on routing. If the startup time for the server clearinghouse is later than the boot time for the system, it may indicate that someone has already attempted to perform some troubleshooting on the server. Note this in your log.

4. The `ncl dns server clear * replicas` command is crucial for checking if the server and clearinghouse are actually running properly. Unlike the earlier commands which only query DECnet and the DECdns server component, this command requires data to be read from the DECdns clearinghouse database. The following example shows the command and resulting output:

```
ncl> show node address dns server clearinghouse * replicas
```

```
Node 0:. DNS Server Clearinghouse IAF:.dublin1_ch
AT 2019-04-17-11:17:31.598-04:00I0.447
```

Status

```
Replicas =
{
  IAF:. ,
  IAF:.uvo ,
  IAF:.ilo ,
  IAF:.Applications ,
  IAF:.Accounting ,
  IAF:.Europe ,
  IAF:.Asia ,
  IAF:.Downunder ,
}
```

If the output includes replica information, the server is working properly. If the command hangs, or produces an error, the DECdns server is probably not working properly. Perform the local checks in Section 12.1.4.2.

If there is a significant difference in the elapsed time to execute the last two commands (displaying all counters and displaying replicas), it usually indicates that the performance of the operating system and network differs from the performance of the remote DECdns server itself.

Very slow access times to the replica data can indicate problems with process virtual memory or paging.

12.1.4.2. Local Checks on the Server

Check that the DECdns server process is present on the system, as in the following example:

```
$ show system/output=dns.tmp
$ search dns.tmp dns$server
0000027E DNS$Server LEF 9 52699 0 00:50:32.03 140958 49382
$ delete dns.tmp.*
```

12.1.4.3. Determining a Node Name from a Clearinghouse NSAP Address

During troubleshooting or routine management of your namespace, you may need to determine the node name of the system where a particular clearinghouse exists. For example, you may need to know the name of the node where the clearinghouse that stores the master replica of a directory resides. Because clearinghouses are not typically named after their host systems, you can use the following procedure to determine the node name:

1. Use the `show directory` command and specify the `DNS$Replicas` attribute to display the network service access point (NSAP) address of the clearinghouse. For example, suppose you need to determine the name of the node where the clearinghouse that stores the master replica of the root directory resides. The following command displays the `DNS$Replicas` attribute for the root directory of the IAF namespace.

```
dns> show directory . dns$replicas

          SHOW
    DIRECTORY  IAF:.
              AT  09-APR-2018:16:08:25
    DNS$Replicas (set) = :
    Clearinghouse's DNS$CTS = 2018-03-22-14:39:34.58/aa-00-04-00-de-11
      Tower 1 CTS = 2018-04-09-20:08:25.835/08-00-2b-0d-c0-9d
        Floor 1 = 01 2c (null)
        Floor 2 = 02 00 2c ncacn_dnet_nsp
        Floor 3 = 04 (null)
        Floor 4 = 06 49 00 37 aa 00 04 00 22 dc 20
      Replica type = readonly
    Clearinghouse's Name = IAF:.Chicago2_CH
    DNS$Replicas (set) = :
    Clearinghouse's DNS$CTS = 2018-07-30-20:32:42.82/aa-00-04-00-de-11
      Tower 1 CTS = 2018-04-09-20:08:25.835/08-00-2b-0d-c0-9d
        Floor 1 = 01 2c (null)
        Floor 2 = 02 00 2c ncacn_dnet_nsp
        Floor 3 = 04 (null)
        Floor 4 = 06 49 00 14 aa 00 04 00 7e 52 20
      Replica type = readonly
    Clearinghouse's Name = IAF:.Paris1_CH
    DNS$Replicas (set) = :
    Clearinghouse's DNS$CTS = 2018-01-12-18:15:01.77/aa-00-04-00-de-11
      Tower 1 CTS = 2018-04-09-20:08:25.835/08-00-2b-0d-c0-9d
        Floor 1 = 01 2c (null)
        Floor 2 = 02 00 2c ncacn_dnet_nsp
        Floor 3 = 04 (null)
        Floor 4 = 06 49 00 33 aa 00 04 00 0a ce 20
```

```

      Replica type = readonly
Clearinghouse's Name = IAF:.NY1_ch
DNS$Replicas (set) = :

```

The display shows that the master replica of the root directory is stored in the `.Chicago1_CH` clearinghouse and that the clearinghouse's NSAP address is `49 00 18 aa 00 04 00 eb 61 20` (see the information for the last clearinghouse listed in this display).

2. To determine the node name associated with this NSAP address, you must use the `show link` command to follow the soft link in the backtranslation tree (`.DNA_BackTranslation`) that points from the NSAP address (Floor 4 of the Tower address) to the corresponding node name (`DNS$LinkTarget`). The following command displays the node name stored in the backtranslation tree that corresponds to the NSAP address `49 00 18 aa 00 04 00 eb 61 20`, which you gathered in step 1. (Note that you must specify the NSAP address on the command line exactly as shown.)
 - a. Preface the address with `.DNA_BackTranslation`, then type `.%X` and the first pair of characters in the NSAP address (`.%X49`). This is the initial domain part (IDP) of the address.
 - b. Type `.%X` followed by the second and third pairs of characters (`.%X0018`). This is the local area portion of the address.
 - c. Type `.%X` again, this time followed by the next six pairs of characters (`.%Xaa000400eb61`). This is the node-ID portion of the address.

Ignore the last pair of characters (the selector portion of the address), in this case `20`.

- d. Specify the `DNS$LinkTarget` attribute at the end of the command.

```

dns> show link .DNA_BackTranslation.%X49.%x0018.%Xaa000400eb61 DNS
$LinkTarget

```

```

          SHOW
          SOFTLINK  IAF:.DNA_BackTranslation.%X49.%X0018.
%XAA000400EB6
          AT  09-APR-2018:16:14:51
DNS$LinkTarget = IAF:.orion

```

The output of the command shows that the name of the node corresponding to the NSAP address `49 00 18 aa 00 04 00 eb 61 20` is `IAF:.orion`.

12.2. Handling Communication Errors

When a clerk is unable to communicate with any DECdns server capable of processing its request, the following error message is displayed:

```
Unable to communicate with any DECdns server
```

12.2.1. Identifying Clearinghouses to Which Communication Failed

To troubleshoot this problem, first attempt to identify the clearinghouses with which your clerk tried to communicate. Examine the `SYS$MANAGER:DNS$CHFAIL.LOG` file, especially the last few entries. Output from the following example shows that the local clerk tried and failed to connect to three clearinghouses: `.Chicago1_CH`, `.NY2_CH`, and `.Paris1_CH`.

```

$ type sys$manager:dns$chfail.log

Wed Mar 18 18:49:24 2019
    PID: 39, DNS status: NOCOMMUNICATION, IPC status: NOAPPLICATION
    Clearinghouse: IAF:.Chicagol_CH
    Tower:
    04-00-02-00-01-2c-00-00-01-00-02-02-00-00-2c-01-00-04-00-00-01-
      00-06-0a-00-49-00-04-aa-00-04-00-c8-11-20
Wed Mar 18 21:32:03 2019
    PID: 39, DNS status: NOCOMMUNICATION, IPC status: NODEUNREACHABLE
    Clearinghouse: IAF:.NY2_CH
    Tower:
    04-00-02-00-01-2c-00-00-01-00-02-02-00-00-2c-01-00-04-00-00-01-
      00-06-0a-00-49-00-04-aa-00-04-00-c7-11-20
Wed Mar 18 21:43:35 2019
    PID: 39, DNS status: NOCOMMUNICATION, IPC status: TIMEDOUT
    Clearinghouse: IAF:.Paris1_CH
    Tower:
    04-00-02-00-01-2c-00-00-01-00-02-02-00-00-2c-01-00-04-00-00-01-
      00-06-0a-00-49-00-04-aa-00-04-00-a5-10-20

```

With this information, you can further investigate the cause of the communication failure to each of the clearinghouses. Table 12.1 explains the various elements of the DNS\$CHFAIL.LOG file:

Table 12.1. Elements of the DNS\$CHFAIL.LOG File

Field	Description				
DATE/TIME	This is the date and time of the lookup failure.				
PID	<p>This identifies the process that failed to look up information from DECdns. Frequently this process ID can be that of NET\$ACP, which might be looking up this information on behalf of you as a user (for example, you issue the SET HOST WATTS_NS: .dna_node.meta command, and the system looks up the node address of node .dna_node.meta). In this case, use the date/time information to determine which log file entry corresponds to your failure.</p> <p>Running \$ MCR CDI\$TRACE from another window while repeating the failing operation can also display more information. On DECdns server systems, you often find the process ID of the server itself here. The server is probably attempting to skulk with other systems or looking up access control information (an access control group) that is stored on another system. The server needs to do this to clear an incoming clerk lookup request for access to information in its own clearinghouse.</p>				
DNS status	In this case, DNS status will always be NOCOMM, but it will also log other DECdns status failures, such as the following:				
	<table border="1"> <tr> <td>NONSRESOURCES</td> <td>Sufficient resources are not available to the server to process your request. The server node may require tuning, more memory, or faster hardware.</td> </tr> <tr> <td>RESOURCEERROR</td> <td>No resources are available elsewhere, probably at the clerk. If the PID identifies NET\$ACP, the resource shortage probably involves a DECnet/tuning need or a memory leak. If the PID identifies</td> </tr> </table>	NONSRESOURCES	Sufficient resources are not available to the server to process your request. The server node may require tuning, more memory, or faster hardware.	RESOURCEERROR	No resources are available elsewhere, probably at the clerk. If the PID identifies NET\$ACP, the resource shortage probably involves a DECnet/tuning need or a memory leak. If the PID identifies
	NONSRESOURCES	Sufficient resources are not available to the server to process your request. The server node may require tuning, more memory, or faster hardware.			
RESOURCEERROR	No resources are available elsewhere, probably at the clerk. If the PID identifies NET\$ACP, the resource shortage probably involves a DECnet/tuning need or a memory leak. If the PID identifies				

Field	Description	
		another process, the process probably needs to have more memory resources.
IPC status	These status errors are returned to DECdns from DECnet. (IPC is the interface DECdns uses to communicate with DECnet.) Common values are:	
	MAXCONNECTEXCEE	The local node has too many connections open; that is, the number of open connections exceeds the value of the MAXIMUM TRANSPORT CONNECTION parameter defined for the transport protocol attempted for use, NSP or OSI. (Look at the last byte in the tower: 20 denotes NSP, while 21 denotes OSI transport.) If this error happens regularly, increase the maximum number of transport connections by using <code>NET \$CONFIGURE ADVANCED</code> .
	NOAPPLICATION	This means that a server is not running on the node whose address you have for the listed tower set. DECnet on the node itself is up and reachable.
	NODEUNREACHABLE	This means that the clerk could not contact the indicated clearinghouse using the tower that is listed. This error could mean the server node is down (or DECnet is not running there), the network is disconnected, the routers have marked the server as unreachable, or the clerk has an incorrect tower (DECnet address) cached for the clearinghouse (this is usually caused by moving the clearinghouse location).
	NOSCREOURCES	This means session control has no resources. This can happen on either end of the connection. It probably means that NET\$ACP has run out of memory, either due to misconfiguration, poor tuning, or memory leaks in DECnet or DECdns.
	NOTRANSPORTRESO	No transport resource. This indicates that the remote system (that is, the server to which you attempt to connect) has exceeded its maximum transport connections (because of too many open connections). See the description above for the MAXCONNECTEXCEE value.
	REMOTEDISCONN	Remote node disconnected. This happens when the remote server has accepted your connection and then decides to drop it. For example, if it could not authenticate your communications request properly or if the server is being shut down.
	TIMEDOUT	This means that DECnet or the clerk on your system gave up after waiting a length of time for a response. This can happen if the server or network failed in mid-request, or more often, if the server at the other end is overloaded, or hung, and is not responding after the initial lookup request was

Field	Description
	received. The default timeout for the DECdns Control Program can be modified as described in Section 4.6.
	<p>USERREJECT</p> <p>This usually means that the server is just coming up. (DECdns OpenVMS servers reject connections until they have fully read in the clearinghouse database.) On large namespaces where the clearinghouse may be over 50,000 blocks, this read action can take ten minutes or longer. Server configuration may also be restricting the number of simultaneous connections. See Section 10.4 for more information on server configuration and Section 12.6 for information on tuning your server to accommodate a higher number of simultaneous connections.</p>
Tower	This can indicate such problems as your DECdns cache file having outdated information for finding a clearinghouse, perhaps trying the wrong address or tower. Compare this address with the address for the node that hosts the clearinghouse you are failing to reach. If you can, log into that node and issue the <code>MCR NCL SHOW ADDRESS</code> command. This address must match one of the clearinghouse system's towers, or the connection will not work. If either NSP or OSI transport (but not both) were turned off on the node, you might also get this problem.

For DNS Version 1 servers, you can enable a very helpful DECnet event to see the reason for the "Unable to communicate with any server" error you are getting in `DNS$CONTROL`.

You need to enable the DNS event 353.5. The 353.5 event gives you the reason for the communication failure. You can see if the event is enabled by using `NCP SHOW KNOWN LOGGING` command (on the DECnet Phase IV node). Turn on the event with the `NCP SET LOG MONITOR EVENT 353.5` command. You may want to specify `353.*` to turn on all the DNS events. After you enable the event(s), issue the command that generates the communication error and wait a minute to receive the event via `OPCOM`. If you enable the event in `NCP` and still do not receive an `OPCOM` message, you may have an old version of the clerk image that did not implement this.

12.2.2. Determining Whether Communication Errors Are Caused by DECdns or DECnet

To verify that a communication failure is caused solely by a problem with DECdns, take the following steps in the order shown on the clerk system that received the error:

1. Set host to the local system:

```
$ set host 0
```

2. Set host again to the local system, this time specifying the numeric Phase IV-compatible network address (in decimal format) of the node (such as 5.4 in the following example):

```
$ set host 5.4
```

3. Set host to the DECnet Phase V-compatible address of the local node. To determine this address, use the `NCL show address` command, as shown:

```

$ mcr ncl
NCL>
NCL>show address

Node 0
at 2019-10-03-17:23:00.699-04:00I79.428
Identifiers

  Address =
  {
    (
      [ DNA_CMIP-MICE ] ,
      [ DNA_SessionControlV3 , number = 19 ] ,
      [ DNA_OSIttransportV1 , 'DEC0'H ] ,
      [ DNA_OSInetwork , 49::00-04:AA-00-04-00-97-11:21
(LOCAL:.IAF.DHARMA)
    ]
      ) ,
    (
      [ DNA_CMIP-MICE ] ,
      [ DNA_SessionControlV3 , number = 19 ] ,
      [ DNA_OSIttransportV1 , 'DEC0'H ] ,
      [ DNA_OSInetwork , 47:24:02-01-0A-04:08-00-2B-95-53-25:21
(LOCAL:.IAF.DHARMA)
    ]
      ) ,
    (
      [ DNA_CMIP-MICE ] ,
      [ DNA_SessionControlV2 , number = 19 ] ,
      [ DNA_OSIttransportV1 , 'DEC0'H ] ,
      [ DNA_IP , 0.0.0.0 ]
    ) ,
    (
      [ DNA_CMIP-MICE ] ,
      [ DNA_SessionControlV3 , number = 19 ] ,
      [ DNA_NSP ] ,
      [ DNA_OSInetwork , 49::00-04:AA-00-04-00-97-11:20
(LOCAL:.IAF.DHARMA)
    ]
      ) ,
    (
      [ DNA_CMIP-MICE ] ,
      [ DNA_SessionControlV3 , number = 19 ] ,
      [ DNA_NSP ] ,
      [ DNA_OSInetwork , 47:24:02-01-0A-04:08-00-2B-95-53-25:20

```

Use the first DECnet Phase V address shown, which in this example is 49::00-04:AA-00-04-00-97-11:21, and remove all punctuation and dashes: 490004AA000400971121. Now append this address to the prefix net\$ for the set host command as follows: \$ set host net\$490004AA000400971121

DECdns full names are not allowed for these commands.

If these login commands succeed, the communication failure to DECdns servers is probably caused by DECdns. If any of these login commands fails, the problem is more likely related to DECnet.

12.3. Handling Skulk Failures

This section discusses possible solutions to skulk problems.

12.3.1. General Considerations

If a skulk fails to complete, check the `DNS$SkulkStatus` attribute with the DECdns Control Program `show replica` command, as in the following example. This attribute can provide details on why the directory skulk failed. For troubleshooting purposes, specify the `DNS$SkulkStatus` attribute explicitly as in this example. Note that failure-related information provided by this attribute is also recorded in the `DNS$SERVER.LOG` file. The attribute does not display information for replicas mastered on DNS Version 1 servers.

```
DNS> show repli .dave at clear .fact_ch DNS$SkulkStatus
      SHOW
      REPLICA  AUTUMN:.dave
      AT      13-SEP-2019:10:45:00
DNS$SkulkStatus (set) = :
      Last status = Failure
      Phase = Spread
      Reason = Attempted reading DNS$REPLICASTATE at
clearinghouse AUTUMN:.dave.able_ch
      Reason = %DNS-E-NAMESERVERBUG, Software error detected in
server
```

In this example, an error occurred because the `.dave.able_ch` clearinghouse object or the clearinghouse itself was deleted or nonexistent. Rebuild the replica set to remove the missing clearinghouse (use the `set directory to new epoch` command).

If the `DNS$SkulkStatus` attribute does not help you identify the source of the problem, do the following:

- Verify that replicas of the directories being skulked do not exist in a corrupted clearinghouse. See Section 12.9 for more information about corrupted clearinghouses.
- Ensure that the number of members (principals) for any access group does not exceed 100. If this limitation is exceeded, the server process can crash during the skulk procedure. Because this skulk does not necessarily happen immediately (it can occur up to 24 hours after the group size limit was exceeded), diagnosis of this problem can be difficult.
- If the skulk failure occurs in an environment with both DECdns Version 2 and DNS Version 1 servers, see Section 12.3.2.

12.3.2. Skulk Problems in Mixed Server Environments

On DECdns Version 2 servers, the `DNS$CHDirectories` attribute for a clearinghouse object lists the set of directories replicated at that particular clearinghouse. If the following two conditions exist, the `DNS$CHDirectories` attribute may grow too large to be handled by the DNS Version 1 server.

- You have more than 200 directories stored in the DECdns Version 2 clearinghouse (for example, `.eng.host_ch`).
- You have a DNS Version 1 server that replicates the directory containing the DECdns server's clearinghouse object (for example, a DNS Version 1 server replicating the `.eng` directory).

The DNS server will have insufficient resources to support the skulk for the directory. The directory fails to skulk with the following status: `Insufficient local resources at the server node`

To prevent this problem, you can use a switch to delete, and disable updating of, the `DNS$CHDirectories` attribute. These actions do not affect the operation of the server because this attribute is read-only.

To set the switch, create a file called `dns.conf` in the `SYS$SYSDEVICE:[DNS$SERVER]` directory and add the following line: `dnsd.chdirectories_setting: switch_value`

where `switch_value` can be:

- 0 – Disables updating the `DNS$CHDirectories` attribute.
- 1 – Deletes the `DNS$CHDirectories` attribute and never updates it.
- 2 – Enables automatic updating of `DNS$CHDirectories` until a size threshold is reached, at which point the attribute is deleted.

To bring the switch into effect, stop and then restart the server (the `dns.conf` file is read once during server startup).

12.4. Clerk Tuning

DNS clerk tuning includes the following tasks:

- Ensuring that the `DNS$ADVER` process has adequate process quotas.
- Ensuring that the clerk cache size is optimal for the system memory configuration.

The next two sections discuss these tuning tasks.

12.4.1. Defining Quotas for the `DNS$ADVER` Process

One of the functions of the `DNS$ADVER` process is to serve as the process-based component of the DNS clerk software. If the `DNS$ADVER` process experiences quota problems you will notice clerk errors.

Five user-defined system logicals are available to define process quotas for the `DNS$ADVER` process:

- `DNS$ADVER_AST_LIMIT`
- `DNS$ADVER_BUFFER_LIMIT`
- `DNS$ADVER_EXTENT`
- `DNS$ADVER_MAX_WORKING_SET`
- `DNS$ADVER_PAGE_FILE`

These system logical names correspond to qualifiers on the `RUN` statement which are described in the OpenVMS documentation. If any of these system logical names are defined at the time that the `DNS$ADVER` process is started (by `SYS$SYSTARTUP:DNS_CLERK_STARTUP.COM`), then the values

defined for these system logical names are used instead of the default quotas. Typically, these system logical names are defined in the file `SYS$MANAGER:SYLOGICALS.COM`.

The default clerk configuration adequately supports two network adapters. Use these system logical names if you have a system configured with three or more ethernet controllers. You can also use these logicals to define increased quotas for the `DNS$ADVER` process when you receive a message on the console during startup that the clerk's cache is not initialized (`DNS$_NOCACHE,"Clerk cache not initialized"`).

In particular, you may need to modify the `DNS$ADVER_BUFFER_LIMIT` logical.

Generally, determine the value of the `DNS$ADVER_BUFFER_LIMIT` logical by using the greater of 300,000 or the value of the following formula:

```
DNS$ADVER_BUFFER_LIMIT # # # \u0001\u0002\u0001 \u0003\u0003\u0003
```

where `n` is the number of network adapters.

Selected default quotas for the `DNS$ADVER` process have also been increased for this release. The selected quotas that have been increased include direct I/O, enqueue limit, queue limit, buffer limit, and maximum working set.

12.4.2. Clerk Cache Size and the GBLPAGFIL System Parameter

On systems where the amount of physical memory has changed or the `GBLPAGFIL` system parameter has changed, it is important to make the clerk aware of this change. The DECdns clerk resizes the clerk cache file only when a sizing calculation determines that the file is less than whichever is smaller: 1,000 blocks or .5% of memory.

If the amount of physical memory available to a system has changed or if the `GBLPAGFIL` system parameter has been modified, check the `SYS$MANAGER:DNS$ADVER_ERROR.LOG` file. The DECdns clerk indicates in this file if it has calculated a new recommended cache size.

When you see the following message, fewer than 10 `GBLPAGFIL`s are available and the cache file was not created:

```
Insufficient Global Page File Limit - no cache
```

When this situation happens, increase the size of `GBLPAGFIL`, run `AUTOGEN`, and reboot your system to get a functioning DECdns clerk.

If the cache file size exceeds 75 percent of the available `GBLPAGFIL`, it is set to that figure (75 percent of the available `GBLPAGFIL`) so it does not use up all of the available `GBLPAGFIL`. The message `Cache Size ceiling exceeded` in the log file indicates that this has occurred. The maximum size of the clerk cache is 512 MB.

If the recommended change in the size of the cache file is substantial and you want DECdns to use the new cache size, take the following steps:

1. Shut down the DNS clerk.
2. Delete the existing cache files (`SYS$SYSTEM:DNS$CACHE.*`).
3. Reboot the system (do not start DECdns before rebooting – the cache sizing algorithm must run on a fresh boot of OpenVMS).

12.5. Solving Server Startup Problems

Usually a server startup problem involves a file configuration problem. Section 12.5.1 lists steps you can take to solve the problem on an OpenVMS system.

Take the following steps to solve DECdns server startup problems:

1. Check that the `SYS$MANAGER:DNS_FILES.TXT` file exists and contains the correct file name and location for the clearinghouse files.
2. Make sure that the `SYS$SYSDEVICE:[DNS$SERVER]` directory exists, even if the clearinghouse is located elsewhere.
3. If the clearinghouse files are on a disk other than the system disk, make sure the disk is mounted before DECnet starts up.
4. Make sure the disk on which the clearinghouse files are located has enough space to write out a second checkpoint file plus 5,000 blocks for the TLOG file.
5. Make sure that `SYS$MANAGER:NET$DNS_SERVER_STARTUP.NCL` and `SYS$STARTUP:DNS$SERVER_STARTUP.COM` exist.

If all these files seem correct, examine the `SYS$MANAGER:DNS$SERVER.LOG` files on the server system that failed to start up.

Note

Depending on the size of the disk and the speed of memory, the startup can take up to 30 minutes.

12.5.1. Server Startup Delay in a TCP/IP Environment

There can be a delay in the startup of the DECdns server when the server is using DECnet over TCP/IP connections. This delay is due to the time required for the server to obtain a non-zero IP address from DECnet and the PATHWORKS Internet Protocol (PWIP) software. The IP address is initially zero until it is updated by DECnet and PWIP with the actual IP address for the node.

12.6. Server Tuning

Server tuning is driven by two major factors:

- Clerk usage
- Database size

The next two sections discuss the tuning tasks related to these factors.

12.6.1. Tuning for Increased Clerk Use

A DECdns server is configured by default to accept up to 200 simultaneous network connections. If you anticipate a higher load than that for your server, take the following steps to allow the server to accommodate that load.

1. Edit the server configuration file, (`SYS$SYSDEVICE:[DNS$SERVER]DNS.CONF`), to increase the resources available to the server. In particular, modify the parameters in the following table as needed:

<code>dns.dnsd.ta_conn_quota</code>	Limits the number of clerk-to-server connections. The default is 200. Raise this value as needed for increased server load.
<code>dns.dnsd.back_conn_quota</code>	Limits the number of server-to-server connections. The default is 20. This is usually sufficient.
<code>dns.dnsd.maximum_handlers_quota</code>	Limits the number of request handlers available for clerk request processing. The default value is 200. This value should be equal to or slightly higher than the value specified for <code>dns.dnsd.ta_conn_quota</code> .
<code>dns.dnsd.maximum_buffers_quota</code>	Limits the number of buffers available for request handlers. The default is 200. This value should equal the value specified for <code>dns.dnsd.maximum_handlers_quota</code> .

See Section 12.6.3 for more information about the server configuration file.

2. You should also make several other changes:

- Check `DNS$SERVER_STARTUP.COM` for any process limits that will stop the server from accepting more links. `FILLM`, `ASTLM` can be increased if needed.

The default value of 100 for `FILLM` on a DECdns server limits the number of DECdns clerks that can connect to the server. This limitation causes the DECdns clerk to log a `USERREJECT` error into the `DNS$CHFAIL.LOG` file when the limit of 100 connections is exceeded. You can raise this limit by modifying the line in `SYS$STARTUP:DNS$SERVER_STARTUP.COM` that specifies `/FILLM=100`.

Note that the `ASTLM` value for the `NET$ACP` process also defaults to 100. This limits the number of connections that `NET$ACP` can process at any one time thereby limiting the number of clerk connections. Raise this value when increasing the server's `FILLM` value.

- Check the actual size of the clearinghouse database files. On OpenVMS

VAX systems, set `VIRTUALPAGECNT` to be at least three times the sum of the database file sizes (also known as the checkpoint file size). For example, if the checkpoint file is 80,000 blocks, set `VIRTUALPAGECNT` to the value 240,000 in `MODPARAMS.DAT` and do an `AUTOGEN` to activate any other new values.

You must also size the page files on the node accordingly. If the system has more than one page file, the individual page files must be at least as large as the checkpoint file. Because each OpenVMS process is assigned to a single page file, the total combined size of the page files is not useful to DECdns, because it can only use the capacity of one of them when it reads the entire clearinghouse checkpoint file into memory. Note also that DECdns is not guaranteed to use the larger page file if one page file is sufficiently large and others are not.

3. Now that the server will support more links than it did before, verify that the DECnet values for `NSP Maximum Transport Connections` and/or `OSI Transport Maximum`

Transport Connections are increased also. To find out the current number of links on a system, use the following NCL commands:

```
NCL> SHOW NSP CURRENTLY ACTIVE CONNECTIONS
NCL> SHOW OSI TRANSPORT CURRENTLY ACTIVE CONNECTIONS
```

12.6.2. Tuning for Increased Database Size

It is important to provide the DECdns server with adequate resources because the DECdns server uses an "in memory" database. VSI strongly recommends that users be generous with system quotas, especially the working set quota.

AUTOGEN does not correctly calculate the working set size required by the DECdns Server. The working set size depends on the size of your checkpoint file. The size of the working set typically varies from 50,000 to 250,000. Using working set sizes below 50,000 is generally not recommended.

If you need help on setting the quotas, contact your VSI representative to obtain the tools to monitor the quota.

12.6.3. The Server Configuration File - DNS.CONF

The DECdns server configuration file, `SYS$SYSDEVICE:[DNS$SERVER]DNS.CONF`, contains several parameters that allow you to control the following operational characteristics of the DECdns server:

- Access control
- Node verification
- Timer values
- Resource limits
- Replica pruning

Table 12.2 describes the available parameters.

Table 12.2. DNS.CONF Configuration Parameters

<code>dns.dnsd.acs_override</code>	<p>Disables access control if set to 1. The default setting is zero (access control checking on).</p> <hr/> <p>Caution</p> <p>While access control checking is overridden, any privileged or nonprivileged user on your network has complete read, write, delete, and control privileges to any object, directory, or clearinghouse managed on this server.</p>
<code>dns.dnsd.node_verification</code>	<p>Disables node verification if set to zero.</p> <p>The default setting is 1 (node verification enabled).</p>

	<p>If you set this option to 0, the server does not backtranslate the incoming address to verify that the incoming connection is actually coming from where the incoming connection claims it is coming from. With this disabled, servers are vulnerable to intentional or unintentional "node spoofing" where systems make updates to the namespace for which their node names are authorized but their addresses are not.</p>
<code>dns.dnsd.idle_conn_timeout</code>	<p>Time in seconds to wait while link is idle before disconnecting the link. The default value is 300 seconds (5 minutes). If this value is set too low, it results in excessive processing time to recreate links every time a request is processed. If set too high, it ties up resources for links that are not being used.</p>
<code>dns.dnsd.null_port_timeout</code>	<p>Time in seconds to wait before unconditionally disconnecting the link.</p> <p>The default value is 1800 seconds (30 minutes).</p> <p>The value should be set high enough to allow the longest command to complete execution. Typically, the longest command is set dir to new epoch which includes a skulk as the final part of its processing. Values for this parameter can range anywhere from a couple of minutes to 90 minutes depending on the size of the directory involved and delays present in the network.</p> <hr/> <p>Note</p> <p>If you receive the message DNS <code>\$_NOCOMMUNICATIONS</code>, Unable to communicate with any DECdns server during a set directory to new epoch or create replica command, you should increase the value for this parameter. It is CRITICAL that you increase this parameter on all servers that are in the replica set for the directory that had the problem. The timeout value should be the same on all servers in the replica set. If you fail to do this, any changes that you make will have no effect. However, if the time for long commands</p>

	starts to approach 2 hours this may indicate a hung link or a hung server.
<code>dns.dnsd.maximum_handlers_quota</code>	Maximum number of request handlers to allocate for request processing. The default value is 200. In most cases, the number of request handlers needed is approximately equal to the number of clerks connecting to the server.
<code>dns.dnsd.standby_handlers_quota</code>	Maximum number of request handlers to keep ready to process incoming requests. The default is 10.
<code>dns.dnsd.maximum_buffers_quota</code>	Maximum number of buffers available for request handlers from the request pool (rpool). The default is 200. Normally, the value for this parameter should be the same as the <code>maximum_handlers_quota</code> parameter.
<code>dns.dnsd.ta_conn_quota</code>	Maximum number of connections for front end operations (lookups, modify operations). The default is 200. Typically, the value for this parameter can be same or somewhat less than the <code>maximum_handlers_quota</code> and <code>maximum_buffers_quota</code> parameters. Both the <code>maximum_handlers_quota</code> and <code>maximum_buffers_quota</code> parameters may include an additional allowance for the back end operations. See additional requirements in the description of the <code>back_conn_quota</code> parameter.
<code>dns.dnsd.back_conn_quota</code>	Maximum number of connections for back end operations (skulks, other back ground activities). The default is 20. Note that the sum of these two connection quotas (specified by the <code>ta_conn_quota</code> and <code>back_conn_quota</code> parameters) should be below the values set (using NCL) for the maximum transport connections characteristic for either the <code>osi</code> transport or <code>nsp</code> entities. VSI recommends that the maximum transport connections characteristics be set so that the system never reaches the maximum number of connections specified. Increase the maximum transport connections

	<p>characteristics for NSP and OSI if required to meet this requirement. In addition, increase NET\$ACP process defaults.</p>
dns.dnsd.dormancy_evaluation_interval	<p>The time (in seconds) to keep resources used by a request available in pool so that they may be reused. The default is 60. Decreasing the value from the default may allow resources to be released earlier. However, decreasing it too much results in a delay in starting the processing of a new request.</p> <p>Consequently, if it is changed, it should be done very carefully.</p>
dns.dnsd.db_version_to_prune	<p>Sequence number of a checkpoint file. All dying replicas will be removed from this file. The default is 0 (turned off).</p> <p>The sequence number can be determined by typing out the clearinghouse version file (the file which has a file extension of .VERSION). Next, restart the server and then shut it down again. The server should write out a new checkpoint file with the dying replicas eliminated.</p> <p>Finally, remove the above line from the DNS .CONF file, and restart the server.</p> <p>Only one prune operation is allowed per server session.</p> <hr/> <p>Note</p> <p>If you choose to leave the line in the file, change the value to 0 (zero) to avoid accidental pruning.</p> <hr/> <p>To display the results of a prune operation in the DNS\$SERVER.LOG file, insert the db_checkpoint_info event into the SYS\$SYSDEVICE:[DNS \$SERVER]DNSD.EVENT file before beginning the prune operation.</p>

An example DNS .CONF file is shown below:

```
! all parameters in lowercase
dns.dnsd.acs_override: 1
dns.dnsd.node_verification: 0
!dns.dnsd.idle_conn_timeout: 500
!dns.dnsd.null_port_timeout: 5400
dns.dnsd.maximum_handlers_quota: 1000
```

```
dns.dnsd.standby_handlers_quota: 10
dns.dnsd.maximum_buffers_quota: 1000
dns.dnsd.ta_conn_quota: 600
!dns.dnsd.back_conn_quota: 100
dns.dnsd.dormancy_evaluation_interval: 30
!dns.dnsd.db_version_to_prune: 1236
```

Parameter lines can be commented out by placing an exclamation character (!) at the beginning of the line.

12.7. Solving Common Access Control Problems

This section contains information to help you solve access control problems involving the following DECdns operations:

- Viewing namespace information
- Creating a clearinghouse
- Creating a directory
- Deleting a directory
- Creating a replica
- Deleting a replica
- Modifying a directory's replica set
- Restoring access

12.7.1. Access Problems Viewing Namespace Information

The DECdns Control Program provides two basic display commands, `show` and `directory`, with which you can view namespace structure and contents. To use these commands, you must have read access to the name you want to display. If you try to display a name to which you do not have read access, an error message appears, indicating the requested name does not exist:

```
Requested name does not exist
```

This error can also be caused by any of the following conditions:

- The name you tried to access does not exist in the namespace.
- The name exists but is newly created and is not yet known to the clearinghouse with which you are communicating.
- The name you tried to access is being deleted.
- You mistyped the name.

If none of these conditions is true, ask your namespace administrator (or someone else who has sufficient access to the name you want to display) to verify that you have read access to the name. Administrators should check for the following when examining the access control set (ACS) associated with the name:

- If read access has been granted to the name through the use of an access control group, make sure the group flag is specified in the ACS.
- For directory names, check to see if the only access control entry (ACE) specifying the requesting principal is a default ACE. (Default ACEs grant access only to the future contents of a directory and not to the directory itself.) If this is the case, create another ACE on behalf of the principal that does not specify the default flag.

12.7.2. Access Problems Creating a Clearinghouse

In DECdns, you can create a clearinghouse in the following ways:

- When you configure a DECdns server in an existing namespace.
- When you relocate an existing functional clearinghouse on another node and use the `create dns server clearinghouse` command to re-create the clearinghouse at its new location.

To successfully create a clearinghouse and ensure that it is able to perform subsequent clearinghouse operations, you must have the following access rights and privileges:

- The account under which you are executing the clearinghouse creation needs write access to the directory in which you intend to name the clearinghouse.
- You must have the NET\$MANAGE rights identifier.
- The DNS\$Server principal on the server where you are creating the clearinghouse needs read, write, delete, and control access to the directory in which you intend to name the new clearinghouse. Specify the principal as `nodename.DNS$Server`, where *nodename* is the DECdns full name of the node on which you are creating the clearinghouse.
- The `system` account of the node needs control access to the directory in which you intend to name the new clearinghouse. Specify the principal as `nodename.system`
- If any replica of the directory in which you intend to name the new clearinghouse is stored on a VAX Distributed Name Service (DNS) Version 1 server (on a DECnet Phase IV node), you must create two additional ACEs that grant the same access described in the preceding bullet item but that specify DNS Version 1 principals (in the format `nodename::username`).

You must grant this access before you try to configure the server. Otherwise, the server creation may succeed, but the clearinghouse creation will fail and return one or both of the following error messages:

```
Insufficient rights to perform requested operation
```

```
Server process has insufficient access to clearinghouse
```

If either of these occur, use the `show directory access` commands to verify the rights currently granted on behalf of your principal name, the DNS\$Server principal, and the `root` or `system` accounts. If the required access is not in place, ask your namespace administrator (or

someone else who has the necessary rights and privileges) to grant the required access. After the appropriate ACEs are created, retry the clearinghouse creation.

12.7.3. Access Problems Creating a Directory

To successfully create a directory, you must have the following access rights:

- Write access to the parent directory of the directory you intend to create
- Write access to the clearinghouse in which you are naming the new directory

If you do not have these rights, the directory creation fails and returns the following error message:

```
Insufficient rights to perform requested operation
```

If this occurs, use the `show directory access` and `show clearinghouse access` commands to verify the rights currently granted on behalf of your principal name. If you do not have write access to both the parent directory and clearinghouse, ask your namespace administrator (or someone else who has control access to the parent directory and clearinghouse) to grant you the required access. After the appropriate ACEs are created, reenter your original `create directory` command.

Note

For the `create directory` command to execute successfully, the clearinghouse that stores the master replica of the new directory's parent directory must be available when you enter the command.

After you create a directory, enter the `show directory access` command to display the `DNS$ACS` attribute of the new directory. Make sure that the users and applications for whom the directory was created have the proper access. If the required access was not inherited from the access control set (ACS) of the new directory's parent directory, use the `add directory access` command to create the necessary access control entries (ACEs). See Chapter 5 for complete information on how to add access to a directory.

12.7.4. Access Problems Deleting a Directory

To delete a directory, you must have the following access rights:

- Read and delete access to the directory
- Write, delete, or control access to the directory's parent directory
- Write access to the clearinghouse that stores the master replica of the directory (or directories) you intend to delete

If you do not have these access rights, the directory deletion fails and returns the following error message:

```
Insufficient rights to perform requested operation
```

If this occurs, use the `show directory access` and `show clearinghouse access` commands to verify the rights currently granted on behalf of your principal name. If you do not have all the required access, ask your namespace administrator (or someone else who has control access to the directory, parent directory and clearinghouse that stores the directory's master replica) to

grant you the required access. After the appropriate ACEs are created, reenter your original `delete directory` command.

12.7.5. Access Problems Creating a Replica

To create a replica, you must have the following access rights:

- Control access to the directory you want to replicate
- Write access to the directory's parent directory
- Write access to the clearinghouse where you want to store the replica
- The `DNS$Server` principal on the server node (clearinghouse) where you intend to create the replica needs read, write, delete, and control access to the directory you want to replicate. The `DNS$Server` principal requires this access to successfully carry out updates and skulks of the directory.

If you do not have these access rights, the replica creation fails and returns one or both of the following error messages:

```
Insufficient rights to perform requested operation
```

```
Server process has insufficient access to clearinghouse
```

If this occurs, use the `show directory access` and `show clearinghouse access` commands to verify the rights currently granted on behalf of your principal name and the `DNS $Server` principal. If the required access is not in place, ask your namespace administrator (or someone else who has control access to the directory, parent directory and clearinghouse where you intend to store the new replica) to grant the required access. After the appropriate ACEs are created, initiate a skulk of the directory you want to replicate to make sure that the new access is applied to all existing replicas in the directory's replica set. Then, reenter your original `create replica` command.

12.7.6. Access Problems Deleting a Replica

To delete a replica, you must have the following access rights:

- Control access to the directory whose replica you want to delete
- Write access to the clearinghouse from which you are deleting the replica
- Write and delete access to the directory's parent directory

If you do not have these access rights, the replica deletion fails and returns the following error message:

```
Insufficient rights to perform requested operation
```

If this occurs, use the `show directory access` and `show clearinghouse access` commands to verify the rights currently granted on behalf of your principal name. If you do not have all the required access, ask your namespace administrator (or someone else who has control access to the directory, parent directory and the clearinghouse from which you want to delete the replica) to grant you the required access. After the appropriate ACEs are created, reenter your original `delete replica` command.

12.7.7. Access Problems Modifying a Directory's Replica Set

You can use the `set directory to new epoch` command to modify a directory's replica set. To use this command, you must have the following access:

- Read and control access to the directory
- Write access to each clearinghouse that stores a replica of the directory

If you do not have these access rights, the command fails and returns the following error message:

```
Insufficient rights to perform requested operation
```

If this occurs, use the `show directory access` and `show clearinghouse access` commands to verify the rights currently granted on behalf of your principal name. If you do not have all the required access, ask your namespace administrator (or someone else who has control access to the directory, parent directory and the clearinghouse from which you want to delete the replica) to grant you the required access. After the appropriate ACEs are created, reenter your original `set directory to new epoch` command.

Note

If the directory is replicated in both DNS Version 1 and DECdns Version 2 clearinghouses, make sure that both Version 1 and Version 2 ACEs exist on the directory and all of its contents before you try to set the new epoch. See Section 5.1.1 and Section 5.1.2 for information on how to specify Version 2 and Version 1 principals in ACEs. Appendix F summarizes interoperability considerations in an environment with both DNS Version 1 and DECdns Version 2.

12.7.8. Restoring Access to a Name

If all the access to a name is mistakenly deleted, you can use the DECdns diagnostic interface to restore the appropriate access to the name. The diagnostic interface allows you to override the normal restrictions preventing unauthorized modification of a name's access control set (ACS).

Note

You must perform the following procedure at the server that stores the master replica of the directory (or contents) to which you intend to restore access. You cannot restore access remotely.

Use the diagnostic interface *only* as directed.

To restore access, take the following steps:

1. Make sure you are logged in under the `system` account. Invoke the DECdns diagnostic interface by entering the following command:

```
$ run sys$system:dns$diag
```

The `diag>` prompt appears.

2. At the `diag>` prompt, enter the following command:

```
diag> enable acs_override
```

3. Type `q` to exit the diagnostic interface and return to the system prompt.
4. Invoke the DECdns Control Program and use the `add access` commands to restore minimum required access. See Chapter 5 for information on granting access.
5. After you restore sufficient access, exit the DECdns Control Program and return to the system prompt.
6. Repeat step 1 to invoke the diagnostic interface again. At the `diag>` prompt, enter the following command to disable the access override:

```
diag> disable acs_override
```

7. Type `q` to exit the diagnostic interface and return to the system prompt.

With minimum required access restored, invoke the DECdns Control Program again to grant additional access if necessary.

12.8. Handling Clearinghouse Creation Failures

You create most clearinghouses with the DECdns configuration program when you configure new DECdns servers. You also create (or, more specifically "re-create") a clearinghouse when you relocate an existing clearinghouse on another server system. In most cases, if you name a new clearinghouse in the root directory and grant the appropriate access before you create the clearinghouse, the creation will succeed. If, however, you are repeatedly unable to create a clearinghouse, make sure you meet all the following conditions before you try to create the clearinghouse again:

1. Check that the `DNS$Server` principal and the root principals on the server have the required access to the directory in which you intend to name the clearinghouse (usually the namespace's root directory). See Section 12.8.1 for information on how to grant the necessary access.
2. If you are trying to name the clearinghouse in a directory other than the root directory, verify that the directory allows the storage of clearinghouse object entries (`DNS$InCHName=true`). See Section 12.8.2.
3. Verify that the system on which you are trying to create the clearinghouse has been registered in the namespace through the use of the DECnet-Plus node registration tool `decnet_register`.

If a replica of the directory in which you are trying to name the new clearinghouse is stored on a DNS Version 1 server (on a Phase IV node), you must also verify that the name of the DECnet Phase V server on which you are creating the clearinghouse is defined in the Phase IV server's node database and that its address in the node database matches the DECnet Phase V server's node address in the namespace. See Section 12.8.3.

4. Make sure all clearinghouses that store a replica of the directory in which you are trying to name the new clearinghouse are running and are available. See Section 12.8.4.

12.8.1. Granting Required Access

Before you create a clearinghouse, grant the following DECdns access to the directory in which you intend to name the new clearinghouse (usually the root directory of the namespace):

- For the `DNS$Server` principal on the server, grant read, write, delete, and control access to the directory in which you intend to name the clearinghouse. Specify the principal as `nodename.DNS$Server`, where `nodename` is the full DECdns name of the node on which the server is running.
- For the `system` account on the server, grant control access to the directory in which you intend to name the clearinghouse. Specify the principal as `nodename.root` or `nodename.system`.
- If a replica of the directory in which you intend to name the new clearinghouse is stored on a DNS Version 1 server, you must create two additional ACEs that grant the same access as described above (for the `DNS$Server` principal, and for the `system` principals (in the format `nodename::username`)). Thus, four ACEs (two in Version 2 format and two in Version 1 format) are required. Appendix F summarizes interoperability considerations in an environment with both DNS Version 1 and DECdns Version 2.

The `add directory access` commands that you use to grant this access must be entered from an account that has control access to the directory in which you intend to name the new clearinghouse. For more information on specifying principals and granting DECdns access, see Chapter 5.

Example

The following two example commands grant the required access for the `DNS$Server` and `system` principals to the root directory of the namespace in which a new clearinghouse on node `.mynode` will be created. You must enter both commands from an account that has control access to the root directory of the namespace.

1. The following command grants read, write, delete, and control access to the root directory (`.`) for the `DNS$Server` principal on node `.mynode`.

```
dns> add directory . access .mynode.dns$server for r,w,d,c
```

2. The following command grants control access to the root directory for the `system` account on node `.mynode`.

```
dns> add directory . access .mynode.system for c
```

If a replica of the directory in which you are naming the clearinghouse (in this case, the root directory) is stored on a DNS Version 1 server, you would enter the following two additional commands:

```
dns> add directory . access mynode::dns$server for r,w,d,c
dns> add directory . access mynode::system for c
```

12.8.2. Allowing a Directory to Store Clearinghouse Object Entries

Before you try to name a clearinghouse in any directory below the root, make sure that the directory allows the storage of clearinghouse object entries (even if you do not intend to store clearinghouse object entries in the directory). If you are trying to name a clearinghouse in the root directory, this task is not required.

You control whether a directory can store clearinghouse object entries by modifying the value of its `DNS$InCHName` attribute. Except for the root directory (whose `DNS$InCHName` attribute is always set to true), this directory attribute can have a value of true or false. By default, the `DNS$InCHName` attribute of all directories that you create under the root is set to false. To name a clearinghouse (that is, to create a clearinghouse object entry) in a lower-level directory, you must reset the value of the directory's `DNS$InCHName` attribute to true.

Before You Modify a Directory's DNS\$InCHName Attribute

Before you try to set a directory's `DNS$InCHName` attribute to true, make sure the directory's parent directory already has its own `DNS$InCHName` attribute set to true.

To Set a Directory's DNS\$InCHName Attribute to True

To modify the value of a directory's `DNS$InCHName` attribute, you must have control access to the directory.

Use the `set directory` command to set the value of a directory's `DNS$InCHName` attribute from false to true.

Example

The following command sets the `DNS$InCHName` attribute of the `.admin` directory to true:

```
dns> set directory .admin dns$inchname=true
```

12.8.3. Verifying Server Node Registration and Address Information

The system on which you intend to create a clearinghouse must be registered in the namespace for clearinghouse creation to succeed. You can use the DECnet-Plus node registration tool (`decnet_register`) to display node information and verify that a node is properly registered in the namespace.

For complete information on how to use the node registration tool for this purpose, see the *VSI DECnet-Plus for OpenVMS Network Management Guide*.

DECnet Phase IV Interoperability Considerations

If a replica of the directory in which you are trying to name the clearinghouse is stored on a DNS Version 1 server (on an OpenVMS Phase IV node), you must complete two additional tasks. For each Phase IV node that stores such a replica, use the Phase IV Network Control Program (NCP) `show node nodename` command to verify the following conditions:

1. Verify that the name of the DECnet Phase V node on which you are trying to create the clearinghouse is defined in the Phase IV node's local node database.
2. Verify that the address of the DECnet Phase V node (as stored in the Phase IV node's local node database) matches the DECnet Phase V address of the DECnet Phase V node.

The DECnet Phase V server on which you create the clearinghouse must be represented in the Phase IV node database with a Phase IV compatible address (for example, 4.20).

12.8.4. Verifying Availability and Connectivity to Clearinghouses

When you create a clearinghouse, a replica of the directory in which the clearinghouse is named is also created and stored in the new clearinghouse as its initial replica. The replica creation succeeds only if all the clearinghouses that store a replica of the directory containing the new clearinghouse name are running and reachable when you try to configure the new server, because DECdns skulks a directory when it creates a new replica.

For example, if you intend to name a new clearinghouse in the root directory, then all clearinghouses that store a replica of the root directory must be running (in the on state) and reachable when you try to create the clearinghouse.

To verify that these conditions are satisfied, take the following steps:

1. For the directory in which you intend to name the new clearinghouse (usually the root), use the `show directory` command and specify the `DNS$Replicas` attribute to display the name of every clearinghouse that stores a replica of the directory. For example, the following command displays a list of all clearinghouses that store a replica of the root directory:

```
dns> show directory . DNS$Replicas
```

2. With this information, use the `show replica` command to verify that you can receive a response to a look up request of any attribute associated with the replica at each of the clearinghouses you found in step 1. If you receive a response to the `show replica` command, you can be sure that the clearinghouse in which it is stored is running and available. (Remember that you must have read access to the clearinghouse for the `show replica` command to succeed.) For example, the following command displays the value of the `DNS$CTS` attribute associated with the replica of the root directory stored at clearinghouse `.Paris_CH`:

```
dns> show replica . at clearinghouse .paris_ch dns$cts
```

3. Alternatively, if you know the node names of each of the clearinghouses you found in step 1, you could use the `show dns server clearinghouse` command and specify the `state` attribute to make sure each of the clearinghouses is running and available. For example, the following command displays the current state of the clearinghouse on node `.vega`.

```
dns> show node .vega dns server clearinghouse state
```

Note

All DECdns operations that involve the modification of a directory's replica set require every clearinghouse that stores a replica of the directory is running and reachable when you attempt the operation. This requirement applies to the following DECdns commands:

- `create replica`
- `delete replica`
- `create dns server clearinghouse`
- `delete dns server clearinghouse`
- `set directory to new epoch`

12.9. Restoring a Corrupted Clearinghouse

If you see an error that indicates data corruption at a clearinghouse, or if the DECdns server crashes and does not restart, the indicated clearinghouse may be corrupted. A clearinghouse database can become corrupt for a variety of reasons. The most common reasons are:

- One or more of the clearinghouse's database files is missing, usually because of accidental deletion or removal from its default location on disk.

- Individual entries within the database files are missing, incomplete, or out of sequence.
- The TLOG files on the system keep growing and fail to checkpoint. A TLOG file is a transaction log file maintained on disk. All changes made to the running DECdns server database (held in memory) are recorded in the TLOG file. A TLOG file is typically 201 blocks in size when empty. Whenever the file is larger than 201 blocks, the memory copy of the database contains changes that are not in the disk copy of the checkpoint file. Once a new copy of the checkpoint file has been written to disk, the version file will be updated to a new sequence and the TLOG file emptied.

To determine the cause, check the `DNS$SERVER.LOG` file for clues.

To restore a corrupted clearinghouse, take the following steps:

1. Verify the corruption.

First, disable the clearinghouse by entering the `disable dns server clearinghouse` command. With the clearinghouse in the off state, verify that the clearinghouse database files exist. DECdns Version 2 clearinghouse database files reside in the `SYS $SYSDEVICE:[DNS$SERVER]` directory (or in the alternative directory contained in `SYS $MANAGER:DNS_FILES.TXT`). (If the clearinghouse was created with DNS Version 1 software and later converted to DECdns Version 2 format, the clearinghouse files reside in the `SYS $SYSROOT:[DNS$SERVER]` account.)

Clearinghouse files are named in the following format:

- *clearinghouse-name.checkpointnnnnnnnnnn*
- *clearinghouse-name.tlognnnnnnnnnn*
- *clearinghouse-name.version*

If any or all of these files are missing, the clearinghouse cannot be restored. Delete any remaining files and go to step 2.

If all the database files exist, turn on the clearinghouse by using the `enable dns server clearinghouse` command. If service is not restored, delete all database files and go to step 2.

2. Gather directory and replica-type information.

- Use the `show object` command to examine the `DNS$ChDirectories` attribute of the corrupted clearinghouse's associated clearinghouse object entry. This command displays the names of all the directories that stored replicas in the corrupted clearinghouse. For example, the following command displays the `DNS$ChDirectories` attribute values for a clearinghouse object entry named `.NY1_CH`.

```
dns> show object .ny1_ch dns$chdirectories
```

```

          SHOW
CLEARINGHOUSE IAF:.NY1_CH
          AT 17-JUL-2018:09:11:00

DNS$ChDirectories = :
  CTS of Directory = 2018-03-11-05:35:16.16000000/aa-00-05-00-de-09
  Name of directory = .

DNS$ChDirectories = :
```

```
CTS of Directory = 2018-06-15-15:50:44.18000000/aa-00-04-00-de-11
Name of directory = .sales
```

```
DNS$ChDirectories = :
CTS of Directory = 2018-07-21-14:01:21.18000000/aa-00-05-00-de-11
Name of directory = .eng
```

- b. For each directory you find in step 2a, use the `show directory` command and specify the `DNS$Replicas` attribute to determine the replica type (master or read-only) of the replica that each directory stored in the corrupted clearinghouse. For example, the following command displays the `DNS$Replicas` attribute values for the `.sales` directory found by the example command in step 2a.

```
dns> show directory .sales dns$replicas

          SHOW
          DIRECTORY   IAF:.sales
          AT          09-APR-2018:16:08:25
DNS$Replicas (set) = :

Clearinghouse's DNS$CTS = 2018-03-22-14:39:34.58/aa-00-04-00-de-11
  Tower 1 CTS          = 2018-04-09-20:08:25.835/08-00-2b-0d-c0-9d
    Floor 1            = 01 2c      (null)
    Floor 2            = 02          00 2c      ncacn_dnet_nsp
    Floor 3            = 04          (null)
    Floor 4            = 06          49 00 17 aa 00 04 00 22 dc 20
  Replica type        = master

Clearinghouse's Name   = IAF:.Chicago1_CH
DNS$Replicas (set)    = :

Clearinghouse's DNS$CTS = 2018-07-30-20:32:42.82/aa-00-04-00-de-11
  Tower 1 CTS          = 2018-04-09-20:08:25.835/08-00-2b-0d-c0-9d
    Floor 1            = 01 2c      (null)
    Floor 2            = 02          00 2c      ncacn_dnet_nsp
    Floor 3            = 04          (null)
    Floor 4            = 06          49 00 13 aa 00 04 00 7e 52 20
  Replica type        = readonly
Clearinghouse's Name   = IAF:.NY1_CH
```

Make a note of this directory and replica-type information. You will need it later (in step 4) to rebuild the replica sets of the directories that were stored in the clearinghouse and to repopulate the new clearinghouse that you create to replace the corrupted clearinghouse.

3. Delete the associated clearinghouse object entry.

After you gather the replica-type information, use the `delete object` command to delete the corrupted clearinghouse's associated clearinghouse object entry. This prevents further lookup requests to the corrupted clearinghouse.

4. Rebuild the replica sets of the directories.

With the information you gathered in step 2, use the `set directory to new epoch` command to rebuild the replica set of each directory that stored a replica in the corrupted clearinghouse. Use the `exclude` argument of the command to exclude the replica that was stored in the corrupted clearinghouse from each directory's replica set. Until you perform this step, skulks of these directories will fail.

Handling Master Replicas

If a replica stored on the corrupted clearinghouse was a master replica, and if other read-only replicas of the directory exist, you must designate one of those read-only replicas as the directory's new master replica.

You can simultaneously omit a replica and redesignate a new master replica of a directory with the `set directory to new epoch` command. See Chapter 9 for information on how to use the `set directory to new epoch` command to perform these tasks.

Handling Orphaned Child Directories

If a master replica stored on the corrupted clearinghouse was the only replica in that directory's replica set, the directory is lost and cannot be retrieved. Furthermore, any child directory that exists below a lost directory are *orphaned* (cut off from the directories that exist above it in the namespace hierarchy). Although the directory and the information it contained are lost, you can reconnect an orphaned child directory by creating a new directory in place of the lost directory and then creating a new child pointer to the orphaned child directory.

Note

If none of the replicas stored on the corrupted clearinghouse were master replicas, you can skip this step and go to step 5.

To reconnect an orphaned directory, perform the following steps:

- a. For each orphaned directory, use the `delete child` command to delete (from the lost directory's parent directory) the child pointer to the lost directory.
- b. Use the `create directory` command to create a new directory of the same name as the lost directory.
- c. For each orphaned directory, follow the procedure described in Section 12.10 to create new child pointers to those directories. After you create the necessary child pointers, go to step 5 of this procedure.

5. Create a new clearinghouse.

Use the `create dns server clearinghouse` command to create a new clearinghouse of the same name as the corrupted clearinghouse you are replacing. See Chapter 6 for information on how to create a clearinghouse with the `create dns server clearinghouse` command.

6. Repopulate the new clearinghouse with the contents of the corrupted clearinghouse.

With the replica-type information that you gathered in step 2, use the `create replica` command to populate the new clearinghouse with replicas (of the same replica types) of the same directories that the corrupted clearinghouse originally contained. See Chapter 7 for information on how to use the `create replica` command.

12.10. Restoring a Deleted Child Pointer

Occasionally, you may need to restore a child pointer that has been accidentally deleted. Child pointers contain the information that DECdns uses to keep track of the clearinghouses where each

replica of a child directory's replica set is stored. If a child pointer is deleted, the parent directory and child directory are cut off from each other. Name lookups downward from this point through the namespace hierarchy fail because, without the child pointer, DECdns cannot determine where to find the information for which it is searching.

To restore a deleted child pointer, use the following procedure:

1. Before you try to restore a deleted child pointer, make sure you have the following access rights:
 - Write access to the parent directory of the orphaned child directory
 - Read access to the orphaned child directory
2. Because the child pointer is missing, DECdns cannot determine where any replicas of the orphaned directory are stored. Before you use the `create child` command to restore the child pointer, you must make sure the create child operation will be directed to a clearinghouse that stores a replica of the orphaned child directory. If this information is not readily available, use the `show replica` command and specify the names of clearinghouses that you suspect might contain a replica of the orphaned directory. Continue issuing this command until you find a clearinghouse that stores a replica of the orphaned directory.
3. After you identify a clearinghouse that stores a replica of the orphaned directory, use the `set dnscp preferred clearinghouse` command to ensure that the `create child` command you enter in the next step is directed to the clearinghouse that stores a replica of the orphaned directory.
4. Enter the `create child` command and specify the clearinghouse you identified in step 3 to restore the child pointer.

12.11. Restoring a Missing Clearinghouse Object Entry

Every time a clearinghouse is enabled, it tries to contact its corresponding clearinghouse object entry to verify that the clearinghouse is still properly registered in the namespace. If a clearinghouse object entry is mistakenly deleted, requesting clerks may not be able to access the associated clearinghouse.

To restore a lost clearinghouse object entry, perform the following steps:

1. Verify that the clearinghouse object entry was deleted.
2. Use the `create object` command to create a new clearinghouse object entry. Make sure you specify the following values:
 - a. Specify the same name that was assigned to the deleted clearinghouse object entry.
 - b. Set the `class` attribute to `DNS$Clearinghouse`.
 - c. Set the `class version` attribute to `1.0`.

For example, the following command creates a clearinghouse object entry named `.Paris1_CH`.

```
dns> create object .paris1_ch class=dns$clearinghouse, class -  
_> version=1.0
```

3. Make sure that the `DNS$Server` principal on the server where the associated clearinghouse resides has full access (read, write, delete, test, and control) to the restored clearinghouse object entry.

Normal service will be restored when the clerk (on the server system where the associated clearinghouse resides) detects that the `DNS$CTS` attribute of the clearinghouse object entry has changed. This usually occurs within one hour. Remember, however, that a record of the original clearinghouse object entry may be temporarily retained in the caches of other clerks that regularly use the associated clearinghouse.

12.12. Handling Node Verification Failures

DECdns, together with DECnet, performs a special security check called node verification on all operations that could modify information in the namespace. Whenever a clerk connects to a DECdns Version 2 server, DECnet passes the clerk's request to the server and includes the principal (`nodename.username`) associated with the request.

For read operations (`show` and `directory` commands), the server trusts that the node name provided by DECnet is a valid node name and then performs the usual access control checks using that name. However, for write and control operations (such as with the `set`, `create`, and `delete` commands) the server must first authenticate the node name. That is, the server must authenticate the requesting node by requesting DECnet to verify the node name.

If DECnet node verification fails, the server returns the following error message:

```
Requesting principal could not be authenticated to the clearinghouse
```

For node verification to succeed, the following conditions must be satisfied:

1. A node object entry representing the requesting clerk must exist and be properly registered in the namespace.

You can use the DECnet-Plus node registration tool (`decnet_register`) to display node information and verify that the clerk node has been properly registered in the namespace. See the *VSI DECnet-Plus for OpenVMS Network Management Guide* for complete information on how to use the node registration tool for this purpose.

2. The `DNS$Server` principal (`nodename.dns$server`) on the server storing the master replica of the directory (or contents) you are trying to modify must have read access to the node object entry that represents the requesting clerk in the namespace. Node object entries are typically created with world read access. Unless this access has been changed, the `DNS$Server` principal of every server in the namespace should have sufficient access to the node object entry.

See Section 12.1.4.3 for instructions on how to determine the node name of the server (clearinghouse) that stores the master replica of a directory.

3. At least one clearinghouse that stores a replica of the directory containing the node object entry must be running and available when the clerk makes its request. If the server cannot communicate with such a clearinghouse, node verification fails due to insufficient information.
4. Assuming that the preceding conditions are satisfied, the `DNA$Towers` attribute associated (registered) with the node object entry (which holds address information for the node) must match the address information associated with the DECnet Phase IV or Phase V connection. If the towers (addresses) match, the requesting node is verified. If the towers do not match, the verification

fails. For complete information on how to use the node registration tool to edit a node address, see the *VSI DECnet-Plus for OpenVMS Network Management Guide*.

Note

Node verification can occasionally fail in response to a request to read a name. Permission to perform a read operation is granted if the requesting principal has read access to the name itself, or control access to the directory in which the named is stored. If the requesting principal has read access to the name, permission to perform the read operation is granted based on that access. However, if the requesting principal does not have read access, DECdns, before denying access, examines the ACS of the parent directory of the name, to see if the principal has control access to that directory. This second check for control access on the parent directory triggers the node verification process, which may succeed or fail for the reasons described previously in this section.

Version 1 servers (running Version 1.1 of the VAX Distributed Name Service software) do not perform node verification and grant or deny permission to modify a name based only on whether the requesting principal has sufficient access to the master replica of the directory (or the name therein) to be modified. If your namespace contains both Version 1 and Version 2 servers (running DECdns Version 2.0), you may experience access or node registration problems if you move a master replica of a directory (through the use of the `set directory to new epoch` command) from a Version 1 server to a Version 2 server on which node verification is enforced. Appendix F summarizes interoperability considerations in an environment with both DNS Version 1 and DECdns Version 2.

Overriding Node Verification for Operations on Individual Names

You can override node verification on individual names by creating an ACE in the ACS of the name that grants appropriate access to all potential users of your namespace, regardless of the node with which their user accounts are associated. You express the idea of all users of the namespace in the principal of the ACE by specifying the namespace nickname followed by `. * . . .` as the user name portion of the ACE. For example, the following `add access` command creates an ACE that grants, to all users of the IAF namespace, write access to the `.eng` directory:

```
dns> add directory .eng access IAF:.*... for r,w
```

Once this ACE is created, all users of the IAF namespace can perform write operations on the `.eng` directory, even if the node name with which their individual user accounts are associated cannot be verified by DECnet.

Enabling and Disabling Node Verification on Individual Servers

If you do not always require the added security that node verification provides, you can use the DECdns diagnostic interface to locally disable node verification on individual server nodes. VSI recommends that you do not permanently disable node verification on all servers. This creates a serious security risk.

Note

To disable node verification, you must be logged into the server whose node verification function you want to disable. You cannot disable node verification remotely.

To disable node verification on a server, take the following steps:

1. While logged in under the `system` account, invoke the DECdns diagnostic interface by entering the following command at the system prompt:

```
$ run sys$system:dns$diag
```

2. At the `diag>` prompt, enter the following command to turn off node verification on the local server:

```
diag> disable node_verification
```

Node verification will remain disabled until the server is restarted or until you enter the following command to reenable it manually:

```
diag> enable node_verification
```

3. To exit the diagnostic interface, type `q`.

Note

Use the diagnostic interface *only* as directed.

You can also use the `dns.dnsd.node_verification` parameter in the `DNS.CONF` file. See Section 12.6 for more information.

12.13. Breaking Soft Link Loops and Group Loops

A soft link loop occurs when a soft link (in a series of two or more soft links) points back to itself. In its simplest form, a soft link loop involves only two soft links whose destination names (DNS `$LinkTarget` attributes) specify each other. For example, suppose two soft links (`.link1` and `.link2`) exist in the root directory of a namespace. A soft link loop between these two soft links exists if the destination name of `.link1` points to `.link2` and the destination name of `.link2` points to `.link1`. Soft link loops can involve more than two soft links.

A group loop occurs when two or more groups include each other as group members.

When DECdns detects a possible soft link loop or group loop, the following message is displayed:

```
Possible cycle detected
```

To identify the soft links in a soft link loop, take the following steps:

1. Enter the `show link` command and specify the `DNS$LinkTarget` attribute of the soft link specified in the error message.
2. Enter the `show link` command and specify the `DNS$LinkTarget` attribute of the soft link you found in step 1.
3. Continue this process until you find the soft link whose `DNS$LinkTarget` attribute specifies a soft link earlier in the series of soft links.

To break a soft link loop, use the `delete link` command to delete the soft link that is causing the loop, or use the `set link` command to redirect one (or more) of the soft links to different destination names.

To identify the groups in a group loop, take the following steps:

1. Enter the `show group` command and specify the `DNS$Members` attribute to display the members of the group specified in the error message.
2. For each group member that is itself a group, repeat step 1 until you find the group (or groups) that specify each other as members.

To break a group loop, use the `remove member` command to remove from membership the particular group (or groups) causing the loop.

12.14. Eliminating Ambiguous Namespace Nicknames

The DECdns advertiser (`DNS$ADVER`) broadcasts messages, called server advertisement messages, to the network so that clerks can determine the location and availability of DECdns servers. A clerk detects an ambiguous nickname when it receives a server advertisement message containing a nickname that matches the nickname of a known namespace in its cache but has a different namespace creation timestamp (`NSCTS`) value than the `NSCTS` value of the cached namespace. After receiving the message, the clerk detects that two entries exist in its list of known namespaces that use the same nickname but have different `NSCTS` values. The clerk considers the nicknames in both entries to be ambiguous. The next time you enter a command from the clerk that specifies either nickname, the clerk returns the following error message:

```
Specified nickname is ambiguous
```

Ambiguous nicknames can be caused in the following ways:

- A namespace administrator creates a namespace on a server that is not currently connected to the local area network (LAN) but assigns it a nickname that matches the nickname of a namespace already in use on the LAN. The server is subsequently connected to the LAN and advertises the duplicate nickname.
- A namespace administrator creates a namespace that advertises its existence to all clerks on the LAN. Then, for some reason, the administrator deletes the namespace and creates another namespace using the same nickname assigned to the deleted namespace. In this case, clerks on the LAN have known namespace entries for two namespaces using the same nickname.
- A namespace administrator on a system running VAX Distributed Name Service (DNS) software on your LAN creates a namespace and assigns a nickname matching that of a namespace already in use on your LAN. (DNS Version 1 clerk software does not prevent users from assigning the same nickname to different namespaces.)
- A user configures a clerk on a LAN to communicate with a server in a namespace that exists across a wide area network (WAN) link. The nickname of the namespace across the WAN link matches the nickname of a namespace already in use on the LAN.

Each DECdns clerk maintains a cache of known namespaces to keep track of the namespaces with which it communicates. You can specify a known namespace by using any of the following attributes:

- **NSCTS** — The value of the `NSCTS` attribute is assigned automatically when the namespace is created. A namespace's `NSCTS` cannot be modified and is guaranteed to be unique.
- **Nickname** — A namespace's `nickname` attribute is a human-readable name assigned by the creator and coupled with the `NSCTS` attribute during namespace creation. After it is assigned, a namespace nickname cannot be modified.

- **Name** — A namespace's name attribute is generated by the clerk when it receives an advertisement message for the namespace. The value of a namespace's name attribute is usually the same as its nickname attribute, whose value you assign during namespace creation. If a nickname in an advertisement message is ambiguous, the clerk modifies the namespace's corresponding name attribute by appending an underscore and a number (`_n`) to the Name. Remember that, because each clerk maintains its own list of known namespaces, and because all clerks on the LAN may not receive advertisements in the same sequence, the value of a namespace's name attribute can vary from one clerk to another. (You can use the `set dns clerk known namespace` command to modify the value of a namespace's name attribute. See Chapter 11 for more information on this command.)

12.14.1. Locating the Source of an Ambiguous Nickname

If a clerk detects that a requested operation involves an ambiguous nickname, for example, after an attempt to access a name in the nondefault namespace nicknamed `abc`, you must locate the source of the ambiguous nicknames. The following command displays the NSCTS and name attributes for all namespaces with the nickname `abc`.

```
dns> show dns clerk known namespace *, with nickname=abc
Node 0 DNS Clerk Known Namespace 08-00-2B-0D-C0-9D-CD-3B-C6-16-EC-3B-94-00
```

```
AT 2018-02-07-10:38:23.387-05:00I0.189
```

Identifiers

```
NSCTS = 08-00-2B-0D-C0-9D-CD-3B-C6-16-EC-3B-94-00
```

```
Name = abc
```

```
Node 0 DNS Clerk Known Namespace 08-00-2B-0D-C0-9D-19-6B-56-B9-8C-3D-94-00
```

```
AT 2018-02-07-10:38:23.567-05:00I0.189
```

Identifiers

```
NSCTS = 08-00-2B-0D-C0-9D-19-6B-56-B9-8C-3D-94-00
```

```
Name = abc_1
```

The output of this command shows that the nickname `abc` was given to two different namespaces whose NSCTS values are `08-00-2B-0D-C0-9D-CD-3B-B6-16-EC-3B-94-00` and `08-00-2B-0D-C0-9D-19-6B-56-B9-8C-3D-94-00`. Because of this ambiguity, the clerk on this system appended the suffix `_1` to the name attribute of the namespace uniquely identified by the latter NSCTS value.

If the clerk receives advertisements from servers associated with other name-spaces in use on the LAN that are also using the `abc` nickname, the clerk will detect these additional ambiguities and append suffixes incrementally (`_2`, `_3`, and so on) to the name attributes of these namespaces.

12.14.2. Eliminating an Ambiguous Nickname

To permanently eliminate an ambiguous nickname, perform the following tasks:

1. Eliminate all sources of ambiguous advertisements on your LAN that are associated with the namespace or namespaces you intend to eliminate.
 - a. Locate all the servers on the LAN that are advertising the namespaces with the ambiguous nickname you want to eliminate.
 - b. On the server where each clearinghouse resides, use the `clear dns server clearinghouse` command to delete the clearinghouse associated with the ambiguous nickname from the server's list of clearinghouses it needs to automatically enable during its startup process. See Chapter 11 for information on how to use the `clear dns server clearinghouse` command.
 - c. Delete or relocate the clearinghouse database files from each affected server system. If you decide to relocate the clearinghouse, you must copy the database files to an off-LAN server. See Chapter 9 for information on how to relocate a clearinghouse.
 - d. When a DECdns clerk starts the `NET$DNS_CLERK_STARTUP.NCL` file executes. This file may contain an NSCTS of a name server that no longer exists on the LAN, in which case the clerk will not be able to communicate with a name server. The clerk could be getting the incorrect NSCTS from this file. Use option 1 of the DECdns configuration program to create a new file with the correct NSCTS (see Section 10.2).
2. On each clerk on the LAN, use the `delete dns clerk known namespace` command to eliminate the clerks' knowledge of the ambiguous nickname. You can use the namespace's name or NSCTS attribute in the command to specify the correct namespace.

For example, either of the following commands deletes (from the local clerk's list of known namespaces) the ambiguous nickname associated with the namespace whose `name` attribute is `abc_1` and whose NSCTS value is `08-00-2B-0D-C0-9D-19-6B-56-B9-8C-3D-94-00`.

```
dns> delete dns clerk known namespace abc_1

dns> delete dns clerk known namespace -
_> 08-00-2B-0D-C0-9D-19-6B-56-B9-8C-3D-94-00
```

12.15. Fixing Clock Synchronization Errors

The error message `Distributed update contained an invalid timestamp` may indicate a clock synchronization problem. Verify that DECdts is running and is correctly synchronizing all servers listed in the message text. This error does not necessarily indicate that clocks are not synchronized. Check the `SYS$MANAGER:DNS$SERVER.LOG` file for additional information about this error.

A clock synchronization problem usually does not require immediate attention, but you should have it fixed, because it can prevent replicas from receiving updates. Consult your VSI support representative.

If the server is run on a system that has the system time improperly set in the future, the server will store information in the database with a timestamp set in the future. The server rejects updates with timestamps more than 4 minutes into the future. You will see server messages when that happens. If you believe a server has this problem, first correct the time. If the error persists for more than 48 hours after the clocks have been corrected, contact your VSI support representative for help on correcting the problem. See the *VSI DECnet-Plus for OpenVMS DECdts Management* for information on clock synchronization.

12.16. Handling Clerk and Server Software Errors

When a DECdns clerk or server encounters an internal problem, the following error messages may be displayed:

```
Software error detected in clerk
```

```
Software error detected in server
```

These errors may indicate a serious problem in the clerk or server running on the system that receives the message. However, if DECdns service is not interrupted, and even if the error recurs, you should wait at least 24 hours before taking any action. For a server, the 24-hour waiting period allows sufficient time for DECdns to complete skulks of all the directories stored in the server's clearinghouse. Often, the skulking process solves the problem causing the error.

If, after 24 hours, the error messages continue to occur, or if DECdns service is interrupted, contact your VSI support representative.

12.17. Using Tracing Facilities

This section explains how to use trace facilities to help ascertain the cause of DECdns-related problems. You can trace the advertiser, clerk, server, and DECnet to record errors and help isolate the source of a problem.

12.17.1. Tracing the Advertiser

To trace the advertiser, do the following:

1. Edit `SY$STARTUP:DNS$CLERK_STARTUP.COM`, removing the exclamation point (!) from the following line:

```
$! Define/system DNS$_ADVER_TRACE 65535
```

2. Shut down the clerk.
3. Stop the `DNS$ADVER` process.
4. Restart the clerk (using `SY$STARTUP:DNS$CLERK_STARTUP.COM`).

When you restart the clerk, information will be logged to the file `SY$MANAGER:DNS$ADVER_ERROR.LOG`.

12.17.2. Tracing the Clerk

You can trace all events or only protocol-related activity.

Tracing All Clerk-Related Events

To trace all events in the system service, use the following command:

```
$ @sys$startup:dns$clerk_startup "DEBUG" "8191"
```

This creates a file called `DNS$CLERK.LOG` in `SYS$MANAGER:.` When you specify 8191, all events will be logged. Inevitably, however, some internal buffer will be overrun, causing some events to be dropped. If you display the `SYS$STARTUP:DNS$CLERK_STARTUP.COM` file, you will see individual event types described for each of the bits in this mask. If you already know what you want to observe, trace only a subset of all the events. For example, to look at arguments, service, and tree walk information, enter the following command:

```
$ @sys$startup.dns$clerk_startup "DEBUG" "ARGS" "SERVICE" "TREEWALK"
```

To turn logging off, enter the following command:

```
$ @sys$startup:dns$clerk_startup "DEBUG" "0"
```

For tracing on the clerk, you can look in `SYS$STARTUP:DNS$CLERK_STARTUP.COM` for the list of different trace points available (in comments).

If the clerk is consuming a large amount of CPU or writing excessive data to the `DNS$CHFAIL.LOG`, you can raise the priority of the `DNS$ADVER` process to 8. This increases the throughput of the advertiser. (The advertiser writes to the debug logs; in contrast, the clerk runs in kernel mode and does not write information directly to the disk.)

Tracing Protocol Activity

To activate tracing of clerk-related protocol activity, enter the following command at the system prompt:

```
@sys$startup:dns$clerk_startup debug protocol
```

Run your DECdns application. You should see a file named `SYS$MANAGER:DNS$CLERK.TRACE`.

Turn off tracing by entering the following command:

```
@sys$startup:dns$clerk_startup "DEBUG" "0"
```

To convert the trace file into readable form, enter the following command:

```
$ mcr dns$analyze
```

This creates file `DNS$CLIENT.ANA` in your current directory.

12.17.3. Tracing the Server

To trace events on the DECdns server, use the `DNS$DIAG` tool *only as directed*:

```
$ MCR DNS$DIAG
diag> set events allon
diag> mark begin test ❶
```

❶ This writes the string "begin test" into the log.

To have the server flush the latest trace information to the log file, use the following command sequence:

```
$ mcr dns$diag
diag> flush log
```

These commands write additional information into the `DNS$SERVER.LOG` file.

Note

VSI recommends using this diagnostic tool only as directed, unless you have in-depth understanding of this tool and of the consequences of the commands you want to use. Consult your VSI software support personnel for more assistance.

To turn logging off on the server, enter the following commands:

```
$ mcr dns$diag
diag> set events normal
diag>mark end test
```

To have the server log information during startup, create the file `SYS$SYSDEVICE:[DNS $SERVER]DNSD.EVENTS` and enter a single asterisk (*) in the file. Then restart the server.

12.17.4. Tracing DECnet

As mentioned earlier, problems that seem related to DECdns often actually originate elsewhere. Most often, general lookup problems are related to DECnet. Check that the basic DECnet operations work. First, execute commands that cause DECnet to take actions not using DECdns.

Next, execute commands using node addresses instead of node names. If a command that works with a node name does not work with an address, then the problem lies in DECnet, not DECdns. If a command works with a DECnet address but not with a node name, then the problem involves DECdns.

To isolate the source of a problem, type the following commands, in the order shown:

1. Enter the following `SET HOST` command to connect to the local system. If this command fails, DECnet is at fault. DECdns cannot operate.

```
$ SET HOST 0
```

2. Now use the `SET HOST nn.nnn` command to connect to the server that stores the information you are looking up. Here `nn.nnn` is a host node address, as in the following example:

```
$ SET HOST 24.723
```

After these steps, troubleshooting becomes more complex. The next best tracing tool is `CDI$TRACE`. Start `CDI$TRACE` in one window (`MCR CDI$TRACE`), and then execute the command that fails in another. Review the output closely. Often the failed lookup reveals that the information is first being looked up in the `CDI LOCAL:` namespace, or under another name you had not expected as the target of a lookup. If you do not see a lookup to DECdns listed in the `CDI$TRACE`, then DECnet is not looking for the information from DECdns.

Sometimes an out-of-date entry is listed in the `LOCAL:` cache. You can purge the entire CDI cache by using the following NCL command:

```
$ MCR NCL FLUSH SESSION CONTROL NAMING CACHE ENTRY "*" "
```

Or, you can purge single entries by specifying them individually in place of the asterisk (*) in the command example. (Use the quotes in any case.)

Next, you can use the CTF (Common Trace Facility) trace tool for debugging Session Control (and perhaps other parts of DECnet-Plus). Use CTF as shown in the following example:

```
$ DELETE CTF*.DAT;* ❶  
$ TRACE CTF> START TRACE SESSION *  
CTF> EXIT ❷  
$ TRACE CTF> STOP  
CTF> ANAL/TRACE/FULL/OUT=filename.ext ❸  
CTF> EXIT $ TYPE filename.ext
```

- ❶ Deletes old trace files.
- ❷ Do whatever you want while tracing.
- ❸ Use any file name except CTF* .DAT.

If you have an extra window, you can also use CTF to watch the trace live by entering the following command:

```
CTF> START/LIVE SESSION
```

Appendix A. DECdns Naming Guidelines

This appendix defines the valid character set and syntax rules for DECdns names. It also contains general guidelines for naming namespaces, clearinghouses, directories, and their contents.

A.1. Valid Characters and Syntax Rules

A name can be any combination of letters, digits, and certain punctuation characters from the ISO Latin-1 character set. Valid characters include any in Figure A.2 that appear in a white or lightly shaded box. Characters in lightly shaded boxes must be enclosed in quotation marks (") to be valid. Characters in dark boxes are not valid. Binary names consist of pairs of hexadecimal characters and must be preceded by %X or %x.

DECdns preserves the case of names as they are entered. Lookups, however, are case insensitive, so it is not possible to create two names that differ only in their case. For example, requests to look up .MYNODE, .mynode, and .MyNode would all produce the same result. Similarly, if someone attempted to create all three of those names, only the first attempt would succeed.

A full name, including the namespace nickname, can have as many as 511 characters, as illustrated in Figure A.1.

Figure A.1. Full Name

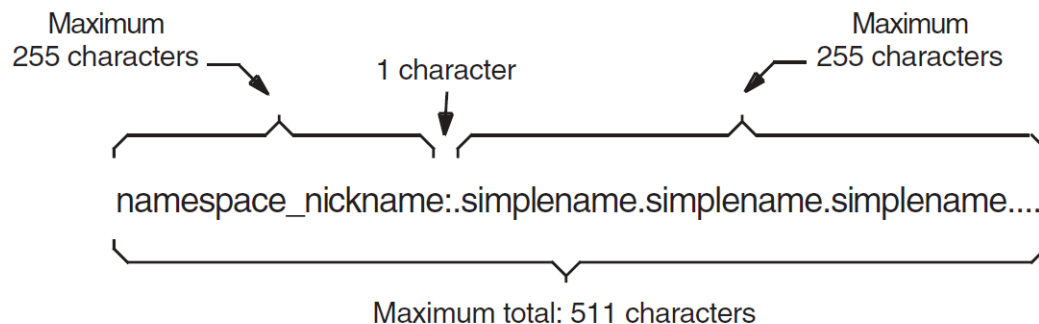

ZK-2825A-GE

Figure A.2. Character Codes in DECDns Names

Col Row	0			1			2			3			4			5			6			7		
0	NUL	0 0 0	DLE	20 16 10	SP	40 32 20	0	60 48 30	@	100 64 40	P	120 80 50	'	140 96 60	p	160 112 70								
1	SOH	1 1 1	DC1	21 17 11	!	41 33 21	1	61 49 31	A	101 65 41	Q	121 81 51	a	141 97 61	q	161 113 71								
2	STX	2 2 2	DC2	22 18 12	"	42 34 22	2	62 50 32	B	102 66 42	R	122 82 52	b	142 98 62	r	162 114 72								
3	ETX	3 3 3	DC3	23 19 13	#	43 35 23	3	63 51 33	C	103 67 43	S	123 83 53	c	143 99 63	s	163 115 73								
4	EOT	4 4 4	DC4	24 20 14	\$	44 36 24	4	64 52 34	D	104 68 44	T	124 84 54	d	144 100 64	t	164 116 74								
5	ENQ	5 5 5	NAK	25 21 15	%	45 37 25	5	65 53 35	E	105 69 45	U	125 85 55	e	145 101 65	u	165 117 75								
6	ACK	6 6 6	SYN	26 22 16	&	46 38 26	6	66 54 36	F	106 70 46	V	126 86 56	f	146 102 66	v	166 118 76								
7	BEL	7 7 7	ETB	27 23 17	'	47 39 27	7	67 55 37	G	107 71 47	W	127 87 57	g	147 103 67	w	167 119 77								
8	BS	10 8 8	CAN	30 24 18	(50 40 28	8	70 56 38	H	110 72 48	X	130 88 58	h	150 104 68	x	170 120 78								
9	HT	11 9 9	EM	31 25 19)	51 41 29	9	71 57 39	I	111 73 49	Y	131 89 59	i	151 105 69	y	171 121 79								
10	LF	12 10 A	SUB	32 26 1A	*	52 42 2A	:	72 58 3A	J	112 74 4A	Z	132 90 5A	j	152 106 6A	z	172 122 7A								
11	VT	13 11 B	ESC	33 27 1B	+	53 43 2B	;	73 59 3B	K	113 75 4B	[133 91 5B	k	153 107 6B	{	173 123 7B								
12	FF	14 12 C	FS	34 28 1C	,	54 44 2C	<	74 60 3C	L	114 76 4C	\	134 92 5C	l	154 108 6C		174 124 7C								
13	CR	15 13 D	GS	35 29 1D	-	56 45 2D	=	75 61 3D	M	115 77 4D]	135 93 5D	m	156 109 6D	}	175 125 7D								
14	SO	16 14 E	RS	36 30 1E	.	56 46 2E	>	76 62 3E	N	116 78 4E	^	136 94 5E	n	156 110 6E	~	176 126 7E								
15	SI	17 15 F	US	37 31 1F	/	57 47 2F	?	77 63 3F	O	117 79 4F	_	137 95 5F	o	157 111 6F	DEL	177 127 7F								

KEY: Valid characters
 Valid characters if enclosed in quotation marks
 Invalid characters

!	41	Octal
	33	Decimal
	21	Hex

ZK-1784A-GE

Table A.1 defines syntax rules for external DECDns names, in Backus-Naur form. The left column shows a component of a name or a type of name, and the right column shows the valid syntax. For example, an EasyNameChar is any of the characters shown in Figure A.2 that is valid without quotation marks, and a HardNameChar is any character that must be enclosed in quotation marks to be valid. An EasySimpleName can consist of one EasyNameChar or a sequence of EasyNameChars. A FullName can consist of a simple name string (SimpleNameStr) or a sequence of simple name strings separated by dots.

Table A.1. External Name Syntax in Backus-Naur Form

Name Component/Type		Valid Syntax
EasyNameChar	←	{ Set of characters that are valid without quotation marks }
HardNameChar	←	{ Set of characters that are valid when enclosed in quotation marks }
Separator	←	.
Quote	←	"
WildChar	←	<EasyNameChar> ? *
Ellipsis	←	<Separator> <Separator> <Separator>
AnyNameChar	←	<EasyNameChar> <HardNameChar> <Quote> <Quote>
HexChar	←	0 1 2 3 4 5 6 7 8 9 A B C D E F a b c d e f
HexRadix	←	%X %x
HexPair	←	<HexChar> <HexChar>
HexString	←	<HexPair> <HexString> <HexPair>
EasySimpleName	←	<EasyNameChar> <EasySimpleName> <EasyNameChar>
HardSimpleName	←	<AnyNameChar> <HardSimpleName> <AnyNameChar>
QuotedSimpleName	←	<Quote> <HardSimpleName> <Quote>
HexSimpleName	←	<HexRadix> <HexString>
WildSimpleName	←	<WildChar> <WildSimpleName> <WildChar>
SimpleName	←	<EasySimpleName> <QuotedSimpleName> <HexSimpleName>
MaybeNullSimpleName	←	<SimpleName> <Quote> <Quote>
NSNickName	←	<EasySimpleName>:
SimpleNameStr	←	<SimpleName> <SimpleNameStr> <Separator> <SimpleName>
WildNameStrNoE	←	<WildSimpleName> <SimpleNameStr> <Separator> <WildSimpleName>
WildNameStr	←	<Wild-NameStrNoE> <SimpleNameStr> <Ellipsis> <WildNameStrNoE> <Ellipsis>
FullName	←	<SimpleNameStr> <Separator> <SimpleNameStr> <Separator>
WildFullName	←	<WildNameStr> <Separator> <WildNameStr>
NSNFullName	←	<FullName> <NSNickName> <FullName>
NSNWildFullName	←	<WildFullName> <NSNickName> <WildFullName>

A.2. General Naming Guidelines

As you choose all DECDns names, consider the following guidelines:

- A name should be meaningful and easy for its users to remember and type. Give meaning to a name by making it descriptive of the resource it names. For example, `.Aero.Dev.Project_disk` could be the name of the DECDfs access point used by a company's aerospace development division, and `.Sales.Topdollar` could be the name of a node in the company's sales division.
- A name should be as short as is practical without causing it to lose meaning or uniqueness.

- If you create a directory hierarchy, choose directory names that are stable and are not likely to be affected by reorganizations or changes in product strategy. It is difficult to change existing directory names, especially at high levels in the namespace. Also, a change in a directory name affects all applications that use names in that directory, as well as any users who memorized the full name of a resource or created a local name for it. See Chapter 2 for details on how local name substitution works.

A.3. Guidelines for Naming Clearinghouses

If you configure your node as a DECDns server, you must supply a DECDns name for the clearinghouse that the server will manage. Use the following guidelines for naming clearinghouses:

- In networks of fewer than 50 DECDns servers, name all clearinghouses in the root directory (for example, `.Bonn_CH`). This enables you to automatically comply with two special clearinghouse rules that protect the name service's ability to find names. In networks of 50 or more DECDns servers, you should name some clearinghouses at levels below the root. See Appendix B for details.
- Including a suffix like `_CH` at the end of clearinghouse names (for example, `.Paris_CH` or `.Sales_CH`) can help you to easily identify clearinghouse names and avoid accidentally deleting them. Tightly controlling access to clearinghouse names also can help prevent accidental deletion.
- Avoid naming a clearinghouse based on the name of the server node where it exists. Although using the node name conveniently indicates the exact location of a clearinghouse, it can make things confusing if you later move the clearinghouse to another node, because you cannot rename a clearinghouse once it is created. VSI does not recommend naming a clearinghouse based on the node where it currently exists. Instead, consider naming clearinghouses based on the site, city, or region where they are located. Even if you move a clearinghouse, you are not likely to move it far from the site or city where it resides.
- If you intend to create an additional clearinghouse on an existing server system, be sure to choose a name for the new clearinghouse that is different than the name of the clearinghouse that currently resides on the system.

A.4. Guidelines for Naming Namespaces

When you create a new namespace, you must supply both a namespace nickname and a clearinghouse name (the first node in a new namespace must configure as a DECDns server). Use the following guidelines for choosing a namespace nickname:

- Choose a short and simple namespace nickname. When you refer to a name in your clerk's default namespace, it is not necessary to specify a namespace nickname. However, the namespace nickname still appears in command output, and even though the nickname can be as long as 255 characters, it makes sense to keep it short.
- Because a namespace has no relationship to any individual node, you should give the namespace a nickname that is meaningful to users networkwide. You might base the namespace nickname on your company's name. For example, a company called International Air Freight could have a namespace nickname of IAF. Choose the namespace nickname carefully; it is inconvenient to change it.
- You might decide to create a test namespace so you can become familiar with the DECDns software. If you do, give the namespace a nickname like Test to clearly indicate its purpose.

Do not give a test namespace a nickname that you eventually want to use for a networkwide namespace. Namespace nicknames are difficult to reuse once they have been established in clerk caches throughout the network.

Appendix B. Special Clearinghouse Rules

Two rules governing the creation of clearinghouses and the directories they can contain help to ensure that DECdns can look up a name. The DECdns software enforces the rules through defaults and error messages; so, in general, you are protected from breaking them. The only time you must explicitly follow the rules is when you recover a lost or permanently unavailable clearinghouse. Understanding the rules can help you interpret error messages you might receive, and can help prevent namespace design problems that result in errors during configuration. This appendix introduces the clearinghouse rules and explains their significance.

Clearinghouse Rule 1—Every clearinghouse must contain either the root directory or a directory whose name is closer to the root than the clearinghouse's name.

This rule ensures that no matter what clearinghouse a clerk starts from, it eventually finds the root directory. The clerk must always be able to locate a replica of the root because, as in the case illustrated in Chapter 2, the clerk must sometimes find the root and work down from it to find a name.

DECdns enforces clearinghouse rule 1 by requiring that the first replica you place in a new clearinghouse (the initial replica) complies with the rule. The software also prevents you from deleting a replica if that replica is the last one in the clearinghouse that complies with the rule.

During configuration, rule 1 is easy to comply with if you name all clearinghouses in the root directory. If you will have fewer than about 50 servers in the namespace, just name all clearinghouses in the format *.clearinghouse-name*, and replicate the root directory in every new clearinghouse that you create.

If you do choose to name clearinghouses in a directory other than the root, count simple names to ensure compliance with the rule. “Closer to the root” is another way of saying “having fewer simple names.” So when you create a new clearinghouse, the number of simple names in the full name of its initial replica must be fewer than the number of simple names in the clearinghouse's name.

The namespace structure shown in Figure B.1 helps illustrate rule 1:

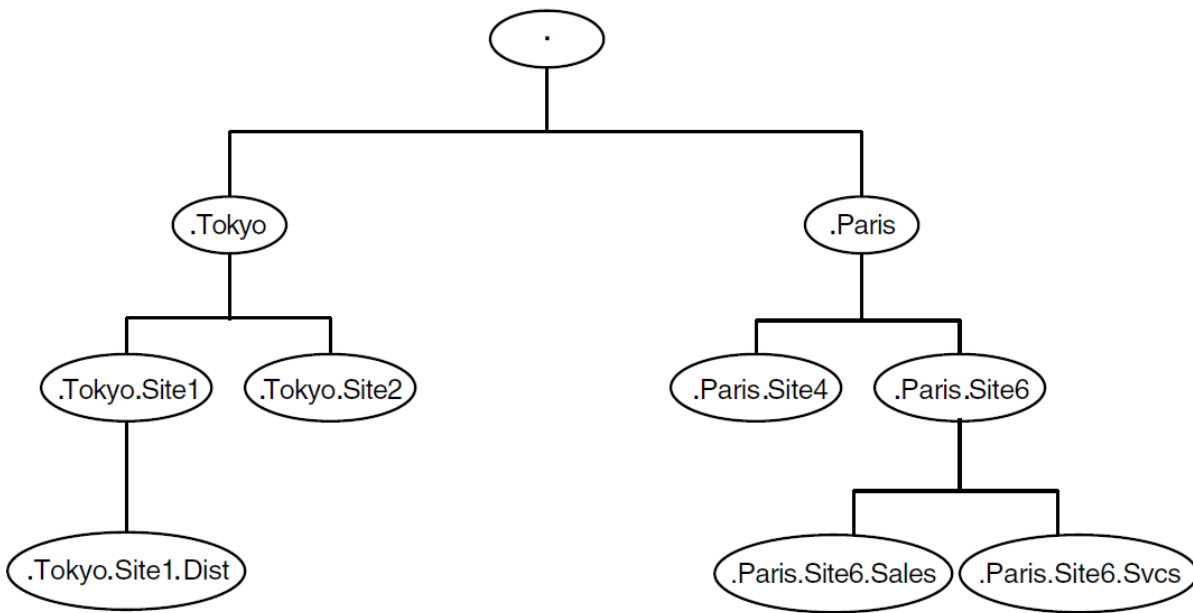
Figure B.1. Sample Namespace Structure

ZK-2617A-GE

Suppose you have a namespace with a root directory and three lower levels of directories, as shown in the figure. You want to name a clearinghouse `.tokyo.site1.local_ch`, thereby storing its object entry in the `.tokyo.site1` directory. To satisfy rule 1, the `.tokyo.site1.local_ch` clearinghouse can contain a replica of any of the following directories:

- `.` (the root)
- `.Tokyo`
- `.Paris`
- `.Tokyo.Site1`
- `.Tokyo.Site2`
- `.Paris.Site4`
- `.Paris.Site6`

The `.tokyo.site1.local_ch` clearinghouse cannot contain replicas of the following three directories, unless at least one other replica with a shorter name also exists in the clearinghouse:

- `.tokyo.site1.dist`
- `.paris.site6.sales`
- `.paris.site6.svcs`

These directories, and any others with three or more simple names, would not be able to exist alone in the `.tokyo.site1.local_ch` clearinghouse because they have the same number of simple names as the clearinghouse (three).

Clearinghouse Rule 2—Every directory other than the root must have a replica in at least one clearinghouse whose name is closer to the root than the directory itself is.

As with rule 1, counting simple names is an easy way to check compliance with this rule. When you create a new directory, the number of simple names in its full name must be equal to or greater than the number of simple names in the full name of the clearinghouse where you create it. Later, as you add and remove replicas in different clearinghouses, at least one replica must remain in a clearinghouse that complies with rule 2.

Again, the simplest way to comply with rule 2 is to configure all clearinghouses in the root. By limiting all clearinghouse names to one simple name, you can create any directory and be assured that its number of simple names is equal to or greater than the number of simple names in the name of the clearinghouse where it is created.

Suppose, in the namespace shown in the previous figure, you create the clearinghouse `.tokyo.site1.local_ch` and try to create a directory in it called `.admin`. That directory consists of one simple name, whereas the clearinghouse has three simple names, so DECdns prevents you from creating the directory there.

To comply with rule 2, you would first have to create the `.admin` directory in a clearinghouse with a shorter name, and then replicate it into the `.tokyo.site1.local_ch` clearinghouse. For example, creating the directory in a clearinghouse called `.hq_ch` would satisfy rule 2, because that clearinghouse name consists of one simple name—the same number of simple names in the name of the `.admin` directory.

Rule 2 ensures that the clerk can find any directory without having to look up a clearinghouse object entry that, in itself, would require looking up the target directory. More specifically, the rule ensures that a replica containing a clearinghouse object entry exists in at least one clearinghouse other than the clearinghouse that the entry describes.

The protection that rule 2 provides is important because DECdns looks up a clearinghouse object entry when no other method of finding the clearinghouse produces the correct address. For example, suppose you move a clearinghouse from one node to another. DECdns updates the address in the clearinghouse object entry immediately. However, directories with replicas in that clearinghouse, and their associated child pointers, temporarily retain the inaccurate address in their `DNS$Replicas` attributes. DECdns places the correct address in those attributes during a skulk or an update propagation. The clearinghouse object entry is therefore the only place where a clearinghouse address is always guaranteed to be accurate, and the clerk must be able to look up that object entry in a clearinghouse other than the one it is trying to find.

Clearinghouses named in directories other than the root are more complex to administer than those named in the root, because of the restrictions rule 2 places on creating and removing replicas in them. For that reason, VSI recommends that the full names of clearinghouses do not contain more than three simple names.

Appendix C. DECdns Error Messages

This appendix lists error messages reported by the DECdns Control Program. The messages are listed in alphabetical order by message text string. Following each message is an explanation of the conditions that generated the message, and some general advice on how to proceed.

A known namespace with this name or namespace creation timestamp (NSCTS) already exists

Explanation: The name or NSCTS of the namespace you specified in your `create dns clerk known namespace` command is already known to the clerk.

User Action: None, or reenter your command and specify a namespace currently unknown to the clerk.

A manual nameserver with this name already exists

Explanation: The name of the server you specified in your `create dns clerk manual nameserver` command is already known to the clerk.

User Action: None or reenter your command and specify a remote server currently unknown to the clerk.

A remote clearinghouse with this name or CTS already exists

Explanation: The name or creation timestamp (CTS) of the namespace you specified in your `create dns clerk remote clearinghouse` command is already known to the clerk.

User Action: None, or reenter your command and specify a clearinghouse currently unknown to the clerk.

Bad local name abbreviation translation

Explanation: A local name abbreviation translation is invalid because it contains invalid characters or it causes a translation loop.

User Action: Review the logical names in the `DNS$SYSTEM` logical name table (this is where local name abbreviation translation occurs).

Cannot delete crucial replica

Explanation: You attempted to delete a replica crucial to the preservation of clearinghouse rule 2. Deleting the replica would cause a loss of connectivity in the namespace.

User Action: See Appendix B for complete information on the clearinghouse rules. See Appendix D for a description of the Crucial Replica server event.

Cannot delete the clerk while it is enabled

Explanation: You attempted to delete a DECdns clerk while it was enabled (in the on state).

User Action: Use the `disable dns clerk` command to disable the clerk. Then, use the `delete dns clerk` command to delete the clerk.

Cannot delete the current default namespace

Explanation: The namespace nickname you specified in your `delete dns clerk known namespace` command is the default namespace for this clerk. You cannot delete a clerk's default namespace.

User Action: None or use the DECdns configuration program to select a new default namespace for the clerk. Then, use the `delete dns clerk known namespace` command to delete the old default namespace.

Cannot delete the entity when it is enabled

Explanation: You attempted to delete a server while it was enabled (in the on state).

User Action: Use the `disable dns server` command to disable the server. Then, use the `delete dns server` command to delete the server.

Cannot upgrade replica in old clearinghouse

Explanation: DECdns was unable to upgrade a replica because the clearinghouse in which it is stored was created with an earlier version of DECdns. DECdns cannot upgrade a directory to a later version until all replicas in its replica set are stored in clearinghouses created with the later version of the server software.

User Action: Delete the replicas created in earlier clearinghouses, upgrade the server software on the servers where those clearinghouse reside, then re-create the replicas in their original locations.

Clearinghouse clearinghouse-name duplicated

Explanation: You specified the same clearinghouse name more than once in the preceding `set directory to new epoch` command.

User Action: Reenter the command, omitting the duplicate clearinghouse specification.

Clearinghouse clearinghouse-name exclusion argument missing

Explanation: You did not account for clearinghouse **clearinghouse-name** (which stores a replica of the directory that you specified) in your preceding `set directory to new epoch` command.

User Action: If the replica at this clearinghouse is still a part of the directory's replica set, you must include the clearinghouse name and the replica type in the command. If you intend to exclude the replica from the replica set, use the `exclude` argument in the command. See Chapter 9 for information on how to exclude a replica from a replica set.

Clerk is not enabled

Explanation: The clerk process on this system has died. Any of the following conditions may have caused the error:

- The clerk may have been deliberately disabled and deleted.
- The clerk process may have failed because of some other internal problems.

User Action: Run the Network Control Language (NCL) startup script or use the `create dns clerk` (or the `@SYS$STARTUP:DNS$CLERK_STARTUP` command) followed by the `enable dns clerk` commands) to re-create and enable the clerk process. See Section 6.7. Use the `show dns clerk` command and specify the `state` attribute to verify that the clerk is in the `on` state.

Clerk timeout occurred before any modifications completed

Explanation: DECdns did not complete the operation you requested within the allotted clerk timeout period, or the clerk crashed while trying to process your request. No modifications were made in the namespace.

User Action: Use the `show dns clerk` command and specify the `state` attribute to verify that the clerk is running and is in the `on` state. Reenter your command. If the error recurs, use the `set dns clerk` command to increase the value of the clerk's `clerk timeout` attribute.

Clerk timeout occurred, modifications may have completed

Explanation: DECdns did not complete the operation you requested within the allotted clerk timeout period, or the clerk crashed while trying to process your request. Requested modifications may or may not have been made to the target name.

User Action: Verify that the clerk is running and is in the `on` state. Check to see if DECdns completed the operation. If not, reenter your command. If the error recurs, use the `set dns clerk` command to increase the value of the clerk's `clerk timeout` attribute.

Conflicting arguments specified

Explanation: Your command contains two or more conflicting arguments. The specified arguments cannot be included within a single command.

User Action: Reenter your command, omitting the conflicting argument (or arguments).

Corrupted response returned by clearinghouse,

Explanation: The clerk received a corrupted response from the first clearinghouse to which it connected and was unable to retry its request at another clearinghouse because no other clearinghouses containing the requested information were available. The data corruption may be caused by a hardware or software problem on either the clerk or server system.

User Action: None immediately. You should examine the `syslog` file to identify the server and clearinghouse to which the clerk was connected when the error was returned. If the error recurs, always specifying the same server and clearinghouse, the data corruption is most likely caused by the hardware or DECdns server or clearinghouse software on the server system. If the error recurs specifying a variety of different clearinghouses, the data corruption may be due to a hardware or software problem on the clerk system. If the error persists, contact your network service providers to verify that the network hardware is functioning properly, or contact your namespace administrators or your VSI support representative.

Data corruption detected at clearinghouse

Explanation: An error occurred while DECdns was accessing the data in a clearinghouse. The clearinghouse may be corrupted.

User Action: Refer to the DECnet event log to determine the cause of the error. See Chapter 12 for instructions on how to recover a corrupted clearinghouse database.

DECdns license is not present or is invalid

Explanation: While trying to create the DECdns server on this server node (during system startup or after entering the `@SYS$STARTUP:DNS$SERVER_STARTUP` command), the DECdns server license could not be found or had been rendered unusable.

User Action: To determine the specific cause of the error, examine the `DNS$SERVER_ERROR.LOG` file systems. Invoke the License Management Facility (LMF) to reload or activate the server license. See the LMF documentation for complete information on how to use the License Management Facility.

Directory creation in this clearinghouse violates clearinghouse rules

Explanation: Creating a directory in the clearinghouse that you specified violates the clearinghouse rules.

User Action: Create the directory in another clearinghouse that is named closer to the root. If necessary, you can then create a replica of the new directory in the clearinghouse where you originally intended to create the directory. See Appendix B for a complete description of the clearinghouse rules.

Directory must be empty to be deleted

Explanation: You attempted to delete a directory that still contains entries.

User Action: Delete the contents of the directory before you reenter the `delete directory` command. Make sure you do not accidentally delete any clearinghouse object entries.

Directory replicas are not synchronized

Explanation: During a skulk of a directory, the update procedure found that the values stored in the `DNS$Epoch` attribute of each replica in the directory's replica set were not identical.

User Action: Use the `set directory to new epoch` command to synchronize all members of the directory's replica set.

Distributed update contained an invalid timestamp

Explanation: While propagating updates, DECdns detected that an update contained an invalid timestamp. The discrepancy between the server that issued the invalid timestamp and the other DECdns servers on the network is greater than 4 minutes.

User Action: Verify that DECdts is running and is correctly synchronizing all servers listed in the message text. This error does not necessarily indicate that clocks are not synchronized. Check the `SYS$MANAGER:DNS$SERVER.LOG` file for additional information about this error. See Section 12.15 for more information on fixing clock synchronization errors. If the error persists for more than 48 hours after the clocks have been corrected, contact your VSI support representative for help on correcting the problem. See the *VSI DECnet-Plus for OpenVMS DECdts Management* for information on clock synchronization.

Inappropriate name use

Explanation: You specified a name in an inappropriate context. For example, you entered a `set directory` command specifying a name that is not a directory name.

User Action: Reenter your command correctly.

Insufficient local resources

Explanation: The system was unable to provide adequate memory or communications resources to process your request.

User Action: Monitor the available memory and check system log files to determine the current availability of system resources. If necessary, allocate additional resources.

Insufficient resources at server

Explanation: Available resources at the responding DECdns server were insufficient to process your request. The server system was unable to provide adequate memory, communications, or other resources.

User Action: Reenter your command.

Insufficient rights to perform requested operation

Explanation: The user account from which you entered the command does not have the required DECdns access rights to perform the operation you requested.

User Action: Assuming you have adequate access rights, grant yourself the appropriate access to perform the operation. Otherwise, contact your namespace administrator to get the appropriate access, or reenter the command while you are logged in to an account that has the required access.

Invalid argument

Explanation: One or more of the specified argument values is invalid. Argument values may be syntactically incorrect or may be outside the range of allowed values. For example, you may have specified a `DNS$CTS` value that refers to a future time.

User Action: Refer to Chapter 11 for descriptions of allowed argument values and proper usage. Reenter the command, specifying valid argument values.

Invalid name

Explanation: The command you entered contains misspelled words, illegal characters, or other typographical errors. You may have included extraneous words or omitted required node, option, or argument specifications. Command arguments and options may not appear in proper sequence.

User Action: Invoke DECdns online help or refer to Chapter 11 for a description of proper syntax for the command you are trying to use. Reenter your command correctly.

Note

The DECdns Control Program ordinarily detects all command syntax errors on the command line and displays the `Syntax error` message. Appearance of the `Invalid name` message can sometimes indicate that:

- A merge operation you requested (and which involved valid full names at the command line) was concatenated internally to produce a new full name that was improperly formed or of illegal length.
- An internal conversion routine or other operation failed.
- A software error has developed within the control program itself.

If the `Invalid name` error message is displayed repeatedly in response to a command you are sure you entered correctly, contact your VSI support representative.

More than one master replica specified

Explanation: You specified more than one master replica in your preceding `set directory to new epoch` command. A directory's replica set can contain only one master replica.

User Action: Reenter your command specifying only one clearinghouse location for the directory's master replica.

No replica of specified directory exists at clearinghouse

clearinghouse-name

Explanation: The clearinghouse **clearinghouse-name** (which you specified in the `exclude` argument of your preceding `set directory to new epoch` command) does not store a replica of the specified directory.

User Action: Enter the `show directory` command and specify the `DNS$Replicas` attribute to display a list of the clearinghouses that contain replicas of the specified directory. Then, reenter your original command, specifying the correct clearinghouse names.

Operation must be performed at master replica of root directory

Explanation: You entered a command requesting an operation that must be directed to the clearinghouse that stores the master replica of the root directory.

User Action: Enter the `show directory` command for the root directory (`.`) and specify the `DNS$Replicas` attribute to determine the name and location of the clearinghouse that stores the master replica. Reenter your original command, specifying that clearinghouse.

Operation not supported by Local namespace

Explanation: The clerk on this node is using the Local namespace rather than the fully distributed DECdns implementation. The command you entered specifies an operation that is not supported by the Local namespace.

User Action: None.

Possible cycle detected

Explanation: While processing your command, DECdns detected a possible soft link loop or group loop. A soft link loop occurs when a soft link (in a series of two or more soft links) points back to itself. A group loop occurs when two or more groups include each other as group members.

User Action: See Chapter 12 for instructions on how to break soft link loops and group loops.

Replica of specified directory cannot be created in old clearinghouse

Explanation: You attempted to create a replica of a directory in a clearinghouse running an earlier version of the DECdns software than the version with which the directory itself was created. For example, you cannot create a replica of a Version 2 directory in a clearinghouse maintained with DNS Version 1 software.

User Action: Upgrade the DECdns software of the server on which the clearinghouse resides, or create the replica in a clearinghouse that was created with the later version of the software.

Replica set of specified directory contains more than one replica

Explanation: You tried to delete a directory whose replica set still contains one or more read-only replicas.

User Action: Enter the `show directory` command and specify the `DNS$Replicas` attribute to display a list of the clearinghouses that contain replicas of the directory. You must delete all read-only replicas before you can delete the directory's master replica.

Requested clearinghouse exists but is not available

Explanation: The clearinghouse that you tried to access resides on the specified server but is not currently available. The clearinghouse may not be in the `on` state.

User Action: Enter the `show dns server clearinghouse` command and specify the `state` attribute to verify that the clearinghouse is in the `on` state. Reenter your original command when the clearinghouse is in the `on` state.

Requested function not supported by this version of architecture

Explanation: The function you requested is not supported by the current version of the DECdns architecture.

User Action: None.

Requested name does not exist

Explanation: Any of the following conditions may have caused the error:

- The name you tried to access does not exist in the namespace.
- The name exists but is newly created and is not yet known to the clearinghouse with which you are communicating.
- The name you tried to access is being deleted.
- The requesting principal (the user account from which you entered the command) does not have read access to the requested name.
- Read access is granted to the requesting principal through the use of an access control group, but the `group` flag is not specified in the ACE associated with the name.
- For a directory name, the only ACE specifying the requesting principal is a default ACE. Default ACEs grant access only to the future contents of a directory and not to the directory itself.
- You mistyped the name.

User Action: Assuming you have adequate access rights, try to create the name yourself. If the name exists, the creation fails and the following error message is displayed:

`Specified full name already exists`

If this occurs, ask your namespace administrator (or the owner of the name) to grant read access to the name for your user account. If you mistyped the name, reenter your command specifying the correct name.

Requested operation would result in lost connectivity to root directory

Explanation: You entered a command requesting an operation that would have resulted in a loss of connectivity with the root of the namespace. DECdns cannot process your request.

User Action: None.

Requested optional function is not implemented in this release

Explanation: You entered a command requesting an operation that is supported by the current version of the DECdns architecture, but is defined as optional and has not been implemented in this release of the DECdns software.

User Action: None.

Requesting principal could not be authenticated to the clearinghouse

Explanation: DECnet node verification failed. The server that stores the master replica of the directory (or contents) you are trying to read or modify was unable to verify the DECnet node name portion of the principal associated with the clerk from which you made the request.

User Action: Make sure that the following conditions are satisfied, then reenter your command:

- Verify that a node object entry representing the requesting clerk exists in the namespace and can be reached, at the time you enter your command, by the server storing the master replica.
- Make sure the `dns$server` account (**nodename.dns\$server**) on the server storing the master replica has read access to the node object entry.
- Make sure the address (`DNA$Towers` attribute) associated with the node object matches the actual address of the requesting clerk.

See Section 12.12 for more information on how to perform these tasks.

Responding entity in wrong state to process requested operation

Explanation: A responding entity (a DECdns clerk, DECdns server, clearinghouse, or replica) is not in the on state and cannot process your request.

User Action: Verify that the entity you are trying to access is in the on state before you reenter your command.

Server is in the wrong state to initialize namespace

Explanation: During the DECnet configuration process, the namespace creation process failed because the DECdns server was not enabled (not in the on state).

User Action: Enter the `enable dns server` command to enable the server.

Server is in the wrong state to be disabled

Explanation: The DECdns server running on the node you specified in your `disable dns server` command was not enabled (in the on state) when you issued the command.

User Action: Use the `show dns server` command to verify the status of the server.

Server process has insufficient access to clearinghouse

Explanation: The `DNS$Server` principal on the requesting server has insufficient access to a clearinghouse that stores the name the server was trying to access.

User Action: Have your namespace administrator (or the manager of the server on which the clearinghouse resides) grant the `DNS$Server` principal on the requesting server the access it requires to perform the requested operation.

Skulk in progress terminated, superseded by more recent skulk

Explanation: A skulk in progress contacted a replica and found that the replica was modified by a more recent skulk. The skulk in progress terminates.

User Action: None.

Software error detected in clerk

Explanation: DECdns detected a software problem in the clerk interface.

User Action: See Chapter 12 for information on recovering from this error.

Software error detected in server

Explanation: DECdns detected a software problem in a DECdns server.

User Action: See Chapter 12 for information on recovering from this error.

Specified attribute cannot be modified

Explanation: You attempted to modify the value of an attribute that cannot be modified.

User Action: None.

Specified attribute type is incorrect

Explanation: One or more of the attributes that you specified are not included in the correct attribute group (identifiers, characteristics, counters, or status).

User Action: Before you reenter the command, see Chapter 11 to determine the attribute group to which each of the specified attributes belongs.

Specified clearinghouse already contains a replica of that directory

Explanation: You tried to create a replica of a directory in a clearinghouse that already contains a replica of that directory. A clearinghouse can store only one replica of a directory.

User Action: None, or choose another clearinghouse in which to create the replica.

Specified clearinghouse does not contain a replica of that directory

Explanation: The clearinghouse you specified in the command does not contain a replica of the directory you are trying to access.

User Action: Enter the `show directory` command and specify the `DNS$Replicas` attribute to display the names of the clearinghouses that contain a replica of the directory you are trying to access. Reenter your original command and specify a clearinghouse that stores a replica of the target directory.

Specified clearinghouse does not exist

Explanation: The clearinghouse you specified in the command does not exist in the namespace.

User Action: Make sure you typed the full name of the clearinghouse correctly. Reenter the command and specify the correct name of an existing clearinghouse.

Specified directory does not allow clearinghouse name storage

Explanation: You attempted to name a new clearinghouse in a directory that does not permit storage of clearinghouse object entries. The directory's `DNS$InCHName` attribute is not set to `true`.

User Action: Use the `set directory` command to reset the value of the directory's `DNS$InCHName` attribute to `true`, then reenter your original command. See Chapter 12 for information on allowing a directory to store clearinghouse object entries.

Alternatively, you can name the new clearinghouse in a directory that already allows clearinghouse creation.

Specified full name already exists

Explanation: You cannot create the name that you specified because an identical name already exists in the namespace. (For directory creation, a directory of the same name may be in the process of being deleted.)

User Action: Make sure that the full name you specified is actually the name you intended to create. If it is, you must choose another name that does not already exist in the namespace.

Specified name exists but is not a soft link

Explanation: The name you specified exists in the namespace but is not a soft link.

User Action: Use the `directory link` command to display the names of all the soft links in the appropriate directory. Reenter your command and specify the correct name of the soft link that you are trying to access.

Specified nickname already assigned to another namespace

Explanation: In this clerk's cache, the namespace nickname you specified is already coupled with the NSCTS attribute of another namespace.

User Action: Specify a namespace nickname that is not already in use on your network.

Specified nickname is ambiguous

Explanation: According to this clerk's cached list of known namespaces, the nickname you specified in your command is coupled with the NSCTS attributes of two (or more) namespaces.

User Action: See Chapter 12 for information on how to eliminate the ambiguous namespace (or namespaces) or specify the NSCTS (rather than the nickname) of the appropriate namespace in your command. A namespace's NSCTS is guaranteed to be unique.

Specified nickname unknown to this clerk

Explanation: The namespace nickname you specified does not exist in this clerk's cached list of known namespaces.

User Action: Make sure that you entered the namespace nickname correctly. Use the `create dns clerk known namespace` command to add the namespace nickname to the list of known namespaces in the clerk's cache.

Specified object is not a group

Explanation: The object you specified in your command is not a group; its object class is not `DNS $Group`.

User Action: Use the `directory group` command to display the names of all the groups in the appropriate directory. Reenter your original command and specify the correct name of the group you are trying to access.

Specified soft link points to nonexistent name

Explanation: The **destination-name** (`DNS$LinkTarget`) to which the specified soft link points no longer exists (or may never have existed) in the namespace.

User Action: Enter the `delete link` command to delete the soft link, or use the `set link` command to modify the current **destination-name**.

Syntax error

Explanation: The DECdns Control Program detected a syntax error in your command before attempting to execute it. The command may contain misspelled words, illegal characters, or other typographical errors. You may have included extraneous words or omitted required node, option, or argument specifications. Command arguments and options may not appear in proper sequence.

User Action: Invoke DECdns online help or see Chapter 11 for a description of proper syntax for the command you are trying to use.

The DNS clerk entity already exists

Explanation: You tried to create a DECdns clerk on a node where a clerk already exists.

User Action: None.

The DNS clerk is not enabled

Explanation: You tried to disable a clerk that was not enabled (in the on state).

User Action: None, if you intend to disable the clerk.

The nameserver entity already exists

Explanation: You tried to create a DECdns server on a node where a server already exists.

User Action: None.

Unable to communicate with any DECdns server

Explanation: The clerk from which you issued your command was unable to communicate with any DECdns server capable of processing your request. Any of the following conditions may have caused the error:

- The requesting clerk was unable to establish a DECnet link to an appropriate DECdns server.
- The clerk was able to connect to an appropriate server, but the server was not in the on state.
- A clearinghouse containing a replica of the directory that stores the information you were trying to access was not in the on state.

User Action: Verify DECnet connectivity to an appropriate server node. Make sure that the server is in the on state. Make sure that at least one clearinghouse that stores a replica of the directory you want to access is reachable and is in the on state. See Section 12.2 for more information on how to handle communication errors.

Appendix D. DECdns Events

DECdns uses the DECnet-Plus event logger to record significant events for DECdns clerks, servers, and clearinghouses. By default, all DECdns events are turned on by the DECnet-Plus configuration program.

This appendix alphabetically lists DECdns events, explains their meanings and, where appropriate, suggests what action you should take.

Clerk Event

Parameters

Incompatible Protocol Error

The clerk received a response from a server running an incompatible or unsupported version (major version number) of the DECdns clerk/server protocol. A clerk can only communicate with other clerks or servers that are running the same version as (or one version earlier than) the protocol version that the clerk itself is running. This event increments the Incompatible Protocol Errors clerk counter.

Argument:

Version Received	Specifies the protocol version running on the responding entity.
------------------	--

Server Events

Parameters

Broken Lookup Paths

The clearinghouse on this server has become disconnected from clearinghouses that contain replicas closer to the root. Incoming requests that require the server to look downward in the hierarchy may still succeed, but requests requiring lookups in directories that exist closer to the root will fail because the parent of the directory does not seem to exist. Without a parent, the directory is cut off from upper levels of the hierarchy. This problem can be caused by either of the following conditions:

- During a directory lookup operation, the account (principal) under which the server is running (*nodename.dns\$server*) was found to have insufficient access to the child pointer of the target directory. (A directory's child pointer exists in its parent directory.) Access to a directory's child pointer is inherited from the access assigned to the directory's parent directory. To correct the problem, make sure the *nodename.dns\$server* principal has write access to the parent directory.
- The child pointer to the disconnected directory was accidentally deleted from its parent directory. See Chapter 12 for complete information on how to restore a lost child pointer.

This event increments the Times Lookup Paths Broken server counter.

Argument:

Orphan	Specifies the full name of the directory being accessed by the server at the time the disconnection was detected.
--------	---

Cannot Update Child Pointer

The server was unable to update a parent directory's `child_pointer` attribute (with update information stored in the child directory's `parent_pointer` attribute). This happens when the server is unable to contact all the clearinghouses that store a replica of the directory's parent directory and therefore cannot apply updates that occurred since the last skulk. One or more replicas of the parent directory may be temporarily unreachable. This event increments the Child Pointer Update Failures server counter.

This event may also be generated if the server was found to have insufficient access to perform the update. In this case, the Security Failure server event is also logged.

Arguments:

Directory	Specifies the full name of the directory for which the server's parent pointer tracking failed.
Reason	Specifies the reason for the update failure. Reasons are expressed as DECdns or operating system error messages.

If the Security Failure or Broken Lookup Paths events are also logged, take action on those events first. If DECdns only logs the Cannot Update Child Pointer event, then one or more of the clearinghouses that stores a replica of the directory being updated could not be contacted. This condition will be corrected when the server's ability to communicate with the clearinghouses is restored.

Crucial Replica

An attempt was made, from this server, to delete a replica that is crucial to the preservation of the clearinghouse rules. The clearinghouse rules require every directory to store at least one of its replicas in a clearinghouse that is named closer to the root than is the directory itself. (See Appendix B for complete information on the clearinghouse rules.) When the background process on the server detects that a crucial replica was deleted, it reverses the `delete_replica` operation and returns the replica to the on state.

This event is raised as a result of two separate `delete_replica` operations. Although each operation may be valid, the combination of the two operations is not. The server background process examines the combined deletions and reverses the deletion of the replica that will preserve the clearinghouse rules and restore the server's ability to communicate with the root directory. This event increments the Crucial Replica Removals Backed Out server counter.

Arguments:

Directory	Specifies the full name of the directory whose replica was being deleted when the server background process detected the failure.
Clearinghouse	Specifies the full name of the clearinghouse that stores the crucial replica whose removal caused the failure.

If you must remove a crucial replica from a clearinghouse, first create another replica of the directory in some other clearinghouse whose name is closer to the root directory than is the directory itself.

Incompatible Protocol Error

The server received a request from a clerk running an incompatible or unsupported version (major version number) of the DECdns clerk/server protocol. A server can only communicate with clerks that

are running the same version (or one version previous to) the protocol version that the server itself is running. This event increments the Incompatible Protocol Errors server counter.

Arguments:

Version Received	Specifies the protocol version running on the requesting entity.
Source	Specifies the full name of the node entity containing the clerk that generated the incompatible request.

Possible Cycle

The server detected a possible soft link loop or group loop while trying to resolve a name or group. This event increments the Possible Cycles server counter.

Argument:

Name	Specifies the full name being resolved when the loop was detected.
------	--

See Chapter 12 for information on how to break a soft link loop or group loop.

Security Failure

The server encountered an unexpected security failure while trying to perform an operation on behalf of a user or application, or while trying to perform an internal background operation. For example, the server, on behalf of a requesting application, was unable to create an object entry in a directory because the account under which the application was running (principal) did not have write access to the directory. This event increments the Security Failures server counter.

Arguments:

Accessing	Specifies the full name being accessed when the security failure was detected.
Source	Specifies the full name of the accessing principal.

Time Went Backward

The time on this server system appears to have gone backward.

Argument:

Time	Specifies the time after which you must reset the system clock to correct the problem.
------	--

This problem can occur when a user mistakenly sets the system time ahead to adjust for normal clock drift or for daylight saving time; then, after realizing an error was made, the user sets the system clock back again. All DECdns transactions that occur while a server's system clock is set ahead appear, to DECdns, to have occurred in the future. DECdns is unable carry out updates and other background operations on names that bear timestamps specifying future times.

If the future timestamps are only a few minutes or hours in the future, you can simply wait until the date and time expressed in the timestamps has passed. At that time, DECdns will continue to synchronize update information in the normal manner.

If the timestamps are so far in the future that you would need to wait for days or weeks before resuming normal operations, you must repair the damage manually.

Clearinghouse Events

Parameters

Clearinghouse Created

The clearinghouse was created by use of the `create dns server clearinghouse` command.

Clearinghouse Deleted

The clearinghouse was deleted by use of the `delete dns server clearinghouse` command.

Clearinghouse Disabled

The clearinghouse was disabled by use of the `disable dns server clearinghouse` command. This event increments the Disable Counts clearinghouse counter.

Argument:

How	Specifies how the clearinghouse was disabled: <code>graceful</code> or <code>abort</code> .
-----	---

Clearinghouse Enabled

The clearinghouse was enabled by use of the `enable clearinghouse` command. This event increments the Enable Counts clearinghouse counter.

[Clearinghouse Entry Missing]

The clearinghouse object entry that represents this clearinghouse in the name-space has disappeared, possibly because of accidental deletion. This event increments the Times Clearinghouse Entry Missing clearinghouse counter.

See Chapter 12 for instructions on how to restore a deleted clearinghouse object entry.

Data Corruption

The clearinghouse data files may have become corrupted. This event increments the Data Corruptions clearinghouse counter.

Argument:

Reason	Specifies why the integrity of the clearinghouse data is suspect. Reasons are expressed as DECdns or operating system error messages.
--------	---

Check the appropriate DECdns error messages in Appendix C and take the indicated user actions. See Chapter 12 for instructions on how to recover a corrupted clearinghouse.

Root Lost

The namespace tree has become disconnected; the root directory cannot be found starting from this clearinghouse. This condition can occur when the clearinghouse does not store at least one directory with both of the following properties:

1. The directory's name must be closer to the root (contain fewer simple names) than the name of the clearinghouse itself.

2. The directory must have its `DNS$InCHName` attribute set to `true`.

This event increments the Times Root Not Reachable clearinghouse counter.

To recover from this problem, use the `create replica` command to create (in this clearinghouse) a replica of some directory that satisfies the preceding requirements. The root directory is guaranteed to satisfy these requirements.

Skulk Failed

A skulk (initiated by this server) of some directory that stores a replica on this clearinghouse has failed. This event increments the Skulk Failures clearinghouse counter.

Arguments:

Directory	Specifies the full name of the directory being skulked.
Reason	Specifies why the skulk failed. Reasons are expressed as DECdns or operating system error messages.

Check the appropriate DECdns error messages in Appendix C and take the indicated user actions.

Upgrade Not Possible

The server where this clearinghouse resides was unable to upgrade a directory during a skulk of that directory. This event increments the Upgrades Not Possible clearinghouse counter.

Arguments:

Directory	Specifies the full name of the directory that could not be upgraded.
Why	Specifies why the attempted upgrade failed. Reasons are expressed as DECdns or operating system error messages.

Check the appropriate DECdns error messages in Appendix C and take the indicated user actions.

Appendix E. Location of DECdns Files

This appendix contains information on the location of the DECdns clerk and server files. E.1 list the locations of DECdns Version 2 files for OpenVMS systems.

Note that what files are on a system depends on whether the system has DECdns installed on it or it is a clerk-only system.

Table E.1. Location of DECdns Files on OpenVMS Systems

File	Description
SYS\$SPECIFIC:[SYSEXE]	
DNS\$CACHE.000000nnnn	The backing store file for the DECdns clerk cache. The extension part of the file name (000000nnnn) is incremented by 1 at each backing store update and is updated in the associated file dns\$cache.version.
DNS\$CACHE.VERSION	Contains the version of the dns\$cache backing store file.
SYS\$COMMON:[SYSEXE]	
DNS\$ADVER.EXE	Executable image file for DECdns advertisement process.
DNS\$ANALYZE.EXE	Executable image file for analyzing clerk protocol traces.
DNS\$CONFIGURE.EXE	Executable image file for DECdns configuration program.
DNS\$CONTROL.EXE	Executable image file for DNS management control program.
DNS\$CONVERT.EXE	Executable image file for converting DNS Version 1 files to DECdns Version 2 format.
DNS\$DIAG.EXE	Executable image file for DECdns diagnostics tool.
DNS\$DUMP.EXE	Executable image file for DECdns dump utility.
DNS\$SERVER.EXE	Executable image file for the server.
DNSBROWSER.EXE	Executable image file for the DECdns Browser utility.
DNSCP.BPT	Parse table for the DECdns Control Program.
DNSCP.MBF	Message text file for the DECdns Control Program.
SYS\$SPECIFIC:[SYSLIB]	
DNS\$NS_DEF_FILE.DAT	The server default file.
SYS\$COMMON:[SYSLIB]	
DNS\$CLIENT.EXE	DNS client (clerk) shareable library, the old version kept for backward compatibility with

File	Description
	systems having VMS software earlier than Version 5.3. (OpenVMS VAX only)
DNS\$PI.EXE	DECdns shared library of DECdns run-time routines. (OpenVMS VAX only)
DNS\$RTL.EXE	DECdns run-time library routines.
DNS\$\$SHARE.EXE	DECdns clerk shareable library. (OpenVMS VAX only)
DNSDEF.BAS	Definitions for DECdns application programming interface (API).
DNSDEF.FOR	Definitions for DECdns API.
DNSDEF.H	Definitions for DECdns API.
DNSDEF.MAR	Definitions for DECdns API.
DNSDEF.PAS	Definitions for DECdns API.
DNSDEF.PLI	Definitions for DECdns API.
DNSDEF.R32	Definitions for DECdns API.
DNSMSG.BAS	Definitions for DECdns API.
DNSMSG.FOR	Definitions for DECdns API.
DNSMSG.H	Definitions for DECdns API.
DNSMSG.MAR	Definitions for DECdns API.
DNSMSG.PAS	Definitions for DECdns API.
DNSMSG.PLI	Definitions for DECdns API.
DNSMSG.R32	Definitions for DECdns API.
SY\$\$HELP	
DECDNS_BROWSER.HLB	Help files for the DECdns Browser utility.
DNS\$CPHELP.HLB	Help files for the DECdns Control Program.
SY\$\$SPECIFIC:[SY\$\$STARTUP]	
DNS\$SERVER_STARTUP.COM	Server startup command file.
SY\$\$COMMON:[SY\$\$STARTUP]	
DNS\$CLERK_STARTUP.COM	Clerk startup command file.
DNS\$CLERK_STOP.COM	Clerk shutdown command file.
DNS\$SERVER_SHUTDOWN.COM	Server shutdown command file.
SY\$\$SPECIFIC:[SYSMGR]	
DNS\$CONVERT.COM	Used for converting DNS Version 1 files to DECdns Version 2 format.
DNS\$STARTUP.COM	DECdns startup command file.
DNS\$STOP.COM	DECdns shutdown command file.
NET\$DNS_CLERK_STARTUP.NCL	Clerk startup file with information specific for the node.
NET\$DNS_CLERK_STOP.NCL	Clerk shutdown file.

File	Description
NET\$DNS_SERVER_STARTUP.NCL	Server startup file with information specific for the node.
NET\$DNS_SERVER_STOP.NCL	Server shutdown file.
DNS\$ADVER_ERROR.LOG	Log file that records errors related to the DNS \$ADVER advertiser process.
DNS\$CHFAIL.LOG	Log file that records errors related to clearinghouse failures.
DNS\$SERVER.LOG	Log file that records server activity.
DNS\$SERVER_ERROR.LOG	Log file that records server errors.
DNS_FILES.TXT	File created when the clearinghouse is created, containing the path to the clearinghouse. It is necessary for starting up the DECdns server.
SYS\$COMMON:[SYSMGR] ¹	
DECNET_DNS_REGISTER.COM	DECnet-Plus registration tool used by DECNET_REGISTER.
DECNET_DNS_TOWERS.COM	Command file used by DECNET_REGISTER.
DECNET_REGISTER_DECDNS.COM	Part of the DECNET_REGISTER tool.
DNS\$CHANGE_DEF_FILE.COM	DECdns command file that changes default server.
DNS\$CLIENT_STARTUP.COM	DNS Version 1 clerk startup file left over if you have upgraded to DECdns Version 2.
DNS\$CLIENT_STOP.COM	DNS Version 1 clerk shutdown file left over if you upgraded to DECdns Version 2.
DNS\$CONFIGURE.COM	DECdns configuration program.
DNS\$CLERK_CLUSTER.NCL	Script file for clerks on clusters.
NET\$DNS_CLERK_STARTUP.NCL	Script file for clerk startup.
SYS\$SYSDEVICE:[DNS\$SERVER] ²	
<i>chfile</i> _CH.CHECKPOINT <i>n</i>	Clearinghouse checkpoint file, where <i>chfile</i> is the name of the clearinghouse file and <i>n</i> denotes an eight-digit number.
<i>chfile</i> _CH.TLOG <i>n</i>	Clearinghouse file, where <i>chfile</i> is the name of the clearinghouse file and <i>n</i> is the version number.
<i>chfile</i> _CH.VERSION	Clearinghouse file (where <i>chfile</i> is the name of the clearinghouse file) containing the value for the version number on <i>chfile</i> _CH.TLOG <i>n</i> .
SYS\$MESSAGE:	
DNS\$MESSG.EXE	Error message file.
SYS\$COMMON:[SYSHLP.EXAMPLES.DNVOSI]	
DNS_ADD_VALUE_TO_ATTRIBUTE.C	Programming example.
DNS_CREATE_OBJECT.C	Programming example.
DNS_READ_ATTRIBUTE.C	Programming example.

File	Description
SYSSCOMMON:[SYSSLDR]	
SYSSNAME_SERVICES.EXE	File that loads clerk system services.
SYSSNAME_SERVICES.STB	File that loads clerk symbol table.

¹The SYSSCOMMON:[SYSSMGR] directory contains files used for starting up DECdns tools and facilities.

²The SYSSSYSDEVICE:[DNS\$SERVER] directory and the clearinghouse files it contains are created during configuration.

Appendix F. DECdns Version Interoperability

DECdns is Version 2 of a product called VAX Distributed Name Service (DNS) Version 1. Version 1 and Version 2 clerks and servers can interoperate in the same namespace, with a few restrictions and considerations. This appendix summarizes interoperability considerations in a mixed Version 1 and Version 2 environment.

F.1. Version 2 Directories Cannot Be Replicated in Version 1 Clearinghouses

This restriction is a problem only if you modify the default behavior of Version 2 software. Every clearinghouse has a `DNS$DirectoryVersion` attribute, whose value determines the version number of all directories created in that clearinghouse. Version 2 software creates clearinghouses with a default directory version of 1, so that directories created in the clearinghouse can be replicated in either Version 1 or Version 2 clearinghouses. Therefore, even if a server is running Version 2 software, its normal behavior is to create Version 1 directories.

If you would like the ability to replicate directories at servers running either Version 1 or Version 2 of the software, accept the default directory version of 1 when you configure a clearinghouse.

Using Version 2 directories results in a smoother upgrade to the next higher version of DECdns when it becomes available. Version 2 directories also improve performance on access checking. However, before you specify a directory version of 2 when configuring a clearinghouse, make sure you never want or need to replicate directories created at this clearinghouse into a Version 1 clearinghouse.

Note

If you have a DECdns Version 2 server clearinghouse (for example, `.eng.host_ch`) that stores more than 200 directories and a DNS Version 1 server that replicates a directory containing the DECdns Version 2 server's clearinghouse object (for example, a DNS Version 1 server replicating directory `.eng`), then the DNS Version 1 server might have insufficient resources to handle the directory's skulk. To prevent this problem, see Section 12.3.2.

F.2. Double ACEs on Directories Replicated at Mixed-Version Servers

Version 1 and Version 2 use different formats for specifying principals in access control entries (ACEs). If you plan to replicate a directory at both Version 1 and Version 2 servers, you must create both Version 1- and Version 2-style ACEs for the directory and its contents. If you do not, you can get unexpected access violations on attempts to replicate, skulk, or otherwise manage the directory and its contents.

In a Version 1 ACE, you specify a principal as `nodename::username`, where *nodename* is the 6-character-maximum DECnet Phase IV-style node name. In a Version 2 ACE, you specify a principal as `nodename.username`, where *nodename* is the DECdns full name of the node. See Chapter 5 for details on creating ACEs.

F.3. Command Interfaces Differ

The Version 1 and Version 2 command interfaces are different. The Version 1 interface, DNS `§CONTROL`, has commands that are similar to the DECnet Phase IV Network Control Program (NCP). The Version 2 DECdns Control Program (DNSCP) has commands that are styled after the DECnet Phase V interface, Network Control Language (NCL).

It is possible to use either the Version 1 or Version 2 control program interface to manage a mixed-version environment, with a few exceptions:

- The Version 2 interface offers more capabilities than the Version 1 interface, including commands that allow you to merge and append portions of a namespace.
- When you use the Version 2 command `set directory to new epoch`, you cannot specify a clearinghouse at a Version 1 server node as the location of the master replica. You must use the Version 1 `rebuild directory` command to establish the master replica in a clearinghouse at a Version 1 server.
- You cannot use the Version 2 interface to manage the following entities on remote systems running Version 1:
 - `dns clerk`
 - `dns clerk known namespace`
 - `dns clerk manual nameserver`
 - `dns clerk remote clearinghouse`
 - `dns server`
 - `dns server clearinghouse`

F.4. Clerks on Nodes with Extended Addresses

DECdns clerks on nodes with extended addresses (without DECnet Phase IV-compatible addresses) can communicate only with DECdns Version 2 servers. They cannot communicate with DNS Version 1 servers, because these servers are DECnet Phase IV nodes. The DECdns clerk node needs a DECnet Phase IV-compatible address to communicate with DNS Version 1 servers or any DECnet Phase IV node.

F.5. Version 2 Clerks Connecting to Version 1 Servers Across a WAN

The Version 2 `dnsconfigure` utility lets a clerk contact a server across a wide area network (WAN) link to obtain the information it needs to communicate with that server. For a Version 2 clerk to obtain the required information from a Version 1 server, the account running `dnsconfigure` on the clerk system must have read access to the `SYS$LIBRARY:DNS$NS_DEF_FILE.DAT` file on the server system.

F.6. Version 1 Clerks Contacting a Version 2 Server's Namespace

DNS Version 1 clerks use a file called `DNS$DEFAULT_FILE.DAT`, which contains data necessary for the clerk to contact at least one server in every namespace with which it needs to communicate. To inform a Version 1 clerk of a namespace in which a DECdns Version 2 server exists, you must sometimes manually create the information for this file and copy it to the clerk system. The manual procedure is necessary in either of the following cases:

- The clerk is on a system running OpenVMS Version 5.4-1 or higher and the server you want it to learn about exists across a WAN.
- The clerk is on a system running a version of OpenVMS lower than 5.4-1; in this case, you must explicitly inform the clerk about the server even when the server exists on the clerk's own local area network (LAN).

To obtain the data needed by the Version 1 clerk, follow this procedure:

1. On the DNS Version 1 clerk system, run the following command from the system prompt to stop the clerk process:

```
$ @sys$manager:dns$clerk_stop.com
```

2. After you stop the clerk, enter the following command:

```
$ @sys$manager:dns$change_def_file.com
```

The following prompt appears:

```
Name of DNS server node?
```

3. At the prompt, enter either the Phase-IV node name or the decimal network address of the Version 2 server node you want to contact and press Return. After you enter this information, the command procedure copies the contents of the `DNS$NS_DEF_FILE.DAT` on the Version 2 server in to the `SYS$SYSTEM:DNS$DEFAULT_FILE.DAT` file on the Version 1 clerk node.
4. Restart the Version 1 clerk by entering the following command:

```
$ @sys$manager:dns$clerk_startup.com
```

Appendix G. Sample Command Files

This appendix includes samples of useful command files. A command file helps ensure that all necessary information has been obtained and entered. If you make a mistake, you need only edit the file and run it again to continue the process. You can save the command file for future use.

G.1. Deleting Server Files

The following two command file examples include commands that delete files left behind after deleting a server, as explained in Section 6.7.2. You can use a command file similar to these to prepare for reconfiguring a server with a new namespace. The command file in this example is designed for use on a DECdns Version 2 server that is not replicated on any other DECdns Version 2 or DNS Version 1 servers.

Note

You can use this command file on a server that is a member of an existing namespace used by multiple servers (either a Version 2.0 or a mixed version namespace). If this is the case, you need to take additional steps on the remaining DECdns server nodes in the namespace to remove pointers to the DECdns Version 2.0 server replica that is being deleted. Also, if the Version 2.0 DECdns server being deleted is in a multi-server namespace, and it contains the only copy of a particular directory, that directory must be copied and set up as a master replica for another server prior to using this procedure. Otherwise, this directory will be lost. Use the DECdns Control Program `create replica` command to create a copy of the directory (that is, create a replica), as explained in Section 7.2. Use the `set directory to new epoch` command to set up the new replica as a master replica on another server, as explained in Section 9.2.

G.1.1. Command File

Example G.1 is a command file for deleting files leftover from a deleted DECdns server.

Example G.1. Command File for Deleting Files Leftover from a Deleted OpenVMS DECdns Server

```
$!  
$! WARNING: This command file deletes DECdns files and automatically  
$! reboots your system. If you are not sure about doing this, do not  
$! use the file.  
$!  
$! This sample command procedure has been tested using DECnet/OSI for  
$! OpenVMS VAX V6.2. However, VSI cannot guarantee its effectiveness  
$! because of the possibility of error in transmitting or implementing it.  
  
$! It is meant for use as a template for writing your own command  
$! procedure and may require modification for use on your system.  
$!  
$! This command file is designed to eliminate an existing DECdns  
$! Version 2.0 server installation on a DECnet Phase V installation.  
$! Ignore any errors in command execution.  
$!  
$ set noverify  
$ set noon  
$ NCL :==$NCL
```

```

$!
$! stop dns server
$!
$ ncl disable dns server
$ ncl delete dns server
$!
$! Delete clearinghouse files
$!
$ del sys$specific:[dns$server]*.tlog*;*/nolog
$ del sys$specific:[dns$server]*.check*;*/nolog
$ del sys$specific:[dns$server]*.version;*/nolog
$ del sys$sysdevice:[dns$server]*.tlog*;*/nolog
$ del sys$sysdevice:[dns$server]*.check*;*/nolog
$ del sys$sysdevice:[dns$server]*.version;*/nolog
$!
$! Delete other server files
$!
$ del sys$manager:dns_files.txt;*/nolog
$ del sys$library:dns$ns_def_file.dat;*/nolog
$!
$! Stop dns clerk
$!
$ @sys$startup:dns$clerk_stop
$!
$! Delete other clerk cache files
$!
$ del sys$system:dns$cache.*;*/nolog
$!
$! Delete default namespace file for clerk
$!
$ del sys$system:dns$default_file.dat;* /nolog
$ del sys$startup:net$dns_clerk_startup.ncl;*/nolog
$!
$! Create a new net$dns_clerk_startup.ncl with no default namespace
$!
$ open/write test sys$sysroot:[sysmgr]net$dns_clerk_startup.ncl
$ write test "create dns clerk"
$ write test "enable dns clerk"
$ close test
$!
$! System must now be rebooted because clerk cache is mapped in memory
$!
$ @sys$system:shutdown 0 reboot no yes later yes none
$ exit

```

G.2. Replicating A Server's Directories Into a New Clearinghouse

Example G.2 is a command file for use with OpenVMS systems that replicates for read-only all the directories of an existing server (.dna_node.shanti) into the newly created clearinghouse .dna_node.meta. The file was designed to execute on the system containing the newly created clearinghouse. This command file does not use DECdns groups. If a significant number of principals share equal access rights, you could use DECdns groups to facilitate adding or removing principals. For more information on the use of groups, see Chapter 5.

The command file is divided into several sections:

Section 1 – Increase the DECdns Clerk Timeout Value for Replication of Large Directories

This timeout value specifies how long the clerk waits for a response to a request. If you are replicating a large number of directories, or the replicas are distributed over a wide area, increase the timeout value. For more information, see Section 6.5.

Section 2 – Expand ACEs on Directories

This step adds the proper access control entries on all the directories in the namespace.

Section 3 – Expand ACEs on Existing Clearinghouse

This step adds access control entries on the existing clearinghouse and the clearinghouse object. Remember that this command file assumes the existing server and clearinghouse were the first in the namespace and the server being configured is only the second one.

Section 4 – Expand ACEs on the New Clearinghouse

This step adds access control entries for the new (second) clearinghouse.

Section 5 – Create Additional Directory Replicas

This step includes commands that create replicas for the new clearinghouse. They are replicas of all the directories in the original clearinghouse.

Section 6 – Rebuild all Directories with Master and Read-Only Clearinghouses

The commands in this section rebuild the directories listed in the preceding section so that the existing (first) clearinghouse contains master replicas and the new (second) clearinghouse contains read-only replicas. In effect, this command file builds a backup clearinghouse for the first clearinghouse. You can customize this file to distribute read-only and master replicas in any way suitable to you.

Section 7 – Set All Directories to Skulk

This step causes all directories to skulk immediately.

Example G.2. Sample OpenVMS Command File for Replicating Directories onto the New Clearinghouse

```

$!
$! Introduction
$!
$! This template command file can be used to perform the majority of
$! dns$control commands necessary to replicate directories into a
$! second read-only DECdns Version 2.0 clearinghouse. You can name
$! the file create_replicas.com and modify it to conform to a
$! specific namespace design. This particular file must be executed from
$! the SYSTEM account on the first clearinghouse node. The example
  namespace
$! for this example file consists of the following:
$!
$! Namespace Nickname:           watts_ns:
$! First Clearinghouse Node:     watts_ns:.dna_node.shanti
$! First Clearinghouse Name:     .shanti_ch
$! Second Clearinghouse Node:    watts_ns:.dna_node.meta
$! Second Clearinghouse Name:    .meta_ch
$! Directories in the Namespace: . (root)

```

```
$! .dna_node
$! .dna_nodesynonym
$! .DTSS_GlobalTimeServers
$! .dna_backtranslation
$! .dna_backtranslation.%X49
$! .dna_backtranslation.%X49.%X0028

$! .dna_backtranslation.%X49.%X0037

$!
$ set noon
$ set verify
$ ncl      ::= $ncl
$ dnscp   ::= $dns$control
$! Section 1: Increase DECdns Clerk Timeout Value for Replication of Large
  Directories
$!
$ ncl
set dns clerk clerk timeout +0-00:10:00.000I0.000
exit
$!

$! Section 2: Expand ACEs on Directories
$!
$! This step adds proper ACEs on all the existing directories in
$! the namespace.
$!
$ dnscp
!
! Add ACEs to all directories for system account from node where
! the second clearinghouse clearinghouse exists
!
add dir .          access .dna_node.meta.system for r,w,d,t,c
add dir .          default access .dna_node.meta.system for r,w,d,t,c
add dir .*         access .dna_node.meta.system for r,w,d,t,c
add dir .*         default access .dna_node.meta.system for r,w,d,t,c
add dir .*...     access .dna_node.meta.system for r,w,d,t,c
add dir .*...     default access .dna_node.meta.system for r,w,d,t,c
!
! Add ACE's to all directories for dns$server account from node where
! the second clearinghouse exists
!
add dir .          access .dna_node.meta.dns$server for r,w,d,t,c
add dir .          default access .dna_node.meta.dns$server for r,w,d,t,c
add dir .*         access .dna_node.meta.dns$server for r,w,d,t,c
add dir .*         default access .dna_node.meta.dns$server for r,w,d,t,c
add dir .*...     access .dna_node.meta.dns$server for r,w,d,t,c
add dir .*...     default access .dna_node.meta.dns$server for r,w,d,t,c
!
! Add ACE's to all directories for the second clearinghouse named .meta_ch
!
add dir .          access .meta_ch for r,w,d,t,c
add dir .          default access .meta_ch for r,w,d,t,c
add dir .*         access .meta_ch for r,w,d,t,c
add dir .*         default access .meta_ch for r,w,d,t,c
add dir .*...     access .meta_ch for r,w,d,t,c
```

```
add dir *.*... default access .meta_ch for r,w,d,t,c
exit
$!

$! Section 3: Expand ACEs on Existing Clearinghouse
$!
$! A clearinghouse is a database containing a collection of directory
$! replicas at a particular server. Certain accounts must have access
$! to each clearinghouse for management and skulking operations to
  complete.
$! The following commands add ACEs on both the clearinghouse and the
$! clearinghouse object.
$!
$ dnscp
!
! Add ACEs for Existing Server Node Name and Accounts
!
add clear .shanti_ch access .dna_node.shanti.system          for r,w,d,t,c
add clear .shanti_ch access .dna_node.shanti.dns$server      for r,w,d,t,c
add clear .shanti_ch access .dna_node.shanti.DNA$SessCtrl    for r,w,d,t,c
add obj   .shanti_ch access .dna_node.shanti.system          for r,w,d,t,c
add obj   .shanti_ch access .dna_node.shanti.dns$server      for r,w,d,t,c
add obj   .shanti_ch access .dna_node.shanti.DNA$SessCtrl    for r,w,d,t,c

!
! Add ACEs for New Server Node Name and Accounts
!
add clear .shanti_ch access .dna_node.meta.system            for r,w,d,t,c
add clear .shanti_ch access .dna_node.meta.dns$server        for r,w,d,t,c
add clear .shanti_ch access .dna_node.meta.DNA$SessCtrl      for r,w,d,t,c
add obj   .shanti_ch access .dna_node.meta.system            for r,w,d,t,c
add obj   .shanti_ch access .dna_node.meta.dns$server        for r,w,d,t,c
add obj   .shanti_ch access .dna_node.meta.DNA$SessCtrl      for r,w,d,t,c

!
! Add ACEs for World Read and Test
!
add clear .shanti_ch access *.*... for r,t
add obj   .shanti_ch access *.*... for r,t
exit
$!

$! Section 4: Expand ACEs on the New Clearinghouse
$!
$ dnscp
!
```

```
! Add ACEs for Existing (first) Server Node Name and Accounts
!
add clear .meta_ch access .dna_node.shanti.system          for r,w,d,t,c
add clear .meta_ch access .dna_node.shanti.dns$server     for r,w,d,t,c
add clear .meta_ch access .dna_node.shanti.DNA$SessCtrl   for r,w,d,t,c
add obj   .meta_ch access .dna_node.shanti.system          for r,w,d,t,c
add obj   .meta_ch access .dna_node.shanti.dns$server     for r,w,d,t,c
add obj   .meta_ch access .dna_node.shanti.DNA$SessCtrl   for r,w,d,t,c

!
! Add ACEs for New (Second) Server Node Name and Accounts
!
add clear .meta_ch access .dna_node.meta.system           for r,w,d,t,c
add clear .meta_ch access .dna_node.meta.dns$server      for r,w,d,t,c
add clear .meta_ch access .dna_node.meta.DNA$SessCtrl    for r,w,d,t,c
add obj   .meta_ch access .dna_node.meta.system           for r,w,d,t,c
add obj   .meta_ch access .dna_node.meta.dns$server      for r,w,d,t,c
add obj   .meta_ch access .dna_node.meta.DNA$SessCtrl    for r,w,d,t,c
!
! Add ACEs for World Read and Test
!
add clear .meta_ch access .*... for r,t
add obj   .meta_ch access .*... for r,t
exit
$!

$! Section 5: Create Additional Directory Replicas
$!
$! The following commands create replicas of all the desired
$! directories for the second clearinghouse called .meta_ch. Use the
$! results of the tree-walk performed in Step 1 to determine which
$! directories need replication. The root [.] directory need not be
$! replicated because that operation was completed in a previous step

$! by the dns$configure.com utility.
$!
$! Note: DECnet PhaseIV areas 40 and 55 (hexadecimal %x0028 and %x0037)

$!     are the only .dna_backtranslation.%x49.* directories shown.
$!     If the namespace includes additional directories and you
$!     want them replicated, include them.
$!
$ dnscp
create replica .dna_node clearinghouse .meta_ch
create replica .dna_nodesynonym clearinghouse .meta_ch
create replica .DTSS_GlobalTimeServers clearinghouse .meta_ch
create replica .dna_backtranslation clearinghouse .meta_ch
create replica .dna_backtranslation.%x49 clearinghouse .meta_ch
create replica .dna_backtranslation.%x49.%x0028 clearinghouse .meta_ch

create replica .dna_backtranslation.%x49.%x0037 clearinghouse .meta_ch

exit
```



```
$!  
  
$! Section 6: Rebuild all Directories with Master and Read-Only  
$!           Clearinghouses.  
$!  
$! The following commands rebuild the same directories listed above  
$! to include both clearinghouses. The root [.] directory is included.  
  
$!  
$dnscp set dir . to new epoch -  
master .shanti_ch, read-only .meta_ch  
$!  
$dnscp set dir .dna_node to new epoch -  
master .shanti_ch, read-only .meta_ch  
$!  
$dnscp set dir .dna_nodesynonym to new epoch -  
master .shanti_ch, read-only .meta_ch  
$!  
$dnscp set dir .DTSS_GlobalTimeServers to new epoch -  
master .shanti_ch, read-only .meta_ch  
$!  
$dnscp set dir .dna_backtranslation to new epoch -  
master .shanti_ch, read-only .meta_ch  
$!  
$dnscp set dir .dna_backtranslation.%X49 to new epoch -  
master .shanti_ch, read-only .meta_ch  
$!  
$dnscp set dir .dna_backtranslation.%X49.%X0028 to new epoch -  
master .shanti_ch, read-only .meta_ch  
$!  
$dnscp set dir .dna_backtranslation.%X49.%X0037 to new epoch -  
master .shanti_ch, read-only .meta_ch  
$!  
  
$! Section 7: Set All Directories to Skulk  
$!  
$! The following commands set all directories to skulk immediately.  
$! Skulking is the process where read-only directories are updated from  
  
$! the master copy. DECdns performs skulking at regular intervals  
$! after this procedure is complete.  
$!  
$ dnscp  
set dir . to skulk  
set dir .dna_node to skulk  
set dir .dna_nodesynonym to skulk  
set dir .DTSS_GlobalTimeServers to skulk  
set dir .dna_backtranslation to skulk  
set dir .dna_backtranslation.%X49 to skulk  
set dir .dna_backtranslation.%X49.%X0028 to skulk  
set dir .dna_backtranslation.%X49.%X0037 to skulk  
exit  
$! Replication of All Directories into the Second Clearinghouse  
$! is now Complete.  
$ set noverify  
$ exit
```

Appendix H. The DECdns Browser Utility

DECdns provides the DECdns Browser utility (for DECwindows and Motif users only) to display namespace information. This utility is not supported by VSI.

The DECdns Browser is a tool for viewing the namespace. To use it, you need DECwindows or Motif software. The DECdns Browser can display an overall directory structure as well as the contents of directories, enabling you to monitor growth and change in the namespace. You can customize the DECdns Browser utility to display only certain kinds of object entries, such as those representing nodes, Remote System Manager (RSM) servers, or DECdfs access points. You also can quickly change the browser display from one directory to another, and even to a directory in another namespace.

This appendix gives an overview of the DECdns Browser utility. It assumes you are familiar with basic DECwindows terms and concepts. For a detailed tutorial, see the *DECwindows User's Guide*. Detailed online help is available from the browser window's Help pull-down menu.

H.1. Starting the Browser

To start the DECdns Browser, enter the following DCL command:

```
$ run sys$system:dnsbrowser
```

To end a browser session, choose Quit from the File menu.











H.2. Expanding and Collapsing Directories

When you start the DECdns Browser, the only item in the display is the root directory of the system's default namespace. Double click on the root directory to **expand** (open) it. To **collapse** (close) an expanded directory, double click on it.

When you expand a directory, you see the soft links and object entries to which you have read access. You also see all child directories, but you can expand only those child directories to which you have read access.

Directories, object entries, and soft links all have icons associated with them in the browser. Most object entries have unique icons based on their class; the class indicates the type of resource that the entry represents (nodes, DFS access points, and so on). When the browser does not recognize the class of an entry, it displays a generic icon. Figure H.1 shows the browser icons and what they represent.

Figure H.1. DECdns Browser Icons and Their Meaning

Icon	Entry Type	Icon	Entry Type
	Directory		RSM client
	Object entry (generic)		RSM server
	Soft link		VAX Notes conference
	Cleaninghouse object entry		DFS access point
	Node		Group

ZK-8786A-GE

By double clicking on single directories, you can continue expanding a particular directory path one level at a time. Other methods are available to expand all directories at once or to expand selected groups of directories.

Expanding or collapsing a group of directories involves selecting them and double clicking. Note that because double clicking has a toggle effect, you can expand or collapse groups of directories only one level at a time. If you double click multiple directory levels at a time, the result may be the opposite of what you expect.

To expand or collapse selected directories, click on the first directory you want to select, then continue selecting directories by shift clicking on them. When selecting the last directory, give it a double click instead of a single click, while still pressing the Shift key (this selects the last directory and expands or collapses all of the directories you have selected).

To expand all directories on all levels at once, choose the Expand All option from the File menu. Likewise, choose Collapse All from the File menu to close an expanded namespace.

Note

Use the Expand All option carefully if you have a large namespace. The larger a namespace, the longer it takes to display its entire contents.

H.3. Namespace Display Formats

The browser has two formats for displaying the namespace: outline format and tree format. The default is outline format, as shown in Figure H.2.

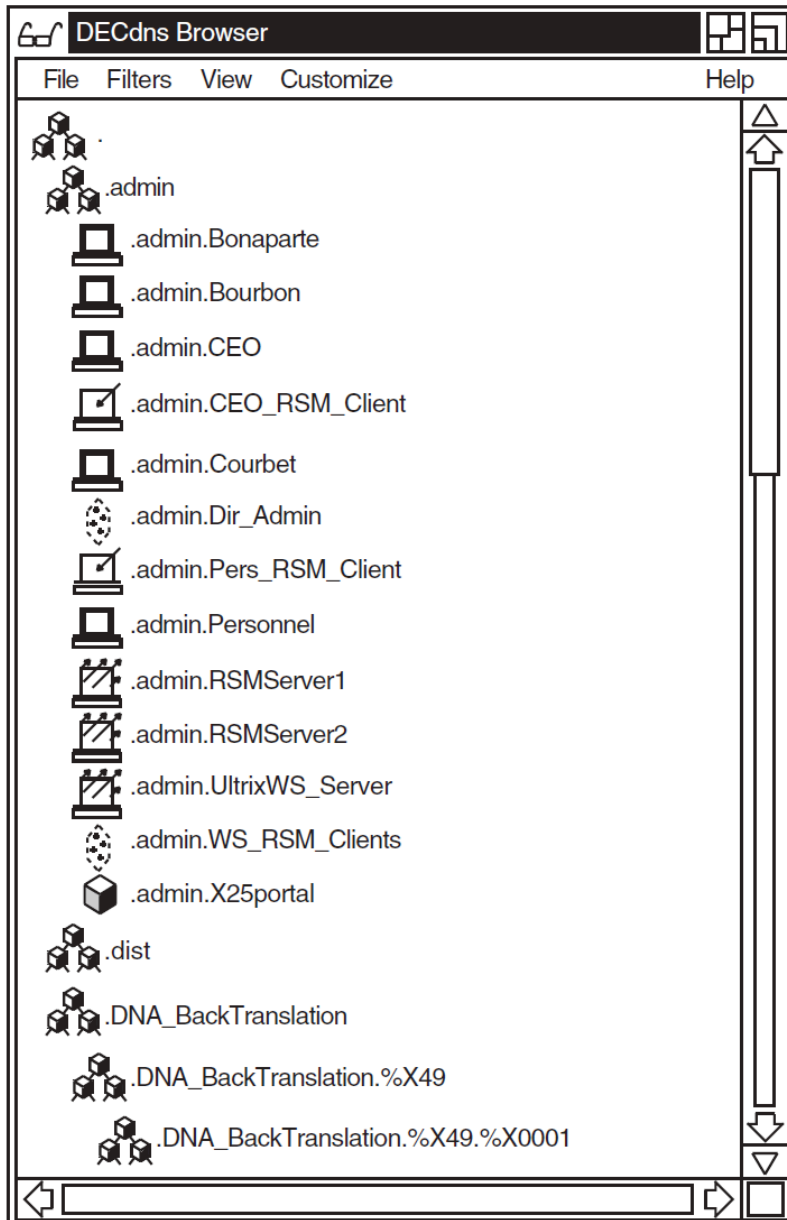
Figure H.2. Namespace in Outline Format

ZK-8787A-GE

Figure H.3 shows the same namespace in tree format. To toggle between the two formats, choose Display Tree or Display Outline from the View menu.

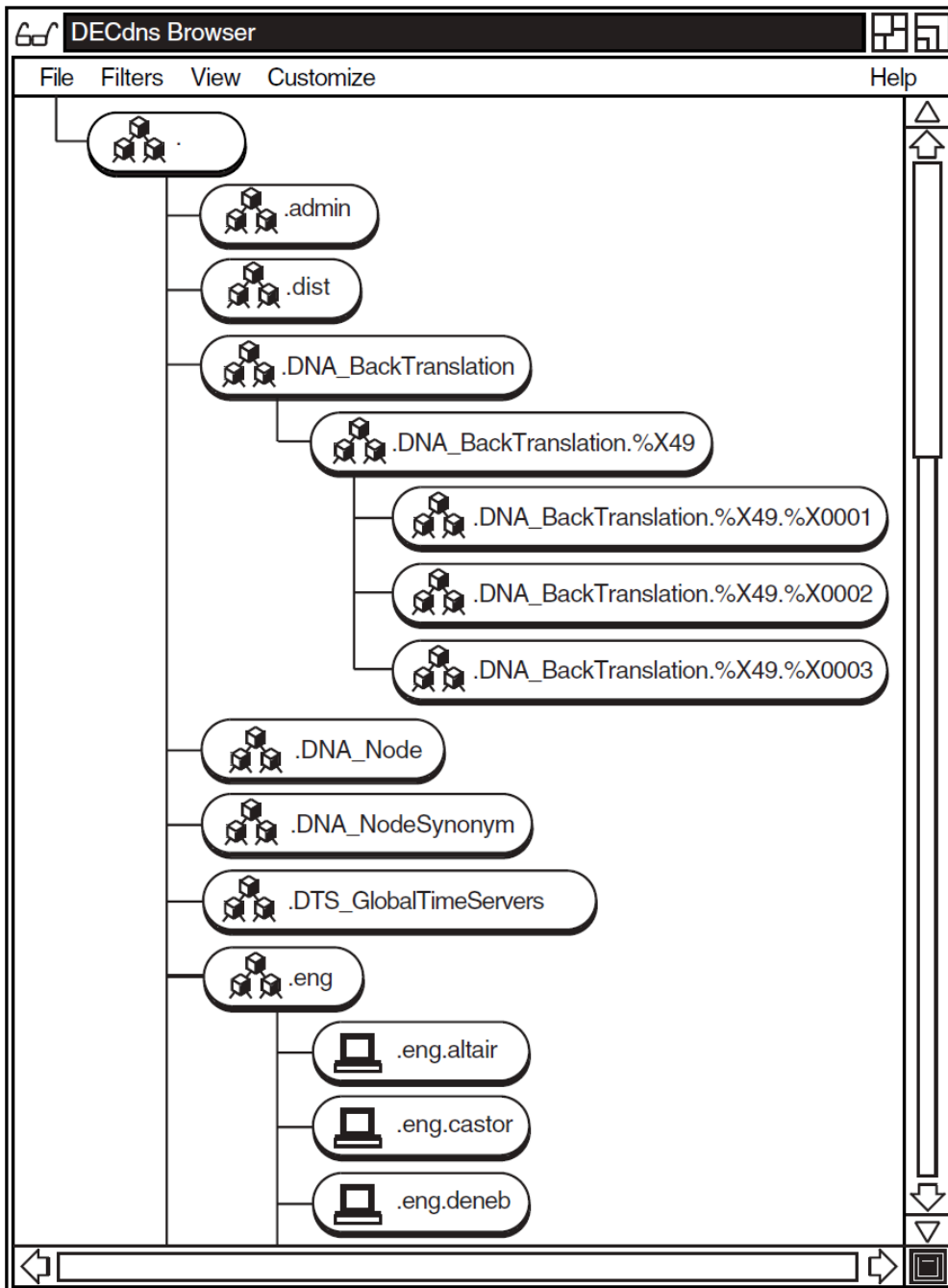
Figure H.3. Namespace in Tree Format

ZK-8788A-GE

H.4. Using a Virtual Root

To customize your view of the namespace, you can specify a **virtual root**—a directory other than the root at which you want the browser to start displaying the namespace.

The virtual root is a convenient way to focus immediately on a particular directory of interest instead of expanding directories level by level. It also enables you to quickly change the browser display from one directory to another, and even to a directory in another namespace.

Another use of the virtual root is in a secure namespace that does not allow read access to all directories for all users. For example, the browser normally displays the root directory (.) when it starts. However, if you do not have read access to the root directory, you cannot expand it. To display and expand a directory to which you do have access, you can specify its name as the virtual root.

To set a virtual root, choose Virtual Root from the Customize menu. A Virtual Root selection box appears. At the Selection prompt, enter the full name of the directory (including the namespace nickname, if necessary) that you want to specify as the virtual root.

Once you have entered one or more virtual root names, subsequent displays of the Virtual Root selection box show an alphabetized list of the most recently specified names. The list always includes the root directory (.) of the default namespace. Double click on a directory name in the list to cause it to become the new virtual root.

You can save the list of virtual roots from one browser session to another by choosing Save Virtual Root Settings from the Customize menu.

H.5. Filtering the Namespace Display

You can use the Filters menu to selectively display only objects of a specific class. For example, if you are interested in seeing only node object entries, choose the class `DNA$Node` from the Filters menu.

Setting a filter does not affect the current display, but when you next expand a directory, you see only object entries whose class matches the filter. Note that soft links and child directories still appear; they are not object entries and the browser filters only object entries.

You can filter only one object class at a time. To change the filter, choose a new class from the Filter menu. To reset the filter so you can view all entries, choose the asterisk (*) from the Filters menu.

H.6. Navigating the Namespace

Once you begin expanding the namespace, it may exceed the boundaries of the browser window, even if you enlarge the window. You can use the horizontal and vertical scroll bars and stepping arrows to scroll through the namespace.

H.6.1. Outline Navigation Aids

If the namespace display is in outline format, dragging the slider up and down the vertical scroll bar produces an **index window**, as shown in Figure H.4. The index window shows the name where the slider is currently positioned in the namespace. When the index window contains the name you want to view, release MB1 (mouse button 1) to position that name at the top of the browser window.

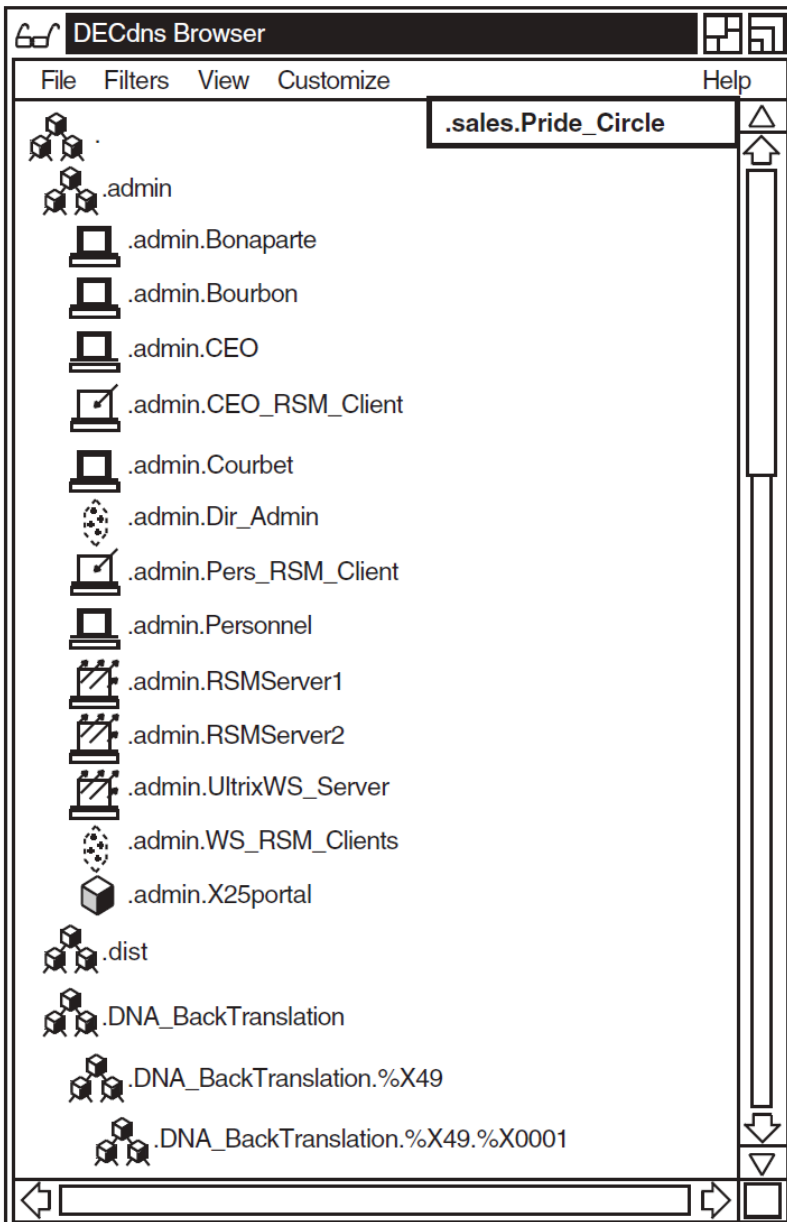
Figure H.4. Namespace with Index Window

ZK-8789A-GE

In namespaces that are larger than the length of the browser window, scrolling through directory levels may produce a reference line toward the top of the window. The line orients you by showing the full directory path from the current name to the root or virtual root. It also indicates that you have scrolled past other parts of the namespace that are no longer displayed. Figure H.5 illustrates how a reference line is produced. On the left is a display before it has been scrolled. On the right is the same display after the user has scrolled to the middle of the `.eng` directory. The root and `.eng` directories above the reference line indicate the hierarchy of which the `.eng.RSM_Server` entry is a part.

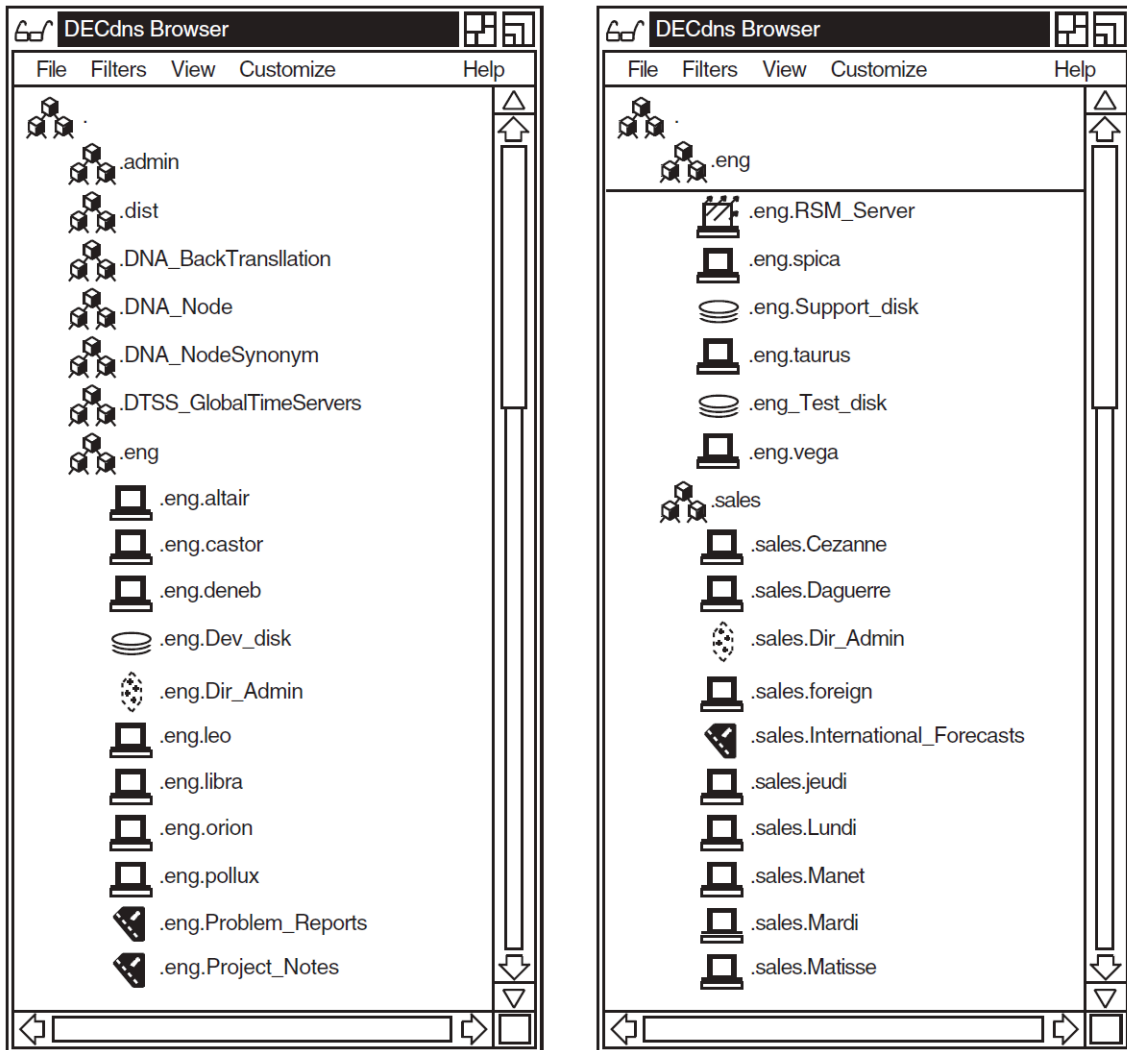
Figure H.5. Display with Reference Line

ZK-8790A-GE

H.6.2. Tree Navigation Aids

If the namespace display is in tree format, dragging the slider on a scroll bar produces a **navigation window**. Figure H.6 shows the navigation window within the browser window.

The navigation window contains a reduced image of the currently expanded part of the namespace. The box within the navigation window indicates the portion of the namespace where the slider is positioned; releasing MB1 displays that portion of the namespace in the browser window and closes the navigation window.

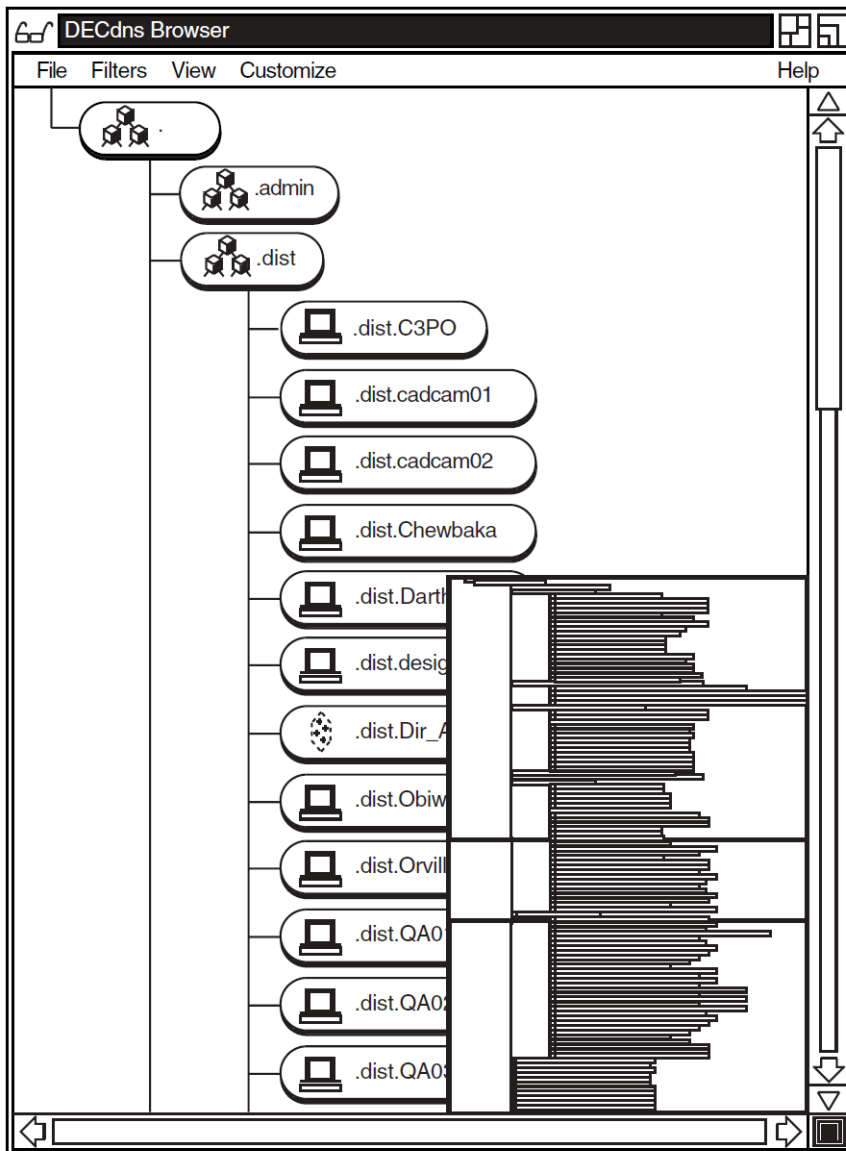
Figure H.6. Display with Navigation Window

ZK-8791A-GE

To make the navigation window a separate, permanent window, click on the button at the bottom right corner of the browser window. Click on the same button to close the navigation window.

To move around in the namespace display, point anywhere in the navigation window and drag the mouse up, down, left, or right to move the box that is inside the navigation window. When you release MB1, the portion of the namespace that is inside the box appears in the browser window.